

Section 16122 PRIMARY POWER CABLES

PART 1 GENERAL:

- **WORK INCLUDED**

The Contractor shall furnish and install all shielded power cable suitable for use on this project.

- **RELATED WORK**

Section 16020: Tests

- **SUBMITTALS**

The Contractor shall submit test and product data in accordance with Section OI 300.

PART 2 PRODUCTS:

Acceptable Manufacturer: Okonite or Kerite meeting these specifications is acceptable.

- **TYPE AND RATING**

The cable shall be certified for normal operation at a conductor temperature of 105 degrees C; in wet and dry locations; in conduit above and below ground; in exposed cable tray runs. Conductors shall also be certified for operation at 1 30°C during emergency conditions and 250°C under short circuit conditions. The cable insulating and jacketing materials shall have a forty year average service life.

All cable shall have the voltage ratings as hereinafter specified with ethylene propylene rubber insulation and suitably sized copper conductors. The cable shall be supplied in the quantities and number of conductors specified and for the functions as listed.

- **SHIELDED POWER CABLE**

Cable Type and Size	Voltage Rating
Copper Conductors Copper Foil Shield	15 kV - 133% Insulation

- **QUALITY ASSURANCE**

Each power cable shall be given the manufacturer's standard production tests to assure that all cables adequately meet the requirements of these specifications. All cable shall conform to the applicable requirements of ICEA Publication S-68-516, UL 1072, Federal Standard 10 CFR 50, and UL Type MV 105 EPR and the latest specifications for extruded insulation. The copper conductors shall conform to ASTM-B8 for annealed copper, Class B stranded, compressed concentric round.

Test data shall be furnished to the Owner. Test data may apply to the cables being furnished under this purchase order, or may be certified results of tests previously made on identical cables.

Materials used in the manufacture of the cable covered by these specifications shall be of the kind, composition and physical properties best adapted to their various purposes and conform to the standards of AEIC, ANSI, ASTM, IEEE, ICEA, NEC, NEMA and UL in effect on the date of the bid-opening as to material, workmanship, design and testing. Tolerances and practices in manufacture of finished cable shall conform to the best modern shop practices.

- **SPECIFIC SUBMITTAL REQUIREMENTS**

Materials Test Reports: Where specific materials tests are herein specified or where such tests are required by specific standard governing the manufacture of such materials, six (6) copies of certified test results shall be furnished by the manufacturer to the Contractor who shall submit them to the Owner.

The Contractor shall submit certified copies of the results of all standard production tests and tests performed in accordance with NEMA, and ICEA S-66-524 Standards as required by paragraph above, "Quality Assurance".

Technical Data: Contractor shall submit within 30 calendar days after receipt of Notice of Award values for all technical data regarding the cable being furnished.

- **DESIGN AND CONSTRUCTION**

Conductors: All copper conductors shall be stranded, and fabricated from uncoated, annealed copper wire conforming to ASTM B8. Stranding shall be concentric lay Class B, Standard, #2 cable.

Insulation: Conductors shall be insulated with ethylene propylene flexible thermosetting dielectric compound. The ethylene content of the compound shall not exceed 72% by weight of ethylene nor shall the compound contain any polyethylene. The insulation shall be triple-tandem extruded with the conductor and insulation screens. The extruded screen shall be free stripping. The outer screen/insulated core shall be covered with an uncoated copper tape. It shall be applied helically with 12.5% nominal overlap. The overall jacket shall be polyvinyl chloride.

Semi-Conductor Screens: These shall be Ethylpropylene based.

Identification: All cable shall have a permanent and readily identifiable exterior surface marking at appropriate intervals along its entire length. The method of marking shall be subject to the approval of the Owner. The marking shall contain the following information:

- Manufacturer
- Year of manufacture
- Size and type of conductor
- Rated voltage
- Insulation thickness
- Shield
- Type of jacket

Reels: All cable shall be furnished on reels. Each reel shall have the diameter of the drum large enough to prevent damage to the cable from reeling. The maximum flange diameter of the reel is not to exceed 78 inches. The outer end of the cable shall be securely fastened to the reel head so as to prevent the cable from becoming loose in transit. The inner end of the cable shall project into a slit in the side of the reel or into a housing on the inner side of the drum in such a way as to

DIVISION 16 ELECTRICAL**PROJECT NO.**

make it available, if required, for test. The inner end shall be fastened to prevent it from becoming loose during installation. Each reel shall be plainly marked to indicate the direction in which it should be rolled to prevent loosening of the cable on the reel. The reels shall be lagged. Each length of cable shall be effectively sealed to prevent the entrance of moisture. The seal shall be applied in such a way as to prevent damage to the conductors or cable.

- **DATE OF MANUFACTURE**

All cable utilized in a pull shall have been manufactured during the same production run from the factory. All cable shall be new and shall have been manufactured within 3 months of the date of receipt at the job site. Storage of cable prior to installation shall comply with the recommendations of the manufacturer.

- **GUARANTEE**

The manufacturer of the cable shall furnish medium voltage cable which shall comply with the following warranty:

"The manufacturer shall warrant the cable to free from defects in material and workmanship for the 40 year design life of the cable; provided the cable is employed under the conditions contemplated and covered by the design specifications, and provided further that the cable is installed, spliced, terminated, maintained, and operated in accordance with the manufacturer's recommended procedures, at the time of bid."

In the event that the cable is defective in manufacture, as determined by the manufacturer and the University of Arizona jointly, the manufacturer's only responsibility will be to supply another cable for the defective portion, the new cable to be delivered free of charge to the University of Arizona.

Manufacturer shall not be responsible for any defects or repairs to, or replacement of, adjacent or connected equipment to which the cable may supply electric power or from which it may take electrical power or from which it may take electrical power. Manufacturer will not be responsible for any termination, maintenance, or operation which is not in accordance with the manufacturer's recommended standards and procedures."

PART 3 EXECUTION:

- **INSTALLATION**

Reels shall be rolled only in the direction indicated by the manufacturer and no reel containing cable shall be dropped from a truck or from any other comparable height, under any circumstances. In turning reels, particularly after the lagging has been removed, bars shall be used in such a manner that they will not bear against the cable. Reels shall not be rolled over rocks or other projecting objects which are liable to damage the cable and, when it is necessary to roll unlagged reels over soft ground, plant tracks shall be provided to keep the reel from sinking with possible damage to the cable. Cable shall be carefully handled during installation and shall be unreeled or uncoiled slowly to prevent damage to the insulation or sheath from sudden bending. The ends of any cable used shall be kept sealed from moisture at all times, either for cables that have been pulled and are awaiting connection, or for cables on reels in storage. In no case shall cables be allowed to lie on the floor or any other location where they may be subject to damage. If necessary, temporary supports shall be provided and arranged so as not to interfere with any provisions for permanent supports, or require any cable splicing. When reeling the cable

off of the reels and pulling it into the conduit every effort must be made to protect the cable from damage. The cable shall not be pulled off onto bare ground, asphalt, or concrete. Wherever it is required to pull cable off of the reel for a subpull it shall be necessary for the contractor to provide a surface which will not subject the cable to abrasion during the subpull.

Sharp kinks shall be avoided in any unreeling, uncoiling, and pulling operation, and the cable shall be carefully guided and trained into conduits or other raceways in as direct a manner as possible with a minimum amount of bending. The Contractor shall be responsible for keeping any cable bends to as large a radius as feasible and, where practicable, the minimum radius shall be kept at a value no less than 12 times the outer diameter of the insulation or covering. Where conditions dictate the installation, necessary bends of a small radius will be permitted, subject to the approval of THE UNIVERSITY OF ARIZONA. Any cable pulled in a manner resulting in damage to the shielding shall be removed and replaced at the direction of THE UNIVERSITY OF ARIZONA and at the Contractor's expense. Following the installation of the cable and until such time as the splice or stress cone is made the cable shall be resealed to prevent absorption of moisture into the insulation of the cable.

Before any cable is pulled in any conduit, such conduit shall have been tested for and cleared of, any obstruction in accordance with the requirements of Section 16115. The conduit termination shall be provided with a bushing or other suitable protector to guard against damage to the insulation or outside covering. Cable may be pulled by woven basket wire grips or by attachment of the pulling device directly to the conductor. Pulling tension shall not exceed the manufacturer's recommended limits. Soapstone, or other non-hardening pulling lubricant, approved by THE UNIVERSITY OF ARIZONA electrical engineer for the type of insulation involved, shall be used to help facilitate pulling requirements. All cable installed shall be arranged, and tied where necessary, in the opinion of THE UNIVERSITY OF ARIZONA, in a neat and orderly manner. Cable shall enter and leave in neat packs and shall be arranged in such a way as not to block openings or future use. The cables shall be supported clear of sharp edges or any structural framework. Cables shall be kept clear of any obstruction while placing. Cable installation procedures shall be reviewed by the U of A electrical engineer and shall be subject to the approval of the Owner.

Splices will not be permitted except where indicated on the drawings or where specifically approved by the engineer prior to start of work for high voltage cable. The Contractor shall furnish all materials and perform all work required for the complete termination or splicing of any wire, or cable including any stress cones that may be required. Terminations, splices and stress cones for high voltage cables and conductors shall be completed in accordance with manufacturer's recommendations or as directed by THE UNIVERSITY OF ARIZONA.

All high voltage cable splicing and dressing work shall be performed by men and crews thoroughly experienced (minimum five years) in such work, and each such cable splicer shall be approved by THE UNIVERSITY OF ARIZONA before splicing has begun. High voltage cable shall be given a high potential test per the requirements of section 16950 before final termination. Where desirable, the final termination taping shall be extended over the terminal connector onto the bus or bushing of the equipment to which the conductor is attached. Final taping shall generally be applied from bottom to top to provide the best possible shield and, in wet or damp locations, terminal taping shall be painted with insulating varnish. The Contractor may use premolded slip on type splices, taps and stress-cones. These premolded devices shall be made of ethylene propylene terpolymers. All cable splices shall be approved for use by the cable manufacturer on the specific cables.

DIVISION 16 ELECTRICAL**PROJECT NO.**

Where T connections are approved by the University of Arizona Engineer, utilize bushars with load break elbow terminals and bushings. Use deadfront devices when they are available.

PART 4 PHASING AND IDENTIFICATION:

The contractor shall verify the existing phasing on all equipment being reconnected to a new service prior to removing the equipment and shall reconnect the equipment back to match original phasing following the completion of the installation of the new service.

End of Appendix Section 16122

Section 16310 - PRIMARY SWITCH STATION

PART 1 GENERAL

1.01 Description of Work

- A. The pad-mounted gear shall be in accordance with the one-line diagram, and shall conform to the following specification. This gear shall be type PMH-11 or PMH-9 as determined by consultation with the University of Arizona Electrical Engineer. It shall be as manufactured by S&C Corporation or prior approved equal.
- B. The pad-mounted gear shall consist of a single self-supporting enclosure, containing interrupter switches and power fuses with the necessary accessory components, all completely factory-assembled and operationally checked.
- C. NOTE: It is the intent of the University to use equipment rated for 13.8 KV ungrounded systems on 4160 volt at this time to allow for conversion to 13.8 KV ungrounded systems in the future.

1.02 Ratings

- A. The ratings for the integrated pad-mounted gear shall be as designated below:

KV, Nominal 14.4	
KV, Maximum Design	17.0
KV, BIL	95
Main Bus Continuous, Amperes	600
Three Pole Interrupter Switches	
Continuous, Amperes (Source/Feeder)	600/600
Live Switching, Amperes (Source/Feeder)	600/600
Two-Time Duty-Cycle Fault-Closing	
Capability, Amperes Rms Asymmetrical	22,400
Fuses with Integral Load Interrupter	
Maximum, Amperes	200
Live Switching, Amperes	200
Two-Timing Duty-Cycle Fault-Closing	
Capability, Amperes Rms Asymmetrical	13,000
Short-Circuit Ratings	
Amperes, Rms Symmetrical at	12,500
Mva Three-Phase Symmetrical at	
Rated Nominal Voltage	310

- B. The momentary and two time duty cycle fault closing ratings of switches and bus, interrupting ratings of fuses, and one-time duty-cycle fault-closing capabilities of the fuses with integral load interrupters shall equal or exceed the short-circuit ratings of the pad-mounted gear.

1.03 Certification of Ratings

- A. The manufacturer shall be completely and solely responsible for the performance of the basic switch and fuse components as well as the complete integrated pad-mounted gear assembly as rated.
- B. The manufacturer shall furnish with the bid certification of ratings of the basic switch and fuse components and the integrated pad-mounted gear assembly consisting of the switch and fuse components in combination with the enclosure.

1.04 Compliance with Standard and Codes

- A. The pad-mounted gear shall conform to or exceed the applicable requirements of the following standards and codes:
 - 1. Applicable safety and health standards promulgated pursuant to Federal Occupational Safety and Health Act of 1970 which are in effect 30 days prior to the date of quotation or bid.
 - 2. Article 710-21(e) Circuit Interrupting Devices (Load Interrupters) in the 1984 National Electrical Code, which specifies that the interrupter switches in combination with power fuses shall safely withstand the effects of closing, carrying, and interrupting all possible currents up to the assigned maximum short-circuit rating.
 - 3. All portions of ANSI, IEEE, and NEMA standards applicable to the basic switch and fuse components.

1.05 Enclosure Design

- A. To ensure a completely coordinated design, the pad-mounted gear assembly shall be constructed in accordance with the minimum construction specifications of the fuse and/or switch manufacturer to provide adequate electrical clearances and adequate space for fuse handling.
- B. In establishing the requirements for the enclosure design, consideration shall be given to all relevant factors such as controlled access and tamper resistance. Provide padlock and penta head fasteners, in addition to manufacturer's normal controls.

PART II PRODUCTS AND EXECUTION

2.01 Insulators

- A. The interrupter-switch and fuse-mounting insulators shall be of a cycloaliphatic epoxy resin system with characteristics and restrictions as follows:
 - 1. Operating experience of at least 10 years under similar conditions.
 - 2. Ablative action to ensure nontracking properties.
 - 3. Adequate leakage distance established by test per IEC Publication 507, First Edition, 1975.
 - 4. Adequate strength for short-circuit stress established by test.
 - 5. Conformance with applicable ANSI standards.
 - 6. Homogeneity of the cycloaliphatic epoxy resin throughout each insulator to provide maximum resistance to power arcs. Ablation due to high temperatures from power arcs shall continuously expose more material of the same composition and properties so that no change in mechanical or electrical characteristics takes place because of arc-induced ablation. Furthermore, any surface damage to insulators during installation or maintenance of the pad-mounted gear shall expose material of the same composition and properties so that insulators with minor surface damage need not be replaced.

2.02 High-Voltage Bus

- A. Bus and interconnections shall consist of copper bar.
- B. Bus and interconnections shall withstand the stresses associated with short circuits up through the maximum rating of the pad-mounted gear, including proper allowance for transient conditions.
- C. All current carrying parts shall be copper or bronze.

2.03 Ground-Connection Pads

- A. A ground-connection pad shall be provided in each compartment of the padmounted gear.
- B. The ground-connection pad shall be constructed of steel, 3/8" thick for use with 600 ampere main bus which shall be copper clad and welded to the enclosure, and shall have a short-circuit rating equal to that of the integrated assembly.
- C. Ground-connection pads shall be coated with a uniform coating of an oxide inhibitor and sealant prior to shipment.

2.04 Enclosure

- A. The pad-mounted gear enclosure shall be of unitized monocoque (not structural frame-and-bolted-sheet) construction to maximum strength, minimize weight, and inhibit internal corrosion.
- B. The basic material shall be 11-gauge hot-rolled, pickled, and oiled steel sheet.
- C. All structural joints and butt joints shall be welded, and the external seams shall be ground flush and smooth.
 - 1. The gas-shielded short-circuiting transfer welding process shall be employed to eliminate alkaline residues and to minimize distortion and spatter.
 - 2. Any welds made by other than this method shall be ground and sanded (wire brushed if internal) to remove all scale and alkaline residues formed during welding.
- D. To guard against unauthorized or inadvertent entry, enclosure construction shall not utilize any externally accessible hardware.
- E. The base shall consist of continuous 90-degree flanges, turned inward and welded at the corners, for bolting to the concrete pad. The flanges shall be formed from double-thickness folded edges for strength and rigidity, with the sheared edges folded back into the inside of the enclosure to minimize exposure to corrosive attack.
- F. The door openings shall have 90-degree flanges, facing outward, that shall provide strength and rigidity as well as deep overlapping between doors and door openings to guard against water entry.
- G. Roof edges shall be formed to create a mechanical maze with the top flanges of the enclosure which shall allow free-flow ventilation to help keep the enclosure interior dry while discouraging tampering or insertion of foreign objects.
- H. A heavy coat of insulating "no-drip" compound shall be applied to the inside surface of the roof to prevent condensation of moisture thereon.
- I. Insulating interphase and end barriers of fiberglass-reinforced polyester shall be provided for each interrupter switch and each set of power fuses where required to achieve BIL ratings. Additional insulating barriers of the same material shall separate the front compartments from the rear compartments and isolate the tie bus (where furnished).
- J. Models containing source switches rated 600 amperes continuous shall have full-length steel barriers separating adjoining compartments.
- K. Lifting tabs shall be removable. Sockets for the lifting tab bolts shall be blind-tapped. A resilient material shall be placed between the lifting tabs and the enclosure to prevent the tabs from scratching the enclosure finish. To help retard corrosion, this material shall be closed-cell neoprene to prevent moisture from being absorbed and held between the tabs and the enclosure.

- L. Interrupter switches shall be provided with dual-purpose front barriers. These barriers, in their normal hanging positions, shall guard against inadvertent contact with live parts. It shall also be possible to lift these barriers out and insert them into the open gap when the switch is open. A window panel shall be provided to allow viewing of the switch position without removing the barriers. These barriers shall meet the requirements of Section 381 .G of the National Electrical Safety Code (ANSI Standard C2).
- M. Each fuse shall be provided with a dual-purpose front barrier. These barriers, in their normal hanging positions, shall guard against inadvertent contact with live parts. It shall also be possible to lift these barriers out and insert them into the open gaps when the fuses are in the disconnect position. These barriers shall meet the requirements of Section 381.G of the National Electrical Safety Code (ANSI Standard C2).
- N. A (steel-compartmented) base spacer shall be provided to increase the elevation of live parts in the pad-mounted gear above the mounting pad by 24 inches.

2.05 Doors

- A. Doors shall be constructed of 11 gauge hot-rolled, pickled, and oiled steel sheet.
- B. Door-edge flanges shall overlap with door-opening flanges and shall be formed to create a mechanical maze that shall guard against water entry and discourage tampering or insertion of foreign objects, but shall allow free-flow ventilation to help keep the enclosure interior dry.
- C. Doors shall have a minimum of three stainless steel hinges and hinge pins. The hinge pins shall be welded in place to guard against tampering.
- D. In consideration of controlled access and tamper resistance, each door (or set of double doors) shall be equipped with a positive-action three-point latching system.
- E. Each door (or set of double doors) shall be provided with a recessed stainless steel door handle. The door handle shall be padlockable and shall incorporate a hood to protect the padlock shackle from tampering. The handle shall be provided with a recessed penta head bolt for additional security.
- F. Doors providing access to solid-material expulsion-type power fuses shall have provisions to store spare refill units.
- G. Each door shall be provided with a galvanized-steel door holder located above the door opening. These holders shall be hidden from view when the door is closed, and it shall not be possible for the holders to swing inside the enclosure.
- H. Doors shall automatically self lock open.

2.06 Ventilation System

- A. Ventilation system shall be provided along the bottom and top at each side of the enclosure.
- B. Each vent shall have an inside baffle to protect against insertion of foreign objects, or shall be so constructed as to prevent insertion of foreign objects.

2.07 Finish

- A. During fabrication, the areas of structural parts which may later become inaccessible, such as folded edges and overlapping members, shall be given a phosphatizing bath and an iron-oxide zinc-chromate anti-corrosion primer to ensure that all surfaces are protected.

- B. Any welds made by other than the gas-shielded short-circuiting transfer welding process shall be ground and sanded (wire brushed if internal) to remove all scale and alkaline residues formed during welding.
- C. Full coverage at joints and blind areas shall be achieved by processing enclosures independently of components such as doors and roofs before assembly into the utilized structures.
- D. All exterior seams shall be filled and sanded smooth for neat appearance.
- E. To remove oils and dirt, and to form a chemically and anodically neutral conversion coating to improve the finish-to-metal bond, and to retard underfilm propagation of corrosion, all surfaces shall undergo a thorough pretreatment process before any protective coatings are applied.
- F. After pretreatment, protective coatings shall be applied that shall help resist corrosion and protect the steel enclosure. To establish the ability of the finishing system to resist corrosion and protect the enclosure, representative test specimens shall satisfactorily pass the following tests:
 - 1. 1000 hours of exposure to salt-spray testing per ASTM B 11 7-73 with loss of adhesion from bare metal not to extend more than 1/8" and underfilm corrosion not to extend more than 1/32" from the scribe.
 - 2. 1000 hours of humidity testing per ASTM D 2247 with the formation of no more than #6 medium blisters as evaluated per ASTM D 714-56.
 - 3. 500 hours of accelerated weather testing per ASTM G 53-77 with no more than 25% reduction of paint gloss.
 - 4. Crosshatch adhesion testing per ASTM D 3359 Method B with no loss of paint.
 - 5. 160 inch-pound impact adhesion testing per ASTM D 2794-69 with no paint chipping or cracking.
 - 6. Certified test abstracts substantiating such capabilities shall be furnished with the bid.
- G. The finishing system shall be applied without sags or runs for a pleasing appearance.
- H. After the finishing system has been properly applied and cured, welds along the enclosure bottom flange and around the door hinges shall be coated with a wax-based anti-corrosion moisture barrier to give these areas added corrosion resistance. Weld studs within the enclosure that are not covered by nuts shall be coated with an oxide-inhibiting compound to help guard against corrosion starting on the exposed threads.
- I. After the enclosure is completely assembled and the components (switches, fuses, bus, etc.) are installed, the finish shall be inspected for scuffs and scratches. Blemishes shall be carefully touched up by hand to restore the protective integrity of the finish.
- J. The finish shall be sage green. Contractor shall sand finish with #220 grit dual action Sander Prime with duPont Vari Prime #815/8165 and apply 3 wet coats of duPont catalyzed acrylic enamel. Color is Federal Standard 595b, 14449.

2.08 Corrosion

- A. To guard against corrosion, all hardware (including door fittings, fasteners, etc.), all operating-mechanism parts, and other parts subject to abrasive action from mechanical motion shall be of either non-ferrous materials, or galvanized, or zinc-plated ferrous materials. Cadmium-plated ferrous parts shall not be used.

2.09 Tamper Resistance

- A. In consideration of tamper resistance, the enclosure shall withstand a prying leverage of 75 foot-pounds applied to all joints, crevices, hinges, seams and locking means. All such openings shall prevent insertion of number 10 AWG hard-drawn copper wire after the prying leverage has been applied.

2.10 Interrupter Switches

- A. Interrupter switches shall have a two-time duty-cycle fault-closing rating equal to or exceeding the short-circuit rating ability to close the interrupter switch twice against a three-phase fault with asymmetrical current in at least one phase equal to the rated value, with the switch remaining operable and able to carry and interrupt rated current. Tests substantiating these ratings shall be furnished with the bid.
- B. Interrupter switches shall be operated by means of an externally accessible 3/4 inch hex switch-operating hub. The switch-operating hub shall be located within a recessed pocket mounted on the side of the pad-mounted gear enclosure and shall accommodate a 3/4 inch deep-socket wrench or a 3/4 inch shallow-socket wrench with extension. The switch-operating hub pocket shall include a pad lockable access cover that shall incorporate a hood to protect the padlock shackle from tampering. Stops shall be provided on the switch operating hub to prevent over travel and thereby guard against damage to the interrupter switch quick-make, quick-break mechanism.
- C. Interrupter switches shall utilize a quick-made, quick-break mechanism installed by the switch manufacturer. The quick-make, quick-break mechanism shall be integrally mounted on the switch frame, and shall swiftly and positively open and close the interrupter switch independent of the switch independent of the switch-operating hub speed. Switches shall be the air break type.
- D. Each interrupter switch shall be completely assembled and adjusted by the switch manufacturer on a single rigid mounting frame. The frame shall be of welded steel construction such that the frame intercepts the leakage path which parallels the open gap of the circuit when the interrupter switch is in the open position.
- E. Interrupter switch contacts shall be of silver-to-silver construction for optimum current transfer, and shall be backed up by stainless steel springs to provide constant high contact pressure.
- F. Interrupter switches shall be provided with a single blade per phase for circuit closing including fault closing, continuous current carrying, and circuit interrupting. Spring-loaded auxiliary blades shall not be permitted. Interrupter switch blade supports shall be permanently molded in place in a unified insulated shaft constructed of the same cycloaliphatic epoxy resin as the insulators.
- G. Circuit interruption shall be accomplished by use of an interrupter which is positively and inherently sequenced with the blade position. It shall not be possible for the blade and interrupter to get out of sequence. Circuit interruption shall take place completely within the interrupter, with no external arc or flame. Any exhaust shall be vented in a controlled manner through a deionizing vent.
- H. Interrupter switches shall have a readily visible open gap when in the open position to allow positive verification of correct switch position.
- I. Each interrupter switch shall be provided with a folding switch-operating handle. The switch-operating handle shall be secured to the inside of the switch-operating hub pocket by a brass chain. The folded handle shall be stored behind the closed switch-operating-hub access door.
- J. Key interlocks shall be provided between each fuse-compartment door and all switches to guard against opening fuse-compartment door(s) unless all switches are locked open.

- K. Grounding studs shall be provided at all switch terminals. Grounding studs shall also be provided on the ground pad in each interrupter switch compartment and on terminals and ground pads in any cable-termination compartment. The momentary rating of the grounding studs shall equal or exceed the short-circuit ratings of the pad-mounting gear.
- L. Mounting provisions shall be provided to accommodate one three-phase fault indicator with three single-phase sensors in each switch compartment on units with more than one switch position.

2.11 Fuses

- A. Fuses shall be disconnect style, solid-material power fuses, and shall utilize refill-unit-and-holder construction. The refill unit or fuse unit shall be readily replaceable and low in cost.
 - 1. Fusible elements shall be non-aging and non-damageable so that it is unnecessary to replace unblown companion fuses on suspicion of damage following a fuse operation.
 - 2. Fusible elements for refill units, rated 10 amperes or larger, shall be helically coiled to avoid mechanical damage due to stresses from surges.
 - 3. Fusible elements shall be supported in air to allow cooling after current surges to help prevent damage.
 - 4. Each refill unit shall have a single fusible element to eliminate the possibility of unequal current sharing in parallel current paths.
 - 5. Power fuses shall have melting time-current characteristics that are permanently accurate to within a total of 10% in terms of current. Time current characteristics shall be available which permit coordination with protective relays, automatic circuit reclosers, and other fuses.
 - 6. Power fuses shall be capable of detecting and interrupting all faults whether large, medium, or small (down to minimum melting current), under all realistic conditions of circuitry, with line-to-line or line-to-ground voltage across the power fuse, and shall be capable of handling the full range of transient recovery voltage severity associated with these faults.
 - 7. All arcing accompanying power fuse operation shall be contained within the fuse, and all arc products and gases evolved during fuse operation shall be vented through an exhaust control device that shall effectively control fuse exhaust.
 - 8. Power fuses shall be equipped with a blown-fuse indicator that shall provide visible evidence of fuse operation while installed in the fuse mounting.
 - 9. Fuses shall be S&C type SML-4Z units which accept type SM-4 refill units.
- B. Fuse-mounting jaw contacts shall incorporate an integral load interrupter that shall permit live switching of fuses with a hook stick.
 - 1. The integral load interrupter housing shall be of the same cycloaliphatic epoxy resin as the insulators.
 - 2. The integral load interrupter shall be in the current path continuously. Auxiliary blades or linkages shall not be used.
 - 3. Live switching shall be accomplished by a firm, steady opening pull on the fuse pull ring with a hook stick. No separate load-interrupting tool shall be required.
 - 4. The integral load interrupter shall require a hard pull to unlatch the fuse to reduce the possibility of an incomplete opening operation.
 - 5. Internal moving contacts of the integral load interrupter shall be self-resetting after each opening operation to permit any subsequent closing operation to be performed immediately.
 - 6. Circuit interruption shall take place completely within the integral load interrupter with no external arc or flame.
 - 7. The integral load interrupter and the fuse shall be provided with separate fault-closing contacts and current-carrying contacts. The fuse hinge shall be self-guiding and, together with the fault-closing contacts, shall guide the fuse into the current-carrying contacts during closing operations. Circuit-closing inrush currents and fault currents shall be picked up by the fault-closing contacts, not by the current-carrying contacts or interrupting contacts.

8. Integral load interrupters for power fuses shall have a one-time duty-cycle fault-closing capability equal to the interrupting rating of the fuse, and a two-time duty-cycle fault-closing capability of 13,000 amperes RMS asymmetrical at 14.4 KV or 25 KV. The duty-cycle fault-closing capability defines the level of available fault current into which the fuse can be closed the specified number of times (once or twice), without a quick-make mechanism and when operated vigorously through its full travel without hesitation at any point, with the integral load interrupter remaining operable and able to carry and interrupt remaining operable and able to carry and interrupt currents up to the emergency peak-load capabilities of the fuse.
- C. Fuse terminal pads shall be provided with a two-position adapter. This adapter shall accommodate a variety of cable-terminating devices.
- D. Grounding studs shall be provided at all fuse terminals. One grounding stud shall also be provided on the ground pad in each fuse compartment. The momentary rating of the grounding study shall equal or exceed the short-circuit ratings of the pad-mounted gear.
- E. A full set of fuses, plus a full set of spare fuse refills, shall be provided for each fuse position as shown on the one line diagram.

2.12 Warning Signs

- A. All external doors shall be provided with permanent "Caution - High Voltage -Keep out" signs.
- B. The inside of each door shall be provided with "Danger - High Voltage -Qualified Persons Only" signs (Bilingual English, Spanish and Japanese).
- C. The inside each door providing access to interrupter switches shall be provided with warning signs indicating that "Switch Blades May Be Energized In Any Position".
- D. The inside of each door providing access to power fuses shall be provided with permanent warning signs indicating that "Fuses May Be Energized in Any Position".
- E. All warning signs shall be provided in both English and Spanish.

2.13 Rating Nameplates and Connection Diagrams

- A. The outside of each door (or set of double doors) shall be provided with nameplates indicating the manufacturer's name, catalog number, and model number.
- B. The inside of each door (or set of double doors) shall be provided with nameplates indicating the following: voltage ratings (kv, nominal; kv, maximum design; and kv, BIL); main bus continuous rating (amperes); short-circuit ratings (amperes, RMS symmetrical and Mva three-phase symmetrical at rated nominal voltage); the type of fuse and its ratings (amperes, one-time/two-time duty-cycle fault-closing capability); and interrupter switch ratings (amperes, continuous; amperes, live switching - load splitting and load dropping; amperes, fault-closing, duty-cycle, two-time RMS symmetrical, RMS asymmetrical, and one-second symmetrical).
- C. A three-line connection diagram showing interrupter switches, fuses with integral load interrupter, and bus along with the manufacturer's model number shall be provided on the inside of the front and rear doors (or set of double doors), and on the inside of each switch-operating-hub access cover.

2.14 Auxiliaries

- A. Holders, and refill units for original installation, as well as one spare fuse unit or refill unit for each fuse mounting shall be furnished.
- B. A fuse handling tool as recommended by the fuse manufacturer shall be furnished.

- C. One bolted connector per phase accommodating NO.2 solid through 500 MCM stranded copper or aluminum conductor shall be furnished for all switch and fuse positions.

2.15 Three-Phase Fault Indicator

- A. A three-phase fault indicator shall be provided and installed with three single phase sensors in each switch compartment on all units.
- B. Fault indicators shall be provided at switching points on distribution circuits and unfused taps. A fault indicator shall be provided for each phase. Trip setting shall be as required for the given circuit. Reset shall be automatic and initiated by normal current. Fault indicators shall be type CR (10) manufactured by RTE Corporation, Waukesha, Wisconsin, or approved equal.

PART 3 INSTALLATION

3.00 Installation

- A. The switch assembly shall be mounted securely on a concrete pad minimum of six inches in thickness, designed adequately for the weight of the switch. The pad shall extend a minimum of 3' from the front of each set of doors. The switch shall be securely anchored to the pad per the manufacturer's recommendations. A ground loop shall circle the switch and provisions for grounding the switch and landing any grounds or shields shall be provided for within the enclosure. During installation all internal shields shall be left inside of the switch and shall not be left out of the cabinet or subject to exposure to the elements. Any shield which has been damaged due to neglect or exposure to the elements shall be replaced to the satisfaction of the University of Arizona Electrical Engineer.

End of Appendix Section 16310

Section 16320 - PAD MOUNT TRANSFORMER

PART 1 GENERAL:

1.01 Work Included Herein

- A. Pad mount transformer installations.

PART 2 PRODUCTS:

2.01 MANUFACTURER

- A. Acceptable Manufacturers:
 - General Electric
 - Square D
 - Cooper
 - Cutler Hammer*

2.02 TESTING

- A. Testing shall be performed in accordance with ANSI C57.12, IEEE standards 48 and 93, NEMA TRi and TR5, and ASTM D3487.

2.03 SUBMITTALS

- A. Provide complete submittals and shop drawings on the unit including the following:
 1. Shop Drawings and catalog cuts
 2. Sufficient information to determine compliance with specifications.
 3. Include all electrical ratings, nameplate data, impedance, dimensions, weight, mounting, footprint, material, decibel ratings, terminations, temperature rise, no load and full load losses, regulation, overcurrent protection, connection diagrams, fuse sizes, fuse curves with transformer damage points, and accessories.

2.04 POWER TRANSFORMERS

- A. The transformer shall be of the *non burning or high flash point* liquid filled type. The unit shall be designed for outdoor installation a temperature variations from 0 to 45 degrees Celsius at 5% to 95% relative humidity. Cooling oil shall be in accordance with ASTM D3487.

- B. Transformer shall have the following characteristics:

1.	Continuous rating, KVA	XXX KVA
2.	Number of phases	3
3.	Number of windings	3
4.	Frequency, hertz	60
5.	Impedance, at rated KVA	5.75%
6.	High voltage winding, volts	13,800/4160 dual rated
7.	Low voltage winding, volts	120/208
8.	Temperature Rise	65° C Resistive and 80° hot spot

- C. Connections:

1.	High-voltage winding	delta
2.	Low-voltage winding	wye
3.	Taps 2@+/-2.5%	yes
4.	Basic Insulation Level (BIL)	
5.	high-voltage winding, kV	95
- D. The windings shall have insulation of high dielectric and mechanical strength and shall be arranged to permit free circulation of cooling medium. Proper internal barriers shall be provided and additional insulation shall be provided on end coils to protect against line disturbances. The coils shall be adequately braced to prevent distortion due to any abnormal operating conditions. The windings shall withstand impulses, induced and dielectric test voltage in accordance with ANSI Standard C57.12.00.
- E. The transformers shall be furnished with a primary no-load tap changer. The transformer shall be provided with four (4) approximately 2-1/2% full capacity taps in the high voltage winding, two below and two above normal, brought out to an externally-operated, de-energized tap changer. The tap changer handle shall be capable of being locked in any tap position.
- F. The transformers shall be provided with an indicating dial thermometer, having a range from 0 degrees C. to 1 20 degrees C., indicating the transformer winding temperature.
- G. The transformers shall be furnished with two suitable ground pads on opposite sides near the bottom. The ground pads shall include a flat finished surface with NEMA drilling.
- H. The base of each transformer shall be provided with jacking pads.
- I. The transformers shall be provided with an approved nameplate conforming to the requirements of ANSI Standard C57.12.00.
- J. All windings shall be copper. Fillers or tie downs shall be provided for the coil windings.
- K. Cores shall be rigidly braced grain oriented, non aging silicon steel to minimize losses

2.05 PRIMARY EQUIPMENT

- A. The primary connections shall be live front. NOTE: Units shall have all dead front features with the exception of bolted spade type primary bushings.
- B. The primary switch shall be a gang operated load break oil immersed disconnect switch.
- C. The primary fuses shall be non load rated dry well mounted current limiting primary fuses.
- D. The entire transformer shall be of a single unit.
- E. One set of spare primary fuses shall be provided for the transformer.
- F. Provide distribution class surge arresters in the primary terminal compartment to protect the transformer primary. The arresters shall be rated at 10kv.

2.06 SECONDARY EQUIPMENT

- A. The low voltage leads shall be brought out of the tank by epoxy, pressure tight bushings, using the standard arrangement per ANSI. The neutral terminal shall be isolated from the transformer tank. A removable bonding jumper shall be provided from the secondary neutral to ground. The bonding jumper shall be sized in accordance with the NEC.

2.07 ENCLOSURE AND DOORS

- A. The enclosure of the transformer shall be of tamper resistant construction with no exposed screws, bolts, or other fastening devices which are externally removable.
- B. The doors shall be designed and constructed to guard against unauthorized entry.
 - 1. The high voltage compartment door shall be latched with captive bolts accessible only after the low voltage door is released and opened.
 - 2. The low voltage door shall have three point latching with a pentahead type captive bolt in the door handle for additional security. Provisions for padlocking the handle shall be included whereby the padlock cannot be engaged until the captive bolt is seated.
 - 3. Access to the tank hand hole shall be only after the low and high voltage compartment doors are opened.
 - 4. A rigid steel partition shall separate the high and low voltage compartments.
 - 5. The doors shall have full return baffles on the edges and have concealed latching mechanisms and hinges to provide maximum resistance to prying or probing with sticks, rods, or wires.
- C. Exothermically weld pad ground conductor to transformer ground pad.
- D. *Transformer shall be painted white, Dupont #817. Sand with 220 grit paper, prime with Dupont Vari-Prime, apply 3 coats of Dupont catalyzed urethane color.*

2.08 TRANSFORMER TANK

- A. Transformer tank shall be of sealed construction of sufficient strength to withstand a pressure on 7 psi without permanent distortion.
- B. The following shall be provided on the wall on the tank inside of the locked low voltage compartment of the transformer:
 - 1. Drain valve and sampling device
 - 2. Pressure Relief valve
 - 3. Oil filling plug
 - 4. Oil level plug
 - 5. Non corrosive metal nameplate
 - 6. Ground pad
 - 7. Oil Level gage
 - 8. Dial type thermometer
 - 9. Pressure/vacuum gage
- C. The following shall be provided on the wall on the tank inside of the locked high voltage compartment of the transformer:
 - No load tap changer handle
 - Ground pad
 - Bayonet fusing
 - Lightning arresters
- D. On the door of the secondary compartment shall have provisions for mounting a 1 5 kv rated hot stick. Hot stick shall be provided with transformer.

PART 3 EXECUTION

3.1 INSTALLATION

- A. Install complete transformer pad as indicated on drawings. Pad shall have block outs for minimum of 2 additional primary and 4 additional secondary conduits.
- B. Transformer shall be securely bolted to the concrete foundation pad in accordance with the manufacturer's recommendations.
- C. *Exothermically weld pad ground conductor to transformer ground pad.*

3.2 TESTING

- A. The manufacturer shall perform the following tests on each transformer prior to shipment and furnish the test results to the U of A electrical Engineer.
 - 1. Resistance measurements, ratios, polarity, and phase relation tests
 - 2. No load core loss and exciting current at rated voltage
 - 3. Impedance and load loss
 - 4. Applied potential test
 - 5. Induced potential test
 - 6. Pressure leak test
 - 7. Audible sound levels
 - 8. Temperature rise
 - 9. Impedance
 - 10. Verification of compliance from prototype testing and conformance verification
- B. Notify the U of A engineer , in writing when the transformers are ready for field testing.
- C. The electrical contractor shall adjust, test, and place the equipment into operation to the complete satisfaction of the U of A Electrical Engineer.

End of Section 16320

Section 16425- MOTOR CONTROLLERS AND CONTACTORS**Introduction****Part 1 – General**

- Related Work
 - Section 16195- Electrical Identification.
 - Section 16440- Enclosed Disconnect Switches and Circuit Breakers.
 - Section 16475- Overcurrent Protective Devices.
- Reference
 - The Work under this section is subject to requirements of the Contract Documents including the General Conditions, Supplementary Conditions, and sections under Division 1 General Requirements.
- Description of Work
 - All motors will be provided ready for connections.
 - This Contractor responsible for proper phase relationships, and correct motor rotation.
 - Provide power circuit wiring for each motor from source of supply to terminal box on motor including required intermediate connections at devices such as motor starter, disconnect switches, etc.
 - Provide power circuit disconnects devices unless shown or specified to be furnished by other divisions or the owner.
 - Provide connecting lugs for equipment specified in this Section as well as for equipment furnished by other divisions or the owner.
 - Provide motor starters as specified for motors unless shown or specified to be furnished by other divisions or the owner. VDF drives shall be provided under division 15.
 - Provide control devices shown on motor schedule or as otherwise indicated.
 - Provide control wiring (except temperature control wiring) for operation, control and supervision of motorized equipment including wiring between motor starters and control devices specified and as shown on drawings.
 - Motor control wiring shall be installed in accordance with control wiring diagrams.
 - Motors ½ HP and smaller shall be served with 120 volts, single phase.
 - Motors ¾ HP and larger shall be served with 480 volt, 3 phase.
 - Starters for NEMA rated 460- volt motors 60 HP and above shall be reduced voltage starting type.
 - Reduced voltage starters shall be auto transformer type, closed transition.
- Reference Standards
 - ASME/ANSI A17.1 Safety Code for Elevators and Escalators.
 - NEMA ICS 1 Industrial Control and Systems: General Requirements.
 - NEMA ICS 2 Industrial Control and System: Controllers, Contactors and Overload Relays, rated not more than 200 Volts AC or 750 Volts DC.
 - NEMA AB- 1 Molded Case Circuit Breakers and Molded Case Switches.
 - NEMA KS- 1 Enclosed and Miscellaneous Distribution Equipment Switches (600 Volt Max.)
 - NEMA 250 Enclosures for Electrical Equipment (1000 Volts Maximum)
 - UL 580 Electric Industrial Control Equipment.
 - UL 845 Electric Motor Control Centers.

- Submittals
 - The design shown in the contract documents is based on the first listed manufacturer. If any of the other listed manufacturers are provided the performance of the equipment shall be equal to or exceed the first listed manufacturer and result in clean coordination and an uncompromised distribution system.
 - Shop drawings for equipment provided under this Section.

Part 2 - Products

- Manufacturers
 - Cutler Hammer, Allen Bradley, General Electric, Siemens.
- Motor Control Equipment
 - Motor Starters:
 - Starters to be equipped with temperature compensated bi-metal overload relays with manual reset.
 - Manual starter to have melting alloy thermal overload relay.
 - Thermal units shall be selected on basis of nameplate horsepower, service factor and full load amps for particular motor.
 - Thermal units shall be selected on basis of measured actual full load amps of particular motor. Sizing shall be done with motor and driven device in its final and normal operating condition. Provide temporary heaters for each starter until motor is in proper operating condition, and replace with heaters sized to actual full load amps.
 - Each starter operating at other than 120 volts single phase shall have control transformer providing 120- volt control power to supply connected load plus 100% spare capacity.
 - Transformer shall have fused primary and secondary circuits.
 - Coils and pilot lights to be 120 volt. Provide surge suppressor across coil.
 - Manual starters shall be equipped with pilot light.
 - Starters shall be equipped with the following:
 - “Hand-Off-Auto” (H-O-A) selector switch.
 - 4 NO and 4 NC set of auxiliary contacts.
 - Red pilot light to indicate motor operation.
 - Green pilot light to indicate motor stopped.
 - Amber pilot light to indicate H-O-A switch in auto position.
 - Pilot lights shall be “Push-To-Test” type.
 - NEMA 3R enclosures shall also be gasketed.
 - Multi speed Starters:
 - Multi speed starters shall be equipped same as single-speed starters with addition of:
 - Speed selector switch.
 - “Auto-Off-Low-High” selector switch.
 - Compelling relay.
 - Accelerating relay/timer.
 - Decelerating relay/timer.
 - Reduced Voltage Motor Starters:
 - Autotransformer starter:
 - Closed transition.

- Magnetic Contactors:
 - Magnetic contactors shall be same as magnetic starters, except without overload protection.
- Motor Disconnect Devices:
 - Refer to Section 16440 –Disconnect Switches for disconnect switches not located in motor control centers.
 - Provide disconnect device with type FRN rejection full size fuses rated minimum of 600 volts Connected in line side of each starter.
 - Provide non-fused disconnect device at all motors.
 - Provide non-fused disconnect device at motors located on roof or located on floor different from overcurrent protective device.
 - Disconnect device shall be capable of being locked in open position.
 - Disconnect devices shall be:
 - Heavy-duty safety switch, quick-make, quick-break, horsepower rated.
 - Fused disconnect switches shall be equipped with Class RK-5 time delay fuses.
- Individual Starters and Disconnect Devices
 - Starter and disconnect device shall be installed in common enclosure, combination type, with accessories mounted in enclosure front except as scheduled.
 - Provide padlocking facility for one to three padlocks to lock disconnect in either ON or OFF position with door open or closed.
 - Provide mechanical interlock to prevent opening of door unless disconnect is in OFF position. Provide defeater to by-pass this interlock.
 - Remote disconnect switches for motors supplied from variable frequency drives (VFD) shall be equipped with pivot arm electrical interlock kit consisting of 4 NO and 4 NC contacts. Contacts to break control circuits before main switchblades open and close control circuits after main switchblades close.
 - Enclosures shall be: NEMA 1, NEMA 4X SS or NEMA 3R/12 by the spaces they are installed. NEMA 4X SS enclosures shall be required in, mechanical rooms, the main electrical equipment room, generator room, main emergency electrical room and for enclosures located exposed to the weather.
- Motor Control Centers
 - Motor Control Centers:
 - Install starters and disconnects in motor control centers, except where shown to be remote mounted at motor location.
 - Provide main breaker in the MCC, fully electronic type LSI/LSIG.
 - Motor Control Centers Shall Be:
 - 480Y/277 Volts, 3 phase 4 wire.
 - NEMA 1A gasketed enclosure except NEMA 3R gasketed enclosure in the main electrical equipment room, generator room and main emergency electrical room.
 - NEMA Class II.
 - NEMA Type B wiring.
 - Structure shall:
 - Consist of one or more vertical sections joined together to form a freestanding assembly.
 - Be minimum of 90" high, 20" wide and 15" deep for front mounted units or 20" deep for back-to-back units.
 - Have base channels with holes for bolting to floor.
 - Be designed to add matching sections on either end at future date.
 - Bus:
 - Bracing at 65,000 amps symmetrical.

- Shall be copper-tin plated.
- Horizontal Bus amp as shown on plans.
- Vertical bus size shall be same size a horizontal bus size.
- 50% Ground Bus size per NEMA standard.
- 400 AMP MCC's shall have each section rated 400 AMP.
- 300 AMP sections are not permitted.

- Wire ways:
 - Horizontal wire ways at top and bottom of structure.
 - Vertical wire way full height of each section.

- Lifting Eyes
 - Provide permanent mounted lifting eyes on all equipments shipped to the site for installation by the Contractor. Lifting eyes shall be heavy duty forged steel, located to facilitate equipment installation and removal and shall not be removed after construction is complete.

Part 3 – Execution

- Installation
 - Provide 120 volts to each temperature control panel.
 - Install disconnects and motor control equipment as indicated. Final location of devices shall be determined in field.
 - Provide NEMA 4 disconnect switches at exterior mounted equipment.
 - Each motor terminal box shall be connected to rigid conduit system with maximum 18" of flexible liquid-tight metal conduit.
 - Provide green wire ground through flexible conduit to interconnect motor frame and rigid conduit system.
 - Check for proper rotation of each motor.
 - Install fuses per manufacturer's instructions.

- Elevator Connections
 - Provide power wiring from source through circuit breaker disconnect to elevator controller to motor.
 - Coordinate entire installation with elevator equipment supplier prior to rough in.
 - Installation shall comply with ASME/ANSI A17.1: Safety Code for Elevators and Escalators.

End of Appendix Section 16425

Section 16435 - SWITCHBOARDS**Introduction****Part 1 - General**

- Related Work
 - Section 16070 – Seismic Anchorage and Restraint
 - Section 16075 – Electrical Identification
 - Section 16080 – Power Distribution Acceptance Testing
- Reference
 - The work under this section is subject to requirements of the Contract Documents including the General Conditions, Supplementary Conditions, and sections under Division 1 General Requirements.
- Description
 - Contractor shall furnish and install free-standing, dead-front type low-voltage distribution switchboards, utilizing group mounted circuit protective devices.
- Reference Standards
 - ANSI C37.13 – IEEE Standard for Low-Voltage AC Power Circuit Breakers Used in Enclosures
 - ANSI C37.17 – Trip Devices for AC and General Purpose DC Low-Voltage Power Circuit Breakers
 - NEMA PB2 – Dead Front Distribution Switchboards
 - NEMA KS 1 – Enclosed and Miscellaneous Distribution Equipment Switches (600 Volts Maximum)
 - UL 489 – Molded-Case Circuit Breakers, Molded-Case Switches, and Circuit-Breaker Enclosures
 - UL-891 – Dead Front Switchboards
- Submittals
 - Shop Drawings
 - Submit shop drawings for equipment provided under this section
 - Shop drawings shall indicate:
 - Manufacture and model numbers of equipment and devices
 - General arrangement:
 - Plan view indicating overall dimensions, shipping splits and weights
 - Front elevation indicating location of devices and instruments
 - Section through switchgear showing space available for conduits
 - Seismic certification and equipment anchorage details
 - Electrical one-line drawings
 - Short circuit ratings of bus and interrupting rating of lowest rated device
 - Circuit schedules showing feeder circuit identification, device description, including trip unit or fuse clip rating
 - Schematic wiring diagram
 - Cable lug termination device
 - Time current characteristics curves
 - Main breakers
 - Feeder breakers
 - Ground fault relaying

- Test data
 - Submit power distribution acceptance test reports to Engineer for review and acceptance, prior to energization of equipment.
- Instruction Manuals
 - In addition to Section 16000 – General Electrical Requirements, manual shall include the following:
 - Wiring diagrams for all systems.

Maintenance and Spare Parts

- Provide list of recommended spare parts
- Delivery, Storage, And Handling
 - Upon completion, assembly and testing by manufacturer of equipment specified, should it be found necessary for shipping and installation purposes to disassemble equipment, match-mark parts to facilitate erection in field.
 - Mark crates, boxes and cartons clearly to identify equipment. Show crate, box or carton identification number on shipping invoices.
 - Store switchboard units in clean, dry environment protected from elements. Maintain factory bracing, packaging and wrapping.
 - Handle units in accordance with manufacture's written handling instructions. Lift units only by manufacturers approved means.

Part 2 - Products

- Materials
 - Acceptable Manufactures: Cutler-Hammer, General Electric, Siemens
- Ratings
 - Assembly shall be rated to withstand fault current as shown on drawing
 - Nominal system voltage rating of switchboard shall be as shown on the drawings.
- Construction
 - Switchboard shall consist of vertical sections bolted together. Sides and rear shall be covered with removable bolt-on covers. Provide adequate ventilation within enclosure.
 - Switchboard sections shall be rear aligned. Protective devices shall be group mounted. Devices shall be front removable and load connections front accessible.
 - Assembly shall be provided with adequate lifting means.
 - Switchboard shall be suitable for use as service entrance equipment.
- Bus
 - General
 - Bus bars shall be silver-plated copper.
 - Main horizontal bus bars shall be mounted with all three phases arranged in same vertical plane.
 - Bus sizing shall be based on 65°C over 40°C ambient temperature outside the enclosure.
 - Provide a full capacity neutral bus.
 - Provide copper ground bus, sized per NEMA Standards, extending entire length of switchgear.

- Bus Bar Connection
 - Bus bar connections shall be bolted.
 - Bus joints shall be provided with conical spring-type washers.
 - Clamp joints shall not be used.
- Wiring Terminations
 - Provide small wiring, necessary fuse blocks and terminal blocks within switchboard.
 - Control components mounted within assembly, such as fuse blocks, relays, pushbuttons, switches, etc., shall be suitably marked for identification corresponding to appropriate designations on manufacturer's wiring diagrams.
 - Mechanical-type terminals shall be provided for all line and load terminations suitable for copper cable rated for 75°C.
 - Lugs shall be provided in incoming line section for connection of main grounding conductor.
 - Control wire shall be type SIS.
 - Control wire shall be bundled and secured with nylon ties.
 - Insulated locking spade terminals shall be provided for all control connections, except where saddle type terminals are provided integral to a device.
 - Current transformer secondary leads shall be connected to short-circuit terminal blocks.
 - Groups of control wires leaving the switchboard shall be provided with terminals blocks with suitable numbering strips. Provide wire markers at each end of control wiring.
- Protective Devices
 - Main Breaker
 - Main breaker shall be fixed insulated case circuit breaker, fully electronic, LSIG/LSI.
 - Breaker shall be listed for 100% continuous ampere rating.
 - Main breaker shall be provided with solid-state trip units.
 - Frame ampere ratings shall be as shown on drawings.
 - Main breakers shall be manually operated (MO).
 - Feeder Breakers
 - Feeder breakers shall be fully electronic molded case circuit breakers or Power Circuit Breakers, LSI. Thermal magnetic breakers are not acceptable.
 - Circuit breakers shall have minimum of symmetrical interrupting capacity as indicated on drawings.
 - Circuit breakers 200-ampere through 2500-ampere shall have microprocessor-based RMS sensing trip units.
 - Solid State Trip Units
 - Provide breakers, with solid-state microprocessor based trip units.
 - Unit shall consist of current sensors, solid-state trip device, flux transfer shunt trip and solid-state adjustable time/current curve shaping elements.
 - Solid state elements shall provide:
 - Long time current pickup settings and long time delay bands.
 - Short time current pickup settings and short time delay bands.
 - Instantaneous trip settings with switchable 12t ramp.
 - Ground fault pickup settings (where indicated on drawings).
 - Adjustments shall be made using non-removable, discrete steps.
 - Sealable transparent cover shall be provided over adjustments.

- Ground Fault (where indicated on drawings):
 - Trip shall be provided as an integral part of breaker.
 - Pick-up shall be adjustable with maximum setting of 1200 amps.
 - Time delay shall be adjustable.
- Trip unit shall contain means to conduct circuit breaker tests.
- Breaker shall be equipped with externally accessible test points to be used for field testing.

- Customer Metering
 - Provide customer metering compartment with hinged door.
 - Current transformers for each meter. Current transformers shall be wired to shorting-type terminal blocks.
 - Potential transformers including primary and secondary fuses with disconnecting means.
 - Meter shall be microprocessor-based as manufactured by Veris.
 - The unit shall display the following:
 - Phase amperes (A, B, C).
 - Phase voltage (A-B, B-C, C-A, A-N, B-N, C-N).

- Enclosures
 - NEMA 1 Enclosure
 - Finish
 - Exterior and interior of switchboard shall be ANSI-61 light gray.

- Accessories
 - Lockout Devices:
 - Provide circuit breakers with integral, lockout/tagout devices.
 - Shunt trip devices:
 - Provide shunt trip bell alarms and auxiliary switches.

- Nameplates
 - Nameplates shall be secured to switchboard enclosure with screws.
 - Switchgear assembly:
 - Switchgear shall be provided with nameplate indicating manufacturer's name and drawing number.
 - In addition to name and drawing number, provided:
 - Voltage ratings (kV nominal; kV maximum design; kV BIL)
 - Main bus continuous rating (amperes)
 - Short-circuit ratings (amperes, rms symmetrical and Mva three-phase symmetrical)
 - Momentary and fault-closing ratings (amperes, rms asymmetrical)
 - Control components mounted within assembly shall be marked for identification corresponding to appropriate designation on manufacture's drawings.

Part 3 - Execution

- Inspection
 - Visually inspect equipment and components at time of delivery. Submit report to Owner/Engineer with list of items to be corrected.

- Factory Testing
- Standard Factory Tests Shall Be Performed On Equipment Provided Under This Section.
 - Switchboard shall be completely assembled, wired, adjusted, and tested at factory.
 - Manufacturer shall provide 3-certified copies of factory test reports.
- Installation
 - Contractors shall install equipment per manufacturer's instructions and contract drawings.
 - Assembly shall be provided with adequate lifting means and shall be capable of being moved into installation position and bolted directly to floor without use of floor sills provided floor is level to 1/8 inch per 3-foot distance in any direction. Necessary hardware to secure assembly in place shall be provided by Contractor.
 - Provide 4-inch high housekeeping pad for switchboards as indicated on drawings. Pad footprint shall be size to adequately support switchboard. Bolt switchboard securely to pad.
 - Protect equipment during installation to prevent twisting or deformation, exposure to damaging environments, and work of other trades. Maintain protection until completion of construction.
 - Prior to energization, factory representative shall visually inspect switchgear installation to insure that switches and motor operators are operable and bus connections are complete.
- Field Quality Control
 - Contractor shall perform field adjustments of protective devices as required to place equipment in final operating condition. Settings shall be in accordance with approved short-circuit study, protective device evaluation study and protective device coordination study.
 - Necessary field settings of devices and adjustments and minor modifications to equipment to accomplish conformance with approved short circuit and protective device coordination study shall be carried out by Contractor at no additional cost to Owner.
 - Immediately prior to final inspection, thoroughly clean equipment. Refinish damaged enclosures to original quality.
- Acceptance Testing
 - Perform Acceptance tests on switchboard in accordance with Section 16080 – Power Distribution Acceptance Tests. Adjust or replace equipment as needed to comply with manufacturer's specifications. Re-test device and submit new test reports.
 - Equipment shall have passed acceptance tests prior to energization.
 - Certified test report of standard production tests shall be available to Engineer upon request.
 - Switch operators shall be tested at least once after energization.
- Training
 - Contractor shall provide training session for up to [XXX] Owner's Representatives for one normal workday at a jobsite location determined by Owner.
 - Training session shall be conducted by Manufacturer's Qualified Representative. Training program shall consist of instruction on operation of assembly, circuit breakers, fused switches, and major components within assembly.

End of Appendix Section 16435

Section 16620 - NATURAL GAS ENGINE GENERATOR SET

PART I-GENERAL

1.1 GENERAL

PROJECT NO.

- A. The requirements specified in GENERAL - general requirements of this project shall apply to and govern the work under CSI Division I except where indicated in the following articles.

1.2 WORK INCLUDED

- A. Provide all labor, materials and equipment to furnish, install and place in operation a natural gas power generation system in accordance with the contract documents and manufacturer's drawings and installation instructions. These specifications also describe requirements for the design, fabrication and testing of the power system. The total installation shall conform to manufacturer's recommendations.
- B. The installation of the power generation system shall include the following:
- Engine-driven generator set
 - Control system
 - Cooling system
 - Connection to natural gas system
 - Generator set accessories
 - Mounting system
 - System control and switchgear
 - Base slab and vibration isolation
 - Weatherproof housing, sound attenuated

1.3 RELATED WORK

Refer to the following specifications for related mechanical and electrical considerations:

Section 16000 - Electrical Work
Section 16260 - Automatic Transfer Switch

1.4 SYSTEM DESCRIPTION

- A. The electric power generating system shall have a site capability of xxx kw, xxx kva, under continuous standby operation.
- B. The system shall consist of a natural gas generator set which includes all controls, protection, output circuit breaker, wiring, and accessories for automatic start-stop operation.
- C. The overload capability shall be in excess of this rating, at extreme limits of parameters specified, for not less than 1 hour.

Where air temperature extremes are not the case, test results will be extrapolated. The results shall be as interpreted by the University of Arizona Electrical Engineer.

- D. The generator set shall include the capability of automatically controlling generator set operation. After starting, the unit will attain rated speed and voltage, and accept rated load. Generator set speed shall be controlled by the engine governor, while generating output voltage regulation shall be a function of the generator automatic voltage regulator. Manual adjustment of generator speed and voltage shall be provided.
- E. The generator set start-stop sequence shall be initiated manually or automatically by closing or opening of a contact. The control system shall automatically engage the cranking motor, sense engine starting speed, disengage the motor and arm the engine protection circuit.
- F. The set shall immediately shut down in the event of overspeed, low oil pressure, high water temperature and overcrank. Cause of shutdown shall be indicated by a light annunciator. System logic shall prevent restart until fault is cleared.

There shall be a provision for manual shutdown in the event of an emergency.

1.5 SITE CONDITIONS

The operating environment of the power generating system shall be:

Altitude	2400 ft.
Engine room temperature, max	125 F
Outside temperature, min	20 F
Outside Temperature max	115 F
Fuel type	Natural Gas
Fuel pressure (gas)	Verify pressure for specific site by contacting FDC

1.6 SYSTEM PERFORMANCE, GENERAL

- A. The power generating system shall conform to the following performance criteria:
 - 1 Rating - Engine brake horsepower shall be sufficient to deliver full rated generator set KW/KVA at the installation site when operated at rated rpm and equipped with all engine-mounted parasitic and external loads such as radiator fans and power generators.
 - 2. The Gas engine shall be able to deliver rated power when operating on dry natural gas having a low heating value (LHV) of 905 Btu/cu ft (33.74 kJ/L).
 - 3. Gas Engine fuel rates shall be based on fuel having a low heating value (LHV) of 905 Btu/cu ft. (33.74 kJ/L).
 - 4. Start Time and Load Acceptance - Engines shall start, achieve rated voltage and frequency, and be capable of accepting load within 10 seconds when properly equipped and maintained.
 - 5. Block Load Acceptance - Transient response shall conform to ISO 8528 requirements.

- B. The power generating system shall satisfy the following performance criteria at site conditions:

Total Power Capability	xxx Kw
Frequency	60 Hz
Voltage	480/2771/3 phase 4 wire
Voltage Dip starting Largest Motor sequence	20%
Power Factor	0.8
Overload for 1 Hour	10%

- C. The individual generator set shall exhibit the following performance capability: Caterpillar xxx model. Other manufacturer's are Waukesha, Cummings, Onan, Generc, prior approved. Contact Robert Cousy, P.E., (621-9252) for approval prior to bid due date.

1.7 QUALITY ASSURANCE

- A. The complete power generation system, including engine, generator, and switchgear shall be the product of one manufacturer who has been regularly engaged in the production of complete generating systems for at least 10 years. All components shall have been designed to achieve optimum physical and performance compatibility and prototype tested to prove integrated design capability. The complete system shall have been factory fabricated, assembled, and production tested as performed by Caterpillar, or prior approved systems.

1.8 RESPONSIBILITY

- A. The responsibility for performance to this specification shall not be divided among individual component manufacturers, but must be assumed solely by the primary manufacturer. This includes generating system design, manufacture, test, and having a local supplier responsible for service, parts, and warranty for the total system.

1.9 SUBASSEMBLY AND PACKAGING

- A. Generator set mounted subassemblies such as cooling system, base, air intake system, exhaust outlet fittings, and generator set mounted controls and switchgear shall also be designed, built, and assembled as a complete unit by the engine - generator manufacturer.

1.10 PRODUCTION TESTS

- A. The system manufacturer shall perform post production tests on the generator set supplied. A certified report of these tests shall be available when requested at the time of the generator set order.

1.11 DRAWINGS/SCHEMATICS

- A. All installation drawings and wiring diagrams for the generator set, controls, and switchgear must conform to a common formats of 8 1/2" x 11", 11" x 17" and 24" x 36".

1.12 SUBMITTALS

A. Submittals shall include but not be limited to:

1. Component List - A breakdown of all components and options including switch gear.
2. Technical Data - Manufacturer produced generator set specification or data sheet identifying make and model of engine and generator, and including relevant component design and performance data.

a. Engine:

Type, aspiration, compression ratio, and combustion cycle.
 Bore, stroke, displacement, and number of cylinders.
 Engine lubricating oil capacity.
 Engine coolant capacity without radiator.
 Engine coolant capacity with radiator.
 Coolant pump external resistance (maximum). Where remote radiator is specified

3. Generator: Model
 Model
 Frame
 Insulation class
 Number of Leads
 Weight, total
 Weight, rotor
 Air Flow

At rated voltage:

Efficiency at 0.8 power factor for: 50% load, 75% load, 100% load
 Fault current, 3 phase symmetrical
 Decrement curve

4. Radiator: (High Ambient, Brass)
 Model
 Type
 Coolant capacity, radiator
 Coolant capacity, radiator and engine
 Weight: Dry, Wet

5. System:
 Dimensions: Length, Width, Height
 Weight: Dry, Wet

- Performance in 115°F air, 2400 MSL.

Continuous power rating at 0.8 power factor (KW) kVA rating
 Fuel consumption at standard conditions for:
 50%, 75% and 100% load Heat rejection to:
 coolant, after-cooler, exhaust, atmosphere from engine, and atmosphere

from generator
Exhaust gas stack temperature
Exhaust gas components; % NOX, % SO
Tons particulate/yr/mo at 50%, 100% load
Verification of 10% overload capability

- B. Transient response of frequency and voltage for the generator set:
- C. Auxiliary Equipment - Specification or data sheets, including switchgear, spring type vibration isolators.
- D. Drawings - General dimensions drawings showing overall generator set measurements, mounting location, and interconnect points for load leads, fuel, exhaust, cooling and drain lines.
- E. Wiring Diagrams - Wiring diagrams, schematics and control panel outline drawings published by the manufacturer in Joint Industrial Council (JIC) format for controls and switchgear showing interconnected points and logic diagrams for use by contractor and owner.
- F. Warranty Statements - Warranty verification published by the manufacturer.
- G. Service - Location and description of supplier's parts and service facility including parts inventory and number of qualified generator set service personnel.

1.13 SERVICE AND WARRANTY

- A. The manufacturer shall have a local authorized dealer who can provide factory trained servicemen, the required stock of replacement parts, technical assistance, and warranty administration.
- B. The manufacturer's authorized dealer shall have a parts and service facility within 130 miles of the jobsite.
- C. The generator set supplier shall have factory trained service representatives and tooling necessary to install, test, maintain, and repair all provided equipment.

1.15 WARRANTY ADMINISTRATION

- A. The manufacturer's authorized dealer shall be capable of administering the manufacturer's and dealer's warranty for all components supplied by the selling dealer (who may or may not be the same as the servicing dealer).

1.16 WARRANTY TERMS

- A. The manufacturer's and dealer's standard warranty shall in no event be for a period of less than two (2) years from date of initial start-up of the system and shall include repair parts, labor, reasonable travel expense necessary for repairs at the jobsite, and expendables (lubricating oil, filters, antifreeze, and other service items made unusable by the defect) used during the course of repair. Running hours shall not be a limiting factor for the system warranty by either the manufacturer or servicing dealer. Submittals received without written warranties as specified will be rejected in their entirety.

- B. The manufacturer's and dealer's extended warranty shall in no event be for a period of less than five (5) years from date of initial start-up of the system or 2500 operating hours, whichever comes first. It shall include repair parts, labor, reasonable travel expense necessary for repairs at the jobsite, and expendables (lubricating oil, filters, antifreeze, and other service items made unusable by the defect) used during the course of repair. Applicable deductible costs shall be specified in the manufacturer's warranty. Submittals received without written warranties as specified will be rejected in their entirety.

1.21 WARRANTY NAMEPLATE

- A. A warranty nameplate of not less than 152 mm x 203 mm (6 in x 8 in) must be affixed to the generator set with the following data:

Warranty Period:

Start-up Date:

Termination Date:

Supplier Name:

Supplier Address:

24-Hour Emergency Number:

Preventive maintenance to be performed by:

1.22 MAINTENANCE CONTRACT

- A. The generator set supplier shall offer a maintenance and repair contract which guarantees all support costs of the specified system. It shall include routine and 24 hour emergency access to a factory account manager to expedite emergency repairs. This shall be priced during the bid process as an additive bid item.
- B. The contract shall protect the user from parts and labor price increases, and shall provide a refund of residual funds at any time of user dissatisfaction. Optional payment schedules shall include fixed rate throughout the life of the contract.

1.23 PARTS AVAILABILITY

- A. The generator set supplier shall have sufficient parts inventory to maintain over the counter availability of at least 90% of any normal wear and tear parts. (Bets, hoses, filters, turbines, pumps, safeties, regulators, injectors, gaskets)
- B. The generator set supplier shall guarantee overnight 100% parts from the time an order is entered with the dealer.

1.24 OIL SAMPLING SERVICE

- A. The generator set supplier shall provide a scheduled oil sampling service to monitor engine condition on an ongoing basis. The sampling method shall be of the atomic absorption spectrophotometry method.

Immediate notification of critical results shall be provided to the owner's representative.

PART 2- PRODUCTS**2.1 PRODUCTS**

- A. The following articles and paragraphs are intended to define a power generation system of proven type and design, of current production, and with all components commercially available.
- B. Approved systems, subject to conforming to the Specifications are Caterpillar, Generac and Cummins/Onan.
- C. These products shall be from vendors with factory approval as stocking dealer – distributors with evidence of having supplied and serviced units of equal size and performance for at least 5 years.
- D. Generators shall be designed to provide not less than 110% output, based on specified capacity, for a period of 2 hours at temperature extremes.

2.2 ENGINE

- A. The engine shall be a stationary, liquid cooled, 1800 rpm, four-cycle design, vertical in-line or V-type, with Dry exhaust manifolds. It shall have cylinders with minimum displacement of xx liters and be manufactured in the United States.

2.3 ENGINE EQUIPMENT

- A. The engine shall be equipped with air filters, fuel filters and pressure gauge, lubricating oil cooler, filters, and pressure gauge, water pump and temperature gauge, service hour meter, flywheel, and flywheel housing.

2.4 LUBRICATION SYSTEM

- A. The lubrication oil pump shall be a positive displacement type that is integral with the engine and gear driven from the engine gear train. The system shall incorporate full flow filtration with bypass valve to continue lubrication in the event of filter clogging.
- B. The bypass valve must be integral with the engine filter base or receptacle. Systems where bypass valves are located in the replaceable oil filter are not acceptable. Pistons shall be oil cooled by continuous jet spray to the underside or inside of the crown and piston pin.
- C. System shall utilize synthetic lubricants with compatible filtration, and compatible engine seals, approved by the engine manufacturer.

2.5 GASEOUS FUEL SYSTEM

- A. The gaseous fuel system shall consist of gas pressure regulators and carburetors. The carburetor shall be a diaphragm type which includes a load screw for air-fuel ratio adjustment, and throttle body to control the air-fuel mixture to the engine.

2.6 IGNITION SYSTEM

- A. The ignition system shall be the low tension type and consist of magneto, transformers, and spark plugs. The magneto shall be of solid state design and spark plugs will incorporate gold palladium electrodes for reliability and life.

2.7 GOVERNOR

- A. The engine governor shall control engine speed and transient load response within commercial and ISO 8528 tolerances. It will be selected, installed, and tested by the generator set manufacturer.

2.8 GOVERNOR, ELECTRONIC-SPEED CONTROL

- A. The engine governor shall be a Woodward 2301 Electronic Speed Control with EG Electro-Hydraulic Actuator or Barber Coleman Equal. Speed droop shall be externally adjustable from 0 (isochronous) to 10% from no load to full rated load. Steady state frequency regulation shall be ± 0.25 percent.

2.9 COOLING SYSTEM

- A. The engine jacket water cooling system shall be a closed circuit design with provision for filling, expansion, and de-aeration. The cooling pump shall be driven by the engine. Auxiliary coolant pumps required for heat exchangers or separate circuit after cooling shall also be engine driven. Coolant temperature shall be internally regulated to disconnect external cooling systems until operating temperature is achieved.

2.10 RADIATOR, ENGINE-MOUNTED

- A. Heat rejected to the engine jacket water shall be discharged to the atmosphere through a close coupled radiator. The radiator shall be sized to cool the engine continuously while operating at full rated load and at site conditions of 115°F ambient.

2.11 FAN AND BELT GUARDING

- A. The fan, fan drive, and fan belts shall be covered with punched steel mesh guarding for personnel protection. The guarding shall conform UL 2200.

2.12 BLOWERFAN

- A. The radiator cooling fan shall be a blower type driven from the engine. Air shall be drawn from the engine side and exhausted through the radiator core with no more than 12.7 mm (0.5 in) of water external restriction in addition to core restrictions.

2.13 INLET AIR SYSTEM

- A. The engine air cleaner shall be engine mounted with dry element requiring replacement no more frequently than 250 operating hours or once each year.

2.14 TURBOCHARGING

- A. Only single stage turbo charging shall be allowed.

2.15 AFTERCOOLING

- A. After-cooler core air surfaces shall be coated with a corrosion inhibitor to minimize oxidation.

2.16 EXHAUST SYSTEM

- A. The engine exhaust system shall be installed to discharge combustion gases quickly and silently with minimum restriction. System including silencer shall be designed for minimum restriction, and in no case shall back pressure exceed 6.7 kPa.
- B. Heavy walled piping such as Schedule 40 is preferred, with radii of 90 bends at least 1-1/2 times the pipe diameter. Piping shall be installed with 229 mm (9 in) minimum clearance from combustible material or incorporate appropriate insulation and shielding.
- C. Piping shall be supported and braced to prevent weight or thermal growth being transferred to the engine and flexible expansion fittings provided to accommodate thermal growth. Support dampers and springs shall be included where necessary to isolate vibration. Install in accord with manufacturer's recommendations.
- D. Long runs of pipe shall be pitched away from the engine and water traps installed at the lowest point. Exhaust stacks shall be extended to avoid nuisance fumes and odors. And outlets cut at 45° to minimize noise. Aim outlet to northwest as directed.

2.17 SILENCER-CRITICAL

- A. Provide critical silencer in accordance with Paragraph 2.32 E.
- B. The silencer shall have an end inlet and end outlet.

2.18 PACKAGED SYSTEMS

- A. Submit for individual approval in lieu of Paragraph 2.16.

2.18 ELECTRIC STARTING SYSTEM

- A. The engine starting system shall include 24 volt DC starting motor(s), starter relay, and automatic reset circuit breaker to protect against butt engagement. Batteries shall be maintenance free, lead acid type mounted near the starting motor. A corrosion resistant or coated steel battery rack shall be provided for mounting. Required cables will be furnished and sized to satisfy circuit requirements. The system shall be capable of starting engine within 10 seconds. 12 v systems will be considered for 75 kw or less units by prior approval.

2.19 JACKET WATER HEATER

- A. Jacket water heater(s) shall be provided to maintain coolant temperature of 32 C (90 F) while the engine is idle. Heaters shall accept 208 volt AC single phase power and include adjustable thermostats.

2.20 BATTERIES

- A. Batteries for starting and control shall be selected and supplied by the generator set manufacturer. They shall be a heavy duty SLI lead acid type with through-partition connectors, and housed in a hard rubber or polypropylene case with provision for venting.
- B. Battery warranty shall be the responsibility of the generator set manufacturer.

2.21 ALTERNATOR

- A. An engine mounted belt driven battery charging alternator shall be installed with an automatic voltage regulator. It shall be suitable for heavy duty applications with a rating of 24 volts.

2.22 INSTRUMENTATION-ENGINE

- A. The engine mounted instrument panel shall consist of a shock-mounted formed and welded enclosure primed for coastal environment. Provide Metric/English marked gauges. Gauges shall include: engine oil pressure, oil filter differential, fuel pressure, jacket water temperature, electric service meter and running time meter.

2.23 GENERATOR

- A. The generator shall be equivalent to caterpillar model xxx and shall be rated for Standby service at xxx kw, xxx KVA, 0.8 PF, xxx V, three phase, wire, 60 Hz, 1800 rpm.
- B. The generator shall be capable of withstanding a three phase load of 300% rated current for 10 seconds, and sustaining 150% of continuous load current for 2 minutes with field set for normal rated load excitation.
- C. It shall exhibit less than 5% waveform deviation at no load.
- D. Generator efficiencies shall be calculated according to IEC 34-2 Section 4, with all current squared times R losses corrected to 115 F.

2.24 STRUCTURE

- A. The generator shall be close coupled, drip proof and guarded, constructed to NEMA I and IP 22 standards, single bearing, salient pole, revolving field, synchronous type with amortisseur windings in the pole faces of the rotating field.

2.25 MECHANICAL DESIGN - SINGLE BEARING

- A. The generator housing shall be one piece and mount directly to the engine flywheel housing without bolted adaptors.

2.26 WINDINGS

- A. Thermal Class 200 magnet wire as described by NEMA Magnet Wire Standard MW 1000, Section MW 35-C, shall be used for rotor and stator windings. The windings shall consist of copper magnet wire. All winding insulation materials shall be Class H in

accordance with BS and IEEE standards.

2.27 OPERATING ENVIRONMENT

- A. The generator shall be designed to operate in a sheltered drip-proof environment.

2.28 EXCITER-PERMANENT MAGNET

- A. The permanent magnet excitation system shall derive excitation current from a pilot exciter mounted on the rotor shaft. It shall enable the generator to sustain 300% of rated current for ten seconds during a fault condition.

2.29 VOLTAGE REGULATOR - SEALED

- A. The automatic voltage regulator shall be manufactured by the manufacturer of the engine generator set. The volts/hertz regulator shall sense line-to-line three phases of generator output voltage and exhibit the following characteristics:
1. Generator output voltage maintained within +/- 1% of rated value for any load variation between no load and full load.
 2. Generator output voltage drift no more than +/- 1/2% of rated value at constant temperature.
 3. Generator output voltage drift no more than **+1-** 1% of rated value within a 40° change over ambient temperature range of -40° C to 70° C.
 4. Generator frequency change not over ¼ cycle no load to full load and back.
 5. Response time less than 20 milliseconds.
 6. Telephone Influence Factor (TIF) of less than 50.
 7. Electronic Interference/Radio Frequency Interference (EMI/RFI) suppressed to commercial standards.
 8. The regulator shall include the following features:
 - a. Voltage level rheostat to provide generator output voltage adjustment of -25% to +10% of nominal.
 - b. Gain adjustment to provide output voltage compensation for changes in load or frequency.

2.30 MOUNTING BASE-STANDBY PACKAGE

- A. The base shall be constructed of formed "C" section steel members with minimum 6 mm thickness. Corners shall be squared to provide rodent/bird proof joint when enclosure is added. Provision shall be made for four corner lifting. It shall incorporate flexible fuel lines, external oil and coolant drains and external crankcase fumes disposal hose. Support cross members shall add rigidity and allow installation of vibration isolators between base and generator set. Generous space for ground stub-ups between the

members shall be provided. The base shall include bottom mounting holes.

2.31 ISOLATOR-SPRING TYPE

- A. Steel spring isolators shall be installed between the generator set base and the mounting surface. The isolators shall bolt to the base, and have a waffled or ribbed pad on their bottom surface. The pads shall be resistant to heat and age, and impervious to oil, water, antifreeze, diesel fuel, and cleaning compounds

2.32 ENCLOSURE - STANDBY PACKAGE, FULL

- A. The enclosure shall offer protection as specified by OSHA from all moving and hot parts of the engine, generator and radiator. It shall be constructed to allow full access to the engine for maintenance without exposing personnel to any moving machinery. Radiator and radiator fan assembly shall be totally enclosed with lockable door over the radiator cap. The radiator shall be sized to accommodate any resulting air flow restrictions. Provision shall be made for a duct flange or perforated metal grill to protect the radiator core. Doors shall be the lift off hingeless type with lockable stainless steel security latches.
- B. Louvers shall allow sufficient air flow to allow full load operation of the generator set. The louvers shall be twisted to deflect water and direct noise downward. The enclosure shall satisfy IEC 1P22 requirements for drip proof construction acceptable for outside installation when doors are in place.
- C. The enclosure shall be fitted to the generator set base and isolated from engine vibration. Corners shall be formed and welded to assure strength and rigidity. Sheet metal with minimum thickness of 2.0 mm for enclosure and 1.2 mm for doors shall have no burrs or sharp edges. Inside and outside surfaces shall be finished with a baked high performance enamel. Exposed fasteners shall be minimized with all hardware stainless steel.
- D. Outdoor generator enclosures shall be sage green, Federal standard 595b, 14449.

2.32 CONTROLS, PROTECTION AND MONITORING

- A. The controls, protection and monitoring systems of the generator set and its operation shall be the responsibility of the generator set manufacturer. All subsystem components, interfaces, and logic shall be compatible with engine mounted devices.

2.33 AUTOMATIC START-STOP CONTROL

- A. The control panel shall be shock mounted on the generator and have the capability to face either side or the rear of the generator. The 24 volt DC system shall incorporate energize to run logic and include:
 - 1. Control:
 - a. Generator voltage level rheostat and ammeter/voltmeter phase selector switch shall be mounted on the panel door.

- b. The engine start-stop switch shall be door mounted and include positions for off/reset, manual, automatic and stop.
2. Shutdowns/Annunciation:

The generator set shall shut down and individual red lights shall signal operational faults of high water temperature, low oil pressure, overspeed and overcrank.
3. Monitor:

Monitoring devices shall include AC voltmeter, AC ammeter, ammeter/voltmeter phase select switch, frequency meter, electric hourmeter, oil pressure gauge, and water temperature gauge.
4. Safety Devices:

ISO red emergency stop pushbutton shall be provided, and all controls, annunciation, and monitors labeled with ISO symbols.
5. Cycle Cranking

A cycle crank timer shall provide five 10 second cranking periods separated by 10 second rest periods.
6. Engine Cool Down

A cool down timer shall provide an adjustable 0-30 minute engine running period before shutdown after removal of load set at 15 min.
7. Alarm Module

NFPA-99 requirements for the alarm panel shall be satisfied by a 24 volt DC alarm module mounted in the panel and including red indicating lights and silencable alarm horn to annunciate alarm conditions for high and low coolant temperature, low oil pressure, low DC voltage, and system not in automatic.
8. Battery Charger

The battery charger is to be a solid-state device with adjustable float voltage control. It is to be a constant voltage device with current limit, and it is to include an equalize switch which will allow the battery to be overcharged for maintenance purposes.
9. Overvoltage, Undervoltage and Underfrequency Protection

The controls will include devices to protect against overvoltage, undervoltage, underfrequency and overfrequency output from the generator. This protection must sense voltage and frequency directly and controls which attempt to measure these values by measuring excitation current will not be acceptable.

10. Emergency Stop Switch

The engine controls will be arranged to stop the engine if a remote maintained contact emergency stop switch is depressed. Once the switch has been operated, it should not be possible to start the engine until the stop switch is released. The "Switch Off Normal" indicating lamp on the front of the panel and the remote engine fail alarm must both be activated if the stop switch has been operated.

2.34 CIRCUIT BREAKER-GENERATOR SET MOUNTED

- A. The circuit breaker shall be mounted and connected in a guarded drip-proof enclosure. Cable lugs shall be provided for customer connections.
- B. One molded case electronic circuit breaker, three pole, single-throw, stationary-mounted with manual operating handle, overload and short circuit trips, complete with cable lugs. Overcurrent trip shall be 100% rated and sized to provide enclosed and ambient temperature compensation. The breaker shall be qualified for 600 volt operation and tested in accordance with UL Standard 489, LSI / LSIG. Breaker shall be adjustable to allow for 110% output test.
- C. One shunt trip, 24 volt DC, on circuit breaker wired to terminal board.
- D. Three current transformers, 5 ampere secondaries.
- E. One ground connection point.

2.35 REMOTE ANNUNCIATOR PANEL

- A. NFPA-99 requirements for remote annunciation shall be satisfied by a remote mounted electro-mechanical panel which includes red and yellow indicating lights and silencable alarm horn for low oil pressure shutdown, low coolant temperature alarm, high coolant temperature, shutdown, overcrank, overspeed shutdown, battery charger malfunction (via charger switch), generator on load (via Customer switch). Install where directed by the University.

2.36 AUTOMATIC TRANSFER SWITCH

- A. The automatic transfer switch shall be as specified in the specification.

2.37 WEATHERPROOF SOUND ATTENUATING ENCLOSURE

- A. Enclosure shall be sound attenuating enclosure: the engine-generator set shall be factory enclosed in not less than a 12 gauge steel enclosure constructed with corner posts, uprights and headers. The roof shall aid in the runoff of water and include a drip edge. The enclosure shall be coated with electrostatically applied paint, baked and finished to manufacturers specifications. The enclosure shall be completely lined with not less than 1" thick, UL 94 HF-1 listed, sound deadening material. This material must be of a self extinguishing design. The critical silencer shall be included to further reduce the unit sound level. The overall design must be such that sound level is 75dbA at 7 meters (23 feet) or less.
- B. Exhaust silencer(s) shall be provided of the size as recommended by the manufacturer

and shall be of critical grade to attenuate the sound to the level noted above. It shall be supplied with a flexible, seamless, stainless steel exhaust connection. A rain cap will be supplied to terminate the exhaust pipe. These components must be properly sized to assure operation without excessive back pressure when installed.

PART 3- EXECUTION

3.1 EXECUTION

- A. The following articles and paragraphs are intended to define acceptable procedures and practices of inspecting, installing, and testing the generator set and associated equipment.

3.2 PREDELIVERY INSPECTION

- A. A pre-delivery inspection must be performed by the system manufacturers' local dealer at the dealer's facility to insure no damage occurred in transit and all genset components, controls, and switchgear are included as specified herein.

3.3 PREDELIVERY TESTING

- A. Prior to delivery and acceptance, the generator set shall be tested to show it is free of any defects and will start automatically and carry full load. This testing shall be performed at the facility of the system manufacturer's authorized local dealer.
- B. The testing shall be done on dry type, resistive load banks.
- C. The load banks shall not be dependent on the generator control instruments to read amperage and voltage on each phase. Rather, the test instrumentation will serve as a check of the generator set meters.
- D. Load bank testing shall be done in the presence of the owner's engineer or his appointed representative. After manufacturers approved break-in procedure, sample oil, change oil and performance testing, forward oil test results to U of A Engineer. Testing shall be for a minimum of 1 hour at 80% load, 1 hr. at 100% load, 2 hrs. at 110% load, 1.0 pf. Demonstrate voltage dips and frequency dips with block loading. If breaker trips, record time run at 110°
- E. All consumables necessary for testing shall be furnished by the bidder. Any defects which become evident during the test shall be corrected by the bidder at his own expense prior to shipment to the jobsite.

3.4 SHIPMENT TO JOBSITE

- A. Delivery shall be FOB to the jobsite by the system manufacturer's authorized dealer.

3.5 INSTALLATION

- A. The installation shall be performed in accordance with shop drawings, specifications, and the manufacturer's instructions.

3.6 FIELD QUALITY CONTROL

- A. The complete installation shall be checked for procedural and operational compliance by a representative of the system manufacturer's authorized local dealer. The engine lubricating oil and antifreeze, as recommended by the system manufacturer, shall be provided by the generator set dealer. If switchgear and generator sets are furnished by different manufacturers, technical representatives of both manufacturers' authorized dealers shall verify the installation meets requirements. Any deficiencies shall be noted and corrected by the Contractor.
- B. The system manufacturer's dealer representative shall be present to assist the Contractor during start-up, systems check, adjusting, and site testing required after the installation is complete. Re run the pre delivery test and then test the oil. (Do not change the oil.)

3.7 POST-INSTALLATION TESTING

- A. Following installation, the following tests shall be performed by the system manufacturer's local dealer representative(s) in the presence of the owner's engineer or designated appointee.

3.8 PRESTART CHECKS

- Oil level
- Water level
- Day tank fuel level
- Battery connection and charge condition
- Air start supply pressure (if so equipped)
- Engine to control interconnects
- Engine generator intake/exhaust obstructions
- Removal of all packing materials

3.9 OPERATION

- A. Load - two hours operation at 80% of full load rating. One hour operation at 100% of full load rating and one hour at 110°C. After the first half-hour stabilization period at full load, the following shall be recorded at fifteen minute intervals (starting at time equals "zero"):
 - 1. Voltage, amperage, frequency
 - 2. Fuel pressure, oil pressure and water temperature
 - 3. Exhaust gas temperature at engine exhaust outlet
 - 4. Ambient temperature
- B. If equipped with appropriate instrumentation:
 - 1. Kilowatts
 - 2. Power Factor

3. KVARs
 4. Generator Temperature
- C. Proper operation of controls, engine shutdown, and safety devices shall be demonstrated.

3.10 ORIENTATION

- A. The system manufacturer's authorized dealer shall provide a complete orientation for the owner's engineering and maintenance personnel. Orientation shall include both classroom and hands-on instruction. Topics covered shall include control operation, schematics, wiring and diagrams, meters, indicators, warning lights, shutdown system and routine maintenance.

3.11 SERVICE MANUALS AND PARTS BOOKS

- A. The system manufacturer's authorized local dealer shall furnish one copy each of the manuals and books listed below for each unit under this contract:
1. OPERATING INSTRUCTIONS - with description and illustration of all switchgear controls and indicators and engine and generator controls.
 2. PARTS BOOKS - that illustrate and list all assemblies, subassemblies and components, except standard fastening hardware (nuts, bolts, washers, etc.).
 3. PREVENTATIVE MAINTENANCE INSTRUCTIONS - on the complete system that cover daily, weekly, monthly, biannual, and annual maintenance requirements and include a complete lubrication chart.
 4. ROUTINE TEST PROCEDURES - for all electronic and electrical circuits and for the main AC generator.
 5. TROUBLESHOOTING CHART - covering the complete generator set showing description of trouble, probable cause and suggested remedy.
 6. RECOMMENDED SPARE PARTS LIST - showing all consumables anticipated to be required during routine maintenance and test.
 7. WIRING DIAGRAMS AND SCHEMATICS - showing function of all electrical components.
- B. All manuals and books described above shall be contained in rigid plastic pouches.

3.12 CONTRACT MAINTENANCE

- A. The system manufacturer's authorized dealer shall furnish the owner's engineer with a copy of any contract maintenance agreement negotiated relative to the equipment specified in this section. The contract information shall detail agreed maintenance intervals, work to be performed at each interval, reimbursement schedule for maintenance work, and owner's responsibilities versus dealer's responsibilities.

End of Appendix Section 16620

Section 16621 - AUTOMATIC TRANSFER SWITCH**Part 1 – General**

- 1.01 One 600 Amp, 3 Phase, 480 Volt Automatic Transfer Switch (ATS) shall be provided with gasketed enclosure. The ATS shall consist of an inherently double throw power transfer switch unit and a control module interconnected to provide complete automatic operation. The operating transfer time* in either direction shall not exceed one-sixth (1/6) of a second.
- 1.02 Refer to Specification 16622 for isolation bypass transfer switches.

Part 2 – Products

- 2.01 The transfer switch unit shall be electrically operated and mechanically held. The electrical operator shall be a single-solenoid mechanism, momentarily energized to minimize power consumption and heat generation. The switch shall be positively locked and unaffected by voltage variations or momentary outages so that contact pressure is maintained at a constant value and temperature rise at the contacts is minimized for maximum reliability and operating life. The switch shall be mechanically interlocked to ensure only one of two possible positions – normal or emergency.
- 2.02 All main contacts shall be silver composition.
- 2.03 Inspection of all contacts (movable and stationary) shall be possible from the front of the switch without disassembly of operating linkages and without disconnection of power conductors. A manual operation handle shall permit the operator to stop the contacts at any point throughout the entire travel to properly inspect and service the contacts when required.
- 2.04 A control module shall direct the operation of the transfer switch. The module's sensing and logic shall be controlled by a built-in microprocessor for maximum reliability, minimum maintenance and inherent digital communications capability. The control module shall be connected to the transfer switch by an interconnecting wiring harness. The harness shall include a keyed disconnect plug to enable the control module to be disconnected from the transfer switch for routine maintenance.
- 2.05 The control panel shall meet or exceed the voltage surge withstand capability in accordance with IEEE standard 472-1974 (ANSI C37, 90a-1974) and the impulse withstand voltage test in accordance with the proposed NEMA Standard ICS 1-109.

* Operating transfer time is the time measured from instant of monitored source deviation to closing of main contacts on an available alternate power source exclusive of any purposefully introduced time delay.

2.06 Operation:

- A. The voltage of each phase of the normal source shall be monitored, with pickup adjustable from 85 to 100% and dropout adjustable from 75 to 98% of pickup setting, both in increments of 1%, and shall be fully field-adjustable without the use of any tools, meters or power supplies. Repetitive accuracy of settings shall be +/- 2% or better over an operating temperature range of -20C to -70C. Factory set to pickup at 90% voltage and 95% frequency.

- B. The control module shall include four time delays that are fully adjustable over the entire range as follows:
 - 1. Time delay to override momentary normal source outages to delay all transfer switch and engine starting signals. Adjustable from 0 to 6 seconds. Factory set at 1 second.
 - 2. Transfer to emergency time delay. Adjustable from 0 to 5 minutes. Factory set at 0 minutes unless indicated otherwise on the plans.
 - 3. Retransfer to normal time delay. Time delay is automatically bypassed if emergency source fails and normal source is acceptable. Adjustable from 0 to 30 minutes. Factory set at 10 minutes.
 - 4. Unload running item delay for emergency engine generator cool down. Adjustable from 0 to 60 minutes. Factory set at 15 minutes.
 - 5. Exercising and cool down clocks.
 - 6. All standard features commonly shown in manufacturer's literature.

- 2.07 A set of DPDT gold-flashed contacts rated 10 Amps, 48 VDC shall be provided for a low-voltage engine start signal when the normal source fails. The start signal shall prevent dry cranking of the generator by requiring the generator to reach proper output and to run for the duration of the cool down setting regardless of whether the normal source restores before the load is transferred. Also provide a "commit/no commit to transfer" selector switch to select whether the load should be transferred to the emergency generator if the normal source restores before the generator is ready to accept the load.

- 2.08 A momentary-type test switch shall be provided to simulate a normal source failure. Also, terminals for a remote contact which opens to signal the ATS to transfer to emergency and terminals for remote contacts which open to inhibit transfer to emergency and/or retransfer to normal shall be provided.

- 2.09 Output terminals to signal the actual availability of the normal and emergency sources, as determined by the voltage sensing pickup and dropout settings for each source, shall be provided.

- 2.10 One set of auxiliary contacts shall be provided rated 10 Amps, 480 VAC consisting of one contact closed when the ATS is connected to normal and one contact closed when the ATS is connected to emergency. Also, one set of signal lights to indicated when the ATS is connected to normal source and when the ATS is connected to emergency source shall be provided.

- 2.11 See attached sheet 6 figure #1 for maximum allowable dimensions of ATS without enclosure.

- 2.12
 - 1. For each switch provide trouble shooting hints.
 - 2. For each switch provide O & M manual.
 - 3. For each switch provide complete ladder schematic.
 - 4. For each switch provide wiring diagram.
 - 5. For each switch provide parts list.

2.12 Switching Monitor: Manufacturer shall provide one of the following:

A. Inphase Monitor:

An inphase monitor shall be built-in to the ATS and shall control transfer so that motor load inrush currents do not exceed normal starting currents to avoid nuisance tripping of circuit breakers and possible mechanical damage to motor couplings. The inphase monitor shall operate without external control of electrical loads and without any external control of the power sources. The monitor shall compare the phase relationship and frequency difference between the normal and emergency sources and permit transfer can be accomplished within 60 electrical degrees as determined by monitoring the frequency difference. Inphase transfer shall be accomplished if the sources are within 2 Hz of nominal frequency and 70% or more of nominal voltage.

B. Programmed Monitor:

Monitor shall detect motor decay and provide delayed open transition switching where in phase monitors are provided as part of the software. Provide UofA with codes to activate and deactivate.

2.13 Code Compliance:

The ATS shall conform to the requirements of:

- A. 3 cycle rating in excess of UL 1008 – Standard for Automatic Transfer Switches. (Fully rated.)
- B. UL 1008 – Standard for Automatic Transfer Switches. Optional 3 cycle testing.
- C. NFPA 70 – National Electrical Code including use in emergency and standby systems in accordance with Articles 571, 700, 701 and 702.
- D. NFPA 99 – Essential Electrical Systems for Health Care Facilities.
- E. NFPA 110 – Standard for Emergency and Standby Power Systems.
- F. IEEE Standard 446 – IEEE Recommended Practice for Emergency and Standby Power Systems (Orange Book).
- G. IEEE Standard 241 – IEEE Recommended Practice for Electric Power Systems in commercial buildings (Gray Book).
- H. NEMA Standard ICS – 2-447 – AC Automatic Transfer Switches.
- I. IEC – Standard for Automatic Transfer Switches.
- J. The ATS shall be UL listed in accordance with UL 1008 as follows:
 - 1. Rated in amperes for total system transfer including control of motors, electric-discharge lamps, electric-heating and tungsten-filament lamp loads as referred to in Paragraph 38.13 of UL 1008.

2. Overload and endurance at 480 Volts AC per tables 25.1, 25.2, 27.1 and 27.2 of UL 1008 when enclosed according to Paragraph 1.6.
 3. Temperature rise tests after the overload and endurance tests to confirm the ability of the transfer switches to carry their rated current within the allowable temperature limits.
 4. No welding of contacts. Transfer switch must be electrically operable to alternate source after the withstand current tests.
 5. Dielectric tests at 1960 Volts, RMS, minimum after the withstand current tests.
 6. Additional optional testing for 3 cycle compliance.
- K. The ATS shall be “fully” rated to withstand the RMS symmetrical short circuit current available at the ATS terminals for 3 full cycles, verified by oscillograph testing by an independent test agency, in EXCESS of UL 1008, without series protection of fuses or circuit breakers.

Part 3 Execution

3.01 All production units shall be subjected to the following factory tests:

- A. The complete ATS shall be tested to ensure proper operation of the individual components and correct overall sequence of operation and to ensure that the operating transfer time, voltage, frequency and time delay settings are in compliance with the specification requirements.
- B. The switch shall be subjected to a dielectric strength test per NEMA Standard ICS 1-109.21.
- C. ATS must be monitored by Fire Alarm System and report to the UA fire Safety Shop.

3.02 The manufacturer shall provide a notarized letter certifying compliance with all of the requirements of this specification including compliance with the above codes and standards and withstand current ratings. The certification shall identify by serial number(s) the equipment involved. No exceptions to the specifications other than those stipulated at the time of submittal shall be included in the certification.

3.03 Manufacturer

- A. The ATS manufacturer shall maintain a local service center capable of emergency service or routine preventative maintenance contracts. The manufacturer shall maintain records of each switch by serial number for minimum of 20 years.
- B. The ATS manufacturer shall provide same day emergency parts available to customer.
- C. Whenever the words “AS MAY BE DIRECTED”, “SUITABLE”, “OR EQUIVALENT”, “AS APPROVED”, or other words of similar intent and meaning are used implying that judgment, discretion, or decision is to be exercised, it is understood that it is the

judgment, discretion, or decision of the Owner to which the reference is made. All materials and articles necessary for the work are subject to the approval of the Owner.

DIVISION 16 ELECTRICAL

PROJECT NO.

- D. The following manufacturers are approved, subject to approval, based on conformance to this specification:
- i. Russelectric
 - ii. Others: By prior approval submittal. 3 cycle testing in excess of UL 1008 is required prior to the prior approval submittal.

End of Appendix Section 16621

Section 16622 - *AUTOMATIC TRANSFER SWITCH, ISOLATION BYPASS TYPE

Part 1 – General

- 1.01 Required capacity, (Refer to Contract Drawings), 3 Phase, 480 Volt Isolation Bypass Automatic Transfer Switch (ATS) shall be provided with enclosure. The ATS shall consist of an inherently double throw power transfer switch unit and a control module interconnected to provide complete automatic operation. The operating transfer time* in either direction shall not exceed one-sixth (1/6) of a second.

Part 2 – Products

- 2.01 The transfer switch unit shall be electrically operated and mechanically held. The electrical operator shall be a single-solenoid mechanism, momentarily energized to minimize power consumption and heat generation. The switch shall be positively locked and unaffected by voltage variations or momentary outages so that contact pressure is maintained at a constant value and temperature rise at the contacts is minimized for maximum reliability and operating life. The switch shall be mechanically interlocked to ensure only one of two possible positions – normal or emergency.
- 2.02 All main contacts shall be silver composition.
- 2.03 Inspection of all contacts (movable and stationary) shall be possible from the front of the switch without disassembly of operating linkages and without disconnection of power conductors. A manual operation handle shall permit the operator to stop the contacts at any point throughout the entire travel to properly inspect and service the contacts when required.
- 2.04 A control module shall direct the operation of the transfer switch. The module's sensing and logic shall be controlled by a built-in microprocessor for maximum reliability, minimum maintenance and inherent digital communications capability. The control module shall be connected to the transfer switch by an interconnecting wiring harness. The harness shall include a keyed disconnect plug to enable the control module to be disconnected from the transfer switch for routine maintenance.
- 2.05 The control panel shall meet or exceed the voltage surge withstand capability in accordance with IEEE standard 472-1974 (ANSI C37, 90a-1974) and the impulse withstand voltage test in accordance with the proposed NEMA Standard ICS 1-109.
- 2.06 Operation:
 - A. The voltage of each phase of the normal source shall be monitored, with pickup adjustable from 85 to 100% and dropout adjustable from 75 to 98% of pickup setting, both in increments of 1%, and shall be fully field-adjustable without the use of any tools, meters or power supplies. Repetitive accuracy of settings shall be +/- 2% or better over an operating temperature range of -20C to -70C. Factory set to pickup at 90% voltage and 95% frequency.

* Operating transfer time is the time measured from instant of monitored source deviation to closing of main contacts on an available alternate power source exclusive of any purposefully introduced time delay.

- B. The control module shall include four time delays that are fully adjustable over the entire range as follows:
 - 1. Time delay to override momentary normal source outages to delay all transfer switch and engine starting signals. Adjustable from 0 to 6 seconds. Factory set at 1 second.
 - 2. Transfer to emergency time delay. Adjustable from 0 to 5 minutes. Factory set at 0 minutes unless indicated otherwise on the plans.
 - 3. Retransfer to normal time delay. Time delay is automatically bypassed if emergency source fails and normal source is acceptable. Adjustable from 0 to 30 minutes. Factory set at 10 minutes.
 - 4. Unload running item delay for emergency engine generator cool down. Adjustable from 0 to 60 minutes. Factory set at 15 minutes.

2.07 A set of DPDT gold-flashed contacts rated 10 Amps, 48 VDC shall be provided for a low-voltage engine start signal when the normal source fails. The start signal shall prevent dry cranking of the generator by requiring the generator to reach proper output and to run for the duration of the cool down setting regardless of whether the normal source restores before the load is transferred. Also provide a “commit/no commit to transfer” selector switch to select whether the load should be transferred to the emergency generator if the normal source restores before the generator is ready to accept the load.

2.08 A momentary-type test switch shall be provided to simulate a normal source failure. Also, terminals for a remote contact which opens to signal the ATS to transfer to emergency and terminals for remote contacts which open to inhibit transfer to emergency and/or retransfer to normal shall be provided.

2.09 Output terminals to signal the actual availability of the normal and emergency sources, as determined by the voltage sensing pickup and dropout settings for each source, shall be provided.

2.10 One set of auxiliary contacts shall be provided rated 10 Amps, 480 VAC consisting of one contact closed when the ATS is connected to normal and one contact closed when the ATS is connected to emergency. Also, one set of signal lights to indicated when the ATS is connected to normal source and when the ATS is connected to emergency source shall be provided.

2.11 See attached sheet 6 figure #1 for maximum allowable dimensions of ATS without enclosure.

- 2.12
 - 1. For each switch provide trouble shooting hints.
 - 2. For each switch provide O & M manual.
 - 3. For each switch provide complete ladder schematic.
 - 4. For each switch provide wiring diagram.
 - 5. For each switch provide parts list.

2.12 Switching Monitor: Manufacturer shall provide one of the following:

A. Inphase Monitor:

An inphase monitor shall be built-in to the ATS and shall control transfer so that motor load inrush currents do not exceed normal starting currents to avoid nuisance tripping of circuit breakers and possible mechanical damage to motor couplings. The inphase monitor shall operate without external control of electrical loads and without any external control of the power sources. The monitor shall compare the phase relationship and frequency difference between the normal and emergency sources and permit transfer can be accomplished within 60 electrical degrees as

determined by monitoring the frequency difference. Inphase transfer shall be accomplished if the sources are within 2 Hz of nominal frequency and 70% or more of nominal voltage.

System shall have the ability to be manually switched to a mode that drops the load long enough to allow motor decay and reenergize on the alternate source. This is where the two sources are utilities, or sourced from the same utility.

B. Programmed Monitor:

Monitor shall detect motor decay and provide delayed open transition switching.

2.13 Code Compliance:

The ATS shall conform to the requirements of:

- A. 3 cycle rating in excess of UL 1008 – Standard for Automatic Transfer Switches. (Fully rated.)
- B. NFPA 70 – National Electrical Code including use in emergency and standby systems in accordance with Articles 571, 700, 701 and 702.
- C. NFPA 99 – Essential Electrical Systems for Health Care Facilities.
- D. NFPA 110 – Standard for Emergency and Standby Power Systems.
- E. IEEE Standard 446 – IEEE Recommended Practice for Emergency and Standby Power Systems (Orange Book).
- F. IEEE Standard 241 – IEEE Recommended Practice for Electric Power Systems in commercial buildings (Gray Book).
- G. NEMA Standard ICS – 2-447 – AC Automatic Transfer Switches.
- H. IEC – Standard for Automatic Transfer Switches.
- I. The ATS shall be UL listed in accordance with UL 1008 as follows:
 - 1. Rated in amperes for total system transfer including control of motors, electric-discharge lamps, electric-heating and tungsten-filament lamp loads as referred to in Paragraph 38.13 of UL 1008.
 - 2. Overload and endurance at 480 Volts AC per tables 25.1, 25.2, 27.1 and 27.2 of UL 1008 when enclosed according to Paragraph 1.6.
 - 3. Temperature rise tests after the overload and endurance tests to confirm the ability of the transfer switches to carry their rated current within the allowable temperature limits.
 - 4. No welding of contacts. Transfer switch must be electrically operable to alternate source after the withstand current tests.
 - 5. Dielectric tests at 1960 Volts, RMS, minimum after the withstand current tests.
 - 6. *Additional optional testing for 3 cycle compliance.*

- J. The ATS shall be rated to withstand the fault current noted on the contract drawings single line diagram, at the ATS terminals, for 3 full cycles, verified by ocillograph testing by an independent test agency, in EXCESS of UL 1008 without series protection of fuses or circuit breakers.

Part 3 Execution

3.01 All production units shall be subjected to the following factory tests:

- A. The complete ATS shall be tested to ensure proper operation of the individual components and correct overall sequence of operation and to ensure that the operating transfer time, voltage, frequency and time delay settings are in compliance with the specification requirements.
- B. The switch shall be subjected to a dielectric strength test per NEMA Standard ICS 1-109.21.

3.02 The manufacturer shall provide a notarized letter certifying compliance with all of the requirements of this specification including compliance with the above codes and standards and withstand current ratings. The certification shall identify by serial number(s) the equipment involved. No exceptions to the specifications other than those stipulated at the time of submittal shall be included in the certification.

3.03 Manufacturer

- 5. The ATS manufacturer shall maintain a local service center capable of emergency service or routine preventative maintenance contracts. The manufacturer shall maintain records of each switch by serial number for minimum of 20 years.
- 6. The ATS manufacturer shall provide same day emergency parts available to customer.
- 7. Whenever the words "AS MAY BE DIRECTED", "SUITABLE", "OR EQUIVALENT", "AS APPROVED", or other words of similar intent and meaning are used implying that judgment, discretion, or decision is to be exercised, it is understood that it is the judgment, discretion, or
- 8. Decision of the Owner to which the reference is made. All materials and articles necessary for the work are subject to the approval of the Owner.
- 9. The following manufacturers are approves, subject to approval, based on conformance to this specification:
 - A. Russelectric Bypass Isolation Switch.
 - B. Zenith Bypass Isolation Switch
 - C. Others: By prior approval submittal. 3 cycle testing in excess of UL 1008 is required prior to the submittal.

End of Appendix Section 16622

APPENDIX

SECTION 16720 – FIRE ALARM SYSTEMS

PART 1 - GENERAL

1.1 WORK INCLUDED

- A. The work covered by this section of the specifications includes the furnishing of all labor, equipment, materials, and performance of all operations in connection with the installation of the Fire Alarm System as shown on the drawings and as herein specified.
- B. The work covered by this section of the specifications is to be coordinated with the related work as specified elsewhere under the project specifications.
- C. The intent of this project is to provide a complete, independent fire alarm for this building.
- D. These specifications require a system that exceeds the requirements of the State Fire Code (SFC).

1.2 RELATED WORK

- A. The drawings, general requirements, conditions of the contract, including General and Supplementary Conditions and Division 1 Specification Sections, apply to this section.
- B. The work described in this section has related work with:
 - Section _____ Electrical General Provisions
 - Section _____ Identification
 - Section _____ Electrical Demolition
 - Section _____ Conduit Systems
 - Section _____ Wire and Cable
 - Section _____ Grounding

1.3 SYSTEM DESCRIPTION

- A. Furnish a complete Class A Fire Alarm System as described herein and as shown on the plans; wire, connect, and leave in first class operating condition. Include a Fire Alarm Control Panel, manual pull stations, automatic fire detectors, horns, strobes, combination horn/strobes, annunciator, and remote control devices. Use closed loop initiating device circuits with individual zone supervision, individual indicating appliance circuit supervision, and incoming and standby power supervision.

Provide Style D initiating circuits, Style Z signaling circuits, Style 6 communications circuits, all wiring, connections to devices, outlet boxes, junction boxes, and all other necessary material for a complete operating system.
- B. Allow for loading or editing special instructions and operating sequences in the Fire Alarm Control Panel as required. Provide a system capable of on site programming to accommodate and facilitate expansion, building parameter changes or changes as required by the owner, authorities having jurisdiction and code requirements. Provide storage for all fire alarm system software operations in a non-volatile, programmable memory within the Fire Alarm Control Panel. Loss of primary and secondary power will not erase the instructions stored in memory.
- C. Provide final as built in .dxf file format, sized and scaled for used on 4190 Generalized Computer Center (GCC)

- D. Incorporate in the resident software programming of the system the full ability for selective input/output control functions based on ANDing, ORing, NOTing, timing and special coded operations.
- E. Provide a system that communicates with all initiating and control devices individually on a multiple addressable peripheral network (MAPNET). Annunciate all initiating and control devices individually at the Fire Alarm Control Panel. Include the following annunciation conditions for each point:
- Alarm
 - Trouble
 - Open
 - Short
 - Ground
 - Device Fail or Incorrect Device
- F. Provide a system capable of individually disabling or enabling all addressable devices. Field configure all devices to allow for the addition of devices on a circuit after the initial installation.
- G. Provide a system capable of multi-dropping up to 127 addressable devices from a single pair of wires.
- H. Provide a system capable of having software programming modified and initiating or control devices added or deleted in the field. Systems that require factory reprogramming to add or delete devices are unacceptable.
- I. Provide all necessary software on disk or cd along with any required software keys to allow the University to program changes, additions, removals or re-labels. This includes the programming software for the FACP's and the GCC's.
- J. Provide a system with a completely digital, poll/response protocol communications format. System to use parity data bit error checking routines for address codes and check sum routines for the data transmission protocol to achieve a high degree of communication reliability. Systems that do not utilize full digital transmission protocol (i.e. that may use time pulse width methods to transmit data etc.) are not acceptable.
- K. Provide a system where each addressable device is uniquely identified by an address code entered on the base of each device at time of installation. The use of jumpers to set address will not be acceptable due to the potential of vibration and poor contact.
- L. Provide a system capable of supporting up to 10,000 feet wire length for each initiation circuit loop.
- M. ALARM SEQUENCE
1. The system alarm operation subsequent to the alarm activation of any manual station, automatic detection device, or sprinkler flow switch is to be as follows:
 - a. Sound a continuous fire alarm signal on all audible alarm indicating appliances until silenced by the alarm silence switch at the Fire Alarm Control Panel or the remote annunciator.
 - b. Flash strobes continuously on all visual alarm indicating appliances until System is reset.
 - c. Release all doors normally held open by door control devices.

- d. Send a supervised signal to notify the central monitoring station (UAPD). To accommodate and facilitate job site changes the type of "city connection circuit" is to be on site configurable to provide either a "reverse polarity", "local energy", "shunt" or dry contact connection.
 - e. Activate/deactivate mechanical controls on the air handling systems per specifications of the owner and in accordance with NFPA 101 - Life Safety Code. Sequentially restart air handling units upon system reset to reduce electrical demand.
 - f. Display an alarm condition on the Fire Alarm Control Panel display per 2.3.A of these specifications. Flash the alarm LED on the Fire Alarm Control Panel and the remote annunciator until the alarm has been acknowledged at the Fire Alarm Control Panel or the remote annunciator. Latch the alarm LED on upon alarm acknowledgement. After the alarm has been acknowledged, flash the alarm LED on the Fire Alarm Control Panel and the remote annunciator again upon receipt of a subsequent alarm from another device/zone. Display the new alarm information on the Fire Alarm Control Panel display.
 - g. Provide a pulsing alarm tone that will occur within the Fire Alarm Control Panel and the remote annunciator until acknowledged. Provide a pulsing alarm tone that is capable of being disabled or removed if so specified by the owner.
2. All elevator connections shall be per schematic diagram 16720-D1 at end of this section, below is a sequence of operations for the elevator connections;
 - a. The alarm activation of any elevator lobby smoke detector will cause the elevator cabs to be recalled according to the following sequence:
 1. Recall the elevator cabs to the main egress floor (as indicated by the owner and authority having jurisdiction) upon the activation of an elevator lobby smoke detector on any floor other than the main level of egress.
 2. Recall the elevator cabs to the predetermined (as indicated by the owner and authority having jurisdiction) alternate level of egress upon the activation of the elevator lobby smoke detector on the main egress level.
 - b. The alarm activation of any elevator machine room or hoist way heat detector will cause the shunt trip control to be activated for a thirty, (30,) second period and activate a red indicating light near the controlled breaker.
 - c. The presence of shunt trip control power shall be indicated by a green light installed at the same location as the red light required in 16720, 1.3, M, 2, b.
 - d. The loss of shunt trip control power will cause a supervisory condition to be displayed on the Fire Alarm Control Panel.
 - e. The alarm activation of any elevator machine room or hoist way smoke detector will cause the fireman's hat in the cab to flash.
 - f. The presence of generator power for load shall be reported to the elevator controller.
 3. Provide a manual evacuation switch to operate the systems alarm indicating appliances leaving other control circuits in their normal state.
 4. Override the automatic alarm functions either selectively or throughout the system upon activation of auxiliary bypass keys or bypass groups.

5. Immediately display alarm and trouble conditions on the Fire Alarm Control Panel front alphanumeric display. If more alarms or troubles are in the system the operator may scroll to display new alarms.
6. Provide a system with a list key that will allow the operator to display all alarms, troubles, and supervisory service conditions with the time of occurrence. This shall allow for the determination of not only the most recent alarm but also may indicate the path that the fire is taking.
7. All doors normally held open by door control devices shall release upon AC power failure.
8. Generator Controls and Monitoring. (This applies to each generator installed).
 - a. Provide a control ZAM or Relay IAM connected to the generator controls to cause the generator to start and transfer the emergency load to generator power.
 - b. Provide a control ZAM or Relay IAM connected to the generator controls to cause the generator to emergency stop.
 - c. Provide an IAM connected to the generator controls to monitor if the generator is running.
 - d. Provide an IAM connected to the generator controls to monitor if the generator system has a fault.
9. Main Building Emergency Power Off, (EPO)
 - a. Provide a control ZAM or Relay IAM tie into the main EPO circuit to allow for EPO activation.
 - b. Install a Model #2088-9007 powered by the EPO circuit and wired to be normally energized. Connect an IAM to common normally closed side of the Model #2088-9007 to monitor the presence of EPO control power.

N. SUPERVISION

1. Provide a system with Class 'A' (Style 'D') independently supervised initiating circuits so that a fault in any one zone/device does not affect any other zone/device and so that an alarm activation of any initiation circuit does not prevent the subsequent alarm operation of any other initiation circuit.
2. Provide sprinkler supervisory initiation device circuits for connection of all sprinkler valve tamper switches to perform the Supervisory Service Operation. Wiring methods which affect any fire alarm initiation circuits to perform this function will be deemed unacceptable; i.e.: sprinkler and standpipe tamper switches (N/C contacts) shall NOT be connected to circuits with fire alarm initiation devices (N/O contacts). Label this independent initiation circuit as Supervisory Service and provide differentiation between tamper switch activation and wiring faults.
3. Provide independently supervised and independently fused indicating appliance circuits for horns and strobes. Disarrangement conditions of any of these circuits will not affect the operation of other circuits.
4. Supervise all auxiliary manual controls so that all switches must be returned to the normal automatic position to clear system trouble.

5. Include a discrete Fire Alarm Control Panel readout for each independently supervised circuit to indicate disarrangement conditions per circuit.
6. Supervise the incoming power to the system so that any power failure must be audibly and visually indicated at the Fire Alarm Control Panel. A green "power on" LED shall be displayed continuously while incoming power is present.
7. Supervise the system batteries so that a low battery condition or disconnection of the battery shall be audibly and visually indicated at the Fire Alarm Control Panel.
8. Supervise any system expansion modules for module placement. Should a module become disconnected from the controls, the system trouble indicator must illuminate and audible trouble signal must sound.
9. Supervise wiring to a hardwired (non-serial) remote annunciator for open and ground conditions. Provide a separate annunciator trouble readout that will illuminate an LED and sound an audible trouble signal at the Fire Alarm Control Panel upon the detection of an open or ground condition.
10. Provide independent supervision for opens of the air handling on/off/auto switch control output wiring. Provide a discrete trouble panel readout per output circuit for indication. Provide indication of a common ground trouble on the Fire Alarm Control Panel in the presence of a ground condition of the air handling control output wiring.
11. Supervise all slave module LEDs for burnout or disarrangement. Should a problem occur, the Fire Alarm Control Panel shall display the module and the LED location numbers to facilitate location of that LED.

O. POWER REQUIREMENTS

1. Provide the Fire Alarm Control Panel with 120VAC 20AMP power via a dedicated fused disconnect circuit.
2. Provide the system with sufficient battery capacity to operate the entire system upon loss of normal 120 VAC power in a normal supervisory mode for a period of twenty-four (24) hours with 5 minutes of alarm operation at the end of this period. Automatically transfer the system to the standby batteries upon primary power failure. All battery charging and recharging operations shall be automatic.
3. Provide 24VDC from the Fire Alarm Control Panel to all circuits requiring system operating power. Individually fuse all these circuits at the Fire Alarm Control Panel.

1.4 QUALITY ASSURANCE

- A. Provide each and all items of the Fire Alarm System that are the products of a SINGLE fire alarm system manufacturer under the appropriate category by Underwriters' Laboratories, Inc. (U.L.), and bearing the "UL" label. Provide control equipment that is all listed under UL category UOJZ as a single control unit. Partial listing is NOT acceptable.
- B. Provide each and all items of the Fire Alarm System that are the products of a single manufacturer (independent dealers and/or distributors will NOT be considered) who has engaged in the production of this type of equipment (software driven) for at least 10 years, and has a fully equipped service organization within fifty (50) miles of this installation.

- C. Furnish fire alarm equipment installation supervision from a factory trained and certified manufacturer's representative (independent dealers and/or distributors will NOT be considered) who has been engaged in the installation of this type of equipment (software driven) for at least ten (10) years.
- D. Provide system controls that are UL listed for Power Limited Applications per NEC 760, in addition to the UL-UOJZ requirement mentioned above. Mark all circuits in accordance with 2005 NEC article 760 and these specifications.
- E. Provide transient protection devices on all control equipment to comply with UL864 requirements.
- F. Provide additional transient protection must be provided for each circuit, where fire alarm circuits leave the building. Provide devices that are UL listed under Standard 497B (Isolated Loop Circuit Protectors).

1.5 REFERENCES

- A. Install the complete system in conformance with the applicable sections of NFPA 72, NFPA 71, NFPA 70, Local Code Requirements, and National Electrical Code with particular attention to Article 760 and other standards listed in Section 16010.
- B. Install and configure the entire fire alarm system and integrated system operations in conformance with the State of Arizona Fire Code.

1.6 SUBMITTALS

- A. Submit complete fire alarm layout drawings and equipment cut sheets prior to beginning any construction work on the Fire Alarm System. Depict on the layout drawings all equipment and field devices, routing of wiring, connection information, MAPNET identification number for each device, etc.
- B. Submit fire alarm shop drawings to the State Fire Marshal for approval prior to beginning any construction work on the Fire Alarm System.

1.7 DELIVERY, STORAGE, AND HANDLING

- A. Store all fire alarm equipment (Fire Alarm Control Panel, all peripheral devices, equipment enclosures, etc.) in an environmentally controlled location until required on project site. Store all fire alarm equipment at the project site in an environmentally controlled location until installed.

1.8 WARRANTY

- A. Provide a warranty for the completed fire alarm system wiring and equipment to be free from inherent mechanical, electrical, and software programming defects for a period of two (2) years from the date of the completed and certified test by the Authority Having Jurisdiction.
- B. Provide from the equipment manufacturer to the owner a maintenance contract proposal to provide a minimum of two (2) years of complete annual tests and inspections in compliance with NFPA-72 guidelines.

PART 2 - PRODUCTS

2.1 ACCEPTABLE MANUFACTURERS

- A. Provide panels and peripheral devices that are all the standard product of a single manufacturer, displaying the manufacturer's name on each component. Provide a fire alarm system that is manufactured by SimplexGrinnell, Inc. The catalog numbers specified under this section are those of SimplexGrinnell, Inc. and constitute the type, product quality, material, and desired operating features.

2.2 MATERIALS

A. WIRING

1. The following wiring requirements apply in addition to other wiring requirements found elsewhere in these specifications.
2. Use only wiring type approved by the fire alarm equipment manufacturer.
3. Color Coding for fire alarm wiring is listed below. Use solid color compound or solid color coating on all conductors. Identify with colored tape wire sizes for which colored insulation is not available.

<u>Circuit Type</u>	<u>Color Code</u>	<u>To What</u>	<u>Wire Size</u>
Halon Signal Wiring A/Vs & V/Os	Red / Black	Signal Module	#14
Halon Low Tank Pressure Switch	Orange / Brown	IAM	#14
Halon Tank Discharge Switch	Orange / Brown	IAM	#14
Halon Pull Station	Yellow / Blue	IAM	#14
Halon Abort Switch	Yellow / Blue	IAM	#14
Halon Bell	Red / Black	Signal ZAM	#14
Pre-Action Low Air Pressure	Orange / Brown	IAM	#14
Pre-Action Discharge Switch	Orange / Brown	IAM	#14
Solenoid Wiring	Red / Black	Signal ZAM	#14
Solenoid Disconnect Switch	Red / Black	Coil Module	#14
Water Flow Bell	Red / Black	Signal ZAM	#14
Water Flow Switch	Orange / Brown	IAM	#14
Valve Tamper Switch	Orange / Brown	IAM	#14
Smoke Detector	Mapnet	FACP	#18 T/S/P
Beam Detector	Yel / Blu / Wht / Vio	IAM	#14
Heat Detector	Mapnet	FACP	#18 T/S/P
Flame Detector	Yel / Blu / Wht / Vio	IAM	#14
Hood Suppression Systems	Yellow / Blue	IAM	#14
Cable Smoke Detectors (VESDA)	Yel / Blu / Wht / Vio	IAM	#14
Pull Station	Mapnet	FACP	#18 T/S/P
Duct Detector	Mapnet / Wht / Vio	FACP	#18 T/S/P - #14
ZAM (All types)	Mapnet / Wht / Vio	FACP	#18 T/S/P - #14
IAM	Mapnet	FACP	#18 T/S/P
Relays	White / Violet	Control Point	#14
120VAC Door Holders	White / Phase Color	Control Point	#12
120VAC Dampers	White / Phase Color	Control Point	#12
AHU Contactor / MCC Shutdown	Phase Color / Sw Leg	Relay	#12
AHU VFD Shutdown	Red / Red	Relay	#14 or #12
Audio Visual	Red / Black	Sync Module	#14
Visual Only	Red / Black	Sync Module	#14
Signal Module	Red / Black	Signal Circuit	#14
Ground / Bond	Green	Grounds/Bonds	#14

Mapnet is defined as Power Limited or Non-Power Limited Twisted Shielded #18 Pair Cable.

Phase Color is defined as the primary phase color used to power the controlled device.

Sw Leg is defined as the switch leg color used to power the controlled device.

2.3 EQUIPMENT

A. FIRE ALARM CONTROL PANEL

Where shown on the plans, provide and install the Fire Alarm Control Panel called for in these specifications. Provide a Fire Alarm Control Panel compatible as a pier with a Simplex 4120 pier to pier reporting network, this includes total exchange of all analog, digital, pseudo, and control data.

1. Simplex 4120 Network Control Panel:
 - a. This system shall be used for all fire alarm speaker installations.
 - b. This system shall be used for all fire alarm fire phone installations.
 - c. This system shall be used for all addressable detection installations.
 - d. Panel shall include one, (1,) 4120 Network Communications card with two, (2,) RS-485 Hardwire Media Cards.
 - e. Panel shall include one, (1,) Network TCP/IP bridge card with two, (2,) RS-485 Hardwire Media Cards.
 - f. Panel shall include one, (1,) RS-232 card with two, (2,) open ports.
 - g. Panel shall include two, (2,) Ethernet jacks connected per section 16700.
 - h. Panel shall include one, (1,) FieldServer X-40 interface, mounted next to the panel per schematic diagram 16720-D2 at end of this section, programmed with:
 - i. Simplex 4100 protocol driver.
 - ii. BACnet TCP/IP protocol driver.
 - iii. Five thousand, (5,000) point capacity.
 - iv. All fire alarm panel monitor points including spares.
 - v. All fire alarm panel control points including spares.
 - vi. All fire alarm panel pseudo points that are in use.
 - vii. Fire alarm Network System/Detector Reset point.
 - viii. Fire alarm Network Silence point.
 - ix. Fire alarm Network Priority 2 Reset point.
2. Additional Control Panel Equipment and Capacities:
 - a. Fire alarm panels shall be provided with twenty-five, (25,) percent spare capacity installed on the following components:
 - i. Audio circuits.
 - ii. Visual circuits.
 - iii. Speaker circuits.
 - iv. Fire Phone circuits.
 - v. Addressable Detection points.
 - vi. Hard-wire Detection points.
 - vii. Auxiliary Control circuits.
 - viii. Graphic I/O points.
 - ix. Annunciator Control switches and LEDs.
 - b. Power supplies:
 - i. Shall be sized as necessary to provide all the power required in section 16720-2.3, A, 2.

- ii. And shall provide two, (2,) amps of power for each and every installed Notification Appliance Circuit, Auxiliary Control Circuit, Auxiliary Relay Zone Addressable Module, and Signal Zone Addressable Module.
 - c. Batteries:
 - i. Shall be sized as to provide twenty-four, (24,) hours of standby operation for the load handled by the power supplies.
 - ii. Shall be sized as to provide five, (5,) minutes of alarm for the load handled by the power supplies after twenty-four, (24,) hours of standby operation.
 - iii. The only acceptable batteries are listed here by manufacturer, ampacity and voltage.
 1. Eagle Pitcher:
 - a. 6.2A 12VDC.
 - b. 10A 12VDC.
 - c. 18A 12VDC.
 - d. 33A 12VDC Square case or Long case.
 - e. 50A 6VDC.
 2. Sonnenschei:
 - a. 110A 12VDC.
 3. Auxiliary Bypass Keys

Provide five (5) auxiliary bypass keys on the Fire Alarm Control Panel. Activation of these keys to be password protected. When activated, the normal alarm sequence operations of the programmed devices/control functions will not occur. Upon activation of these keys, a trouble condition will be present on the Fire Alarm Control Panel. Indicate on the Fire Alarm Control Panel one (1) trouble condition for each signal circuit/type of device/control function that is effected by the bypass.

Program the keys to accommodate bypassing the following devices/control functions (in order, from top to bottom):

 - Air Handler Unit Shut Down and Door Holder Release
 - Sprinkler System Water Flow Switches
 - Audible and Visual Signaling Devices
 - Duct Smoke Detectors
 - Elevator Recall
 4. Device Bypass Groups

Provide the Fire Alarm Control Panel with the capability of supporting separate lists of device groups whereby particular groups of devices may be bypassed and the rest of the system will remain active and operate as programmed per normal system operation. Program the groups to operate upon activation of a single point, negating the need to deactivate/reactive each individual device in the group. Provide the following groups of devices:

 - Smoke detectors by floor, in groups as designated by the Owner.
- B. NON-ADDRESSABLE PERIPHERAL DEVICES

1. Audio Visual - 75 candela units - Model #4903-9426

Provide polarized fire alarm horn/strobes that operate with 24VDC. Provide separate wire leads for in/out wiring for each leg of the associated signal (horn or strobe) circuit. Provide integral, synchronized, xenon strobe compatible with ADA requirements for the type of occupancy in which the horn/strobe devices are installed. Provide 8000 peak candela power for each strobe and make adjustable from 1 to 3 flashes per second. Synchronize all visuals to flash simultaneously.

2. Visual Only - 30 candela units - Model #4904-9174

Provide, UL Listed, entirely solid state, visual only indicating appliances comprised of a synchronized xenon flashtube, compatible with ADA requirements for the occupancy in which the devices are installed. Synchronize all visuals to flash simultaneously.

3. Speaker Visual – 75 candela units – Model #4903-9357

Provide polarized fire alarm speaker/strobe that operate with 24VDC. Provide separate wire leads for in/out wiring for each leg of the associated signal (speaker or strobe) circuit. Provide integral, synchronized, xenon strobe compatible with ADA requirements for the type of occupancy in which the speaker/strobe devices are installed. Provide 8000 peak candela power for each strobe and make adjustable from 1 to 3 flashes per second. Synchronize all visuals to flash simultaneously.

4. Sprinkler System Water flow switches - Equipment from Division 15 or existing

Monitor automatic sprinkler system water flow switches with Individual Adaptor Modules (IAMs). Provide water flow switches consisting of a cast aluminum pipe saddle housing an electromechanical device to which is attached a corrosion-free, flexible, low-density polyethylene paddle. The paddle conforms to the inside diameter of the sprinkler pipe and senses all water movements. To prevent false alarms, incorporate an adjustable time delay mechanism in the flow switch between the paddle-operated stem and the alarm initiating contacts. Provide a tapped 1/2" conduit connection. Provide a flow switch with a UL listing for the intended purpose.

5. Sprinkler System Valve Tamper Switches - Equipment from Division 15 or existing

Monitor automatic sprinkler system valve tamper switches with Individual Adaptor Modules (IAMs). Provide valve tamper switches consisting of an acid treated, cast aluminum housing with nickel plated parts to resist corrosion. Supervise the removal of the switch housing cover. Provide the switch with either one or two sets of S.P/D.T. micro switches as required. Provide a switch with a UL listing for its intended purpose.

6. Door Holders - 120VAC - Model #2088-9607 (Flush), #2088-9609 (Surface) or Model #2088-9608 (Semi-flush)

Control door holders with Zone Adaptor Modules (ZAMs). Provide magnetic door holders with an approximate holding force of 35 lbs. Provide the door portion with a stainless steel pivotal mounted armature with shock absorbing nylon bearing. Provide a door holder unit capable of being either surface, flush, semi-flush or floor mounted as required. Provide door holders with a UL listing for their intended purpose.

7. Photoelectric Projected Beam Detectors - Transmitter/Receiver Set - Model #D296

Provide photoelectric, projected beam detectors capable of being monitored by Individual Adaptor Modules (IAMs) or Zone Adaptor Modules (ZAMs). Provide photoelectric projected beam detectors with the UL #268 listing. Provide separate

transmitters/receivers capable of long range coverage of up to 328 ft (100M), and have seven (7) sensitivity settings. Incorporate automatic compensation for lens contamination. Include a normal status indicator (Green Pulsing LED), an alarm indicator (Red LED) and a trouble indicator (Amber LED) on the detector. Provide dedicated, resettable, operating power for the detectors from the Fire Alarm Control Panel. Provide 24VDC operating voltage (Nominal).

8. Fire Alarm Auxiliary Relay - Part #2088-9007

Provide one or two single pole, double throw relay switches for loads up to 120VAC. Provide a separate 24 VDC output relay with 10A, 120VAC rated contacts with a 7A in-line fuse for control of each type of equipment indicated to have relays. Provide power to this relay from the 24VDC power for the fire alarm device that controls the relay. Control this relay from duct detector auxiliary contacts or ZAM contacts.

Provide relays for interfacing the fire alarm system with the following equipment:

- air handling system motor control centers
- door holder circuits
- shunt trip circuits

Locate relays in a separate electrical outlet box (4 11/16" square x 2 1/8" deep) adjacent to the equipment/circuit served by the relay. Route circuits from controlled equipment and fire alarm device (duct detector or ZAM) into relay box. Orient relay so any 120VAC (or greater) circuit does not cross the 24VDC fire alarm circuit inside the relay box. Route ONLY 24VDC into the fire alarm device boxes.

D. ADDRESSABLE DEVICE TYPES

1. General - The system Fire Alarm Control Panel, over its two wire multi-drop channel, must be capable of communicating with the types of addressable devices specified below.

2. Addressable Sensor Bases - Model #4098-9792

Provide sensor bases containing an integral LED that will flash each time it is scanned by the Fire Alarm Control Panel (once every 4 seconds). Turn the sensor base LED "ON" when the Fire Alarm Control Panel determines that a sensor is in the alarm or a trouble condition. Sensor bases which do not provide a visible indication of an abnormal condition at the sensor location are not acceptable.

3. TrueAlarm Smoke Sensors - Model #4098-9714

Provide photoelectric type, addressable smoke sensors that communicate actual smoke chamber values to the system Fire Alarm Control Panel. Provide solid state, photoelectric type sensors containing no radioactive material. Use a pulsed infrared LED light source and be sealed against rear air flow entry for sensor operation.

Interrupt the supervisory current of the fire alarm detection loop upon removal of the detector head and cause a trouble signal at the Fire Alarm Control Panel. Provide a plug-in sensor unit which mounts to a twist-lock base.

Provide sensors with a UL #268 listing and documented as compatible with the control equipment to which they are connected. Provide sensors listed for both ceiling and wall mount applications. Provide sensors containing a magnetically actuated test switch to provide for easy alarm testing at the sensor location.

Scan each sensor by the Fire Alarm Control Panel for its type identification to prevent inadvertent substitution of another sensor type. Permit continued operation of the Fire Alarm Control Panel but initiate a "WRONG DEVICE" trouble condition until the proper type is installed or the programmed sensor type is changed.

Provide sensors with electronics immune to false alarms caused by EMI and RFI.

Provide sensors that fit into a base that is common with both the heat detector and photoelectric type detector and non-addressable bases capable of being monitored by an Zone Adaptor Module (ZAM) or Individual Addressable Module (IAM). Provide sensors compatible with other addressable detectors, addressable manual stations, and addressable Zone Adaptor Modules on the same circuit.

There will be no limit to the number of detectors, stations, or Zone Adaptor Modules, which may be activated or "in alarm" simultaneously.

4. Addressable Thermal Detector Head - Model #4090-9733

Provide UL listed, combination rate-of-rise and fixed temperature (135 F) type, automatically restorable thermal sensing heads.

Interrupt the supervisory current of the fire alarm detection loop upon removal of the heat sensor head and cause a trouble signal at the Fire Alarm Control Panel.

Provide a plug-in heat sensor unit which mounts to a twist-lock base. Provide sensors listed for both ceiling and wall mount applications.

Provide heat sensor units with a UL #268 listing and documented as compatible with the control equipment to which they are connected.

Scan each sensor by the Fire Alarm Control Panel for its type identification to prevent inadvertent substitution of another sensor type. Permit continued operation of the Fire Alarm Control Panel but initiate a "WRONG DEVICE" trouble condition until the proper type is installed or the programmed sensor type is changed.

Provide sensors with electronics immune to false alarms caused by EMI and RFI.

5. Addressable Pull Stations - Model #4099-9003

Provide double action, push-pull type, addressable pull stations containing electronics that communicate the station's status (alarm, normal) to the Fire Alarm Control Panel over two wires which also provide power to the pull station. Set the address for the device on the station itself. Provide pull stations manufactured from high impact red Lexan with raised lettering painted white with a UL listing for the devices intended purpose.

Provide pull stations with a "front" that is hinged to a back plate assembly that will mechanically latch upon operation and remain so until manually reset by opening with a key common to all pull stations. Provide pull stations with the Simplex Series "B" key locksets. Stations which use allen wrenches or special tools to reset are NOT acceptable.

Provide an addressable pull station capable of field programming its "address" location on an addressable signaling line circuit.

There will be no limit to the number of stations which may be activated or "in alarm" simultaneously.

6. Addressable Photoelectric Duct Detector - Model #4098-9756 (uses TrueAlarm Smoke Sensor Model #4098-9714), Remote Test Switch Model #2098-9806 and Sample Tube Kit Model #2098-9799.

Provide solid state, non-polarized, 24VDC, photoelectric type duct detector compatible with the Fire Alarm Control Panel that obtains its operating power from the supervisory current in the fire alarm detection loop.

Provide duct detectors that operate on the light scattering, photodiode principle. Provide an insect screen to minimize nuisance alarms. Provide duct detectors designed to ignore invisible particles or smoke densities that are below the factory set point. Provide duct detectors with sensor heads that are directly interchangeable with an ionization detector type. The 24VDC detector may be reset by actuating the Fire Alarm Control Panel reset switch.

Provide duct detectors with a mounting base with a twist-lock detecting head that is lockable. The locking feature must be field removable when not required. Provide contacts between the base and head of the bifurcated type utilizing spring type, self-wiping contacts. Interrupt the supervisory current of the fire alarm detection loop upon removal of the detector head and cause a trouble signal at the Fire Alarm Control Panel. Provide compatibility of the detector design with other normally open fire alarm detection loop devices (heat detectors, pull stations, etc.).

Provide duct detector housings capable of being alarmed by using a test switch.

Provide duct detector housings that provide access through the front cover for cleaning the detector sampling tubes.

Employ voltage and RF suppression techniques to minimize false alarms.

Install, where indicated on the plans, remote LED alarm indicators and key operated test stations. Locate test stations along foot traffic routes within the space in which the duct detector is located and mount where accessible without the use of a ladder.

7. Individual Adaptor Module (IAM) - Model #4090-9001

Use Individual Adaptor Modules for monitoring water flow switches, valve tamper switches and (if called for) non-addressable detectors.

Use IAMs for conventional 2-wire detection devices and/or contact devices monitored with Style D monitoring. These IAMs will monitor and communicate the device/zone's status (normal, alarm, trouble) to the Fire Alarm Control Panel.

Uniquely identify IAMs at the Fire Alarm Control Panel. Transmit device identification to the Fire Alarm Control Panel for processing according to the program instructions. Should an IAM become non-operational, tampered with, or removed, a discrete trouble signal, unique to the device, shall be transmitted to, and annunciated at, the Fire Alarm Control Panel.

Provide the capability of programming IAMs for their "address" location on the addressable device signaling line circuit. IAMs are to be compatible with addressable manual stations and addressable detectors on the same addressable circuit.

Supervise the IAM for all trouble conditions. Indicate the type of trouble condition (open, short, device missing/failed) at the Fire Alarm Control Panel. Should an IAM fail, it will not hinder the operation of other system devices.

8. Relay Zone Adaptor Module (ZAM) – Model #2190-9163

Use ZAMs for control of door hold opens, elevator functions during alarm conditions, control of air handling unit systems. Provide an addressable interface module for interfacing normally open, direct contact devices to an addressable signaling line circuit. Provide ZAMs capable of mounting in an outlet box (4 11/16" square x 2 1/8" deep). Include cover plates for ZAMs to allow surface or flush mounting. Provide 24VDC power to a ZAM from a separate two wire pair running from an appropriate power supply.

Provide ZAMs with two, easily replaceable, 2 amp fuses, one on each common leg of the relay. Provide each module with Style Z version wiring supervision, looping the wiring back and connecting to the module to allow continual operation of the controlled devices even if the wiring sustains a single break. These ZAMs will communicate the supervised wiring status (normal, trouble) to the Fire Alarm Control Panel and will receive a command to transfer the relay from the Fire Alarm Control Panel.

Uniquely identify ZAMs at the Fire Alarm Control Panel. Transmit device identification to the Fire Alarm Control Panel for processing according to the program instructions. Should the ZAM become non-operational, tampered with, or removed, transmit a discrete trouble signal, unique to the device, to the Fire Alarm Control Panel.

Provide the capability to program the ZAMs for their "address" location on the addressable device signaling line circuit. Provide ZAMs compatible with addressable manual stations and addressable detectors on the same addressable circuit.

Supervise the ZAM for all trouble conditions. Indicate at the Fire Alarm Control Panel the type of trouble condition (open, short, device missing/failed). Should a ZAM fail, it will not hinder the operation of other system devices.

9. Audio Visual - 75 candela units – Model #4903-9451
(Requires Model #4009-9401 and Model #4009-9812)

Provide polarized fire alarm audio visual that operate with 24VDC. Provide separate wire leads for in/out wiring for each leg of the associated signal (audio visual) circuit. Provide integral, synchronized, xenon strobe compatible with ADA requirements for the type of occupancy in which the audio visual devices are installed. Provide 8000 peak candela power for each audio visual and make adjustable from 1 to 3 flashes per second. Synchronize all visuals to flash simultaneously. Transmit device identification to the Fire Alarm Control Panel for processing according to the program instructions. Should the Audio Visual become non-operational, tampered with, or removed, transmit a discrete trouble signal, unique to the device, to the Fire Alarm Control Panel.

10. Visual Only - 75 candela units – Model #4904-9351
(Requires Model #4009-9401 and Model #4009-9812)

Provide, UL Listed, entirely sold state, visual only indicating appliances comprised of a synchronized xenon flashtube, compatible with ADA requirements for the occupancy in which the devices are installed. Synchronize all visuals to flash simultaneously. Transmit device identification to the Fire Alarm Control Panel for processing according to the program instructions. Should the Visual Only become non-operational, tampered with, or removed, transmit a discrete trouble signal, unique to the device, to the Fire Alarm Control Panel.

11. Speaker Visual – 75 candela units – Model #4903-9357
(Requires Model #4009-9401 and Model #4009-9812)

Provide polarized fire alarm speaker visuals that operate with 24VDC. Provide separate wire leads for in/out wiring for each leg of the associated signal (speaker or visual) circuit. Provide integral, synchronized, xenon strobe compatible with ADA requirements for the type of occupancy in which the speaker visual devices are installed. Provide 8000 peak candela power for each speaker visual and make adjustable from 1 to 3 flashes per second. Synchronize all visuals to flash simultaneously. Transmit device identification to the Fire Alarm Control Panel for processing according to the program instructions. Should the Speaker Visual become non-operational, tampered with, or removed, transmit a discrete trouble signal, unique to the device, to the Fire Alarm Control Panel.

E. EQUIPMENT ENCLOSURES

Provide cabinet(s) of sufficient size to accommodate the following equipment:

- Fire Alarm Control Panels
- Fire Alarm Control Panel associated electronic components
- Remote Annunciators

Provide doors, with locks and MEDECO cylinders, for all cabinets. Provide cabinet covers (inside cabinet doors) for all cabinets.

For the Fire Alarm Control Panel cabinet, provide openings in the cabinet cover necessary to manipulate/access all the Fire Alarm Control Panel controls and a transparent door panel to allow freedom from tampering and full view of the various lights and controls. For all other cabinets, provide covered openings in the cabinet cover (for potential future modifications) and solid doors.

PART 3 - EXECUTION

3.1 INSTALLATION

- A. Provide and install the system in accordance with the plans and specifications, all applicable codes and the manufacturer's recommendations.
- B. Install all wiring in strict compliance with all the provisions of NEC - Article 760 A and C, Power-Limited Fire Protective Signaling Circuits or if required may be reclassified as non-power limited and wired in accordance with NEC-Article 760 A and B. Upon completion, the contractor shall so certify in writing to the Owner. Adhere to all other applicable NEC wiring methods.
- C. Install wiring that is approved by the fire alarm equipment manufacturer.
- D. Install Class A (Style 6 Signaling Line Circuit as defined by NFPA-72) communications.
- E. Install all Class A circuits such that the outgoing and return conductors, exiting from and returning to the control unit respectively, are routed separately. Do not run the outgoing and return circuit conductors in the same cable assembly (multiconductor cable), enclosure or raceway. Separate the field outgoing and return wiring by at least 6 feet or by 1-hour fire rated construction. Outgoing and return wiring does not have to be separated where:
 - 1. The circuit is installed underground
 - 2. The circuit encased in 2 hour fire resistive construction
 - 3. The circuit makes a single drop to an individual device within 10 feet of the loop

Exceptions to the 6 foot/1-hour fire rated construction separation of outgoing and returning conductors will be considered by the Owner in unique device location circumstances. Request exceptions to this requirement in writing to the Owner.

- F. Individually configure circuits on site to provide either alarm/trouble operation, alarm only, trouble only, current limited alarm, no alarm, normally closed device monitoring, a non-latching circuit or a alarm verification circuit, to accommodate and facilitate job site changes.
- G. Individually configure horn circuits on site to provide, upon activation, a fast march time, slow march time, temporal code, PNIS code or a master code until silenced upon any output circuit, to accommodate and facilitate job site changes. The PNIS coded pulse on and off time may be selectable on site to provide 16 different duty cycles between 1/4 second and 5 seconds.
- H. Provide separate circuits for the audible and visual portions of all alarm indicating appliances.
- I. Arrange wiring of the circuits for strobe devices such that adjacent strobe devices are on separate circuits. Limit the number of strobe devices on any one circuit to 12 devices.
- J. Provide a manufacturer's authorized representative on-site for supervision of the installation.
- K. Install all devices and fire alarm equipment in accordance with the current NEC, the manufacturer's recommendations, NFPA 72, the plans, these specifications and the requirements outlined below. Notify the Owner if the plans indicate (or field conditions necessitate) locating/positioning any devices contrary to the manufacturer's recommendations, NFPA 72, or the requirements outlined below.
 - 1. Locate smoke detectors as follows:
 - No closer than 3 feet from any air supply diffuser.
 - No farther than 15 feet from a wall or end of a corridor.
 - No farther than 30 feet between detectors.
 - 2. Locate manual pull stations such that the operable portion of the pull station (the center of the handle) located at 48" above the finished floor level.
 - 3. Locate visual only devices such that the device is 80 inches above the finished floor level OR 6" below the finished ceiling level, whichever is lower. Measure height above/below the floor/ceiling to the center of the device.
 - 4. Locate audio/visual devices such that the device is 80 inches above the finished floor level or 6" below the finished ceiling level, whichever is lower. Measure height above floor/below ceiling to the center of the visual component of the device.
 - 5. Locate test switches for duct smoke detectors such that the device is adjacent to a traveled access aisle/path near the air handler served by the test switch and positioned not more than 48" above the finished floor level. Measure height above the floor to the center of the switch.
 - 6. Locate Fire Alarm equipment enclosures such that the center of the display portion of the panel is 60" above the finished floor.
- L. Elevator Interface with Fire Alarm System – to facilitate elevator recall, install smoke detectors at each elevator lobby, in the elevator equipment room, and at the top of the elevator shaft as indicated on the plans. This interface shall be provided regardless of the existing elevator operation. Program the Fire Alarm Control Panel to use these devices to perform the elevator recall function as outlined in Section 1.3.K.2 of these specifications.

Connect the fire alarm system to the elevator controls for elevator recall with ZAMs. Pull three wires (a common, a normally open, and a normally closed) from each elevator recall ZAM into the elevator controls cabinet. If elevator equipment does not facilitate the actual recall function all preparations and installations shall be made to accommodate these functions.

Where there are sprinkler heads in the elevator shaft, elevator pit, or elevator equipment room, install heat detectors, as indicated on the plans, within 2 feet (measured horizontally) of each sprinkler head. For these specific locations, provide heat detectors with a lower temperature rating and higher sensitivity (response time index), as compared to the sprinkler heads.

Provide an auxiliary alarm relay to interlock with the elevator power shut-off/shunt trip unit.

Provide an IAM and a Fire Alarm Auxiliary Relay to monitor the presence of shunt trip power.

Provide a shunt trip circuit breaker on the elevator equipment power circuit in the elevator equipment room. Extend the interlock conductors from the Fire Alarm Control Panel to the new shunt trip circuit breaker.

Provide control ZAM or Relay IAM to activate car fire alarm light if an alarm has been detected in the machine room or hoistway.

M. Air Handler Motor Control Interface with Fire Alarm System

1. Provide a single pole, double throw relay switch for loads up to 120VAC for each air handling unit's motor control center that is equipped with duct smoke detection. Provide a separate 24 VDC output relay with 10A, 120VAC rated contacts with a 7A in-line fuse for control of each type of equipment shown. Provide power to this relay from the 24VDC power to the relay ZAM. Control this relay from the type 2 control ZAM contacts. Locate relays in a separate electrical outlet box (4 11/16" square x 2 1/8" deep) adjacent to the air handling unit motor control center. Route circuits from motor controls and duct detector relay box. Route ONLY 24VDC into the control ZAM box.

N. Door Holder Control

1. Provide ZAMs for the fire alarm system's control of door holders.
2. Provide a double pole, double throw relay capable of switching for loads up to 120VAC for each door holder circuit.
3. Locate relay in a separate electrical box (4" square standard) adjacent to the ZAM box. Route 120VAC circuits from door holders and 24VDC circuit from ZAM into relay box. Orient relay so 120VAC circuit does not cross the 24VDC circuit inside the relay box. Route ONLY 24VDC into the ZAM box.
4. Provide power to relay from the 24VDC power to the ZAM. Provide the output relay with 10A, 120VAC rated contacts with a 7 Amp in-line fuse for control of each door holder circuit. Control this relay from the ZAM contacts.
5. Provide door holder control ZAM with Style Z version wiring supervision, looping the wiring back and connecting to the module to allow continual operation of the controlled devices even if the wiring sustains a single break. Communicate the ZAM's supervised wiring status (normal, trouble) to the Fire Alarm Control Panel and receive commands to transfer the relay from the Fire Alarm Control Panel.

- O. After the completion of the installation, clean all dirt and debris from the inside and the outside of the fire alarm equipment.

3.3 ACCEPTANCE INSPECTION AND TESTING

- A. Perform testing during hours approved by the Owner.

- B. Fully test every function, every device, and the operation of the completed fire alarm system in the presence of the Owner and the equipment manufacturer's representative.
- C. During the testing outlined above, the Owner will direct the contractor and equipment manufacturer's representative as to the Custom Labels to be programmed into the fire alarm system for identification of each device. This process will involve the contractor inspecting and activating each device in the presence of the owner's representative, the manufacturer's representative noting the Custom Label designation as directed by the Owner and programming this information into the Fire Alarm Control Panel.
- D. Certify, in writing, to the Owner that the fire alarm system is fully functional at the completion of the test. In addition to this written certification, provide the owner with a print out and a computer disc of the Fire Alarm Control Panel's programming documentation.
- E. Initiate, upon written approval from the Owner, a 5 calendar day trial period of the fire alarm system under full operational conditions. All functions of the fire alarm system must be operational during this trial period. The system must function for the entire 5 day period without failure, molestation, or operator input (other than that required for normal system operation - such as acknowledging an alarm, silencing and resetting the system, etc).
- F. Should the system not complete this 5 day trial, perform appropriate repairs and retesting in accordance with NFPA 72 and these specifications. Provide a new written certification of the system's operation and revised Fire Alarm Control Panel programming documentation (hard copy and computer disc) to the University. Then initiate, upon written approval from the owner, another 5 day trial. The system must complete a successful 5 day trial before acceptance testing by the Authority Having Jurisdiction will be permitted.
- G. Fully test the system, after the completion of a successful 5 day trial, in the presence of, and as directed by, the Authority Having Jurisdiction/State Fire Marshall's representative and the Owner. Should the system fail this test, make all repairs and upon receipt by the Owner of notification in writing by the contractor of compliance with the required repairs, another 5 day trial period shall be performed.

3.4 LABELING/MARKING

- A. Spray paint red all fire alarm pull and junction boxes and associated covers that will be located in concealed spaces prior to their installation.
- B. Identify the fire alarm system wiring on the pull or junction box cover by printing "FA" with an indelible felt tip pen. Print the identification neatly and legibly.
- C. Maintain wiring color code as indicated in 2.2.A and Section 16127 of these specifications throughout the installation.
- D. Maintain label tags on all wiring at junction points, per these specifications and 1996 NEC Article 760-10.
- E. Mark, with an indelible felt tip pen, the panel box and circuit number on the junction and pull boxes covers of all non-fire alarm wiring connected to the fire alarm system. Print the number of the panel box and circuit number neatly and legibly.
- F. Mark each fire alarm device with its MAPNET circuit and device number as indicated below with an indelible felt tip pen. Print the MAPNET circuit and device number neatly and legibly.
 - Pull stations - On the inside of the pull station face plate, visible when pull station opened with key.
 - ZAMs - On cover of ZAM box. (Include ZAM function, i.e., shunt trip, air handler shut down, etc.)

- IAMs - On the IAM body.
 - Duct Detectors - On the duct detector housing
- G. Mark each fire alarm smoke detector and heat detector with it's MAPNET circuit and device number as indicated below with Kroy (or equal) self adhesive tape with minimum 3/16" high black text. Cover identification text on smoke and heat detectors with Highsmith (or equal) pre-cut, 4 mil, non-glare, self-adhesive vinyl label protectors (item number L97-16140). Locate identification tape on detector base.

3.5 SPARE PARTS

- A. Provide the following quantities of spare parts to the owner upon completion of the project. Provide spare parts in their original factory packaging with all associated installation and product data literature.
1. Horn/Strobes- 10% of installed number or 5 devices (whichever is greater)
 2. Strobes- 10% of installed number or 5 devices (whichever is greater)
 3. Pull Stations- 2 devices
 4. Smoke Sensor Heads- 10% of installed number or 5 devices (whichever is greater)
 5. Heat Detector Heads- 10% of installed number or 5 devices (whichever is greater)
 6. Addressable Bases- 10% of installed number or 5 devices (whichever is greater)
 7. Duct Detector Housings- 1 device
 8. Duct Detector Test Switches- 2 devices
 9. Door Holders- 2 devices
 10. IAMs- 2 devices
 11. ZAMs- 2 devices

LEGEND

- ① PRIMARY FLOOR ZAM MOUNTED ON 4 11/16" BOX. SEE "CONTROL ZAM FOR ELEVATOR SHUNT" DETAIL ON DRAWING EB.08.
- ② ALTERNATE FLOOR ZAM MOUNTED ON 4 11/16" BOX. SEE "CONTROL ZAM FOR ELEVATOR ALT RECALL" DETAIL ON DRAWING EB.08.
- ③ 4 11/16" BOX FOR SHUNT TRIP ZAM AND MONITOR IAM.
- ④ FIRE ALARM SHUNT TRIP ZAM TO ACTIVATE CONTROL RELAY.
- ⑤ FIRE ALARM IAM TO MONITOR POWER STATUS.
- ⑥ 4 11/16" BOX FOR CONTROL AND MONITOR RELAYS.
- ⑦ CONTROL RELAY TO ACTIVATE SHUNT TRIP DEVICE IN ELEVATOR CIRCUIT BREAKER AND LOCAL STATUS LIGHT. SEE "CONTROL ZAM FOR ELEVATOR SHUNT" DETAIL ON DRAWING EB.08.
- ⑧ MONITOR RELAY TO REPORT TO FIRE ALARM SYSTEM. SEE "CONTROL ZAM FOR ELEVATOR SHUNT" DETAIL ON DRAWING EB.08.
- ⑨ 4 11/16" BOX FOR NEON STATUS LIGHTS. GREEN FOR "SHUNT TRIP POWER AVAILABLE" AND RED FOR "ELEVATOR SHUNT TRIP ACTIVATED". MOUNT LIGHTS ON STAINLESS STEEL COVER AND LABEL. IF GREEN LIGHT IS OFF POWER WILL NOT BE AVAILABLE TO OPERATE SHUNT TRIP. IF RED LIGHT IS ON SHUNT TRIP IS ACTIVATED.
- ⑩ SHUNT TRIP CIRCUIT BREAKER. SEE DRAWING ES.02 FOR SIZE.
- ⑪ HAT FLASH ZAM MOUNTED ON 4 11/16" SEE "CONTROL ZAM FOR ELEVATOR SHUNT" DETAIL ON DRAWING EB.08
- ⑫ GENERATED R/VN ZAM MOUNTED ON 4 11/16" SEE "CONTROL ZAM FOR ELEVATOR SHUNT" DETAIL ON DRAWING EB.08

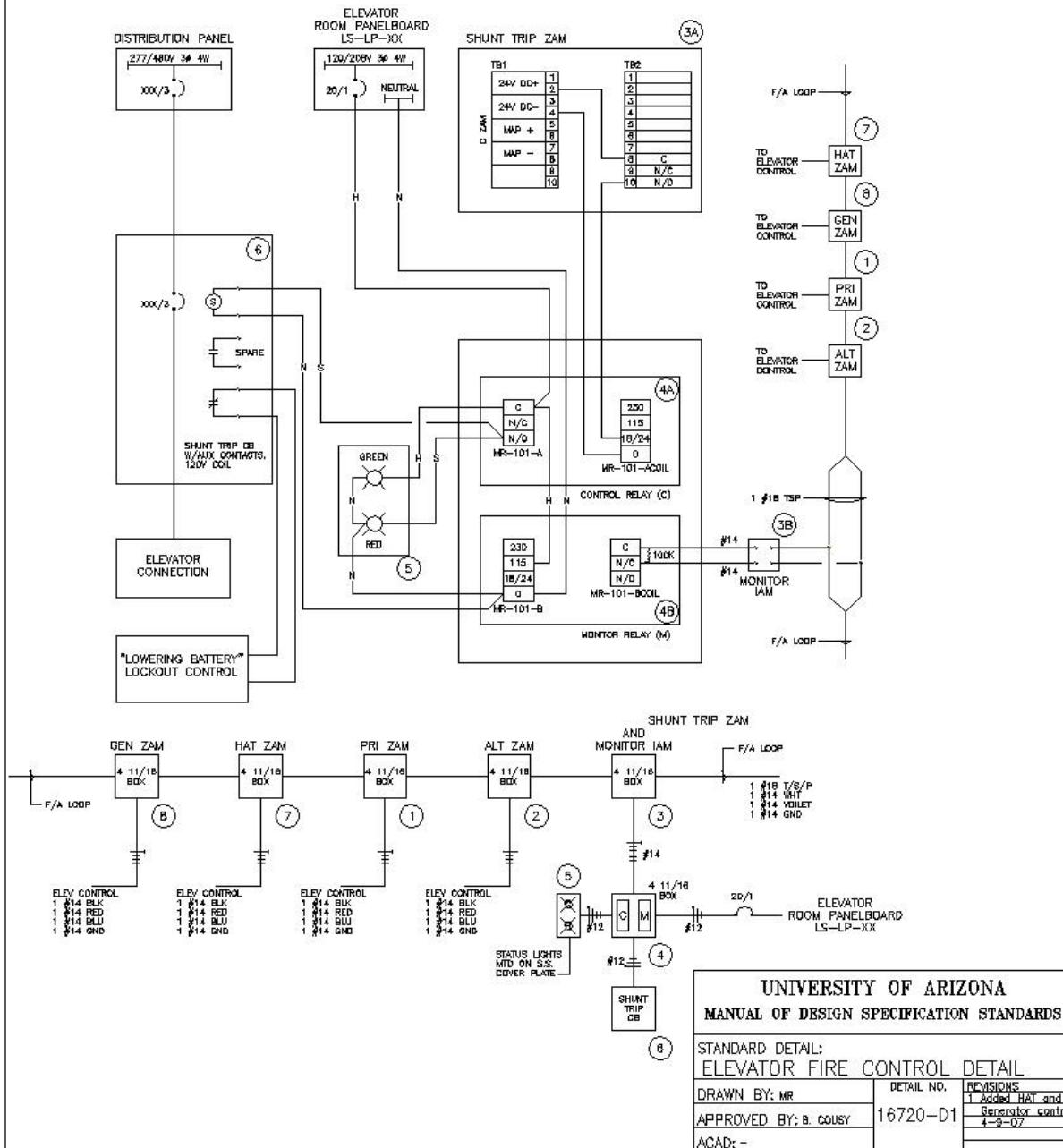

UNIVERSITY OF ARIZONA
MANUAL OF DESIGN SPECIFICATION STANDARDS

STANDARD DETAIL:
ELEVATOR FIRE CONTROL DETAIL

DRAWN BY: MR	DETAIL NO. 16720-D1	REVISIONS
APPROVED BY: B. COUSY		1 Added HAT and Generator control 4-9-07
ACAD: -		

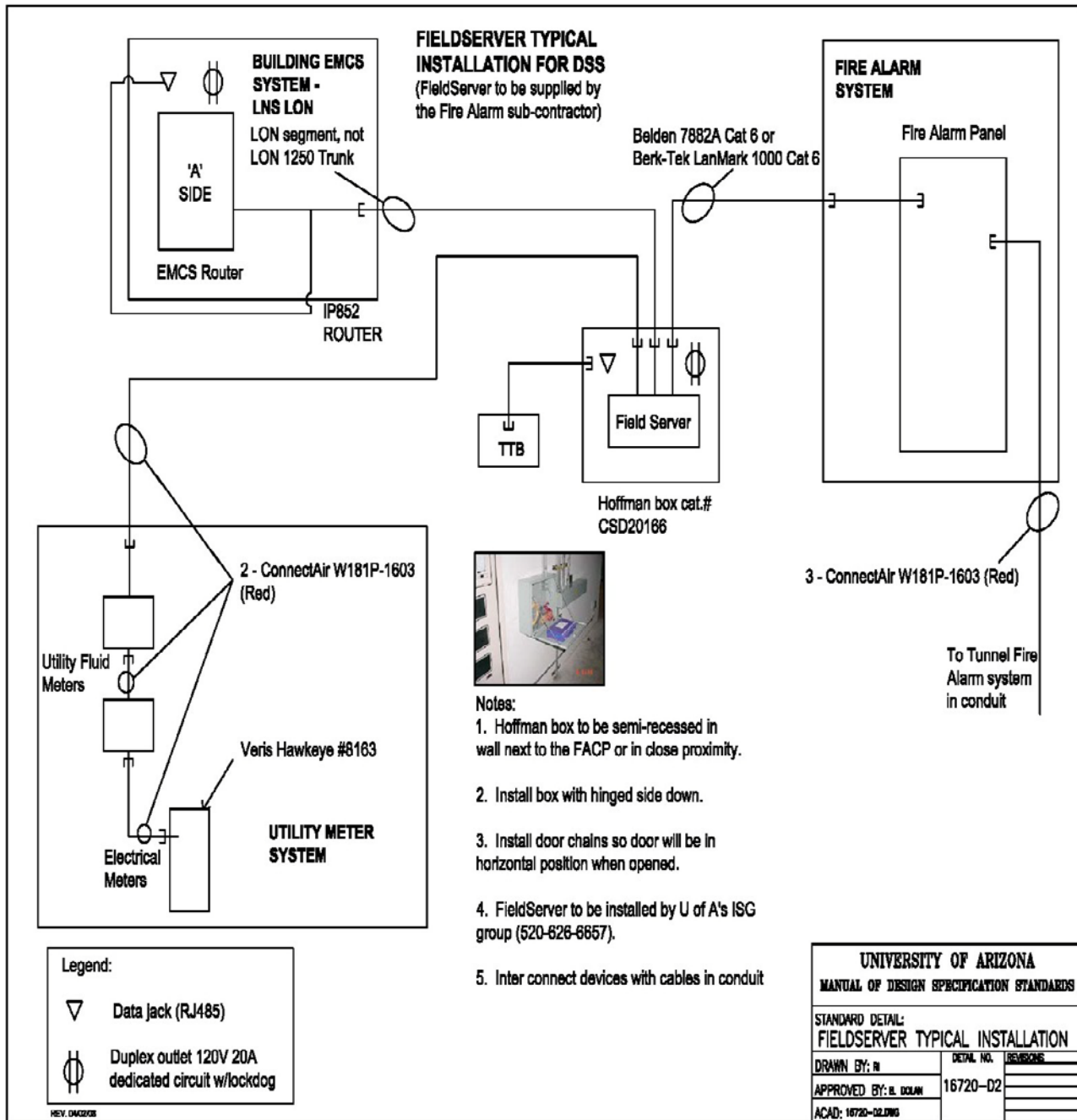

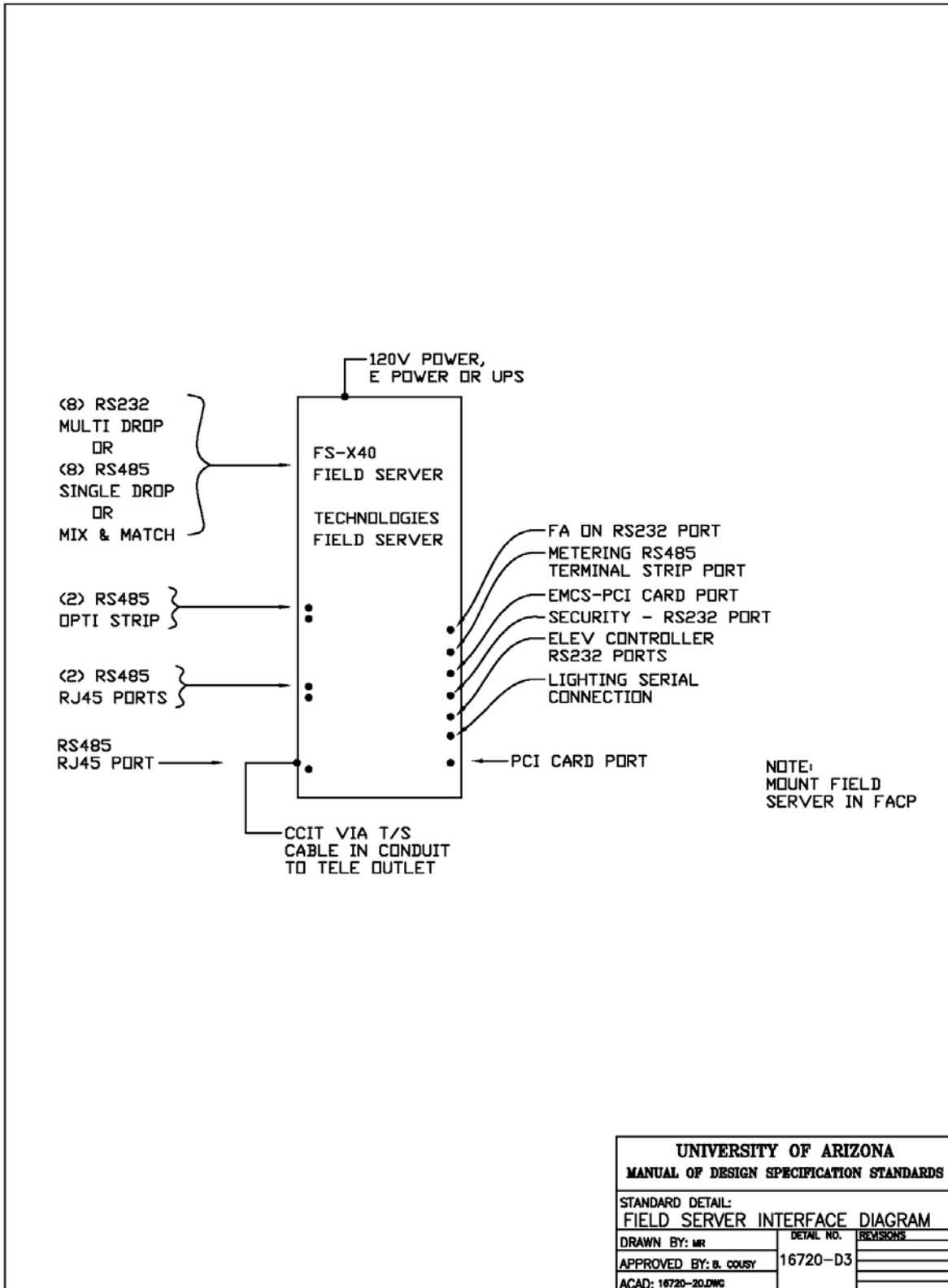

End of Appendix Section 16720