

INTRODUCTION

The purpose of this Manual of Design and Specification Standards (DSS Manual) is to establish and employ a set of baseline standards for the design, construction and maintenance of physical facilities at the University of Arizona. It is intended that these standards represent a holistic balance between affordable, up-front construction costs and long-term, life-cycle costs.

The University typically owns, operates and uses facilities for many years, therefore durability, maintainability and operational efficiencies are crucial. The flexibility to adapt these facilities based on changing needs and paradigms in the future is essential. Just as importantly, the University operates in a competitive market and is largely responsible for funding its own capital development with limited resources. To remain competitive, the University must ensure that its capital development costs are not disproportionate or prohibitive.

The ongoing process to maintain and update the DSS Manual is a multi-stakeholder, multi-department effort led by Brian Dolan, Assistant Director-Construction, Planning, Design & Construction. The technical content of this Manual represents the culmination of input from many individuals and various campus entities who regularly review these standards and integrate current needs and industry practices. Procedures are in place to continuously receive input and issue revisions to the Manual as needed to ensure that it remains relevant and effectively meets the goals of a highly successful University. This revision process is one of the most important components of this living document and is dependent upon the engagement of all interested campus stakeholders.

Recognition is given to all those who participated in the original drafting of this document and to the tireless efforts of those that continue working to keep this document current and highly successful.

Without our collective efforts this Manual would not be possible.



Peter Dourlein, Asst. Vice President
Planning, Design and Construction

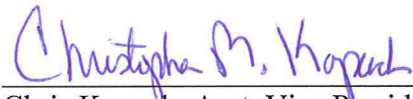

Chris Kopach, Asst. Vice President
Facilities Management



Robert R. Smith, Vice President
Business Affairs

TABLE OF CONTENTS

(Δ = Rev 11/15)
Update #7

INTRODUCTION

REQUEST FOR REVISION FORMS

TAB A TABLE OF CONTENTS

TAB B PROCEDURES

- Δ B-4 International Suite of Codes (New)
- B-9 Record Drawings
- B-10 Variance Procedure
- B-11 Surface Water Procedures

TAB C DESIGN CRITERIA

- C-2 Campus Planning and Urban Design Guidelines
- C-3 Laboratory Planning and Design
- C-5 Custodial Planning and Design
- Δ C-6 Keyless Access and Security System
- C-7 Room Numbering
- C-9 Surface Water Design Guidelines
- C-10 Tree Preservation, Protection, & Salvage Guidelines
- C-11 Indoor Air Quality Criteria
- Δ C-12 Campus Accessibility
- C-13 Campus Sustainability
- Δ C-14 Gender Neutral Restroom Requirements
- Δ C-15 Lactation Room Requirements (New)
- Δ C-16 Use of Sage Green Color On Campus (New)

TAB D BOILERPLATE

DIVISION 00
DIVISION 01

TAB E STANDARDS

DIVISION 02 - SITE WORK

- Section 02100 Demolition
- Section 02200 Earthwork

- Section 02280 Soil Treatment
- Δ Section 02500 Paving and Surfacing
- Section 02610 Site Chilled Water & Heating Water Utilities
- Section 02620 Site Potable Water & Reclaimed Water Utilities
- Section 02640 Site Natural Gas Utility
- Section 02710 Site Sanitary Drainage
- Section 02720 Site Storm Drainage
- Δ Section 02810 Irrigation
- Section 02830 Fences and Gates
- Section 02850 Trash Compactor Embed Plan
- Δ Section 02870 Site and Street Furnishings
- Section 02900 Landscaping
- Section 02910 Temporary Tree and Plant Protection
- Section 02920 Tree Salvage
- Section 02930 Palm Tree Salvage and Planting

DIVISION 03 – CONCRETE

- Δ Section 03310 Structural Concrete
- Section 03330 Architectural Concrete

DIVISION 04 – MASONRY

- Δ Section 04200 Unit Masonry

DIVISION 05 – METALS

- Section 05300 Metal Decking
- Section 05500 Metal Fabrications
- Section 05700 Ornamental Metals- Skateboard Deterrents

DIVISION 06 – WOOD & PLASTICS

- Section 06000 General Discussion
- Δ Section 06100 Rough Carpentry
- Section 06170 Prefabricated Structural Wood
- Section 06200 Finish Carpentry
- Δ Section 06402 Architectural Woodwork

DIVISION 07 – THERMAL & MOSITURE PROTECTION

- Δ Section 07000 General Discussion

- Section 07100 Waterproofing and Dampproofing
- Δ Section 07200 Insulation
 - Section 07240 Exterior Insulation and Finish Systems
 - Section 07250 Fireproofing
- Δ Section 07270 Firestopping
 - Section 07310 Shingles
 - Section 07320 Roofing Tiles
 - Section 07410 Preformed Roof and Wall Panels
- Δ Section 07500 Membrane Roofing
 - Section 07570 Traffic Topping
 - Section 07590 Horizontal Traffic Surfacing
 - Section 07600 Flashing and Sheet Metal
 - Section 07700 Roof Specialties and Accessories
 - Section 07800 Skylights
 - Section 07900 Joint Sealers

DIVISION 08 - DOORS & WINDOWS

- Section 08000 General Discussion
- Δ Section 08110 Steel Doors and Frames
 - Section 08210 Wood Doors
 - Section 08305 Access Doors
 - Section 08330 Overhead Coiling Doors
 - Section 08400 Entrances and Storefronts
 - Section 08500 Metal Windows
 - Section 08610 Wood Windows
- Δ Section 08710 Finish Hardware
 - Section 08711 Finish Hardware; Residence Life
 - Section 08720 Automatic Door Operators
 - Section 08800 Glazing

DIVISION 09 - FINISHES

- Δ Section 09000 General Discussion
- Δ Section 09100 Metal Support Systems
 - Section 09200 Lath and Plaster
- Δ Section 09250 Gypsum Board

- Δ Section 09330 Tile
- Δ Section 09500 Acoustical Treatment
 - Section 09650 Resilient Flooring
- Δ Section 09680 Carpet and Carpet Tile
- Δ Section 09900 Painting
 - Section 09950 Wall Covering

DIVISION 10 - SPECIALTIES

- Section 10000 General Discussion
- Section 10100 Markerboards and Tackboards
- Section 10160 Toilet Compartments
- Section 10260 Wall and Corner Guards
- Section 10293 Bird Control
- Section 10410 Directories and Bulletin Boards
- Δ Section 10420 Dedication Plaque
- Section 10430 Exterior Signs
- Section 10520 Fire Protection Devices
- Δ Section 10810 Toilet Accessories

DIVISION 11 - EQUIPMENT

- Section 11050 Compact Shelving
- Section 11132 Projection Screens

DIVISION 12 - FURNISHINGS

- Section 12000 General Discussion
- Section 12345 Laboratory Casework
- Section 12510 Blinds
- Section 12690 Floor Mats and Frames
- Section 12710 Fixed Seating

DIVISION 14 - CONVEYING SYSTEMS

- Δ Section 14000 General Discussion
- Δ Section 14210 Electric Traction Elevators
- Δ Section 14240 Hydraulic Elevators
- Section 14440 Conveying Systems

DIVISION 15 – MECHANICAL

- Δ Section 15000 General Discussion
- Δ Section 15050 Basic Mechanical Materials and Methods
- Δ Section 15250 Mechanical Insulation
- Δ Section 15300 Fire Protection
- Δ Section 15410 Plumbing Piping
- Δ Section 15440 Plumbing Fixtures
- Δ Section 15450 Plumbing Equipment
- Δ Section 15480 Plumbing Special Systems
- Δ Section 15510 Hydronic Piping and Specialties
- Δ Section 15520 Steam Piping and Specialties
- Section 15530 Refrigerant Piping and Specialties
- Δ Section 15540 HVAC Pumps
- Δ Section 15550 Heat Generation
- Δ Section 15680 Water Chillers
- Δ Section 15780 Packaged Air Conditioners
- Δ Section 15810 Humidifiers
- Δ Section 15840 Ductwork
- Δ Section 15850 Ductwork Accessories
- Δ Section 15855 Air Handling Units With Coils
- Δ Section 15860 Centrifugal Fans
- Δ Section 15870 Variable Frequency Drives
- Δ Section 15970 Control Systems
- Δ Section 15980 Utility Meters
- Δ Section 15990 Testing, Adjusting and Balancing

DIVISION 16 – ELECTRICAL

- Δ Section 16000 General Discussion
- Section 16050 Basic Electrical Materials and Methods
- Δ Section 16110 Raceways
- Δ Section 16115 Underground Distribution
- Δ Section 16120 Wire and Cable
- Section 16122 Primary Power Cables

Δ	Section 16130	Boxes
Δ	Section 16140	Devices
	Section 16160	Cabinets and Enclosures
Δ	Section 16170	Circuit and Motor Starters
Δ	Section 16175	Elevator Power and Controls
Δ	Section 16190	Supporting Devices
Δ	Section 16195	Electrical Identification
Δ	Section 16310	Primary Switching Station
Δ	Section 16320	Transformers (High Voltage)
	Section 16390	Primary Grounding
Δ	Section 16420	Service Entrances
Δ	Section 16425	Motor Control Centers, Controllers and Contractors
Δ	Section 16430	Metering
Δ	Section 16435	Switchboards
Δ	Section 16440	Disconnect Switches
	Section 16450	Secondary Grounding
Δ	Section 16460	Transformers (Low Voltage)
Δ	Section 16465	Busduct
Δ	Section 16470	Panelboards
Δ	Section 16475	Overcurrent Protective Devices
Δ	Section 16485	Lighting Controls and Contactors
Δ	Section 16510	Lighting Design
Δ	Section 16530	Site Lighting
Δ	Section 16535	Emergency Lighting
	Section 16580	Theatrical Lighting
Δ	Section 16610	Uninterruptable Power Supply Systems
Δ	Section 16620	Standby Power Generator Systems
	Section 16622	Automatic Transfer Switch
	Section 16650	Electromagnetic Shielding Systems
Δ	Section 16660	Ground Fault Protection Systems
Δ	Section 16680	Variable Speed Drive Systems
Δ	Section 16700	Telecommunications
	Section 16705	Blue Light Phones

- Δ Section 16720 Fire Alarm Systems
- Section 16730 Clock and Program Systems
- Δ Section 16950 Testing

APPENDIX

ELECTRICAL SUPPLEMENTAL SPECIFICATIONS

- Δ Section 16122 Primary Power Cable
- Δ Section 16310 Primary Switch Station
 - Section 16311 Underground Distribution Switchgear 15kV Class (New)
- Δ Section 16320 Pad Mount Transformer
- Δ Section 16425 Motor Control Centers
- Δ Section 16435 Switchboards
- Δ Section 16620A Diesel Engine Generator Set
- Section 16620B Natural Gas Engine Generator Set
- Section 16621A Automatic Transfer Switch
- Section 16621B Automatic Transfer Switch, Bypass Isolation Type
- Δ Section 16700 Telecommunications (New)
- Δ Section 16720 Fire Alarm Systems

TAB B-4

2012 INTERNATIONAL SUITE OF CODES

The University has adopted the 2012 International Suite of Codes and the 2011 National Electric Code as design criteria for all new construction and renovation projects. This will replace the use of the existing suite of Codes. Amendments to those codes have also been approved. The use of the 2012 suite of codes, the 2011 NEC and amendments is effective immediately and are herein incorporated into the University's Design and Specification Standards. The approved and adopted codes with amendment are as follows:

2012 Edition

- International Fire Code
- International Building Code
- International Mechanical Code
- International Plumbing Code
- International Fuel Gas Code
- International Residential Code

2011 edition

- National Electric code

Amendments

[2011 NEC-UA 28may13.pdf](#)

[2012 IBC-UA -28may13.pdf](#)

[2012 IFC-UA -28may13.pdf](#)

[2012 IFGC-UA -28may13.pdf](#)

[2012 IMC-UA -28may13.pdf](#)

[2012 IPC-UA - 28may13.pdf](#)

[2012 IRC-UA -28may13.pdf](#)

End of TAB B-4

TAB B-9

RECORD DRAWINGS

Project record drawings and shall be prepared for all University of Arizona projects. The concept "Record Drawings" shall replace what has previously been called "As-Builts".

During construction the Contractor shall maintain a clean set of project drawings to record all as-built and record information. This information shall be kept current and in accordance with the requirements of Division 01300. The UA may additionally require that every month, as a condition for progress payment, the Contractor shall print a set of bluelines for review and to insure that the as-builts are being maintained and the updated information is accurate, clear and legible.

At the end of construction the Contractor will give to the Architect/Engineer the updated mylars or the marked up original as-built drawings with each sheet clearly stamped "as-built," signed and dated. The Consultant will then transfer this information to a new set of reproducible mylars. In addition the Consultant will incorporate any other revised information provided during the course of construction. (RFI's, ASI's, RFP's etc.) that may be missing from the Contractor's set of drawings.

Whenever possible changes should be incorporated into the drawings by striking through the original information, entering the new information, referencing the change to the initiating document and flagging/keynoting the revision to "Record Drawings". It is also desirable to include a brief description of the nature of the change when appropriate (i.e., waterproofing added, outlets revised, etc.).

Where the original drawings were produced using AutoCADD the record drawings should also be produced in AutoCADD. Coordinate with UA project manager/facilities project manager for specific formatting requirements of electronic files.

It is realized that Record Drawings produced with AutoCADD will not be sealed as the original construction documents were.

Every drawing sheet shall contain somewhere a large (3/4" x 2") block stating "RECORD DRAWINGS" and the submittal date. In addition, the revision title block listing shall show as its last entry the date of the record drawing submittal and referenced accordingly. The date for every sheet within the complete set shall be the same.

Where contractor furnished shop drawings would be of value for the archival record drawings, they shall be pasted up on a blank title block sheet and/or scanned into an AutoCADD file. Examples of beneficial drawings are fire sprinkler, fire alarm, telecom, EMCS shop drawings and mechanical coordination drawings. These additional sheets can be reduced to facilitate posting on the standard title block sheet. Place a prominent note indicating the origin of the drawing. Create an appropriate sheet numbering scheme and update the drawing index accordingly.

Completed Record Drawing mylars (or paper copies) and electronic drawing files in both Auto CADD and pdf formats are then forwarded to FDC for archiving. A set of drawing copies and/or a copy of the electronic drawing files are sent to FM Engineering for their use and reference.

TAB B-10 VARIANCE PROCEDURE

It is realized that there will be project specific instances where a variance to the specification standards contained with in Tab E of the UA DSS Manual may be desired and/or warranted. Any party to a project may initiate a variance by completing a Request for Variance form and submitting it to the Project Manager for consideration. The process for evaluating the variance item is prescribed by the following flow chart. Variances are only considered on a case by case basis and do not constitute a wholesale revision to the DSS Manual.

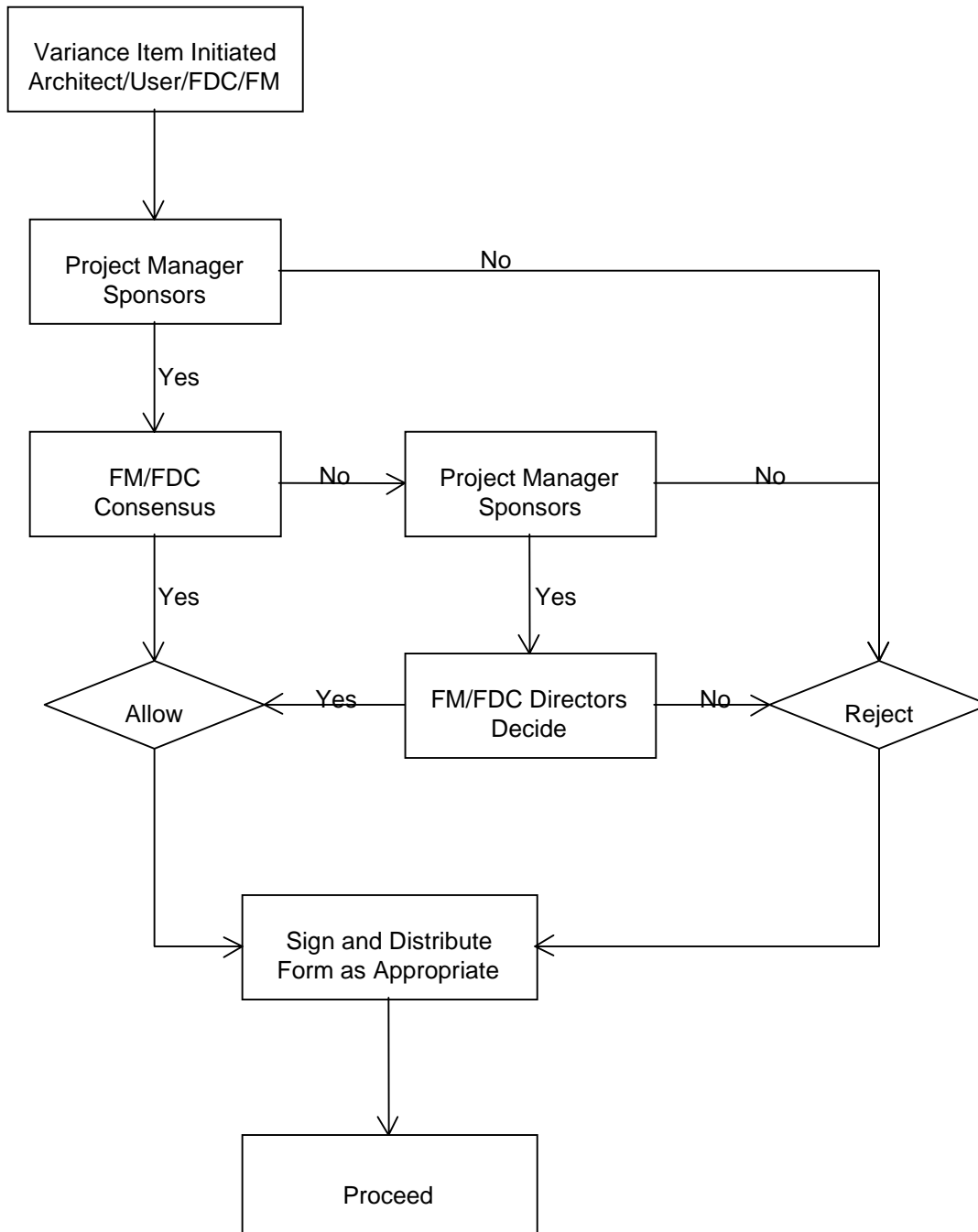

MANUAL OF DESIGN AND SPECIFICATION STANDARDS
REQUEST FOR VARIANCE

Introduction:

The University of Arizona desires to utilize the Design and Specification Standards without exception or variance. Special conditions may arise, however, where a variance is needed or justified. No variance from Design and Specification Standards will be allowed without prior approval indicated on a Request for Variance Form.

Instructions:

1. Complete form in type written text or legible hand printing in black ink.
2. Be sure to include your name, department or firm and telephone number.
3. Provide as much justification for request as possible. Attach additional sheets if necessary and reference them on this form.
4. Please limit requests to one item or subject per form.
5. Deliver or fax completed form to the FDC Project Manager.

Date: _____

From: _____

Telephone: _____
Fax No. : _____

Please consider the following variance from the Manual of Design and Specification Standards.

Project Name: _____ Project No.: _____

Section Number Reference: _____

Variance Requested (attach additional sheets if necessary):

Reason or Justification for Variance (attach additional sheets if necessary): _____

This Request for Variance is _____ Approved _____ Not Approved.

Reasoning: _____

By: _____ Date: _____

Facilities Design and Construction

Distribution: _____

TAB B-11

SURFACE WATER PROCEDURES

1. Prior to Retaining the Design Professional:

Depending on the nature of the project and site, an independent surface water study (as a precursor to the surface Water Report described below) may be required and completed prior to the start of the project for the purpose of understanding site issues, budgeting, or other needs.

2. Project Design Process:

The Design Professional's scope of work will require compliance with the surface water standards found in **TAB-C** and **TAB-E** of this Manual of Design & Specification Standards. As a result of project specific design guidelines identified in the independent surface water study above, surface water requirements may be developed which call for unique surface water features or other special requirements. The *University of Arizona Surface Water Working Group* will be available to review these standards and guidelines with the Design Professional.

The project design should be informed by the most current university comprehensive campus drainage study, project specific site development guidelines, The *University of Arizona Manual of Design and Specification Standards*, site soils tests, and other regulatory considerations. These resources shall guide the preparation of a *Surface Water Report* and design solutions, as required in the project scope of work and described in ~~#3~~ below. The *University of Arizona Surface Water Working Group* is available to the Design Professional throughout the project to discuss and provide guidance on detailed surface water design solutions.

The Design Professional is responsible for insuring that all applicable sub-consultants understand the studies, plan sets, details, and specifications each sub-consultant will need to prepare in order to meet these standards. Sub-consultant fees should appropriately reflect the work necessary to meet these standards.

During the first design stage where site development concepts are being investigated there should be a demonstration of how existing drainage impacts the site along with conceptual options for how surface water may become an integral part of the project design. At each subsequent plan review phase the submittal set shall include designed surface water elements which are responsive to the *Concepts and Mitigation* section of the *Surface Water Report* described below and are developed to a level of design commensurate with the rest of the project.

Appropriate soils tests will be completed as early in the design process as possible to inform the final surface water design solutions. These tests shall include measures needed to understand the suitability of the soil for the infiltration needed for retention/detention, in addition to structural and other characteristics.

3. Surface Water Report

During the first design stage where site development concepts are being investigated, a draft *Surface Water Report* will be prepared by the Design Professional. The report will have two main components: an *Existing Conditions Analysis* section, and a *Concepts and Mitigation* section.

Existing Conditions Analysis: this report section analyzes and documents existing surface water conditions on the project site. The form and methods used for this report should conform in general to City of Tucson standards, e.g., use the format of the City's "Standards Manual for Drainage Design and Floodplain Management in Tucson" to create a Drainage Statement, Hydrology Report, or a Drainage Report. Technical analyses shall be built on the University's most recent Comprehensive Campus Drainage Study hydrology model.

Concepts and Mitigation: each subsequent draft of this report section should include increasing specificity and technical documentation on proposed surface water features and mitigation which emerge

from the initial vision/concepts. This report section shall include, at a minimum, the following two elements:

- Surface water vision and concepts for the project, presented in narrative and graphic form, conveying how surface water may be incorporated in the project design. Evaluation of required, recommended, and anticipated surface water features shall be included, along with topics such as defining finished floor elevations relative to flood levels and evaluating other surface water sources in the vicinity for potential use within the project site. The final Report shall include a water budget for the proposed landscape, including an analysis of water sources available to meet the budget. Proposed concepts and features shall come from a collaborative process involving all applicable team members. At a minimum this should include the project's Landscape Architect, Civil Engineer, and the Project Architect.
- Assessment of anticipated surface water impacts of the project on the surrounding area (the site proper and at least ¼ mile beyond the site limits) and likely mitigation needed. Maps should indicate how the site/project interfaces with its own and adjacent watersheds.

4. Surface Water Report Submittals

Each draft of the *Surface Water Report* will be reviewed by departments represented on the *University of Arizona Surface Water Working Group*. Another copy will be provided to the University of Arizona for transmittal to the City of Tucson stormwater section staff for their review. This is considered a courtesy review, although upon evaluation of City of Tucson comments, the University of Arizona may request such comments be incorporated into the design plans. Following is a summary of each report draft:

- First Draft: The first draft of the *Surface Water Report* shall be included with the project's first concept design submittal. The surface water conditions, concepts, features, and mitigation described within the report are to be included in the presentation to PADRAC. All subsequent PADRAC project presentations and submittal sets shall include these surface water elements developed to a level of design commensurate with the rest of the project.
- Second Draft: A second draft of the *Surface Water Report* shall be due with the schematic design submittal set. This draft shall include updated/refined graphic and narrative descriptions of surface water concepts, features, and mitigation.
- Final Report: The final version of the *Surface Water Report* shall be submitted with the construction document submittal and will include updated modeling and analysis of designed features and mitigation. An executive summary is to be provided which includes, among other information, a statement from the project Civil Engineer noting in both technical and layman's terms ways in which the project design varies from and/or meets City of Tucson standards.

TAB C-2

CAMPUS PLANNING AND URBAN DESIGN GUIDELINES

PROJECT-SPECIFIC

The Department of Planning, Design & Construction (PDC) will provide urban planning input on facility design projects in the following ways:

- Capital Projects
 - PDC will develop Design Guidelines for the project (e.g., massing, circulation, setbacks, etc.) and will review the project for consistency with the Comprehensive Campus plan, and/or any other applicable subarea or functional plans.
- Non-capital Projects
 - PDC will offer design input and interpretation of campus plans to A/E Consultants, but will not prepare Design Guidelines specifically for the project.

GENERAL

- The following guidelines were derived from campus planning documents and briefly summarized guidelines for the development of the campus, particularly where visual quality and urban design issues are concerned. The current Comprehensive Campus Plan (2009) can be viewed at the following link:
http://www.pdc.arizona.edu/resources/documents/UACCP-2009Update_Final_web.pdf
- The goal for campus aesthetics is to:

Establish a sense of aesthetic continuity campus-wide, by developing and utilizing design vocabularies and guidelines in the preservation and reuse of existing structures and open space areas, as well as in the design of new facilities and open spaces.
- It should be noted that visual quality concerns cannot be entirely separated from Development and Infrastructure Guidelines, and that, in fact, both aesthetic and functional considerations are operative in any planning and design activity for the campus. These guidelines primarily focus, however, on the visual quality of the outdoor environment, including buildings and other structures, open spaces, and circulation routes.

BUILDINGS AND FACILITIES

- The guidelines outlined below should be employed in designing new buildings and facilities, and in reuse of and/or additions to existing buildings and facilities.
 - Orientation/Placement of Building On-site
 - The following considerations should be addressed in building siting and design: views, circulation, open space, on-site parking, future expansion, microclimate, and existing site features.
 - Indoor-Outdoor Relationships
 - A more active relationship between interior and exterior space than has occurred in most existing facilities is a goal in the siting and design of new buildings and additions. This relationship is sought not only on the ground plane, but at other building levels as well.

- Scale and Massing
 - New facilities are generally becoming increasingly large and bulky. At the same time, these buildings must be compatible with existing buildings often at a smaller scale, and must be humanly scaled at the pedestrian level(s).
- Architectural Style
 - Within the Historic District, all new construction should be as compatible as possible with existing historic structures. This includes overall massing, fenestration, brickwork, and architectural detailing. The State of Arizona Historic Preservation Office will consult in any reuse of and additions to structures listed on the National Register.
 - In predominantly built-up areas already existing on campus, new construction should be architecturally compatible with the existing structures. While contemporary architectural styling is anticipated, appropriate massing, building materials, and detailing should contribute to a sense of visual unity.
Example: Pharmacy Building
 - In new areas of campus development, (such as between Speedway and Mabel, and Sixth and Eighth Streets), a high standard of contemporary architectural excellence is required. The prevailing desert climate should have a major impact on architectural style.
- Building Materials
 - The selection of exterior building materials for permanent facilities should be based on long-term institutional durability and ease of maintenance; texture and textural variety; color palette; energy conservation considerations; cost and availability; and type and use of structure.
- Artwork and Graphics
 - Works of art should be integrated into the design of each building, especially in building entrance areas (indoor and outdoor) and other high-use common areas. This may include sculpture, murals, architectural relief, and/or pavement patterning.
- Strategic Buildings
 - Gateway buildings anchor strategic street intersections which mark entrances to the campus from public arterial streets. A gateway building functions as a highly visible facility, which structures the aesthetic experience of motorists in the vicinity of the gateway. In addition, the building is key to creating an identifiable campus area for the portion of campus with which it is associated. Particular care should be given to the siting of a gateway building in relation to its intersection, as well as to building design, landscaping, and lighting.
 - Landmark buildings anchor activity nodes or major open space areas. A landmark building is designed to be easily identifiable or visually significant, especially to pedestrians, because of its clear or unique form or massing; high figure - background contrast due to siting, scale, color, or architectural style; and/or its prominent spatial location. Special attention should be given to building design and massing, landscaping, and lighting. New landmark buildings should be designed to actively structure and enhance the usable open space they anchor. *Example: Old Main at Main Mall.*
- Parking Structures and Decks
 - The design guidelines for building and facilities set out above generally apply.
 - Because of the massiveness of parking structures, special consideration should be given to building materials, detailing, and landscaping.

- Safety and security should be a primary design consideration, including the location and visibility of vertical circulation, night lighting, and graphics.

CAMPUS OPEN SPACE

- This section summarizes the guidelines which provide the basis for the design and review of landscaping and open space development plans. This is critical to achieving an overall campus character.
- Overall Character - three typical conditions arise, each calling for a distinct design treatment.
 - For malls and corridor-type open spaces (usually involving street closures), as well as formal campus entrances: Refined, formal arrangement of landscape elements (plantings, seating, lighting, pavement treatment, and so on); characterized by predominantly symmetrical pattern and use of repeated elements. *Existing example: Main Mall. Proposed example: Highland Corridor*
 - For transition zones and campus gateways - informal arrangements of landscape elements, either in continuous meandering pattern for linear conditions, or clustered or grove-like pattern for entry/highlight conditions. *Existing example: Park Avenue Buffer. Proposed example: Speedway Boulevard landscaping treatment*
 - For intensively used plaza areas (activity nodes) - utilization of formal, repeated or patterned elements to identify major pathways and building entrances; in combination with informal patterns for seating and other usable open space areas. Introduction of level changes, usable lawn areas, and a variety of hard surfaces is encouraged. *Existing example: "Education Plaza". Proposed Examples: Sciences Concourse, Regents Square*
- View Preservation – the predominant approach recommended in these guidelines is the creation and preservation of vistas into and within the campus, rather than outward toward the mountains.
 - Major vistas along campus streets and open space areas - these provide a linear view for pedestrians, visually organizing the open space and orienting the user; they also provide open space views from buildings facing the open space. *Existing example: Main Mall. Proposed example: Cherry Corridor*
 - View "windows" from arterial streets into campus - these include "windows" created by major openings between buildings (including widening of open space corridors) and the two formal campus entrances along Campbell Avenue. *Existing example: A.H.S.C. Entrance. Proposed example: Olive-Fremont Windows on Speedway Boulevard*
- Animation - to insure adequate animation of activity nodes and open space corridors, the following guidelines apply:
 - A variety of usable open spaces accommodating a range of activities is desirable.
 - For any open space, at least three types of seating should be provided.
 - Uses which draw people and people-watchers should be incorporated.
 - The use of participatory artworks and well designed water features is encouraged.
 - Major pedestrian routes should be incorporated.
 - Bicycle routes and/or major bicycle parking areas should be included.
 - Design elements should be employed to add color and festivity, and thus attract use.
 - Development at multiple levels -- such as sunken plazas, under-and overpasses, mezzanines, balconies, and arcades -- is desirable to encourage people-watching, as well as to provide visual interest.
- Visual Continuity - the design elements in open space development include planting materials; seating; surface treatments; lighting; special features such as food pavilions, transit stops, and information kiosks;

artwork; and associated buildings. Certain elements should be consistently employed on a campus-wide basis to provide visual continuity, harmony, and legibility:

- Palette of theme plantings for repeated use, in particular canopy trees lining pedestrian and bicycle paths.
 - Common building materials and colors for campus architecture.
 - Comprehensive campus signage and graphics system. (*Refer to UA Sign Committee & 2/97 Signage Standards.*)
 - Common surface treatments of pedestrian and bicycle paths.
 - Common lighting fixtures and supports.
 - For existing open spaces undergoing redevelopment, existing elements will be utilized to the extent possible. For new spaces, an overall character should be established which will be used as each new building and associated open areas are developed.
- Crime Preventive Design - the principles of crime preventive design and defensible space should be utilized in the planning and design of outdoor space, particularly for major pedestrian paths and usable open spaces. This means design which discourages criminal activity and encourages visual surveillance by campus users as well as campus police and security.
 - Sufficient night lighting must be provided along major pedestrian routes, in activity nodes, in parking areas and structures, and at major building entrances. The installation of emergency telephones in strategic locations should also be considered.
 - Landscaping and walls should be designed to maintain visibility between heavily trafficked areas, and not as screens for potential intruders.
 - Where possible, elevation differences, view "windows," and vistas should be used to encourage surveillance between intensely used pedestrian areas, and between pedestrian areas and well trafficked streets.
 - Design which encourages development of identifiable open space "territories" with which people associate themselves and neighboring users, is desirable. This is especially appropriate in campus residential communities.
- Screening – shall consist of screen plantings, walls or fences, berms or elevation differentials, or a combination of these measures. For most situations, screening should be a minimum of five feet in height. The following new facilities should be screened from view:
 - trash collection areas
 - delivery/loading areas
 - outdoor storage areas
 - major above grade utility installations
 - most surface parking lots
- Landscaping - at the outset of design of any facility or open space, a thorough site survey should locate and identify all existing on-site plantings. Healthy specimen trees and palms should be preserved "in situ" to the extent possible. If this is not possible, relocation should be considered in preference to demolition. A theme plant palette should be established, listing plants for repeated use on campus to further establish a sense of landscaping consistency. The following characteristics are desirable for plantings on campus:
 - low water requirements/drought tolerant;
 - non-allergenic;
 - ease of maintenance -preference for non-deciduous species dropping no fruit, clean species requiring little pruning;
 - non-invasive root systems;
 - pest and disease resistant.
 - There are certain exceptions to all of the above, depending on location, use, and historical value.

- Barrier Free Design - pedestrian routes and usable open spaces should be designed and landscaped to permit access and use by physically handicapped persons. Buildings, parking facilities and grade-separated crossings must be accessible to the physically disabled as well.
- Campus Legibility - equally important as campus signage in orienting people is the "legibility" of the campus -the capacity of the campus to provide users visual clues as to their location and direction of movement. A number of proposals embodied in the Plan are designed to enhance and augment the legibility of the campus for both the campus community and visitors:
 - Creation of distinct development use clusters or districts.
 - Redevelopment and development of identifiable activity nodes of usable open space (plazas, malls).
 - Use of landmark buildings to further distinguish activity nodes.
 - Further development of transition zones which provide a distinct campus edge along arterial streets and planning area boundaries.
 - Creation of campus gateways, in part defined by gateway buildings.
 - Enhancement and development of linear pedestrian corridors, most with major vistas to be preserved.
 - Use of campus theme plantings and campus color and materials palettes to provide a consistent, coherent "background" for special features (above).
 - Preservation of the historic district and wall of the campus.

CAMPUS TRANSITION ZONES

- The goal for University interfaces with non-University uses is as follows:

Treat functional and aesthetic interfaces with neighboring commercial and residential areas and with city streets as sensitively as possible.

- Arterial Streets - the following generally summarizes the guidelines applicable to city arterial streets. The purpose of the guidelines is to provide a high quality visual experience to motorists passing the University, as well as to cooperate with the city in maximizing the safety and efficiency of arterial streets. Treatment of the arterial street "transition zone" is incorporated into these guidelines.

- Building design:

- Limit building heights in proximity to the street to 4 to 5 stories. Step back any structures immediately adjacent to street if possible.
- Present a pleasant facade to the street, not an apparent "backside" of the building.

- Street treatment:

- Provide a continuous landscaped buffer along the street, retaining a sidewalk parallel to but not necessarily abutting the roadway.
- Further develop the existing landscaping pattern, if any, or establish a new pattern.
- Accommodate underground utilities.
- Encourage city to retain or install landscaped median.
- Provide directional graphics as needed.

- Visual access:

- Retain formal campus entrances.
- Provide designated campus gateways.
- Develop the proposed "windows" into the campus.

- Auto circulation:

- Close local streets as proposed in a timely manner, in cooperation with the city and adjacent neighborhoods.
 - Encourage Suntran to provide service at transit stops and terminals.
 - Work with the city in the design of arterial street widenings, grade-separated pedestrian/bicycle crossings, University parking structures, and intersection signalizations.
- Neighborhood Interface - in the Comprehensive Campus Plan, transition zones or buffers are indicated along the campus planning area boundary, adjacent to local streets and neighborhoods. These guidelines apply to the treatment of the transition zone or buffer, providing as sensitive a relationship by the campus to its neighbors as possible.
 - Timing
 - Recognize that development can occur at the current edge of the campus, versus at the campus boundary at full build-out. Therefore, some development may appear intrusive or insensitive to neighbors during the interim period. There also may be awkward circulation patterns on a temporary basis.
 - Screen new parking lots designated "permanent" or to be in place more than three years, with landscaping and/or walls or fences.
 - Implement the continuous buffer treatment (see below) as opportunities arise.
 - Uses
 - Place uses at the planning area boundary which are as compatible as possible with neighboring uses.
 - Maintain uses to a standard that is consistent with and will not detract from the overall appearance of the neighborhood.
 - The most appropriate uses are day-time oriented, creating no nuisances or disruption to neighbors, in particular the location of greenhouses in a "precinct" in the southwest quadrant of campus at Eighth Street and Park Avenue. *Examples: office uses, research facilities with no unusual noise or radiation concerns, such as greenhouses.*
 - Adult or graduate student housing is preferred to undergraduate housing.
 - Recreational facilities are appropriate if spillover noise and lighting can be controlled or night use limited to specified hours, and/or public neighborhood usage provided.
 - Mitigation of Possible Nuisances - the following are potential nuisances to neighbors, and should be mitigated to the extent possible during design:
 - Auto traffic volume and noise (see below).
 - Street parking (see below).
 - Spillover lighting.
 - Spillover noise.
 - Pedestrian traffic in high volumes.
 - Night usage.
 - Fumes or odors.
 - Shadow patterns (solar accessibility).
 - Run-off/drainage.
 - Criminal activity and vandalism.
 - Auto Circulation and Parking
 - Provide routes internal to the campus to accommodate most University traffic.

- Provide access to University buildings from internal campus streets; remove existing driveways entering local neighborhood streets where and when feasible.
 - Limit access to residential neighborhoods from the campus to selected streets, while closing most local streets within the campus planning area. Minimize parking impacts associated with the loss of on-street parking, such as the proposed closure of Fifth Street and Tyndall Avenue.
 - Cooperate with the city and neighborhoods in implementing the residential parking permit programs where necessary and the metering of street parking.
 - As a goal, bring all University-related vehicles into the campus parking system (including daily fees, metering, and annual permits).
 - Support city and neighborhood efforts in the installation of appropriate traffic control devices outside the Planning Area which has the net effect of reducing University related traffic impacts.
- Visual Quality
 - Building design:
 - Limit building heights at the campus perimeter to 2 to 3 stories.
 - Encourage the use of "step-back" designs (going from one or two stories, then up as further away from the boundary), especially adjacent to single-family residential areas.
 - Screen outdoor storage, refuse collection, and loading/delivery areas from view.
 - Where feasible, break up bulky structures into smaller masses and/or orient the long sides of buildings perpendicular to (not parallel to) neighborhood boundaries.
 - Consider the use of berming to reduce the perceived height of buildings.
 - Landscaped buffer:
 - Provide a minimum building and parking lot setback of 25 feet from the local street right-of-way for all new permanent construction.
 - Develop the setback as a continuous landscaped buffer, incorporating screen plantings; berms, walls, or elevation changes where feasible; a sidewalk a minimum of 5 feet in width; and night lighting.
 - Coordinate design of the perimeter landscape buffer with appropriate neighborhood constituencies, and be sensitive to existing historical streetscape elements.
 - Where campus streets intersect local neighborhood streets, plant the University street corners with more intensive and/or accent plantings.
 - Adjacency to uses to be retained:
 - For new construction, provide a minimum building and parking lot setback of 10 feet from the property line of uses designated for retention in the area plans.
 - Develop the setback as a landscaped strip, with screen plantings and/or walls, fences, or berms.

End of Tab C-2

TAB C-3

LABORATORY PLANNING AND DESIGN CRITERIA

TABLE OF CONTENTS

General Laboratory Planning and Design Precepts	Page	2
Flexible Laboratory Planning	Page	3
Modular Laboratory Planning	Page	4
Handicapped Accessibility in Laboratories	Page	4
Planning and Design for Laboratory Safety	Page	5
Casework	Page	6
Equipment and Appurtenances	Page	8
Finishes	Page	9
Utility Service and Distribution	Page	9
Air Management Technology	Page	12

NOTE

- These criteria are intended to apply to both new construction and renovation projects. Obviously, minor renovation projects will not be expected to comply with broad scope criteria, such as redesigning the entire building to satisfy the “modular planning” goal. Wherever these criteria can be reasonably applied to renovation projects with a resulting improvement in the lab environment and without excessive cost penalties, the University desires to do so.

- **General Laboratory Planning and Design Precepts**
 - Utilize a central core for special spaces, shared spaces, and building service areas
 - Array laboratories around the perimeter of the building
 - Locate offices and circulation spaces between the core and the perimeter labs
 - Separate office spaces from the labs
 - Maintain adjacency and visibility to labs
 - Provide a hierarchy of office spaces
 - Faculty
 - Graduate students
 - Research technicians
 - Provide a variety of informal gathering spaces, with tack and marker boards in each
 - Eddy spaces in corridors (in addition to lab door recesses)
 - Lounges
 - Break rooms
 - Consider providing clean and “dirty” corridors
 - Clean corridors are restricted to people circulation
 - “Dirty” corridors can not be considered as secondary means of egress
 - “Dirty” corridors provide:
 - Utility distribution
 - Air distribution systems
 - Lab equipment (refrigerators, etc)
 - Building equipment (compressors, air pumps, etc)
 - Circulation route for sensitive items
 - Air pressurization hierarchies are critical
 - Ensure adequate space provisions for major equipment
 - Restrict size of main corridor (code minimum?) to prohibit placement of equipment
 - Utilize a hierarchy of equipment spaces:
 - Shared group spaces in the core
 - Floor space allowance in the “dirty” corridor
 - Open floor and/or space in each lab
 - Available floor space for cart parking
 - Bench top space for analytical equipment (as appropriate)
 - Recess outswinging lab doors off the corridor
 - Ensure adequate provisions for bulk storage
 - Provide storage for all types of materials required:
 - Dry goods
 - Chemicals
 - Bottled gasses
 - Utilize a hierarchy of distributed storage spaces:

- General building storage
- Floor closets
- Lab closets
- Millwork cabinets
- Open and/or closed shelving

- Design bulk storage areas with appropriate fire resistance ratings for materials and quantities

- Bulk chemical storage facilities should have these characteristics:
 - Perimeter location
 - Vented room
 - 2-hour fire resistant construction
 - Consider including "blow out" panel

- More than 10 gallons (in the aggregate) of class I chemicals must be stored in a cabinet
 - Provide adequate floor space in chemical storage rooms for individual cabinets

- **Flexible Laboratory Planning**
 - Plan lab facilities with a distributed hierarchy of shell space for future build-out
 - Floor shells and/or wing shells, as appropriate
 - One or more module shells
 - Semi-custom shells
 - Special shells

 - Provide complete utility service into each shell
 - Plan laboratories as "generic" spaces
 - Accommodate different categories of generic labs
 - Wet
 - Dry
 - Teaching
 - Research
 - Biology
 - Chemistry
 - Biochemistry
 - Electronic
 - Geology
 - Physics

 - Accommodate "exceptions" and unique conditions in separated custom-purpose spaces
 - Animal holding
 - Biohazard activities
 - Cold rooms (storage or working)
 - Electron microscope
 - Environmental
 - Laser
 - Radioisotope activities
 - Tissue culture activities

- Consider use of "semi-custom" spaces (in modular increments) to provide flexible and/or adaptable space for activities which present unforeseen requirements
- Provide connecting doors between homogenous lab categories (may be used as secondary egress when part of a rated area separation assembly)
- Design lab infrastructure with flexibility to accommodate different categories of labs and/or future design changes without a need to revise the infrastructure systems
 - Piped utility distribution
 - Waste and vent systems
 - Air management
 - Power supply
- Ensure that all equipment and appurtenances maintain the flexibility established in the basic planning and design
 - Modular benches, wall cabinets, shelving
 - Removable benches to allow increasing equipment floor space
 - Coordinate lab top seams with joints in casework
 - Allowance for items such as cylinder racks
- **Modular Laboratory Planning**
 - Design labs using a planning module
 - Module selection should incorporate the following determinants:
 - Building structure (and vibration considerations)
 - Typical bench needs and sizes for each lab category
 - ADA access requirements
 - Ceiling panel modules
 - Epoxy top modules
 - 10'-6" seems to accommodate lab activities and ADA requirements
 - Maintain consistent modular planning throughout the facility
 - Lab "length" is multiple of lab "width"
 - Special use, exception, semi-custom areas
 - Offices
 - Provide for unique "in-lab" needs within the module or multiple modules
 - Provide complete array of utility stubs to each module, even if not always distributed
- **Handicapped Accessibility in Laboratories**
 - Design typical lab benches to be 34" high
 - Provide sit-down handicapped accessible workstation in each lab
 - Appurtenances for each HC station will vary with the category of lab, but in general should include
 - Bench at approximately 30" high
 - Hood
 - Sink with wrist blade faucet handles
 - Lab gasses with wrist blade cock handles
 - Power
 - Storage facilities

- Writing surfaces

- Appurtenances must be within regulation-specified reach distances
- Investigate whether sit-down writing surfaces available to all lab users could be designed to accommodate an HC station when needed
- Investigate whether removable benches and/or equipment could be designed to allow retrofit for HC accessibility

- **Planning and Design for Laboratory Safety**
 - Resolve lab exiting issues
 - Investigate a design scheme which utilizes "lab suites" thereby allowing individual lab doors to be left open while preventing true corridor doors from being blocked open
 - Investigate providing magnetic hold open / pneumatic closer devices on lab/corridor doors

 - Chemicals management
 - More than 10 gallons (in the aggregate) of class I chemicals must be stored in a cabinet
 - Provide acid, solvent, and/or flammable storage cabinets for supply chemicals as appropriate in each lab
 - Under hood or free standing as required by quantity to be stored
 - Properly vented
 - Cabinets should be compartmented to allow segregation of chemicals

 - Provide space for storage of waste chemical containers

 - Utilize chemical fume hoods only for lab processes, not for storage

 - Utilize canopy hoods and/or snorkels to remove heat only
 - Autoclaves
 - Dishwashers
 - Certain analytical equipment

 - Provide emergency showers with "hands free" eyewash in corridors
 - Locate within 50 feet of each lab door
 - Do not provide showers in labs
 - Provide a 2" floor drain at each shower location.
 - Provide a local warning alarm for water flow

 - Provide flexible hose eyewash at each major bench sink

 - Provide adequate space, outside traffic areas, for waste handling
 - Provide secured storage/space for sensitive waste
 - Provide vented storage/space for hazardous waste (maximum 5 gallon container)
 - Utilize a distributed hierarchy of waste spaces
 - Building
 - Floor
 - Individual labs

- Waste categories include
 - Ordinary trash
 - Recycled paper
 - Other recyclables
 - Broken glass (secured)
 - Waste chemicals (secured, vented)
 - Red bag (secured)
 - Orange bag (secured)
 - Radio-hazard (secured)
- Provide a separate break away from labs. Provide space for microwave, refrigerator, coffee pot, sink, etc.
- Provide vision lite in every lab/corridor door
- Provide a fire extinguisher rated for materials being used in lab on a hook in each lab room
- Alarm systems
 - Provide mini-horn/strobe units in environmental rooms and in labs
 - Do not provide smoke detectors in corridors
- Biosafety levels
 - Not all laboratories present a biohazard condition requiring primary and/or secondary barriers
 - Hazards are classified by biosafety level, and required physical barriers are described
 - Biosafety level 1
 - Handwashing sink
 - Biosafety level 2
 - Class I or II biosafety cabinets may be required
 - Waste decontamination facilities
 - Biosafety level 3
 - Class I or II biosafety cabinets are required
 - Glove boxes may be required
 - Access control to the laboratory
 - Specialized mechanical ventilation
 - Biosafety level 4
 - Class III biosafety cabinets are required (or personal pressure suit)
 - Separate building or completely isolated zone
 - Specialized mechanical ventilation and waste management systems to contain hazards
- **Laboratory Casework**
 - Provide wood casework
 - Natural finish, not plastic laminate
 - Except where matching existing metal
 - Except in areas requiring impervious surfaces

- Animal care areas
- Biohazard areas
- Radioisotope areas
- Chemical storage rooms

- Include utility chase behind wall/peninsula/island base cabinets
- Demonstrate functional useability of corner area where two base cabinets intersect
- Provide removable access panels at knee spaces and sink cabinets
 - Rear stretcher at knee space should be continuous

- Provide pull out writing tablet in casework, using drawer glides
- Provide heavy duty full extension drawer glides (100 pounds minimum)
- Provide pre-fabricated specialty chemical and flammable storage cabinets where required

- Laboratory bench tops
 - Epoxy resin tops at all wet or semi-wet areas
 - Acid resistant plastic laminate at dry areas
 - Provide dished top at all major lab sinks
 - Provide lip at all sinks in labs
 - Locate seams in tops coincident with seams in benches to allow for modifications
 - Use light colored tops if lighting efficiency can be demonstrated

- Wall / peninsula / island reagent shelving (above lab benches)
 - Custom fabricated using unistrut-type system (not stock item)
 - Extend unistrut from floor through bench top to structure above
 - Seal penetration with epoxy seaming material
 - Do not use a "wrapped splash"
 - Earthquake lip (12" or 18" clear dimension)
 - Acid resistant plastic laminate on wood substrate
 - Do not use an epoxy paint or clear finish
 - Do not install reagent shelving above sinks

- Enclosed wall reagent cabinet (above lab benches)
 - 12" clear dimension
 - Glass or opaque doors as requested by User
 - Do not install wall cabinets above sinks

- Wall shelving (non-reagent)
 - Must have backing in wall
 - Clear finish wood
 - Heavy duty adjustable kv-type brackets
 - End caps
 - Use unistrut-type reagent shelves for extra deep wall shelving
 - Install top-most shelf 24" minimum below ceiling
 - Do not install wall shelving above sink

- **Laboratory Equipment and Appurtenances**

- Provide a 3'-6" minimum single leaf at each lab/corridor door
- Discuss fume hood selection with UA Facilities Design & Construction
 - Investigate special user requirements
 - Laminar flow clean hoods
 - Radioisotope hoods
 - Perchloric acid hoods
 - Biosafety cabinets
- Laminar flow clean hoods
 - Used only to protect process (not to protect operator)
 - Not exhausted
- Radioisotope hoods
 - Special purpose fume hood with hepa-filtered exhaust discharge
 - Generally uses slightly higher face velocity than conventional fume hoods (125 fpm)
 - Requires welded stainless steel exhaust duct system
 - Can be open or gas-tight (glove box)
- Perchloric acid hoods
 - Straight exhaust duct run (no horizontal offsets) is mandatory
 - Requires automatic wash down system
 - Timer-controlled for washing once per week
 - Discharge must be carried to the lab waste system
 - Requires welded stainless steel exhaust duct system
- Biosafety cabinets
 - Identify specific type of hood required, based on User process
 - Class I biosafety cabinet: 100 fpm, single pass air, out through hepa filter
 - Class II-A biosafety cabinet: 100 fpm, 70% recirculated through hepa, 30% exhaust to room through hepa
 - Class II-B1 biosafety cabinet: 100 fpm, 30% recirculated through hepa, 70% exhausted to exterior through hepa
 - Class II-B2 biosafety cabinet: 100 fpm, 100% exhausted to exterior through hepa
 - Class II-B3 biosafety cabinet: 100 fpm, 100% exhausted to exterior through hepa, plena under negative pressure to room
 - Class III biosafety cabinet: gas-tight cabinet, supply through hepa, exhaust through 2 hepa
 - Biosafety cabinet exhausts may be manifolded together, but not with chemical fume hoods
- Exhaust hood control
 - Chemical fume hoods may not be User controllable, must be on 24 hours

- Also includes radioisotope and perchloric acid hoods
- Consider off-hours setback and vav systems, for energy conservation

- Interior recirculation ("supply") fans of biosafety cabinets may be User controllable
 - Must be interlocked with hood and/or general exhaust fans to ensure that operator safety and room pressure are not compromised
 - Applies to all class II biosafety cabinets, only

- Provide tank farm with chains, not dividers, when required
 - Design to be near the door, for ease of service
 - Utilize University-standard tank manifold

- Provide wall space for UA-standard towel and soap dispensers at each lab sink
- Provide tack surfaces and writing boards in all labs
- Carefully coordinate all equipment specifications
 - Fixed or moveable, must specify details
 - Sizes and floor space allowances

- Use electric autoclaves instead of steam

- **Laboratory Finishes**
 - Floor finishes
 - Available choices
 - Vinyl composition tile is appropriate for most labs
 - Epoxy sealer is also appropriate for most labs, including chemistry
 - Seamless vinyl provides a "pan" in very wet areas
 - Seamless vinyl is cleanable for biology labs

 - Continue flooring under casework
 - Seal toekick of all benches (to prohibit water penetration)
 - Use topset cove base at toekicks

 - Provide epoxy wall paint in all wet labs
 - Also on ceilings, if hard surface

 - Ceilings
 - Available options
 - Suspended acoustical tile ceilings are acceptable in most laboratories
 - No ceiling is an option where appropriate
 - Provide hard ceilings only where required by lab activity

 - Provide a sealed sleeve with a lip at all floor penetrations

- **Laboratory Utility Service and Distribution**
 - Utilities distribution

- Overhead, in corridor ceiling
- Valve on each utility stub, in corridor
- Drop on wall surface or freestanding to each lab bench
- Distribute to positions in utility space at rear of casework
 - Make joints in horizontal piping only at removable panels
- Visible and accessible
- Consider special delivery systems where appropriate
 - Lab gas "pedestal" or "drop pods"
 - Electric "drop cords"
- Utilities on bench tops
 - Place turrets toward rear of bench
 - Use turrets with angled discharge to enhance hose management
- Utilities racked on reagent shelf
 - Generally avoid (hoses get in the way)
 - If doing so, rack on unistrut verticals, not shelf
 - If doing so, maintain 22" clear height above bench top
- Piped utilities
 - distribute to benches and hoods
 - controls must be outside hoods
- building provides central
 - potable water
 - ro water
 - Provide special (di) polish at individual labs
 - Natural gas
 - Some Users prefer bench top cylinders for gas service
 - Compressed air
 - Confirm if required
- Building does not provide central
 - Vacuum
 - Hot water
 - Specialty gasses
 - Provide in individual lab as needed
- Use building chilled water wherever possible for process

- Provide heat exchanger between building and process
- Recirculate chilled water (do not use "single pass")
- Where demand is excessive, varies from building system, or need is critical
 - Use stand alone chiller
 - Consider placing chiller on emergency power system
- Waste system and piping
 - Do not use acid neutralization systems (building or stand-alone)
 - Separate lab waste from domestic waste
 - Utilize separate piping system to exterior of building
 - Provide sampling manhole for lab waste piping
 - Combine lab and domestic waste piping after sampling manhole
 - Use acid-resistant piping system for lab waste
- Lab sinks
 - Confirm with User need for large/deep sinks
 - Plan major sinks at ends of benches, in base cabinet
 - Use gooseneck faucets with wrist blades at all sinks
 - Cup sinks are not routinely needed on benches or in hoods
 - Install only is specifically required
 - Always provide lip
 - In hoods, sink must be at rear to avoid trap being in under-hood storage cabinet
- Do not use plastic di faucet
 - Aluminum faucet (with plastic piping) is acceptable
 - Self-closing
 - Easily replaceable
- Floor drains
 - Use only when required to discharge condensate or other similar non-hazardous material
 - Must be lipped and guarded
- Electrical & telecommunications typically required
 - Provide an adequate number and arrangement of circuits
 - Provide an adequate number and arrangement of 120v receptacles
 - Provide an adequate number and arrangement of 208v receptacles
 - Provide wiremold electrical distribution above all lab benches
 - Double raceway
 - Install quantity of receptacles as required by User process
 - Receptacles above bench must have gfcı protection *within 5' of water source*
 - Install of data jacks as required by User in second raceway
 - Label each receptacle's circuit

- Alternate circuits in each lab and in each wire mold run
- Provide wall phone jacks where required. Do not provide data jacks at wall phone jacks.
- Provide data jacks along benches where required.

- Lighting
 - Place general fixtures to eliminate shadows from work surfaces
 - Do not rely on general fixtures for the complete lighting environment
 - Provide task lighting above lab benches and other work surfaces
 - Utilize 2-tube fixtures with shades to minimize glare
 - Evaluate color and reflectivity of finishes and bench tops as part of lighting design
 - Provide emergency lighting in each lab room or distinct space

- **Laboratory Air Management Technology**
 - Preferred system
 - Building ahu to supply make up air to labs
 - Lab fan coil units to remove sensible cooling load of lab equipment
 - Investigate manifold and vav exhaust system if project has many hoods
 - Use multiple fans in manifolded system
 - To allow programmed maintenance
 - Basic system design issues
 - Provide pressure hierarchy between lab spaces
 - Provide capability to measure velocity and pressure downstream of terminal boxes
 - Provide exhaust discharge velocity of 3000 - 3500 fpm
 - Provide bypass on manifold vav systems at roof
 - Provide filtration or scrubbing for hazardous emissions
 - Temperature control
 - Set individual room thermostats at 75°F, ± 2°F
 - Humidity control – discuss with UA FDC
 - Filtration requirements
 - Provide minimum 4" deep 30% efficiency filter banks in 100% outside air systems
 - Design exhaust systems for materials being removed
 - Heavier or lighter than air
 - Concentrations and processes
 - Discuss design hood face velocity with UA FDC
 - Limit use of canopies and snorkels to heat removal

- Ductwork materials
 - Spiral 316L stainless steel shall be used for fume hood applications
 - PVC coated galvanized may be used on manifold vav systems applications
 - Clearly specify strict construction controls
 - Welded 316L stainless steel must be used for perchloric acid hoods
- Design exhaust system for noise reduction
 - Duct size, design, and route
 - Fan selection and location
 - Low pressure drop hood
- Specify appropriate vent conduits for storage cabinets
 - Explosive / flammable
 - Vapors

TAB C-5

CUSTODIAL PLANNING AND DESIGN

Custodial Services are inherent to the operations of buildings and proper service areas must be considered with all other areas during the programming and planning stages of each building.

Universally accepted standards have yet to be set for custodial closets and storerooms. Certain criteria however, for size, shape, location, and special appurtenances, have been developed which are compatible with present cleaning procedures and today's cleaning equipment.

Comprehensive custodian operations encompass three major areas:

- Custodial Closets
- Custodian Storage Areas
- Trash Disposal Systems

- CUSTODIAN CLOSETS

Should be planned to function primarily as the workrooms of men and women responsible for cleaning the interior surfaces of the building. The University of Arizona has developed the following criteria for custodian closets:

- Size should be a **minimum** of 80 – 100 square feet, with 7-8 foot minimum width.
- Recessed light fixtures (to allow for clearance of long broom and mop handles) providing 75 F.C. light.
- Adequate ventilation.
- Pegs for storage of rotary brushes.
- Hangers for wet mops over the sink.
- Hangers and wall space for dust mops and brooms.
- Hard surface walls impervious to water.
- Shelves in closet to accommodate supplies in case lots, and to allow for storage of liquids in original 5 or 6 gallon containers.
- A 36" wide door that swings out, not into the room.
- Hot and cold water outlets not less than 24" above a floor type basin. Basin curb should be 6" minimum above the floor.
- A grounded 20 Amp. Duplex outlet in open wall space, not behind shelves, for recharging battery operated equipment.

Location of custodian closets is very important. They should be centrally located with no area in a building more than 150 feet in walking distance from a "wet" closet. Each closet should not serve in excess of 15,000 square feet.

Buildings should have custodian closets on every floor. Good locations for secondary custodian closets are:

- Close to elevators
- Close to main pedestrian areas
- Between two restrooms

Criteria For Vertical Transportation

- There should be an elevator in every multi-storied building.
- The elevator should land on every floor including the basement.

- The elevator should be available to custodian and maintenance personnel.

It is considered poor planning to locate a custodian closet:

- At the dead end of a corridor. A situation such as this results in many unnecessary steps for the custodian.
- On a stair landing. A stair-landing closet would cause the custodian to always carry utensils and equipment up and down stairs.
- Inside another room (unless that closet serves only that room).
- Under stairs. Low ceilings and narrow dimensions are hard to ventilate.
- In narrow spaces. The custodian must move his equipment into the hall to utilize a narrow room. Square shaped closets are most efficient.

Telephone switching gear, elevator controls, electric panels or other service functions are not compatible with custodian operations, and should not be located inside custodian closets. Openings to pipe chases or mechanical equipment areas should not be located inside custodian closets.

- **LARGE STORAGE ROOMS**

- Every large building should have a storeroom for custodian equipment, bulk supplies and custodian lockers. Buildings larger than 150,000 sq.ft. should contain two such rooms. Storage areas should be designed specifically for custodian storage, not for dual usage. Planning should be done in consultation with those who will be responsible for maintaining the building.
- Dock or elevator facilities must be provided.
- Doors should be no less than 36" wide and open out. Storage areas should contain a minimum of 144 square feet. 12' x 12' are good dimensions.

- **TRASH DISPOSAL**

- Disposal of the trash and garbage produced by every cleaning operation is an integral part of a comprehensive program. The University of Arizona's Physical Plant utilizes compaction and physical removal by truck for all trash and garbage. A properly sized, fire-resistant trash room shall be planned into each new campus building. Where debris from kitchens and dining halls, or where animal matter is involved, refrigerated trash storage rooms shall be provided.

- **SUMMARY**

- Proper custodian closets, carefully planned and sized storage rooms or custodial supplies, and consideration of refuse collection and disposal requirements, are prime ingredients in any efficient housekeeping program.

TAB C-6

KEYLESS ACCESS AND SECURITY SYSTEM GUIDELINE

The University of Arizona has implemented a Keyless Access and Security System program to provide a cost effective, efficient, and maintainable means of providing and managing access into campus buildings for the university community, contractors and visitors. The focus of the system is to address issues of loss prevention, personal safety, and convenience through the use of this standardized technology. The system utilizes the University's CatCard as the "key" since it is universally deployed to all campus constituencies.

The principle focus of the program addresses **building perimeter access points**. Most University facilities are unlocked during normal (and sometimes extended) business hours, during which time keys are not required to enter the building. However, when the buildings are supposed to be closed and locked, it is the program's intent to provide entry through the use of the University of Arizona CatCard rather than with the use of a physical key.

Effective physical and electronic security is essential in providing security, access and protection to University students, personnel and assets and to mitigate threats or hazards, either natural or human-made.

The objective of the program is to provide increased security and public safety by deploying electronic access controls, door status monitoring, security systems and rekeying the perimeter access points of all major University buildings. This protocol will also be applied to new building projects, remodeling projects or additions to existing buildings.

The Keyless Access Program is intended to minimize the need for the traditional hard keys related to perimeter access to buildings. It is the intent to provide Keyless Access and Security on each side of the building to provide access to user, emergency personnel, and maintenance staff as well as facilitate future needs of the building. As the program has developed it has been determined that the use and issuance of necessary hard keys and the related hardware needed for these various doors must be addressed and clearly defined.

After hours building access will be granted by presenting a valid UA Cat Card and PIN, creating an audit trail. Building entrance doors will be rekeyed off building masters reducing the liability of lost or stolen keys. Emergency override keys will only be issued to emergency responders. The locking and unlocking of designated entry doors will be accomplished electronically, according to established schedules.

This program also integrates the room and course scheduling protocol into its operation.

When completed, this program also facilitates the ability of UAPD and /or FM Administration to remotely lock the perimeter doors of a specific building, a group of buildings, or the entire campus based on the demands of any critical situation that may occur.

Because this functionality is directly related to the locking hardware utilized on the various door configurations it will be necessary to refer to an enhanced Division 8- Doors and Windows of the DSS to clearly identify the correct door hardware, keys and keyways necessary to provide the correct functionality for each designated door.

Depending on building and layout, access points will operate in the following manner:

- Designated perimeter doors will be electrically locked and unlocked according to electronic schedule, but capable of authorized Cat Card Reader/ PIN entry after hours or on weekends.
- Secondary perimeter doors will be electrically locked and unlocked according to electronic schedule but without a Cat Card reader.
- Egress only doors will remain locked at all times.
- All perimeter doors will be equipped with door status contacts and have dog down devices removed after rekeying. This is required to provide remote perimeter lockdown capability in at threat situation.
- Designated doors will also be equipped with audible devices to sound when doors are opened during an unauthorized time.

- All roof access points and tunnel entries will be protected with a contact or motion detector based on field conditions.

REFER TO ATTACHMENT A for a door matrix to clarify the various components needed to configure doors to comply with the intent of the DSS

In order to equip new university building with this system, project consultants will need to provide a design and produce construction documents that have the following accommodations for a keyless access and security system:

- **RISER** - A riser for the building's Keyless Access/Security System. This riser is required to be stacked vertically within a building to permit the Keyless Access/Security System to be wired from floor to floor. Each building usually has a MDF room and several IDF rooms located throughout the building, each of these rooms will be equipped with access control. (REFER TO ATTACHMENT B)
- **HEAD END EQUIPMENT** - Space and some utilities for the Keyless Access/Security System head end equipment directly adjacent to the riser. This particular equipment exists on only one floor of the building. This equipment also needs to be provided with two electrical 120VAC circuits consisting of one hard wired connection and one duplex outlet and two telecommunications data jacks. (REFER TO ATTACHMENT C)
- **FIELD DOOR CONTROLLER PANELS** - Space and power for Keyless Access field door controller panels at various locations throughout the building as determined by the keyless access system design. Each panel requires a single hard wired 120VAC power circuit. This equipment is usually located in the various MDF and IDF rooms with the proper authorization from UITS group.
- **RACEWAYS** - Conduit and junction boxes will need to be provided for routing certain portions of the Keyless Access/Security System local area network. Not all of the keyless access and security system wiring is required to be located in conduit. In very general terms, conduit is required between the equipment that is installed on walls up to accessible, above ceiling space or to the building's cable tray. The various boxes related to this system have specific height requirements and these details are shown on the drawings and on the submittal documentation.
- **DOOR HARDWARE** – Designated doors will have hardware that needs to interface and/or be controlled by the Keyless Access system. Doors that have keyless access hardware requirements may either have their hardware specified and provided under the general construction contract (for example – in the door hardware package) or have their hardware provided by Amer-X as part of the Keyless Access/Security System installation. All door hardware must have prior approval and be provided in a configuration that will support both 12 and 24 volt DC operation. Doors that have mullions must have a quick release plug associated with the electric strike.
- **DOOR FRAMES** - Doorframes - pre-prepared from the manufacturer that can easily accommodate the addition of equipment for electronic operation. These frames typically include a handy box at the top of the doorjamb and a latch strike mud pocket that is deep enough for an electronic strike. Due to the variety of door and frame configurations these items must be clearly defined prior to bidding.

Consultant shall coordinate door functions, keyless access and security provisions, door frame requirements and Tab C-12 Campus Accessibility guidelines during the early design phase of a project. Include at this time the close coordination and interface with any automatic door operators (ADO's) and the fire alarm system.

After the award of the respective sub-contracts and prior to start of door related construction a meeting will be coordinated by the General Contractor and include the General Contractor, Electrical Contractor, Hardware Supplier and Amer-x to verify the coordination of the various hardware sets and the operation of each set as it interfaces with the access control system. This meeting will also include the electrical contractor to verify and agree on all conduit requirements.

All the Keyless Access/Security System wiring is low voltage; only the head end equipment and field door controller panels require 120VAC. As such, most of the wiring is not required to be located in conduit. The Keyless Access/Security System is not required to be provided with emergency power; each building's system is provided with sufficient battery backup to provide at least four hours of standby operation. In the event a particular installation calls for longer standby power capability, the 120VAC power could be on an emergency

circuit. The building Keyless Access/Security System communicates with the main server through data lines and requires connection to a hard wired network.

The following information is intended to explain the detailed requirements of each portion of the Keyless Access/Security System infrastructure and to define the items that need to be provided by the general construction contract.

RISER (Refer to Attachment B)

- A minimum 2- 2" riser conduits for each major wing of the building. The riser must serve every occupied floor of a building.
- One 12"x12"x4" riser box at each floor (see Notes below).
- 2- 1" conduits from the riser box to the building's cable tray.

Notes:

- A building may only have one riser, but larger, more complex buildings may have more than one.
- Amer-X will provide the riser boxes for each floor of the building.

HEAD END EQUIPMENT (Refer to Attachment C)

Security Control Panel

- One 16"x16"x4" box for security control panel (see Notes below)
- One duplex 120VAC receptacle for panel power. This receptacle is not required to be on emergency circuit. The circuit for this receptacle is not required to be dedicated.
- One data jack.

Notes:

- Installation of security system wiring and the network and phone line between control panel and voice/data jack is provided by Amer-X.
- 120VAC-16.5 VDC transformer and transformer cover for the power receptacle will be provided and installed by Amer-X.
- Amer-X receives the box for security panel from the equipment manufacturer. Amer-X will provide this box to the electrical contractor for installation during building construction.

KEYLESS PANEL AND NETWORK CONNECTION (Refer to Attachment C)

- One 16"x22"x6" box for keyless access panel and network connection (see Notes below)
- One hard wired 120VAC circuit. This circuit is not required to be on emergency circuit. The circuit for this receptacle is not required to be dedicated.
- Door hardware power supply
- One data jack.

Notes:

- Installation of keyless access system wiring and the network connection cord between control panel and data jack is provided by Amer-X.
- Amer-X will terminate hard wired circuits in respective panels
- Amer-X receives the box for keyless access panel from the equipment manufacturer. Amer-X will provide this box to the electrical contractor for installation during building construction.

FIELD DOOR CONTROLLER PANELS

Depending on the number and location of controlled doors, keyless access field door controller panels will need to be installed at various locations in the building. At each of these locations, the following equipment is required:

- One 16"x22"x6" box for the field door controller panel (see Notes below)
- 120VAC power hardwired into the box. This circuit is not required to be dedicated or on emergency power.

Notes:

- The panels can be installed above accessible ceilings, in equipment rooms, or other similar

- areas.
- The 16"x22"x6" holds the largest field controller panel. This size box may not be needed at every location, but space should be provided to accommodate the "worst case" box.
- Amer-X receives the boxes for the field controller panels from the equipment manufacturer. Amer-X will provide these boxes to the electrical contractor for installation during building construction.
- Gutter Boxes 18"x6"x6".

RACEWAYS

All of a building's perimeter access points will need to be provided with a wiring pathway that will permit the doors to be controlled electronically. Each building perimeter access point shall be provided with the following equipment:

- Door Contacts.
- Electronic Locking (either electric strikes or latches, or electric levers or magnetic locks (only with prior approval).
- Request to Exit Device.

In addition, certain, designated building entries (as determined by the Keyless Access/Security System design) shall be provided with the following additional keyless access equipment:

- Card reader
- PIN pad

Raceways will need to be provided from accessible, above-ceiling spaces to this equipment at each door where this equipment is located. Closely coordinate all equipment locations and function with accessibility guidelines noted in Tab C-12 and any automatic door operators that may be required. In many cases a raceway will be provided from door equipment to the nearest building cable tray.

Notes:

- If magnetic locks are used on a door, a keyed bypass switch will be required. This is an additional piece of equipment that will also require conduit to the accessible, above-ceiling space. Magnetic locks also require a designated push to exit device and must be interconnected with the building fire alarm.
- If electrified levers are used this will require that the door hardware contractor provide devices to transition the power from the frame side to the door. The hinge wiring must be sized to handle the power requirement of the lever
- For storefront-type entries, the Keyless Access/Security System wiring can be routed through the storefront mullions. This is a field installation coordination issue that Amer-X addresses with the storefront installers during construction.
- For some glass entries, a post or bollard pedestal will be required to mount some of the keyless access equipment (card reader, PIN pads). This type of installation requires greater consideration during the project's design phase. SEE ATTACHMENT J for standard bollard pedestal detail that can be provided by Amer-X. Bollard pedestal is intended to also contain an ADO access button if required.

DOOR HARDWARE

Electronic locking requires special hardware for the doors designated to be controlled by the Keyless Access/Security System. In general terms, there are three types of electronic locking hardware: electric strikes, electric latches, and magnet locks. Until the building's design reaches a point where the door types are well defined, it cannot be determined which type of electronic locking hardware will be used. However, the following should be considered:

- Magnetic locks are generally the most costly way to electronically lock a door. They should only be used when the other two alternatives are not feasible (i.e. double doors that require panic hardware and cannot have a mullion).
- Electric strikes can be installed in almost all doorframes or mullions and are the most economical way to electronically lock a door.
- Electronic latches are typically used where the door is required to remain positively latched (i.e. fire doors) in the event of a Keyless Access/Security System failure.

- Based on code requirements it may be necessary to provide fail safe or fail secure electrified locking devices.
- Electric strikes maybe more noisy than electric latching hardware and despite their higher cost the latter maybe preferred in quiet areas, i.e., classrooms, seminar spaces, study areas, etc.,
- There may be some need for the electric strike to be located in the header. This will require prior approval and special care with the installation.

DOOR FRAMES

Installation of electronic locking on doors is facilitated by having doorframes pre-prepared from the manufacturer for electronic hardware and controls. This entails the following

- A handy box provided at the top of the door frame, located 6 inches off the latch side of the frame.

ACCESS/SECURITY SYSTEM INSTALLATION

As the University's sole source, keyless access and security systems vendor, Amer-X performs the following installation tasks associated with the keyless access and security system:

- Installation of head end and field panels in boxes installed by the electrical contractor.
- Installation of 24VDC transformers and transformer covers on duplex receptacles installed by the electrical contractor.
- Connection of power source to panels.
- Connection of phone/data lines to jacks installed by the electrical contractor.
- Coordination with construction trades, such as window and door installers, to facilitate installation of peripheral devices.
- Installation of peripheral devices (door contacts, card readers, PIN pads, ADO buttons, electric strikes, etc.)
- Installation of the low voltage Keyless Access/Security System wiring - both in conduits provided by electrical contractor (in walls and vertically through the building) and the data loop local area network wiring between panels and devices (routed similar to telecommunication lines through above ceiling spaces).

DESIGN PHASE INVOLVEMENT

Please refer to the following process descriptions for how Amer-X should be involved in the design process.

DESIGN PHASE INVOLVEMENT, PROCESS AND FLOW CHART

Schematic Design

- Consultant, User group, and Amer-X meet.
- Introduction of keyless access/security system.
- Review building layout, functions, different building constituencies, and expected building operation. See Note (1) below.

Design Development

- Amer-X develops preliminary system design and budget. Submits copy to Project Coordinator, Consultant, and User group.
- This document will show the various doors we plan to equip with card access and security. Each door will be identified by room number and show the various devices needed at each door. The size and scope of this safety and security program requires that the required supporting drawing and specification documentation information be part of the bid documents to ensure that the infrastructure is provided and that if changes are needed the proper audit trails can be followed.
- Refer to Attachment D for the symbol list.
- Refer to Attachment E for reference on floor plan.
- Consultant, User group, and Amer-X meet. Review preliminary design with user and consultant. Make modifications/deletions/additions as determined by refined understanding of building operations and close

coordination with accessibility guidelines contained in Tab C-12.

- Amer-X develops final system design and budget. Submit copy to Project Coordinator, Consultant, and User group. Provides standard door details, riser diagram, door hardware requirements to consultants.

Construction Documents

- Amer-X verifies coordination of consultant documentation with final system design.
- The architectural drawing will show a card reader symbol at each door that will be equipped with card access. The symbol will indicate the location of the reader and any related components as it relates to the door. Any door requiring pedestal will also show this location.
- Refer to Attachment F for reference.
- The electrical drawings will indicate a symbol at each door that will be equipped with card access or security. The symbol will indicate a reference to a door detail illustrated on a separate sheet or sheets in the electrical drawings.
- Refer to Attachment G and H for reference.
- The Door Hardware Index will list all doors that require electrical components.
- Refer to Attachment I for reference.

Construction Phase

- Electrical Contractor installs pathways (riser and door conduit) according to specifications and drawings.
- Door contractor preps doors and jambs for equipment, according to specifications and installs door hardware.
- University establishes purchase order with Amer-X for system installation.
- Amer-X coordinates field device installations with affected contractors.
- Once the construction phase of the project is completed the systems will be commissioned and become operational under the University of Arizona keyless access and security policy and procedures.

Schematic Design Note (1):

Amer-X meets with consultants and user group(s) after schematic design to introduce the keyless access/security system program, and describe the system's capabilities and options. This is where the dialog on how the users expect the building to operate from an access point of view begins. A review of the functions that take place in the building, the different user groups/constituencies, and any special concerns about asset protection, special activities (cash handling, pharmaceutical storage, etc.) and access management should also take place at this time.

User groups will be asked to think about how they need and/or want the building to be accessed.

During normal business hours.

After normal business hours.

For special events.

User Groups will also be asked to think about who they need and/or want to be able to access the building when the building is:

Normally open.

Supposed to be closed.

University of Arizona										
Building KAS/SEC Door Types Matrix										
		Pin Pad		Request to	Auto					
Door		Proximity	Reader	Exit	Operator	Door	Electrified		Motion	Output
Type	Description	Reader	Only	(REX)	(ADO)	Contact	Hardware	Siren	Detector	Trigger
1	Pin Pad/Reader Access Door with ADO	Yes	No	Yes	Yes	Yes	Yes	Yes	No	No
2	Pin Pad/Reader Access Door without ADO	Yes	No	Yes	No	Yes	Yes	Yes	No	No
3	Door Schedule - Electrified Hardware	No	No	Yes	No	Yes	Yes	Yes	No	No
4	Monitor Door Status with Exit Shunt	No	No	Yes	No	Yes	No	Yes	No	No
5	Monitor Door Status Only	No	No	No	No	Yes	No	Yes	No	No
6	Reader for Type #3 Lock Control	No	Yes	No	No	No	No	No	No	No
7	Roof Access/Hatch or Tunnel Gate)	No	No	No	No	Yes	No	Yes	No	No
8	Area Monitoring	No	No	No	No	No	No	No	Yes	No
9	Elevator-Restricted Floor Access	No	Yes	No	No	No	No	No	No	Yes
10	Elevator-Call Button Activation	No	Yes	No	No	No	No	No	No	Yes

ATTACHMENT A

UNIVERSITY OF ARIZONA KEYLESS ACCESS SECURITY SYSTEM
RISER DIAGRAM

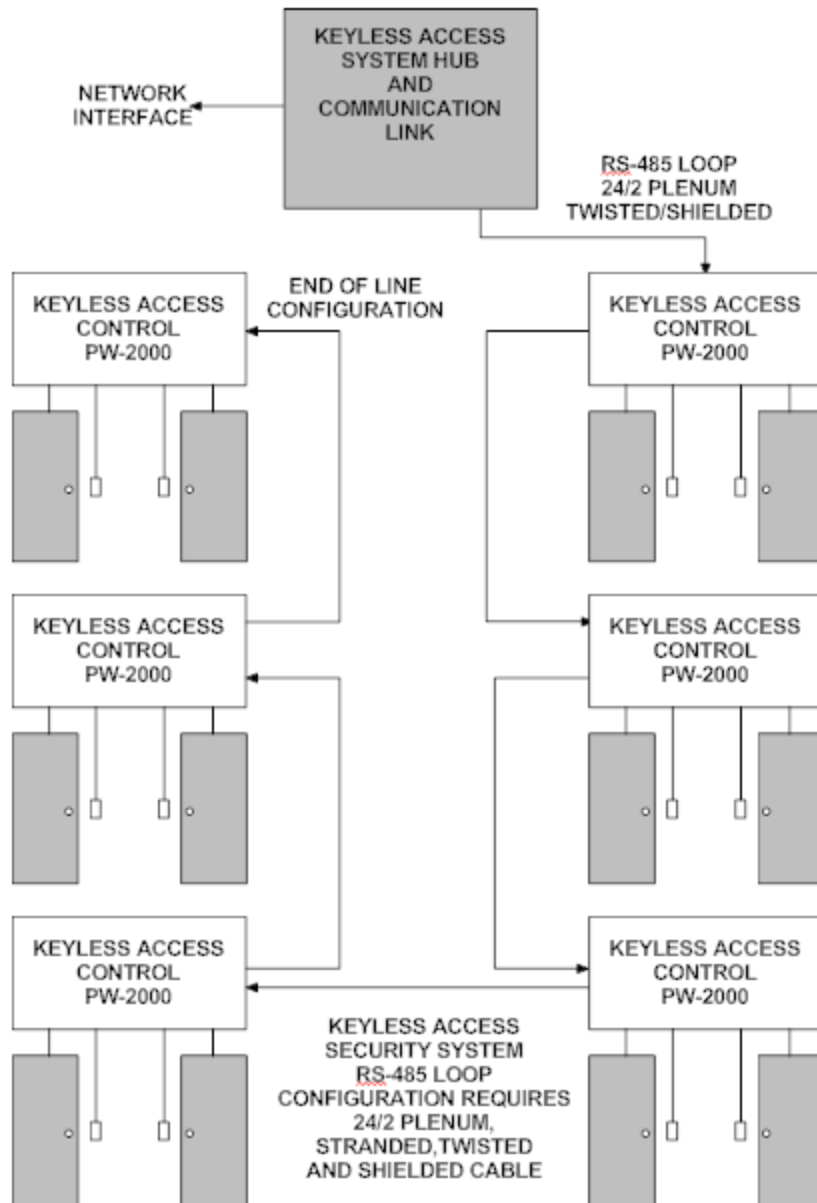

ATTACHMENT B

**University of Arizona Keyless Access System Control Panel
Layout and Power Requirements
Head End Equipment**

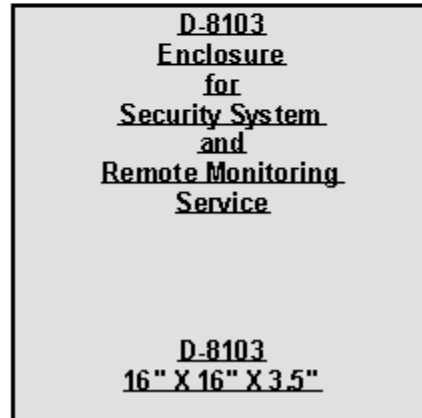
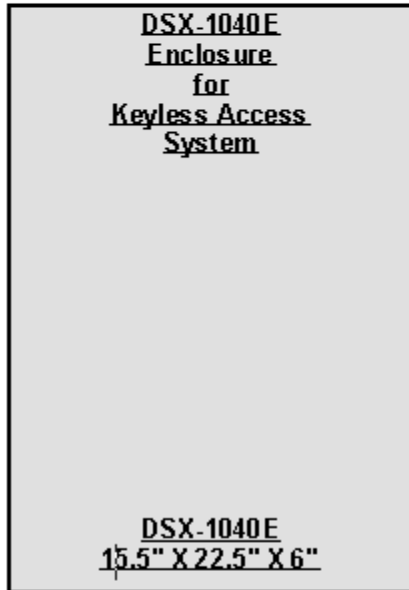
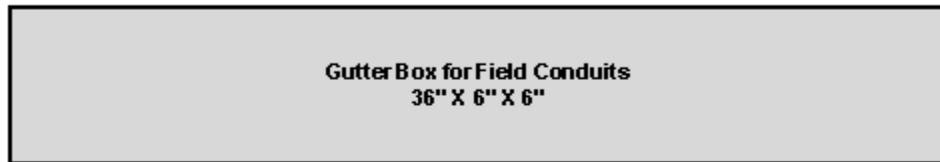

Two (2) Data Jacks
One (1) for Keyless Access
One (1) for Security





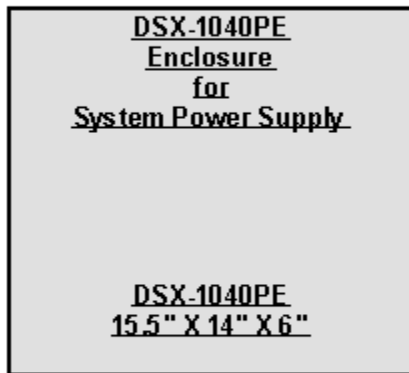











One (1) Duplex
Receptacle
Circuit to be identified in
the source panel.



120 VAC Circuit wired directly to
transformer inside of the power supply.
Circuit to be identified in the source panel.

ATTACHMENT C

University of Arizona Symbol List

<u>U of A Cat Card Access Reader and Locking Legend</u>	
<u>ADO</u>	<u>Automatic Door Operator</u>
	<u>Cat Card Access Reader</u>
	<u>Cat Card Access Bio Reader</u>
	<u>Door Position Switch</u>
	<u>Request to Exit Unit</u>
	<u>Door Ajar Audible Unit</u>
	<u>Card Access Control Panel</u>
	<u>Electric Strike</u>
	<u>Electric Lever with Power Transfer</u>
	<u>Magnetic Locks</u>
	<u>Exit Device with Power Transfer</u>
	<u>Removable Mullion</u>
	<u>Security Control Panel</u>
	<u>Security Key pad</u>
	<u>Elevator Control Panel</u>

ATTACHMENT D

**Architectural Drawing showing Card Readers
and Related Devices at Each Door**



ATTACHMENT E

**Architectural Drawing showing Card Readers
at Each Door Location**

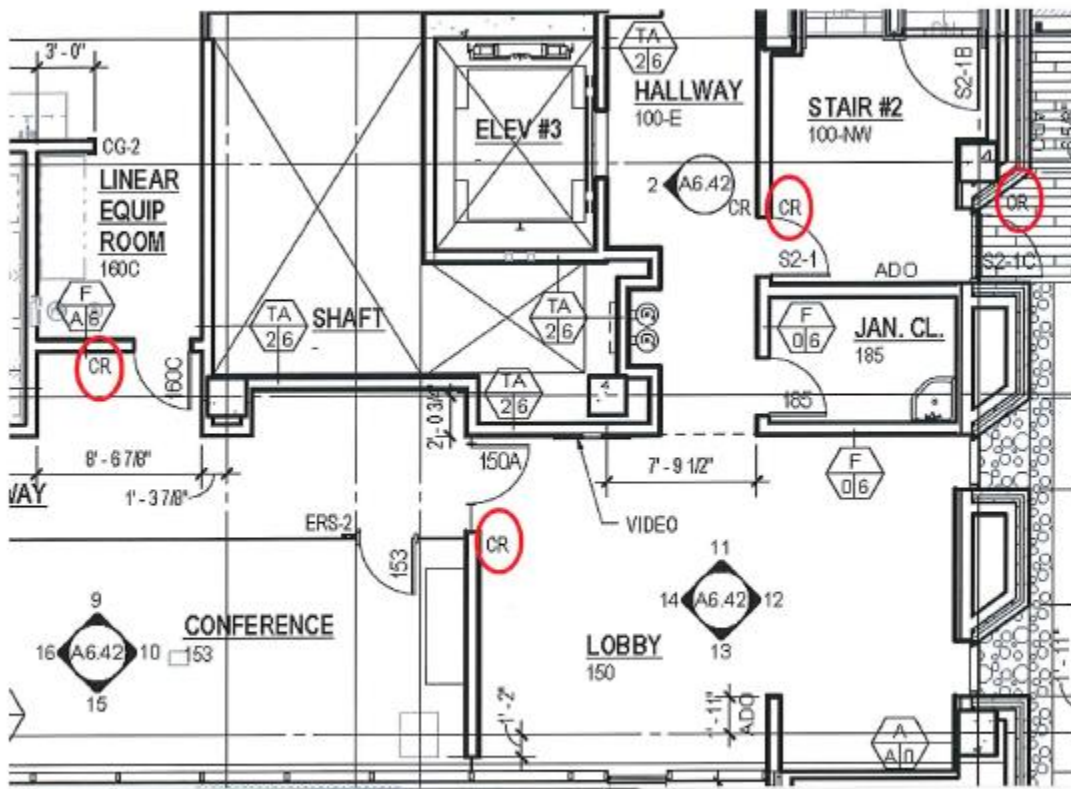

ATTACHMENT F

Electrical Drawing showing Card Readers
at Each Door Location and References to Individual Door Illustrations
for Conduit, Raceways and All Related Wiring

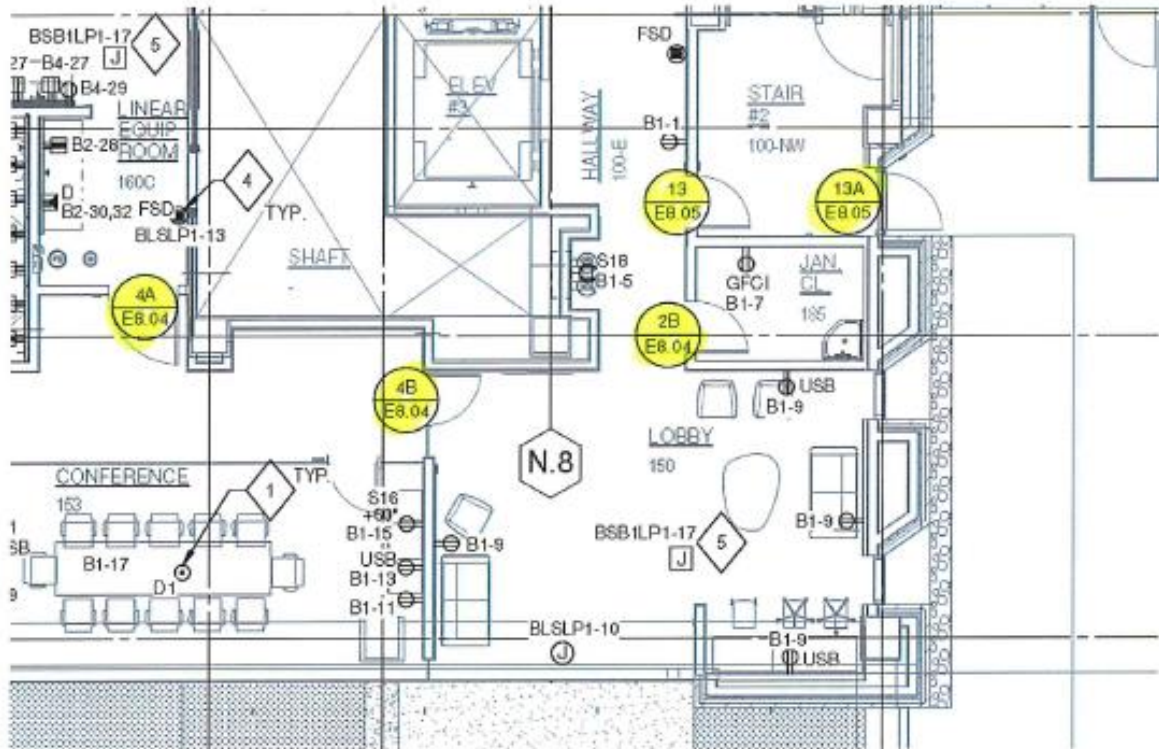

ATTACHMENT G

**Electrical Drawing showing Individual Door Illustrations
for Conduit, Raceways and All Related Wiring**

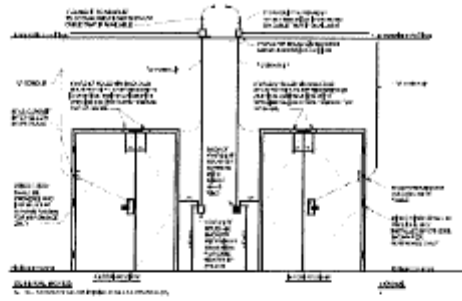

UNEVEN LEFT SWING DOOR HOLLOW METAL FRAME -
CARD ACCESS ELECTRIC RETRACTOR EXIT DEVICE
78

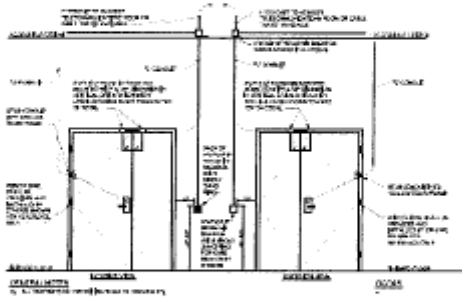

UNEVEN RIGHT SWING DOOR HOLLOW METAL FRAME -
CARD ACCESS ELECTRIC RETRACTOR EXIT DEVICE
79

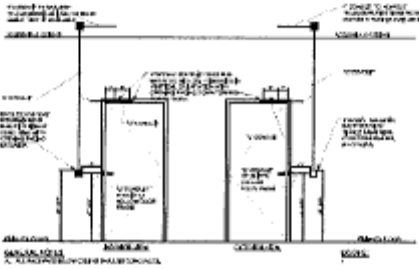

ATTACHMENT H

Door/Hardware Index

N = Opening Requiring Electrical Coordination

0 BASEMENT

Mark #	HWSet #	<i>N</i>	Mark #	HWSet #	<i>N</i>	Mark #	HWSet #	<i>N</i>
001	17	<i>N</i>	022D	38	<i>N</i>	052	47	
001-1	30	<i>N</i>	022E	38	<i>N</i>	053	67	
001-E	21	<i>N</i>	022F	39	<i>N</i>	054	61	
001-E1	41		024	26		055	66	
001-N	57		025	61		056	35	<i>N</i>
001-N1	57		026	24		056A	35	<i>N</i>
001-N1A	30	<i>N</i>	026A	69		058	01A	
001-NA	30	<i>N</i>	027	62		059	13	
001-S	41		028	62		060	57.1	
001-S1	19	<i>N</i>	029	24		061	01	
001-S2	07	<i>N</i>	029A	16		062	69	
001-W	19	<i>N</i>	030	25		063	43	
001-W1	20	<i>N</i>	030A	01		064	49	
001-W2	20	<i>N</i>	030B	01		064A	47	
001-W3	23		033	22	<i>N</i>	065	49	
002	33	<i>N</i>	033A	34	<i>N</i>	065A	47	
003	67		034	57		066	30.1	<i>N</i>
004	37	<i>N</i>	035	22	<i>N</i>	067	68	
012	69		035A	16		068	47	
013	75		036	65		069	47	
014	75		036A	55		070	69	
015	47		038	16		072	50	
016	66		039	34	<i>N</i>	073	51	
017	47		039A	16		074	51	
018	08		040	28		075	50	
019	21A		041	35A	<i>N</i>	076	72	
020	08		042	63		077	50	
020A	14		043	55		078	50	
021	26		044	62		081	50	
021A	69		045	66		082	53	
022A	39	<i>N</i>	047	72		084	53	
022A-1	39	<i>N</i>	048	55		K022	07	<i>N</i>
022B	39	<i>N</i>	049	47		51-B	11	<i>N</i>
022C	39.1	<i>N</i>	050	43		52-B	11	<i>N</i>
022C-1	39	<i>N</i>	051	47				

Project: U of A - Bioscience Research Laboratories (BSRL)	Control #: 143630	Print Date: Mar 27 2015 4:23PM EDT	
Company: Allegion, PLC	Version #: 5	Ver Date: Mar 27 2015 1:23PM EDT	Page 1 of 4

ATTACHMENT I

Bollard Pedestal Drawing

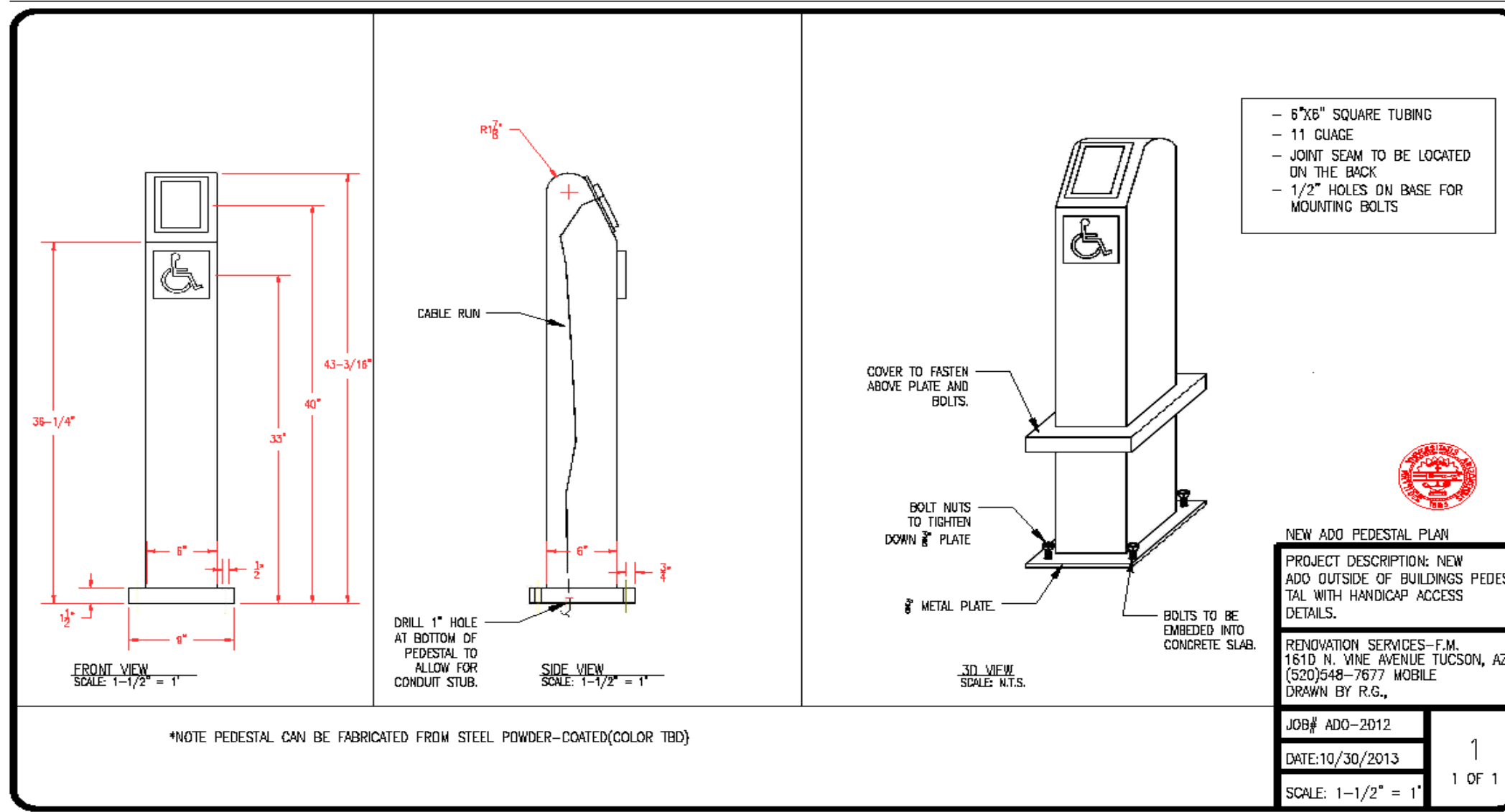

*NOTE PEDESTAL CAN BE FABRICATED FROM STEEL POWDER-COATED(COLOR TBD)

ATTACHMENT J

End of TAB C-6

TAB C-7

ROOM NUMBERING

Obtain building number, address, and room numbers from Real Estate Administration at 621-1813.

All drawings issued for construction shall contain and reference accepted room numbers so that electrical panels, telephone backboards, air distribution devices, as-built information, balance reports, etc. will not have to be cross referenced or revised after occupancy of the space.

Renovation projects shall maintain the same room numbering sequence which presently exists within the building. Obtain a current key plan for the building and fit new room numbers into the existing scheme and the following protocol. Secure acceptance of room numbers from Real Estate Administration before proceeding with any drawing schedules.

New buildings and additions shall generally adhere to the following room numbering protocol:

All room numbers shall consist of 3 primary digits.

The first digit shall identify the floor level. The ground floor is always level 1. Multiple basement levels will have to be treated as a special case.

The second and third digits shall be used to sequentially identify rooms on a floor level (01 to 99).

A fourth digit may be employed as a prefix to describe an independent building within a cluster or a sizable addition (i.e., N118).

From the elevator or main floor access; room numbers shall be assigned sequentially in a clockwise fashion left to right. Even numbers shall be used on the right hand side of the corridor and odd numbers on the left hand side. (When walking from the elevator or main floor access.)

Corridors shall be identified by a large even number and a suffix indicating the direction in which it runs (i.e. 500W).

Room numbering shall be assigned so as to allow for future room additions (i.e., spread the numbering system out so that infill numbers are available, based on available space).

An effort shall be made to maintain consistent room numbers for similar elements on each floor (i.e., if bathrooms are located in same area of each floor they should share common room number ending digits).

Rooms within a room (second order) shall be consecutively labeled alphabetically in a clockwise manner from left to right (i.e., 118A, 118B etc.). Additional rooms (third order) shall be sequentially numbered similarly (i.e., 118A1, 118A2 etc.).

Open vestibules and alcoves shall not be assigned permanent room numbers.

Scheduled door number references should match the room number to which it enters.

TAB C-9

SURFACE WATER DESIGN GUIDELINES

Intent

With the continuing development of the campus, the University strives to recognize the long-term inherent value of water by conserving, harvesting, capturing, and reusing it. Within a project's design process, surface water should be an influence on integrated site design promoting proactive solutions that are consistent with or exceed regulatory standards. Given current limited storm sewer and land capacities, combined with a historic reliance on existing streets for surface water conveyance, some of the mitigation of past and future surface water issues at the University of Arizona should occur on a project by project basis. In the interest of fulfilling this intent, two types of design criteria are noted below. The *General Surface Water Guidelines* address issues applicable to all projects while the *Specific Features Guidelines* inform the design intent of specific surface water elements.

General Surface Water Guidelines

- Preliminary siting studies for the project shall consider information related to the existing drainage conditions of the site, using the most recent campus-wide drainage study as a reference. The preliminary siting studies shall consider, at a minimum:
 - The existing site area and adjacent areas within 500 feet of the project, and include areas which may contribute surface water (watershed) to the proposed site.
 - The general area the site is within, for example, the campus historical core, North Campus, South Campus, etc.
 - Evaluation of existing landscapes, plant palette, formal, informal, historic, ornamental – introduced plants.
 - Evaluation of the contextual setting of the site.
 - Utility (below/at grade) corridors, emergency route, pedestrian and automobile electric cart core circulation routes.
 - Identified project building expansion and proposed expansion adjacent to the project site.
- Whenever possible, site development should not diminish the quality or increase the quantity or rate of surface water flow that leaves the site in its existing condition. Potential increased surface water flows should be mitigated on-site if possible.
- Wherever possible, site development should strive to reduce the quantity and rate of flow at or below the original natural condition of the site through the use of landscape swales and water harvesting.
 - Opportunities for water harvesting should be specifically discussed in conceptual narratives in early design stages. *"The City of Tucson Water Harvesting Guidance Manual, 2005"*, and *"Harvesting Rainwater for Landscape Use"* by Patricia H. Waterfall (University of Arizona Cooperative Extension), should be used as technical references.
- Site development should meet or exceed all applicable regulatory standards. The intent is to meet at a minimum COT stormwater standards (*Standards Manual for Drainage Design and Floodplain Management in Tucson, Arizona*), exceed them where possible, and to demonstrate innovative techniques for which the City may not have applicable standards.
- The *Surface Water Report* described in Tab B-11 of these Design and Specifications Standards and prepared for a project will be based on the format and technical standards of the COT (*Standards Manual for Drainage Design and Floodplain Management in Tucson, Arizona*) but will be tied to the hydrology model used for the most recent UA campus-wide drainage study. This model is consistent with but more detailed than COT models for the campus.
- All construction activities must be in compliance with the current version of the *University of Arizona Stormwater Management Plan*.

- Wherever possible, site development should occur in a way such that all flows exiting the project site remain in the current watershed sub-basin so as to not impact drainage patterns in adjacent watershed sub-basins.
- Flood Prevention: Proposed building ground floor elevations and any apertures into the building should be 1' or more above the 100 year flood plain (modifying this standard is strongly discouraged, but is an option if appropriate floodproofing can be demonstrated). Sunken access ways or patios leading to building levels below the natural grade of the site are not permitted when adjacent to a 100 year floodplain, and discouraged in other areas. Soil should be graded so that water drains away from the building at a minimum of 2%, subject to other site criteria, such as accessibility. Elevations of underground utilities shall be considered in the grading layout.
- Design and construction activity must be in compliance with the current *University of Arizona Stormwater Management Plan* submitted to Arizona Department of Environmental Quality.
- Site development must be done in a way to avoid the following conditions:
 - Ponding of a duration that may allow mosquito breeding
 - Ponding in access ways which may create a nuisance for pedestrians.
 - Ponding within 10' of building foundations (to prevent infiltration that may cause indoor mold or structural problems)
 - Any water catchment not draining within 24 hours
 - Retention facilities not draining within 12 hours.
 - Surface water that is wasted, e.g., by running down the street.
 - Surface water that is routed in a way which inappropriately distributes sediment or chemicals.
 - Channelized or concentrated water conveyed over sidewalks
 - Water running off of irrigated turf areas.
- A determination is to be made as to whether or not construction activity resulting from site development will disturb 1 acre or more. If 1 acre or more is disturbed a Storm Water Pollution Prevention Plan (SWPPP) will be required and an Environmental Protection Agency AZPDES Storm Water Construction General Permit must be secured. The University of Arizona department of Risk Management and Safety may be contacted for guidance in securing this permit and filing the associated EPA Notice of Intent (NOI).
- Storm Sewer Discharges:
 - Water discharged (e.g., storm water, condensate) from sources that must be pumped to a location for conveyance/disposal should not be directed to roadways/hardscape. Such discharges should be directed to planted areas except when the water quality would be detrimental to plants.
 - Storm and surface waters are not candidates for disposal in the Publicly Owned Treatment Works (POTW) or sewer system. Such disposal would constitute "hydraulic loading" and is considered a prohibited discharge by Pima County Industrial Wastewater Ordinance.
 - Manholes are not allowed in low lying areas and/or known watercourses to prevent waters from infiltrating through perforations in the manhole cover.
- Roof Drainage:
 - Roof drainage outlets and landscape surface materials must be designed to prevent landscape erosion.
 - Ponding within 10' of the building edge is prohibited.
 - Roof leaders/scuppers should be of a small enough diameter so as to divide roof runoff into a series of outlets with a low enough volume/velocity that will allow water to be harvested equally throughout the site (i.e., broken into small volumes for smaller basins/swales). Large diameter outlet pipes convey too much water at too high velocity to capture in small-scale landscape swales. Proper clean outs should be provided to allow necessary maintenance of smaller diameter pipes.
 - Bubbler boxes are strongly discouraged but may be used to dissipate the energy associated with larger volume rain leaders. In such cases, the bubblers should be located at least 10' from building foundations (see specific guidelines for bubblers below).

- Ancillary Water Sources Available On Or Near The Site:
 - Water sources such as mechanical condensate, process water, graywater, drinking fountain water, and other sources identified shall be considered as part of passive and active water harvesting systems.
 - Such water may be used, if deemed appropriate, for landscape irrigation, return to central plant for other uses, supplementing water for pools or water features, or other uses to be determined.
- Soils:
 - Testing
 - If possible, soils testing should be conducted at the time of or prior to preparation of the initial draft of the *Surface Water Report* that will be prepared for a project. Such reports should investigate not only structural characteristics but also percolation rates and agricultural soils analysis as it relates to plant growth. Agricultural soils analysis shall be prepared by a certified soils agronomist.
 - A soil percolation test is required after rough grading of major/regulatory detention and retention facilities to verify that site development activities have not negatively impacted percolation rates. If reduction in percolation rate is identified, mitigation may be required.
 - Subsurface preparation
 - Structural soils should be explored for use under large expanses of hardscape or other areas with limited percolation.
 - Soils beneath/adjacent to french drains, bubbler boxes, and other sub-surface structures should be over-excavated and replaced with an engineered soil designed to absorb or accept water.
 - Compaction
 - Soil beneath the bottoms of all water harvesting areas should be loosened to a depth of at least 18" prior to trenching and installation of irrigation lines.
 - Specified compaction required for buildings, streets, and other structures shall be maintained within specified distances around such structures. Beyond these compaction zones, soil should be loosened to a depth of at least 1' prior to planting within all landscaped areas.
 - All construction debris and waste material must be removed from the soil within landscape and basin areas.
 - Acceptable limits of compaction must be maintained through completion.
- Soil Grading: The finished grade of all landscaped areas should be recessed downward from adjacent paved surfaces to create water harvesting catchments. Maximum reveal at edge of pedestrian circulation paving shall be 1" to minimize the risk of injury. A 12" – 18" level shoulder area to the paved surface shall be maintained. The shoulder area shall have a 1% - 2% cross slope away from paving directed to water harvesting/basin areas.
- Ground Cover Materials:
 - Within areas conveying significant storm flows, ground surfacing should consist of a material that is able to withstand scouring. This includes hardscape paving, rock mulch, graded or sized rock, rip rap, fractured rock, and turf in some situations. Bare soil, decomposed granite, or other loose forms of mulch are not suitable for this application. Filter fabric placed with 12" minimum toe downs at edges shall be used under all rock, mulch, and rip rap within conveyance areas.
 - Rip Rap: Where required, utilize a rough, non-angular, weathered Catalina granite incorporating a spectrum of tan and gray colors. Alternatives will be considered based on justifications for the specific application (samples should be provided by design professionals). Filter fabric should be included under rip rap used for erosion protection in a conveyance channel, and any gaps in rip rap shall be fully filled with pea gravel or sized/graded rock that is swept in the gaps to prevent erosion.
 - Fine grades of decomposed granite should not be used within or adjacent to basins or water harvesting areas. Landscape areas which shed water rather than capture it should receive ½"+ crushed gravel with no fines, preferably with a mixture of sizes and some color variation to reflect the native desert surface.
 - The bottoms of landscaped basins should receive ¼" pea gravel or ½"-1" sized/graded crushed rock that has been washed to remove all fines or organic mulch.
 - Colors samples of all proposed rock types shall be submitted for approval.
 - Organic mulch is encouraged in locations where the vegetation, water collection, erosion, and slope characteristics make it appropriate.

- Turf, as a surface material in large regulatory basins, is only permissible when combined with a low-flow landscaped area which allows a majority of the turf to drain within a short time. It is preferable to utilize turf predominantly on the bottom rather than sides of large basins for ease of irrigation and mowing and to allow the turf to be watered by sheet-flow runoff. Based on project-specific considerations, turf panels may include a shallow retention catchment (6" or less) which shall include a prepared soil bed that will rapidly absorb retained rainfall. Extensive sub surface soil preparation will be required for turf in basins which collect greater volumes.

Specific Features Guidelines for Drainage and Water Harvesting

The following guidelines are intended to inform the design of specific surface water features when they are included in a project. Note that the Design and Specifications Standards (DSS) include specific guidelines for Water Features and for Wells in other sections. This section of the DSS includes guidelines for the following features:

- Water Storage Features
 - Water Harvesting Micro-Basins
 - Regulatory Detention / Retention Basins
 - Sumps
 - Dry Wells
 - French Drains and other Subsurface Structures
 - Structural Soil
 - Bubbler Boxes
 - Sidewalks
 - Storm Sewers
 - Area Drains
 - Infiltration Chamber
 - Permeable Paving
- Water Storage Features
 - Guidelines for all types of water storage cisterns:
 - Access points into the cistern must be secured for safety
 - Openings must be sealed or screened to prevent mosquito breeding
 - Light must be prevented from entering to prevent biological growth
 - A method for using/distributing the water must be designed into the system.
 - Projects which include cisterns are encouraged to explore all available sources of water to be captured, including rainwater, condensate, and other sources unique to the location.
 - Underground water storage cisterns:
 - Underground cisterns may be used where a very large volume of water is being stored or where there are no appropriate surface level sites available.
 - Water stored in underground cisterns may be allowed to infiltrate or bleed off, although the preference is for this water to be stored and utilize for landscape irrigation. In such cases, pumping and filtering mechanisms must be included.
 - Above ground exterior water storage cisterns:
 - Above ground cisterns are appropriate for smaller volumes of water and where the storage structure may be appropriately integrated into the landscape.
 - Water Harvesting Micro-Basins
 - General Guidelines for Design of Water Harvesting Micro-Basins:

- The depth of a micro-basin should be sized according to the anticipated volume of water that will enter the basin, taking into consideration whether the basin will only collect water falling on the basin area or if it will be intercepting flows from adjacent watersheds.
 - The edge of any ponding within microbasins should be 10 feet from building foundations. Closer placement may be possible with the approval of a soils professional and may include structural soil backfill with protective liner at the foundation.
 - Micro-basins should be designed so that water infiltrates the soil within 12 hours.
 - Unpaved or planted areas should be sunken below the grade of adjacent hardscape to create micro-basins wherever possible. Pedestrian circulation should be designed to discourage cutting across basins so as to avoid compaction, erosion, and damage to plants.
 - Conveyance swales should incorporate check dams and/or nested micro-basins to slow and harvest water and trap sediment.
 - Water should be harvested and slowed near its source to avoid the need for larger catchments downstream.
 - The *City of Tucson Water Harvesting Guidance Manual* should be used as a technical reference.
 - The design/placement of micro-basins shall “co-evolve” with the planting design so that plantings will take maximum advantage of harvested water.
 - In larger, open, landscape areas not constrained by adjacent hardscape, a series of interconnected small basins (5’ to 15’ wide) terraced into the landform should be included. Additional smaller basins which correspond to planting patterns are generally preferred over fewer large basins. Where included, a concept diagram for such interconnected basins is to be provided in the Surface Water Report.
 - The arrangement, contouring, sequence, and form of micro-basins should take on a natural character unless the form of the adjacent hardscape, or an approved overarching artistic concept, suggests more formal or otherwise less-organic forms are appropriate. Earthworks within small, narrow areas should generally include simple, function forms due to the limited area to vary the pattern.
 - Plants selected for use in microbasins shall have compatible water needs. Other considerations shall include sun exposure, maintenance requirements, shape, form and aesthetics. Certain plant forms may work better in informal vs. formal planting designs. Consideration shall be given to the area of campus (historical core, AHSC, etc.) when selecting plants. Plants shall be used to create a seamless transition from new improvements/building projects and the existing adjacent landscape. Plants with differing water needs shall be irrigated and controlled separately. Irrigation system shall be capable of monitoring plant water needs through the use of soil moisture gauges and weather station data.
- Drawing Standards for Water Harvesting Micro-Basins:
 - Micro-basin details shall be developed and referenced in all planted or non-paved areas on both the landscape and civil drawings. Below are standards to be used in preparing required drawings which describe in graphic and text form water-harvesting micro-basins.
 - Plans:
 - A 10’ setback line from buildings is to be shown on the grading plan indicating the limits of allowable ponding.
 - The design of paved or circulation areas should, wherever possible, slope the hardscape/surface toward micro-basins. All paving adjacent to micro-basins shall be labeled with arrows indicating a slope toward the micro-basins.
 - RipRap shall be indicated on appropriate drawings for micro-basin slopes where required.
 - The level, flat bottoms of micro-basins shall be shown on civil/grading *and* planting plans with a hatch pattern. Spot elevations shall be shown on the grading plan to indicate the elevation of the flat bottom area.
 - The location of any french drains within micro-basins must be indicated on civil/grading plans.
 - For micro-basins accepting water from adjacent watersheds/basins or overflowing into adjacent watersheds/basins, the location of inlets/outlets/spillways shall be indicated on the civil/grading plans along with flow arrows. Rip rap needed for erosion protection shall be shown at inlets/outlets. Volume calculations shall be provided where necessary.

- Details/Notes: A detail or series of details with accompanying notes that reflect the following standards for micro-basins shall be prepared.
 - The edge of ponding in micro-basins should be a minimum 10' setback from any building.
 - Adjacent to hardscape, there should be a minimum flat area 12" wide of compacted soil before beginning the sideslope of a micro-basin.
 - Basin sideslopes should vary, but be no greater than 3:1. Variation in slope is desirable to create undulations in the form of basins.
 - Sideslopes and berms which form the edge to micro-basins should be compacted.
 - Slopes steeper than 4:1 may require rip rap depending on surface flows, erosion potential, and circulation patterns.
 - Micro-basin bottoms should be level, with flat areas as large as possible while not causing sideslopes to exceed 3:1 .
 - When proposed planting areas are bound by hardscape at different elevations, micro-basins are to be included for these planting areas as long as a catchment area can be achieved which is at least 1' wide (flat bottom) by 2" deep (while not creating sideslopes steeper than 3:1).
 - Micro-basin flat bottoms shall be excavated/loosened to a depth of at least 18" beneath the finished grade of the basin bottom. This shall be done at the time of rough grading and prior to trenching for irrigation lines. Loosened soil should be re-compacted beneath new tree root balls. Note that by following all guidelines in this section, basin bottoms should be far enough away from fixed structures so that minor settling of the soil should not have any negative impacts.
 - French drains are encouraged within the bottoms of micro-basin to promote infiltration of water when contributing flows from adjacent watersheds warrants a greater holding capacity. Micro-basin french drains must be longer than they are deep and the bottom of the french drain must be no more than 3' beneath the basin bottom so as to keep the water within the soil root zone of plants. If french drains are proposed, discrete details must be prepared for them.
 - For a micro-basin accepting flows from adjacent watersheds, the basin bottom should generally be no deeper than 18" below the basin spillway or rim (greater depth is acceptable if there is an outlet at 18" or less). For a micro-basin only receiving rain falling directly within it, typical depths should range from 4" to 8".
 - Rip rap is to be included for erosion protection at spillways.
 - The bottoms of micro-basins should receive ¼" pea gravel, or ½"+ crushed gravel that has been washed to remove all fines, including gravel dust. Micro-basin bottoms may also receive organic mulch.
 - If a series of small interconnected or terraced basins are included in the design, the horizontal, vertical, and flow relationship between them should be documented in one of the details.
 - Typical planting details (shrub, tree) are to be shown in the level bottom and side slope terraces in the micro-basin details, with appropriate grade transitions shown. For trees, indicate the rootball sitting on undisturbed native soil with top of rootball level with a terrace 4"-12" above the finished flat bottom of the basin. Indicate a mulch layer within this terrace which does not bury the trunk. In no circumstances shall there be a low area for water to pond directly around the trunk of the tree.
 - Excess soil removed from planting holes must not be spread or disposed of within micro-basins.
 - Include a note that all micro-basin grading must be complete and inspected prior to planting and again prior to application of mulch.
- Regulatory Detention / Retention Basins
 - Mitigation of Regulatory Storm Flows with Surface Basins
 - Basins should be designed for multiple-use (i.e. drainage, active and passive recreation, landscape aesthetics, and circulation). Basins should be designed as a collaboration between the project Landscape Architect and the Civil Engineer, with input from other team professionals. The basic land forms and site characteristics should be laid out in concept form by the Landscape Architect. The preliminary basin design will be approved by the University prior to detailed hydrologic modeling by the Civil Engineer.
 - Smaller non-turfed basins can be used for passive type use such as sitting areas. Site amenities such as benches can be built in or incorporated in the design of the basin area.

- Universal access should be provided to basins to the greatest extent possible using functionally and visually integrated structures.
 - Flows from land uses which are likely to generate pollutants (such as parking lots) should route water in a way that isolates the first flush runoff in discrete catchments so as to limit the spreading of contaminants and to make future clean up easier.
 - Routing of flows between micro-basins or larger basins should be done in a way to slow flows for increased absorption and reduced erosion.
 - The following characteristics should be designed for turf basins to insure quick draining into a landscaped low-collection area.
 - Minimum bottom slope of 1% for turf
 - Sub-surface should be prepared to a minimum of 18" below imported soil for the turf.
 - Low-flow collection areas should not be in the low point of turf. The lowest turf areas should drain to landscaped collection areas, allowing the turf to dry out as soon as possible following the rain.
 - Landscaped (non-turf) basin bottom surface: Round pea gravel or ½" to 1" sized/graded crushed rock is to be used in basin bottoms.
 - Basin form: Single-use storm water catchment basins typically derive their form based on simplified patterns which are easy to translate into a storage volume, and are therefore easy to model. Such forms are generally incompatible with the type of multi-use open space basins desired on the University campus. Therefore, basin side slopes should vary (i.e., the horizontal distance between contours should vary) in response to aesthetic and multi-use design objectives of the project. During concept design, water storage calculations corresponding to desired mitigation goals are to be converted into gross volumetric dimensions and then provided to the project Landscape Architect for use in designing the basin form. The resulting form will then be modeled by the project Hydrologist in order to provide feedback about adjustments which may be needed in the size/form of the basin to achieve storm mitigation goals. Several such iterations of design refinement may be required to achieve a satisfactory result.
 - Basin side slopes: Side slopes should be a maximum of one unit of vertical change for every three units of horizontal change.
 - Retention basins must demonstrate ability to drain within 12 hours, based on soil tests.
 - Low flow metering/outletting to bleed off detained water should be proposed for basins which percolation testing has shown will not drain within 12 hours (otherwise a plan must be proposed for ongoing pumping).
 - Weirs / outlets / inlets should be designed as integral elements of the landscape as opposed to purely functional conveyance structures
- Mitigation of Regulatory Storm Flows with Subsurface Storage tanks:
 - Subsurface storage tanks include various systems to hold water underground and are conceptually similar to underground cisterns (see above), with the difference being that subsurface storage tanks are sized to accommodate or mitigate flow volumes corresponding to major storm events.
 - Guidelines noted above for underground cisterns apply to subsurface storage tanks.
- Sumps
 - Water collected in site/building sumps: Sumps which collect water running off into courtyards or other non-draining areas should be designed to pump the water into landscaped areas configured for water harvesting, or into an adjacent irrigation system. Sump water which may contain unique pollutants, sediments, or other elements making it unsuitable for irrigation may require special provisions for disposal.
 - Discharge of sump water shall not be to surface streets or storm sewers.
 - Dry wells
 - Drywells are defined by the Arizona Department of Environmental Quality (ADEQ) as: "A drywell is a bored, drilled, or driven shaft or hole with a depth that is greater than its width and that is designed and constructed specifically for the disposal of stormwater (Arizona Revised Statutes (A.R.S) 49-331(3)).
 - Drywells shall be considered only as a last resort for the distribution or disposal of surface/storm waters.

- French Drains and other Sub-Surface Structures
 - French drains are encouraged in larger volume harvesting/detention areas where adequate soil percolation may be in question.
 - French drains must be wider than they are deep.
 - Rock backfill in drains may be wrapped with filter fabric depending on the intent of the drain.
 - Perforated pipe may be placed in the trench to facilitate the movement of water throughout the length of the drain.
 - French drains can be routed through planted areas to maximize using rainwater to supplement irrigation.
 - The intent of French drains is to dispose and disperse water throughout soil within the root zone.
 - The bottom is to be no deeper than 10' beneath the finished surface grade. A maximum depth of 3' is desirable in planted areas so as to keep water within plant root zones.
 - Other sub-surface structures intended to disperse water into the soil root zone, such as infiltration chambers shall be evaluated on a case-by-case basis.

- Structural Soil
 - Structural soil is a specialize soil mix involving a coarse aggregate, organic and non-organic soil components, and a binder which creates a structural sub-grade sufficient for heavy load paving, while also providing the air and water flow needed within the soil for root growth.
 - Structural soil shall be utilized to increase the viable root growth zone for trees planted within large expanses of hardscape.
 - Water collected/shed from adjacent hardscape shall be directed into the structural soil via surface flows to planter cut-outs, area or roof drains which empty directly into the soil matrix, or through permeable pavement.

- Bubblers boxes
 - Bubbler boxes are designed to overflow, therefore, they do not meet the definition of a drywell (they are for conveyance, not disposal).
 - All bubbler boxes shall be constructed to have porous, draining bottoms, and the soil beneath bubbler box units must be prepared in such fashion to support percolation.
 - All bubbler box systems shall be constructed to drain their full volume with 24 hours.
 - Bubbler boxes shall be designed to minimize clogging, silting, and calcification, and shall be easy to clean.
 - Bubbler box systems shall drain into one or a combination of recessed turf areas, landscaped water harvesting microbasins, or areas of structural soil.
 - The design shall be configured to allow pumping if needed over the long term. In the event pumping systems are required, pumping durations shall be to be limited so as to not impact landscapes.

- Sidewalk Scuppers/Trench Drains
 - Water from roof drainage outlets, channels and swales must not be routed across sidewalks.
 - Scuppers, drain pipes or trench drains should be used to convey this water beneath walks or paths. Provide rock mulch or rip rap at inlet and outlet as needed to control erosion.
 - It is preferable to route water under walkways in a way that does not interrupt the continuity of the walkway surface material (as happens when steel plate is used). If walkway surface material is interrupted, trench drains may be used as a design element in the hardscape.
 - Sheet flow conveyance across sidewalk surfaces is to be minimized wherever possible by capturing as much runoff as possible in adjacent water harvesting microbasins.

- Storm sewers
 - Campus storm sewers are to be designed using City of Tucson standard details unless alternative direction is provided.

- Area Drains
 - Drains collecting water within confined spaces which do not discharge flows via the natural grade shall be constructed so as to accommodate all flows which may reasonably be expected to enter the drain system during a 100 year storm.

- This shall include consideration of flows originating beyond the extents of the immediate project (e.g., an adjacent 100-year floodplain) which may enter the immediate area during a large storm event.
- Infiltration Chambers
 - Infiltration chambers are recommended in situations where surface catchment is limited or localized flooding is likely due to lack of a natural outflow path. Chambers should be designed to percolate water into the soil root zone.
- Permeable Pavement
 - Permeable paving includes a variety of surfaces which withstand pedestrian and/or vehicular loads and wear, and permit infiltration of water and air into the subgrade.
 - Permeable paving must be installed with an appropriate subgrade which will allow absorption and/or draining of subsurface water to another location. If there is vegetation adjacent to the permeable paving, a Structural Soil subgrade should be used to allow water absorption into the soil. If there is no adjacent vegetation which would benefit by the water being deposited in the soil, a sub-surface drain system should be included which moves the water to adjacent planting areas.

References:

¹*City of Tucson Standards Manual for Drainage Design and Floodplain Management in Tucson, Arizona 1989*

²*Stormwater Detention Retention Manual for Pima County Department of Transportation & Flood Control District and the City of Tucson, 1987*

³*City of Tucson Water Harvesting Guidance Manual, 2003*

⁴*University of Arizona Master Drainage Study, 1997*

⁵*University of Arizona Stormwater Management Plan*

⁶*Harvesting Rainwater for Landscape Use, 1998*

TAB C-10

TREE PRESERVATION, PROTECTION, & SALVAGE GUIDELINES

Intent

The University values its more than 7,000 campus trees for their shade, beauty, history, and architectural importance. The UA Campus Arboretum has been established to document, monitor, and sustain the University's collection of trees.

Trees contribute to campus by creating intellectual open spaces and by providing for climate mitigation, carbon sequestration, and storm-water uptake. As the University strives to become more environmentally sustainable, trees lower the "heat island" effects of buildings and pavement and reduce costs for building climate control. Campus open space objectives include increasing campus shade by expanding the percentage of tree cover.

To support the goal of sustaining the University's tree collection, campus projects must include analysis of existing trees during the design process. Site analysis guides the development of a plan to preserve, protect or salvage trees during construction. Resources to assist with the assessment plan include the UA Campus Arboretum's Tree Preservation Table, available at the Department of Planning, Design and Construction, and the GIS campus tree map on the Campus Arboretum's web site: <http://arboretum.arizona.edu>.

General Procedures

- Identify trees in the Campus Arboretum Tree Preservation Table and GIS base map by name and location within the project site. Identify unique characteristics of the trees where possible, i.e. Heritage Trees, one of a kind on campus or in the state. Field verify tree identity and location.
- Review proposed project site for impacts to existing trees and prioritize trees for salvage. Collection of additional data (i.e. size, quality) may be necessary.
- Develop a tree assessment plan. Determine and identify the status of existing trees. The status assigned for existing trees on site will dictate the corresponding action to be taken in the following descending order of priority:
 - Retain in place and preserve during construction,
 - Salvage and replant in another campus location (identify new site),
 - Salvage, hold and replant on site,
 - Replace specimen with new planting on site,
 - Propagate tree for planting in another campus location (identify new location),
 - Remove tree
- Prioritize tree salvage and preservation for tree value, budget and aesthetic considerations. Identify responsibilities and funding sources for tree preservation and salvage.
- Review tree assessment plan with the project design team, Campus Arboretum Director, Campus Landscape Architect, and Facilities Management Grounds Services. Determine status for all existing trees.
- Monitor tree preservation, salvage, storage, and replanting during construction for compliance with specifications.
- Consideration to be given to the time of year when salvage and transplanting activities are to be undertaken.

End of Tab C-10

TAB C-11

ACCEPTABLE INDOOR AIR QUALITY PLANNING, DESIGN, AND CONSTRUCTION CRITERIA

CODES AND STANDARDS

- ANSI/AIHA Z9.5-1992: American National Standard for Laboratory Ventilation
- ASHRAE Standard 62-1999: Ventilation for Acceptable Indoor Air Quality, 1999
- The University of Arizona Manual of Design and Specification Standards (MDSS)
- SMACNA: IAQ Guidelines for Occupied Buildings Under Construction, First Edition, November, 1995

A. DESIGN

Purpose: To facilitate communication and improve understanding of indoor air quality issues among members of the design team and between the design team and the University and provide the basis for evaluating indoor air quality issues and the performance of the HVAC system during the commissioning process.

1. Identify and document all heating, ventilating, and air conditioning (HVAC) system design requirements, assumptions, and criteria. The following information shall be provided:
 - 1.1 Indoor design conditions for each building space:
 - a. Temperature
 - b. Relative humidity by season
 1. Maximum space humidity during all seasons: 50%
 - c. Pressure relationship between adjacent areas
 - 1.2 Outdoor design parameters:
 - a. Dry bulb and wet bulb temperatures
 - b. Relative humidity
 - c. Prevailing wind direction by season
 - 1.3 Building space information:
 - a. Type
 - b. Occupancy densities
 - c. Activities
 - d. Use patterns
 - 1.4 Internal loads for each building space:
 - a. Lighting
 - b. Equipment
 - c. People
 - d. Infiltration
 - e. Any special or unusual electrical, thermal, or moisture loads
 - 1.5 Any odorous or hazardous pollution sources for which additional measures, e.g., local exhaust, additional dilution ventilation, are required.

- 1.6 Criteria utilized to determine outside air requirements for each building space.
 - a. Minimum outside airflow rates shall be clearly indicated on design drawings.
 - 1.7 Classification of air assumptions for exhaust and recirculation air streams shall be in accordance with Appendix A.
 - 1.8 Air cleaning and filtration efficiencies and filter area.
 - a. Filter area shall be clearly indicated on design drawings.
 - 1.9 Means by which outdoor air quality has been assessed and outdoor air contaminants of concern (if any) and air filtration requirements determined to establish outdoor air intake location(s).
 - a. The building site shall be surveyed for sources of contaminants (health, odor, or sensory irritation contaminants).
 - 1.10 Criteria used to determine locations of air devices (e.g., supply, return, exhaust, etc.) to ensure proper dilution and mixing of air within each building space.
 - 1.11 Means by which and locations where outdoor air can be measured and balanced.
 - 1.12 Means by which temporary exhaust can be provided in the future to control strong source contaminants during shell space construction. For further information, refer to Appendix B.
 - 1.13 Applicable codes, standards, regulations, etc.
 - 1.14 Narrative describing the design and operation of the HVAC systems during occupied and unoccupied periods.
 - 1.15 Description of HVAC system control sequence of operation and identification of control system setpoints.
 - 1.16 Minimum and maximum flow rates for terminal units.
 - 1.17 Description of building envelop construction, including locations of vapor and air retarders.
 - 1.18 HVAC calculations, including cooling load, heating load, and exhaust flow rate calculations.
2. Integrate prudent design principles and features as indicated in the following paragraphs.
- 2.1 Locate outdoor air intakes away from known sources of contaminants, including, but not limited to, exhaust and vent outlets, plumbing stacks, emergency generator exhaust stacks, loading dock areas, flue stacks, and areas where people might congregate to smoke. For further information, refer to Appendix C.
 - a. Preferred location of outdoor air intakes is above roof level.
 - b. Outdoor air intakes should preferably not be located at ground level.
 - 2.2 Locate exhaust and vent outlets away from operable windows and doors and property line. For further information, refer to Appendix D.
 - 2.3 Bird screens shall be located over outdoor air intakes.
 - a. Bird screens shall be constructed of galvanized or stainless steel. Bird screens shall be ¼-inch mesh.

- b. Bird screens shall be accessible for cleaning.
- 2.4 Outdoor air intakes shall be protected from rain entrainment by louvers, mist eliminators, or rain hoods. For further information, refer to Appendix E.
- 2.5 Recirculation of air (for further information, refer to Appendix A):
- a. Recirculation of Class 1 air is allowed.
 - b. Recirculation of Class 2 air within the same room is allowed; recirculation of Class 2 air is allowed in other rooms if particulates are filtered or the air is sufficiently diluted with Class 1 air.
 - c. Class 3 air can only be recirculated within the same room.
 - d. Class 4 air can be exhausted or recirculated if the air is filtered to Class 2 air criteria.
 - e. Class 5 air must be exhausted.
- 2.6 Provide access doors to the following components for inspection and cleaning purposes: outdoor air intakes or plenums; upstream and downstream surfaces of cooling and heating coils; air washers; evaporative sections and coolers; other heat exchangers; air cleaners; drain pans; fans, filters, damper sections, humidifiers; and air flow measuring stations (other than unit flow sensors).
- a. Access doors shall be factory-fabricated, readily openable, and airtight.
 - b. Access doors shall be clearly indicated on the design drawings.
 - c. Access doors shall be clear of all obstructions and provide full access.
 - c. Air handling unit access doors shall be full man-doors or as large as equipment will allow.
 - e. Ductwork access doors shall be as large as ductwork will allow. If possible, ductwork access doors shall have a minimum size of 18-inches by 18-inches; 24-inch by 24-inch access doors shall be provided where possible. Hard ceiling or wall access doors shall be fire-rated and have a minimum size of 24-inches by 24-inches.
- 2.7 Air handling equipment shall be designed for no water droplet carryover. The MDSS requires air-handling equipment to have draw-through cooling coils having a maximum face velocity of 400 fpm properly and evenly distributed across the face of the cooling coil.
- 2.8 Drain pans shall be pitched towards the drain and shall be appropriately trapped. For further information, refer to Appendices F and G.
- 2.9 No internal exposed thermal insulation is permitted except as allowed by the MDSS.
- a. Supply ductwork shall be wrapped on its outside surface with thermal insulation in accordance with the MDSS.
 - b. Internal exposed thermal insulation shall not be installed in medical areas, clean rooms, or high velocity ductwork.
 - c. Internal exposed thermal insulation may be used in acoustically critical applications where the University's written permission has been obtained.
 - d. If permitted, internal exposed thermal insulation shall be elastomeric closed cell, cleanable, non-biodegradable, impermeable to water and moisture, and secured with welded pins and non-flammable adhesive. Internal exposed thermal insulation must have metal nosing or sleeves over leading edges at fan discharge, around access door openings, and at any point where the insulation is preceded by internally uninsulated duct. Internal exposed thermal insulation shall be kept away from intake screens, mist eliminators, louvers, and rain.
- 2.10 Air handling equipment and ductwork shall not be constructed of porous or semi-porous materials, e.g., concrete masonry units (CMU) or gypsum wallboard (GWB).
- 2.11 Potable water shall be used in direct evaporative humidifiers, air washers, and evaporative coolers.

- 2.12 Provide humidification only when absolutely necessary or when it is a special project requirement.
 - a. Utilize steam-to-steam-type humidifiers only.
- 2.13 Provide continuous water bleed or automatic periodic drain combined with chemical water treatment to control scale and microbial growth in air handling systems designed to recirculate water from an open storage tank or sump of an evaporative cooler, air washer, or evaporative section of air handling equipment.
 - a. If water treatment chemicals are used they shall not enter the air stream or must be acceptable for use in evaporative equipment and approved for this use by the University's Risk Management & Safety Department. To determine the acceptability of water treatment chemicals, contact the National Antimicrobial Information Network at 1-800-447-6349.
- 2.14 Filters shall be selected as appropriate for the application. For further information, refer to Appendix H.
 - a. Filters for air handling equipment whose flow rate exceeds 4,500 cfm shall have a minimum sixty percent (60%) efficiency pre-filters and final filters with 80-85% minimum efficiency when passing a three (3) micron particle.
 - b. Filters for all other air handling equipment shall have a minimum efficiency of sixty percent (60%) when passing a three (3) micron particle.
 - c. Filter area shall be based on 400 fpm face velocity.
 - d. Filter rack shall be constructed to allow no bypass of air.
- 2.15 Supply ductwork located in a return air plenum, chilled water supply and return piping, and domestic cold water piping below 55 degrees F shall be properly insulated to prevent condensation from forming. For further information, refer to Appendix I.
- 2.16 Insulation subject to damage or a reduction in thermal resistivity if it were to become wet shall be enclosed in a vapor retarder.
- 2.17 Outdoor air intake controls shall maintain no less than ninety percent (90%) of the design outside air flow rate at all times. For variable air volume (VAV) systems, refer to Appendix J.
- 2.18 Air handling system controls shall include an "optimum start-stop" provision to ensure that acceptable temperature, humidity, and ventilation is provided prior to daily space occupancy. For further information, refer to Appendix K.
- 2.19 Carbon dioxide (CO₂)-based demand control ventilation may be used, but must have a minimum outdoor air flow rate to control building sources. Refer to ASHRAE Standard 62-1999, paragraph 6.3.1 and Appendix D, "Rationale for minimum Physiological Requirements for Respiration Air Based on CO₂ Concentration" to determine the minimum outdoor airflow rate per person required for a specified CO₂ concentration.
- 2.20 Construction of the building envelope shall comply with all applicable code requirements relating to the control of water and water vapor penetration, air filtration, and entry of radon and other soil gases.
- 2.21 HVAC systems shall be designed to provide at all times no less than the minimum total amount of outdoor air required for ventilation by Table 2 of ASHRAE 62-1999.

- 2.22 Zone minimum airflow rates shall provide minimum outdoor air ventilation airflow rates during space occupancy.
- 2.23 Mechanical rooms shall not be used as air plenums. Air routed through mechanical rooms shall use hard ductwork only.
- 2.24 Utility fans serving fume hoods shall have a 3,000 feet per minute minimum discharge velocity in a vertically upwards direction and shall discharge at a minimum of ten (10) feet above the adjacent roof line. For further information, refer to ANSI/AIHA Z9.5.
- 2.25 Direct evaporative cooling may be used in air handling equipment only after the University's written permission has been obtained.
- 2.26 Direct evaporative cooling equipment:
 - a. Must limit space relative humidity to less than fifty percent (50%).
 - b. Must have no filter bypass.
 - c. Must be completely accessible, both upstream and downstream, for inspection and cleaning.
 - d. Must have no water droplet carryover. Manufacturers' recommendations for maximum allowable face velocities must be followed.
 - e. Must have filters upstream that have a minimum sixty- percent (60%) efficiency when passing a three-(3) micron particle.
 - f. Must have a water treatment system to prevent scale formation and anti-microbial growth that utilizes potable make-up water, blowdown, and water treatment chemicals.
 - g. Must use water treatment chemicals that do not enter the air stream or must be acceptable for use in evaporative equipment and approved for this use by the University's Risk Management and Safety Department. To determine the acceptability of water treatment chemicals, contact the National Antimicrobial Information Network at 1-800-447-6349.

B. CONSTRUCTION

Purpose: To ensure that work procedures and appropriate controls are utilized to minimize degradation of building indoor air quality during construction, renovation, remodeling, and maintenance activities.

1. Initial Planning

- 1.1 The party responsible for construction, renovation, remodeling, and/or maintenance activities must prepare a plan that addresses how indoor air quality issues will be handled during these activities.
 - a. If the activity only involves University staff, the responsible party will be a University department, e.g., Facilities Management, Facilities Design and Construction, Space Management, etc.
 - b. If the activity involves an outside consultant, the responsible party will be the consultant.
 - c. The University department or consultant shall contact and consult with the University's Risk Management & Safety Department during plan preparation.
 - d. The plan must be approved by the University's Risk Management and Safety Department prior to the beginning of construction.
- 1.2 The plan shall include the following information at a minimum.
 - a. Identification of potential work-related airborne contaminants, e.g., dusts and odorous or hazardous substances.
 - b. Identification of how contaminants may spread through the building.

- c. Identification of how building occupants will be affected by the spread of such contaminants.
 - d. Identification and selection of feasible, specific control measures to keep dusts and odorous and hazardous substances out of occupied areas. These measures could include work area containment, modification of HVAC operation, reduction of emissions, intensification of housekeeping, rescheduling of work hours, moving occupants, defining re-occupancy criteria, etc.
- 2. Isolation of major construction, renovation, remodeling, and maintenance activities in occupied buildings. For further information, refer to Appendix L.
 - 2.1 Affected areas in occupied buildings shall be isolated from adjacent non-affected areas through the use of temporary walls, plastic sheeting, or other vapor retarding barriers.
 - 2.2 Affected areas shall be maintained at a negative pressure relative to surrounding non-affected areas.
 - 2.3 Recirculating air ducts shall be temporarily capped and sealed. If particulates are the only indoor air quality concern, appropriate filters may be used in place of capping and sealing the ducts.
- 3. Protection of the building HVAC system from dust and moisture during major construction, renovation, remodeling, and maintenance activities in occupied buildings.
 - 3.1 Supply air systems shall not be operated without filters in place.
 - a. Filters shall have a minimum sixty- percent (60%) efficiency when passing a three- (3) micron particle.
 - 3.2 Building materials subject to degradation from ambient environmental exposure shall be protected and replaced if damaged.
 - a. Air handling equipment and ductwork shall be stored in a clean, dry location prior to installation and openings shall be securely covered to prevent entry of dust, moisture, and general construction debris and dirt.
 - 3.3 In new construction air-moving equipment shall be used to "flush" the building to reduce off gassing of interior furnishings and finishes a minimum of 48 hours prior to building occupancy. For further information, refer to Appendix M.
 - a. Temporary filters shall be utilized in the air handling equipment during this period.
 - b. Filters shall be replaced after the flushing of the building has been completed.
 - c. Filters shall have a minimum sixty- percent (60%) efficiency when passing a three- (3) micron particle.
- 4. Notification of building occupants of major construction, renovation, remodeling, and maintenance activities.
 - 4.1 Notify potentially affected building occupants of planned work via Facilities Management's alert notification procedure. A brief description of the work and the precautions that will be taken to protect the occupants' indoor air quality shall be included.
- 5. Substitution of equipment and/or materials:
 - 5.1 Substitution of equipment and/or materials that may affect the HVAC system or its ability to maintain acceptable indoor air quality shall be reviewed by the University for consistency with

documented design criteria.

5.2 Requests for substitution of equipment and/or materials shall be made in accordance with the requirements of Section 01600, Material and Equipment, of the MDSS (refer to MDSS tab D, Boilerplate).

6. Ongoing management after work has begun:

6.1 Specifications shall be monitored and enforced.

6.2 Periodic updates on progress shall be provided to building occupants.

APPENDIX A

CLASSIFICATION OF AIR

Return air, transfer air, and exhaust air shall be classified as follows:

Class 1: Air drawn from spaces without unusual sources of contaminants such as offices, conference rooms, classrooms, lobbies, retail spaces, coffee stations, storage rooms (except those housing high-emitting products such as paint supplies), equipment rooms such as air handling equipment rooms, elevator machine rooms, individual dwelling units including hotel rooms, and electrical/telephone closets.

Class 2: Air drawn from spaces that may have mild contaminant intensity, such as copy rooms, printer rooms, dining areas and break rooms, kitchenettes or dining areas with ovens or other cooking or food dispensing capability such as steam tables, cafeterias, laundry rooms, locker rooms, residential kitchens (general or hood exhaust), limited access non-residential toilet rooms (such as those in office buildings and other spaces not open to the general public), and residential or single toilet rooms and bathrooms (except those to patient rooms of health care facilities). For the purpose of this section, a copy or printer room is a room whose primary purpose is to house copy machines and printers, respectively. Air drawn from a room housing the occasional or personal copier or printer may be considered Class 1 air. [Air exhausted from limited access non-residential toilet rooms are placed in this category because the expected frequency of use of these facilities, combined with the minimum exhaust are rates prescribed in the Design Section 2.21., generally result in exhaust gases that have mild odor intensity. Exhaust from toilet rooms that are publicly accessible, particularly those that are heavily used at times such as in airports, theaters, and other assembly spaces, can be expected to have much higher contaminant concentrations and thus qualify as Class 3 air.]

Class 3: Air drawn or vented from locations with significant contaminant intensity, such as nonresidential and public toilet rooms (except those listed above under Class 2), toilet rooms and bathrooms to patient rooms of health care facilities, janitor's closets, commercial kitchens (general and non-grease hoods), laboratories (general exhaust), dry-cleaning processing establishment (general exhaust), indoor swimming pools, diazo printing rooms, and plumbing vents.

Class 4: Air drawn or vented from locations with noxious or toxic fumes or gases, such as paint spray booth, garages, tunnels, kitchens (grease hood exhaust), chemical storage rooms, refrigerating machinery rooms, natural gas and propane burning appliance vents, and soiled laundry storage.

Class 5: Effluent or exhaust air having a high concentration of dangerous particles, bio-aerosols, or gases such as that from fuel burning appliance vents other than those burning natural gas and propane, uncleaned fume hood exhaust, evaporative condenser and cooling tower outlets [due to possible microbial contamination such as legion Ella, the causative agent of Legionnake's Disease and Pontiac Fever].

APPENDIX B

SUPPLEMENTAL EXHAUST

The design documents shall indicate the means by which supplemental exhaust can be provided to meet the requirements of Construction Section 2.2. This section does not require special systems to be installed since they may be installed on a temporary basis, for example by temporarily removing windows for exhaust fans. Rather, this section requires only that the means be indicated in design documents so that it is available when the need for supplemental exhaust occurs in the future.

It is not uncommon for spaces to be temporarily exposed to strong sources of contaminants, such as during remodeling or after an accidental spill of a volatile liquid. These occurrences may be handled by temporary exhaust systems. In many cases, temporary exhaust is difficult to provide such as, in interior spaces of large buildings. To improve flexibility in future renovations, exhaust systems such as those serving toilet rooms can be designed to include additional capacity that may be manually (or automatically) invoked as needed during the building life. Smoke removal systems might also be used for this purpose if approved by the local fire district.

APPENDIX C

LOCATION OF OUTDOOR AIR INTAKES

[This section requires minimum separation distances for outdoor air intakes from known sources of contaminants adjacent to and in the vicinity of the building in order to minimize the introduction of contaminants.] Outdoor air intakes shall be located such that the distance measured from the closest point of the intake opening to the object, or point, listed in Table C1 exceeds the minimum separation distance listed in Table C1. See also Appendix D for restrictions relative to exhaust air outlets.

Exception: Shorter separation distances are acceptable if it can be shown that an equivalent rate of introduction of outdoor air contaminants will be attained using an alternative design, and if approved by the authority having jurisdiction.

The distances required in this section are minimums; in general, locating intakes as far as practical from contaminants sources reduces the likelihood of entrainment. Prevailing winds and airflow patterns around the building and building elements may also be important considerations for intake locations.

**Table C1.
Air Intake Minimum Separation Distance**

Object	Minimum Distance, m (ft)
Property line	1 (3)
Garage entry, loading area, or drive-in Queue (Note 1)	7 (25)
Driveway or street	3 (10)
Limited access highway	7 (25)
Mantels or ledges (Note 2)	1 (3)
Landscaped grade (Notes 3,4)	2 (6)
Roof or grade (Note 4)	0.25 (0.75)
Cooling Towers (Note 5)	5 (15)

Note 1: These areas are likely locations where vehicles will be paused and idling, such as while paying parking fees or waiting for traffic in the case of the garage entry, while loading or unloading materials in case of the loading area, or waiting in line for drive-in restaurant or bank service in the case of the drive-in queue.

Larger separation distances may be needed if the intake is located directly above the likely location.

Note 2: Applies to mantles or ledges that are sloped less than 45 degrees from the horizontal and that are more than 0.15 m (6 in.) wide. [Such ledges tend to become bird nesting or "resting" places.]

Note 3: Landscaped grade is soil, lawn, shrubs, or any plant life within 0.5 m (1.5 ft) horizontally of intake. [The purpose of this section is to minimize the introduction of pollen, odors and vapors from biodegrading materials, pesticides, bacteria, etc. from landscaping.]

Note 4: Intake must be at least 0.2 m (8 in.) above the average maximum snow depth at the intake.

Note 5: Applies to closest wetted surface of tower, such as intake or basin. See Appendix D for separation distance from tower discharge.

APPENDIX D

LOCATION OF EXHAUST AIR AND VENT OUTLETS

Exhaust air and vent outlets shall be located no closer to property lines, outdoor air intakes, windows, and doors, both those on the subject property and those on adjacent properties, than the minimum separation distance S listed in Table D1. S is defined as the shortest "stretched string" distance measured from the closest point of the outlet opening to the closest point of the outdoor air intake opening, window or door opening, or property line along a trajectory as if a string were stretched between them. [For example, if a wall separates an intake from an exhaust as shown Th Figure D1 below the distance S is taken from the exhaust outlet in a straight line to the top of the wall over the wall then in a straight line to the intake. In this case, S-S1 + S2 + S3.1

Figure D1.

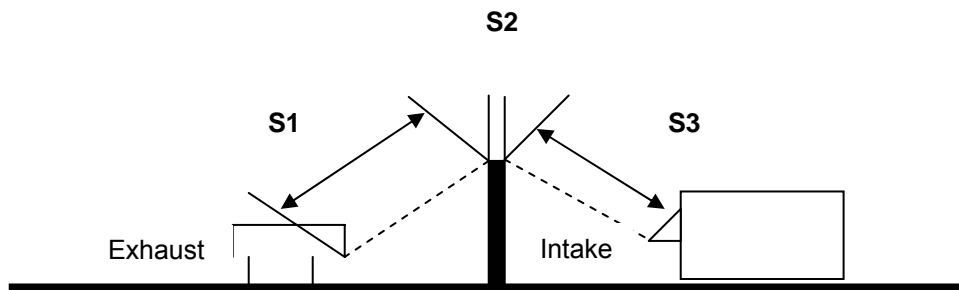

**Table D1
Exhaust Outlet Minimum Separation Distance (S), M (ft)**

Object	Exhaust Air Class (see Appendix A for definition)				
	1	2	3(Note 1)	4(Note 1)	5(Note 1)
Outdoor air intake	Equation D1	Equation D1	Equation D1 (Note 2)	Equation D1 (Note 2,6)	Equation D1 (Note 2,6)
Operable window or door (Note 3)	0.3(1)	Half of Equation D1 (Note 4)	Half of Equation D1 (Note 4)	Half of Equation D1 (Note 4, 6)	Equation D1 (Note 6)
Property line	0	1.5 (5)(Note 5)	3 (10) (Note 5)	3 (10)	5 (15)

Note 1: Laboratory exhaust air outlets shall be in compliance with NFPA 45-1992.

Note 2: Class 3, 4 and 5 air outlets that terminate in an equipment well that also encloses an outdoor air intake shall meet the requirements of Table D1 and, in addition, shall either: a) terminate at or above the highest enclosing wall and discharge air upward at a velocity exceeding 5 m/s (1000 fpm); or b) terminate 1 m (3ft) above the highest enclosing wall (with no minimum velocity). For the purpose of this section, an equipment well is an area (typically on the roof) enclosed on three or four sides by walls that are less than 75% free area, and the lesser of the length and width of the enclosure is less than 3 times the average height of the walls. The free area

of the wall is the ratio of area of the openings through the wall, such as openings between louver blades and undercuts, divided by the gross area (length times height) of the wall.

Note 3: Operable doors and windows that are required as part of a natural ventilation system shall comply with the row labeled "outdoor air intake."

Note 4: Separation distance S is one half of the requirement of Equation D1.

Note 5: For Class 2 and 3 air, where the property line abuts a street or other publicway, no minimum separation is required if exhaust termination is 3m (10 ft) above grade.

Note 6: For Class 5 exhausts located below intakes or operable windows and doors, distance S in Equation D1 shall be a horizontal separation only; no credit may be taken for any vertical separation.

Where Equation D1 is referenced in Table D1, minimum separation distance S shall be determined as:

$$S = 0.04\sqrt{Q}(\sqrt{D} - V/2) \quad (5-1a) \text{ (SI)}$$

$$S = 0.09\sqrt{Q}(\sqrt{D} - VA/400) \quad (5-1b) \text{ (IP)}$$

Where:

Q = Exhaust air volume, L/s (cfm). The value used in Equation D1 shall not be less than 75 L/s (150 cfm) nor exceed 1500 L/s (300 cfm) regardless of actual volume. For gravity vents such as plumbing vents, use an exhaust rate of 75 L/s (150 cfm). For flue vents from fuel burning appliances, assume a value of 0.43 L/s per kW of combustion input (250 cfm per million Btu/hr) or obtain actual rates from the combustion appliance manufacturer.

D = Dilution factor determined as a function of exhaust air class (see Appendix A) in the table below:

Exhaust Air Class	Dilution Factor, D
1	5
2	10
3	15
4	25
5	50

V = Exhaust air discharge velocity, m/s (fpm). V shall have a positive value when the exhaust is directed 75° to 180° away from the object, and shall have a negative value when the exhaust is directed 0 to 74 towards the object) as shown in Figure D2. V shall be set to 0 in Equation 5-1 for vents from gravity (atmospheric) fuel fired appliances, plumbing vents and other non-powered exhausts, or if the exhaust discharge is covered by a cap or other device that dissipates the exhaust air stream. For hot gas exhausts such as combustion products, an effective additional 2.5 m/s (500 fpm) upward velocity shall be added to the actual discharge velocity.

Figure D2.

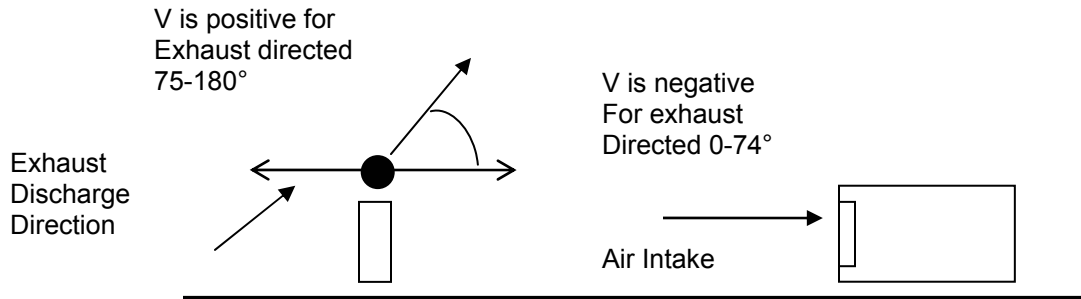

Exceptions:

1. Shorter separation distances are acceptable if it can be shown that equivalent dilution factors will be attained using an alternative design, and if approved by the authority having jurisdiction.
2. Outdoor air intakes need not be separated from furnace vents and other fuel-fired appliance vents that are a part of a unitary or factory packaged heating/ventilating unit that is manufactured within 2 years of the publication date of this standard. This exception applies to the separation of the outdoor air intake and vent discharge of the unit itself and does not exempt maintaining separation distances from one unit to another adjacent unit. [The 2-year time delay is to allow manufacturers an opportunity to redesign and remanufacture equipment in order to meet the separation distances required by this section.]

Separation distances do not apply when exhaust system and outdoor air intake systems do not operate simultaneously.

Note that even where the required minimum separation distances are maintained, reentrainment of odors and toxic gases may still occur depending on wind conditions, building geometry, and exhaust design. An analysis of the air flow pattern around buildings and exhaust plume behavior using the methods described in the AHSRAE handbook, Fundamentals, Chapter 14 can provide more accurate information to assess the potential for reentrainment and to determine adequate separation distances.

[Equation D1 may be summarized as follows:

Class of Air	Dilution Factor D	Square Root of D (\sqrt{D})	Separation Distance At Zero Discharge Velocity		Minimum Discharge Velocity For Zero
			Minimum (75 L/s. 150 cfm)	Maximum (1500 L/s. 3000 cfm)	Separation Distance
1	5	2.24	2.5	11.0	894
2	10	3.16	3.5	15.6	1265
3	15	3.87	4.3	19.1	1549
4	25	5.00	5.5	24.6	2000
5	50	7.07	7.8	34.9	2828

Example 1: a 2000 L/s (4000 cfm) dome type exhaust fan used for toilet exhaust (class 3 air per Section 5.4.1) is located on a roof near a rooftop unit. For class 3 air the intake must be located per Equation D1. Since the exhaust fan discharge velocity is not directed away from the air intake (discharge is down to roof which then deflects out evenly in all directions), the velocity in Equation D1 is taken as zero. Since the exhaust volume exceeds 1500 L/s (3000 cfm), the value of Q in Equation D1 is taken as 1500 L/s (3000 cfm). The equation (in I-P units) is solved as:

$$S = 0.09 \sqrt{3000} (\sqrt{15-0}/400) \\ = 19 \text{ ft}$$

Example 2: Instead of a dome exhaust fan in the previous example, an up-blast exhaust fan is used. The discharge velocity as obtained from manufacturer's data is 6.5 m/s (1300 fpm). The required separation distance is now:

$$S = 0.09 \sqrt{3000} (\sqrt{15-1300}/400) \\ = 3 \text{ ft}$$

Example 3: The flue from a forced draft 880 kW (3 million Btu/hr) input natural gas boiler is located near an operable window. The discharge air quantity is approximately 380 L/s (750 cfm) assuming 0.43 L/s per kW of combustion input (250 cfm per million Btu/hr) (per definition of 0 above). The flue is terminated with a flue cap. So no credit for discharge velocity can be taken. However the flue gas is hot and buoyant and thus a 2.5 m/s (500 fpm) upward velocity may be assumed. The minimum separation distance (in SI units) is:

$$S = 0.04 \sqrt{380} (\sqrt{50-2.5}/2) \\ = 4.6 \text{ m}$$

As a Class 5 air stream, distance S becomes a horizontal separation distance (no credit for vertical separation) when the discharge is below the window (see Note 6 to Table D1).

Example 4: A rooftop AC unit has an outdoor air intake and economizer relief/exhaust outlet (class 1 air per Appendix A) configured as shown in the section below. The relief air (5000 cfm) is directed away from the intake at 2.5 m/s (500 fpm). (If the exhaust outlet distance above the roof is so small that air will be substantially deflected toward the intake, V should be assumed to be zero in Eq. D1) Since the horizontal separation is zero, the minimum separation distance S is simply the vertical distance D in the figure below. Using the maximum value of 3000 cfm in equation D1, this distance must be:

$$S = 0.09 \sqrt{3000} (\sqrt{5-500}/400) \\ = 4.9 \text{ ft}$$

This separation is required not because Class 1 air is unhealthy, but to ensure the air entering the outdoor air is primarily unventilated outdoor air. This example demonstrates that it is impractical to place the intake and discharge as shown without significant recirculation. Possible solutions: Move the intake to the opposite side of the unit; increase the discharge velocity to more than 4.5 m/s (900 fpm); or add a baffle between the intake and discharge to increase the "stretched string" separation distance.

APPENDIX E

RAIN ENTRAINMENT

Outdoor air intakes shall be protected from rain entrainment by use of one of the following:

- a. Louvers or mist-eliminators designed to limit water penetration to 3 mL per m² (0.01 oz per ft²) of free area when tested in accordance with AMCA Standard 500-1994 (15 minute test period).
- b. Rain hoods sized for no more than 5 m/s (1000 fpm) face velocity and tilted at least 45 degrees downward from the vertical.
- c. Louver or mist-eliminators in conjunction with a drain pan complying with Appendix F.

Exposed Internal insulation shall not be located within 0.5 m (1.5 ft) downstream of the air intake louver, eliminator, or screen.

[Water droplets entrained in HVAC system outdoor air inlets provide niches for microbial growth.]

These rain entrainment requirements may not be adequate to control entrainment of snow. Preheat coils with downstream filters or some other scheme may be needed to avoid snow build-up inside outdoor air intakes or on filters.

APPENDIX F

DRAINS AND DRAIN PANS

Drain pans located in supply air ducts, plenums, fan coil units, and other locations shall be sloped and trapped as required to meet the testing requirements in Appendix G. Drains located upstream of fans (those negatively pressurized relative to outdoors or those negatively pressurized to air in a mechanical equipment room) shall have traps having a depth and height differential between inlet and outlet equal to or greater than the fan design static pressure₁ or otherwise sufficient to maintain a water seal and allow complete pan drainage with fans on or off. Traps shall have a means of inspection to verify that the water seal has been maintained [such as an open or screened tee on the downstream end of the trap].¹

Condensate traps exhibit many failure modes that can impact on indoor air quality. Trap failures due to freeze-up, drying out, breakage, blockage, and/or improper installation can compromise the seal against air ingestion through the condensate drain line. Traps with insufficient height between the inlet and outlet on draw-through systems can cause the drain to back-up when the fan is on, possibly causing drain pan overflow or water droplet carryover into the duct system. The resulting moist surfaces can become sources of biological contamination. Seasonal variations, such as very dry or cold weather may adversely affect trap operation and condensate removal.

Exception: Secondary or auxiliary drain pans intended only for emergency overflow collection.

APPENDIX G

TESTING OF DRAINS AND DRAIN PANS

Drainage of pans under cooling coils, air washers, humidifiers, outdoor air intake plenums, and other duct or plenum mounted drain pans shall be tested to ensure proper slope and drainage to prevent conditions of water stagnation that result in microbial growth. Drainage shall be tested using the following procedure:

- a. Temporarily plug the drain and cover the entire pan with 13 mm (1/2 in.) water (or to the maximum allowed by the height of the pan)
- b. Start the fan if it is downstream of pan (in the draw through position). [The fan system must be in operation to test for improperly trapped drains that become air locked when the fan creates a negative pressure in the cold plenum.] Stop the fan if it is upstream of the pan (in the blow through position). [Fan operation assists in coil drainage of blow-through system so the pan must be tested with the fan off]
- c. Remove the temporary plug and observe the performance of the system. Drainage is considered acceptable when the pan drains within 3 minutes to leave puddles no more than 50 mm (2 in.) in diameter and no more than 3 mm (1/8 in.) deep.
- d. For draw-through systems, check to see that the water seal is maintained in the trap with the fan operating. Stop the fan and recheck the seal. The trap is considered acceptable if the water seal is maintained in the trap with the fan both OFF and ON. [Traps are not required by this Standard for blow-through systems since supply air leakage out of untrapped drains is not an IAQ issue. Traps can be provided to eliminate this air leakage for energy conservation purposes.]

Exception: Secondary or auxiliary drain pans intended only for emergency overflow collection need not be tested.

APPENDIX H

MINIMUM AIR CLEANING AND FILTRATION

Mechanical systems that supply air to an occupied space through supply ductwork exceeding 3 m (10 ft) in length or through a humidifier, evaporative cooler, fin-tube heating coil, or cooling coil, shall be provided with particulate filters or air cleaners having a minimum efficiency of 60% when tested in accordance with ASHARE Standard 52.2 for 3 μ m particles. [This standard is pending approval. If it has not been published before this document, the requirement will reference 25-30% efficient filter as rated by ASHRAE Standard 52.1, Atmospheric Dust Spot Method.] Filters racks shall be designed to minimize the bypass of air around the filter media or filter cartridge frames when the fan is operating. [This section is intended to reduce the accumulation in duct systems and on duct components of dirt which may become a source of microbial growth or which may clog the system and affect airflow. It is not intended to address the possible use of cleaning return air to be used in lieu of outdoor air; which is covered in Section 6.4.]

The 60% filtration for 3 μ m particles is a minimum filtration requirement but some particulate accumulation within the ventilation system can still be expected over the life of the system. Where the system design can accommodate higher efficiency levels, efficiency levels of >65% for 1-3 μ m particles will improve indoor air quality with respect to particles and will reduce particulate accumulation in air distribution systems where cleaning is often difficult. Efficiency levels >65% efficiency for particles >0.3 μ m will be most effective where potentially large concentrations of respirable particles may occur.

APENDIX I

INSULATION OF COLD SURFACES

Insulation shall be provided on the following ductwork and piping where located within the building envelope:

- a) Unlined cooling supply ductwork.

Exception:

1. Cooling ducts located within air-conditioned spaces.
2. In other than humid climates, cooling supply ductwork in return air plenums.

[The dewpoint of the return air will generally be less than the surface of the ductwork supplying air to the space. This exception does not apply to humid climates because condensation can occur due to infiltration of humid air into the ceiling plenum and during cool-down transients after moisture has built up in the space when the system was off. Note that insulation of supply ducts in plenums may be required by other codes or may be required to prevent excessive heat gain to supply air]

- b) Chilled water supply and return piping, domestic cold water piping where primary water supply can be expected to be below 13°C (55°F) during the cooling season.

- c) Domestic cold water piping where primary water supply can be expected to be below 13°C (55°F) during the cooling season.

The thickness of insulation shall be as required to prevent condensation on cold surfaces. Insulation that is subject to damage or reduction in thermal resistivity if wetted shall be enclosed with a vapor retarder sealed in accordance with manufacturer's recommendations to maintain the continuity of the barrier. Special coatings that inhibit condensation are an alternative to insulation if approved by the authority having jurisdiction.

[The purpose of this section is to prevent condensation, which may cause material damage or microbial growth in indoor spaces. This section does not consider energy usage, which is covered by ASHRAE 90.1 - 1989.]

APPENDIX J

OUTDOOR AIR INTAKE CONTROL

Variable air volume systems (except those supplying 100% outdoor air) shall include controls and devices to measure outdoor airflow at the air handler and designed to maintain outdoor airflow not less than 90% of required levels over the expected supply air operating range. [A major consideration with VAV systems is that the negative pressure behind the outdoor air intake in the mixed air plenum will typically vary with supply air volume and at low supply volumes sufficient outdoor air flow may not be maintained if a fixed outdoor air intake damper position or even if a dedicated fixed minimum air intake is used. In most cases, an active outdoor air control system must be provided to ensure minimum rates are maintained.]

Acceptable air intake measuring devices include those that measure intake volume directly by measuring air velocity through an outdoor air duct or inlet of fixed area (e.g. duct mounted pilot or hot wire anemometer) or differential pressure across a fixed orifice (e.g. wide open damper or other non-adjustable duct mounted obstruction). If the system includes an outdoor air economizer; a separate minimum outdoor air damper may also be required in order to ensure adequate velocity across the intake for an adequate measurement. Note that a fixed speed outdoor air fan without control devices will not maintain rates within the required accuracy unless the fan curve is relatively steep with respect to changes in pressure and/or if the pressure changes in the mixing plenum are relatively small compared to the fan total pressure requirement. Using return air, outdoor air, and mixed air temperatures or CO₂ concentrations to measure air intake percentage is usually inaccurate when the outdoor and indoor values are close together and thus should not be used for this application unless it can be shown to meet the >90% accuracy requirement. Similarly, measuring outdoor air by taking the difference between supply and return air flow measurements will also seldom meet the >90% accuracy requirement due to cumulative errors in air flow measurement and the generally small outdoor air flow rate relative to supply and return air flow rates.

APPENDIX K

PRE-OCCUPANCY OPERATION

Ventilation systems shall be operated prior to the time any space served is expected to be occupied for a period of time determined in accordance with the requirement specified below and documented in the ventilation system design documentation (see Design Section 2.18).

Ventilation systems shall include either manual or automatic on/off controls that allow the fan system to operate whenever the spaces served are occupied. When thermostats used to control heating or cooling for systems that also supply required ventilation air include a manual switch accessible to untrained personnel that allows the fan to operate only upon calls for heating or cooling, controls shall be included to ensure the hourly average outdoor air supply rate and overall supply air rate are maintained. [Thermostats often have an "auto" position on the thermostat or subbase fan switch that cycles the fan only when heating or cooling is required. When the fan system also supplies ventilation outdoor air, this causes air supply to be discontinuous. Since many untrained people do not understand this, the switch is often placed in the "auto" position, resulting in inadequate ventilation.]

To comply with this section, the thermostat may be provided without an "auto " position, or with the control sequence in the "auto" position modified in a manner that either operates the fan on a continuous basis when the space is expected to be occupied or that activates a time or other device to ensure that hourly average supply air and outdoor air rates are maintained. Systems operated in this manner must be capable of supply more than minimum rates when the system is on in order to compensate for the time the system is allowed to cycle off.

In general, to comply with this section, programmable timeclock thermostats must be capable of operating the fan on the time schedule rather than simply changing setpoints on a time schedule. Note that many residential thermostats do not have this capability.

APPENDIX L

ISOLATION OF MAJOR CONSTRUCTION AREAS

Spaces of an occupied building that are undergoing major construction, renovation, or remedial work that become a temporary but significant source of indoor air contaminants (term "construction areas" hereinafter) shall be isolated from directly adjacent non-construction areas using temporary walls, plastic sheeting, or other vapor retarding barriers. These construction areas shall be maintained at a negative pressure relative to the adjacent non-construction areas by either exhausting construction areas and/or pressurizing adjacent areas. Recirculating return air ducts from construction area shall be temporarily capped and sealed to prevent the spread of contaminants to occupied areas served by the same system. Where particles are the only contaminant of concern, in lieu of capping off return ducts, return air shall be filtered as required to reduce particles with mean diameters less than 10 μm (PM_{10}) to concentrations below those listed in table 5-1. For the purposes of this section, major construction areas within a building undergoing construction activities that require the temporary displacement of occupants for more than 48 hours, or new construction where spaces are newly completed (no former occupants). [This definition is intended to include major tenant work such as complete remodels plus major revisions that include demolishing or finishing drywall partitions, installation of new furnishings and carpeting. Minor touch-up painting and replacement of a small area of carpet are not considered significant contaminant sources.]

These requirements are also applicable to any other construction or installation of materials that generate significant contaminants. Contaminant concentrations within the construction zone itself are covered by applicable construction workplace standards from ACGIH, OSHA, or other local authority. Refer also to IAQ Guidelines for Occupied Buildings under Construction (SMACNA, 1995a).

APPENDIX M

PURGING OF MAJOR CONSTRUCTION AREAS

After construction is complete, major construction areas, as defined in Appendix L, shall be purged by supplying or exhausting no less than the design outdoor air rate required by Section 6 for a period of no less than 48 hours before occupancy. When spaces are exhausted, make-up air may be drawn from adjacent non-construction spaces rather than the outdoors. The requirements of Appendix L, pressurization relationships to adjacent spaces, shall apply until the 48-hour period is complete.

Exception: If it can be demonstrated that an alternative ventilation scheme can provide similar results and if approved by the authority having jurisdiction.

These procedures are also suitable for any other construction or installation of materials that generate significant contaminants. Depending on the new materials in the space and the rate at which they off-gas, a shorter or longer purge period may be required. When ambient conditions and the HVAC system design permit. The effectiveness of the purge, can be enhanced by ventilating spaces at rates far exceeding minimum ventilation rates.

TAB C-12

CAMPUS ACCESSIBILITY

GENERAL OVERVIEW

The University of Arizona (UA) is committed to a universally designed campus. While all institutions of higher education are legally obligated to comply with ADA accessibility standards, UA seeks to maximize access in the built environment to encourage the full and equitable participation of all users. We consider this a great opportunity to build rich diverse communities and contribute to a welcoming campus culture.

Universal Design enhances the viability of the built environment by creating sustainable facilities and outdoor spaces that are usable by all people to the greatest extent possible without the need for modification or adaptation. Designing inclusively will reduce the need for retrofitting or making individual accommodations.

Design Professionals should take into consideration the full range of human diversity with respect not only to disability, but to language, gender, age and other differences or characteristics. Such attention to diversity in the design process is integral to creating socially responsible built environments and will result in design features that facilitate social interaction, community, identity and belonging. Design choices starting from initial site planning to the choice of hardscape and hardware products effect usability and impact equitable design. When spaces are designed “universally,” individuals are no longer disabled by their impairments or differences, and can experience things in the same ways as others.

Seven general principles guide Universal Design:

- 1. Equitable use:** The design is useful and marketable to people with diverse abilities.
- 2. Flexibility in use:** The design accommodates a wide range of preferences and abilities.
- 3. Simple and intuitive:** Use of the design is easy to understand, regardless of the user’s experience, knowledge, language skill, or current concentration level.
- 4. Perceptible information:** The design communicates necessary information effectively to the user, regardless of ambient conditions or the user’s sensory abilities.
- 5. Tolerance for error:** The design minimizes hazards and the adverse consequences of accidental or unintended actions.
- 6. Low physical effort:** The design can be used efficiently and comfortably, and with a minimum of fatigue.
- 7. Size and space for approach and use:** Appropriate size and space is provided for approach, reach, manipulation and use, regardless of user’s body size, posture or mobility.

These design principles should inform the Design Professionals’ creative process from initial decisions regarding orientation of the building on the site and the layout of building amenities throughout the development of the design features, to the choices of products and furnishings.

Project Type Key
N = New Construction
R = Renovation
H = Historic Renovation

Applicability Key
M = Mandatory
P = Preferred

To assist design professionals in applying Universal Design principles to projects at The University of Arizona, the University has developed specific standards – UA Accessibility Standards. **The UA Accessibility Standards are specific measurements, equipment and/or arrangements of accessibility compliance that the University feels provide a more universally accessible condition than the minimum requirements outlined in the ANSI/ADAAG standards.** These standards are also used as reminders for important conditions that are not different than the standards, but often overlooked in design documentation.

UA ACCESSIBILITY STANDARDS DESCRIPTION

The UA Accessibility Standards are organized to coordinate with ADAAG Standards. The types of construction projects have been organized into three groups.

New Construction	N
Renovations	R
Historic Renovations	H

Applicability of these standards is categorized as either **Mandatory (M)** or **Preferred (P)**.

TYPES OF PROJECTS

New Construction

New construction projects are defined as those projects involving the design and construction of new facilities and outdoor spaces where building and site development are unencumbered by pre-existing building or site accessibility constraints. Additions to existing buildings (inclusive of fully attached to minimally connected) are also considered to be New Construction Projects in regards to building accessibility, and, if provided with new entrances from the exterior, also in regards to site accessibility. Individual evaluation of additions to existing buildings should be undertaken early in the design process to outline the extent of existing building and/or site accessibility compliance that will be necessary.

Renovations

Renovation projects are defined as projects involving the renovation/alternation of a portion of an existing building that affects, or could affect, the usability. A renovation that could affect the usability of, or access to, an area of a facility that contains a primary function shall also include improvements to the path of travel to the renovated/remodeled area and the restrooms/drinking fountains serving that area so that they are readily accessible to, and usable by, individuals with disabilities, including individuals who use wheelchairs. These improvements shall be included to the maximum extent feasible, unless the cost and scope of such renovations exceed 20% of the cost of the renovation to the primary function area. Individual evaluation of whether or not such improvements are required should be undertaken early in the design process to outline the extent of existing building and/or site accessibility compliance that will be necessary. Please refer to 2010 ADA Standards Section 202.1-4.

Historic Renovations

Projects involving buildings/sites on the National Register of Historic Places must comply with the UA Accessibility Standards in such a way that impact is minimized and a building/site's historic integrity and character defining features are maintained. The determination of a building/site's historical integrity and character defining features shall be made by an individual meeting the Secretary of the Interior's Professional Qualification Standards for Historic Preservation.

Project Type Key
N = New Construction
R = Renovation
H = Historic Renovation

Applicability Key
M = Mandatory
P = Preferred

Due to the potential range of existing conditions, defining features and significant elements, and the ability of an historic renovation project to address such conditions, it is imperative that each project involving a qualified historic building or site undergo an evaluation early in the design process to outline the scope of accessibility compliance which can be achieved, and explore alternative design options or methods to provide programmatic access required of public entities. Please refer to ADA Standards Section 202.5.

COMPLIANCE REQUIREMENTS

All construction projects, new, renovation and historic renovation, must comply with accessibility requirements, including UA Accessibility Standards.

Accessibility codes, guidelines and standards with which the project shall comply are described in the Design Professional's "Scope of Services" Exhibit to the agreement. (Consult with PD&C if this document is not available to you.) Additionally, there are UA Accessibility Standards that are more specific, restrictive and/or descriptive than the above referenced requirements. These are described in the following pages of this DSS tab. Project compliance expectations are included.

Compliance Requirements Key:

Mandatory M

Compliance with Mandatory UA Accessibility Standards is required.

Preferred P

Compliance with Preferred UA Accessibility Standards is encouraged, but to achieve accessibility as part of a renovation project the University recognizes there may be challenges such as:

- Conditions physically beyond the limits of the renovation or path of travel requirements.
- Spatial/structural/technical conditions which make accessibility infeasible to achieve.
- Conditions which cannot be addressed within a defined project scope or budget.

Project Type Key
N = New Construction
R = Renovation
H = Historic Renovation

Applicability Key
M = Mandatory
P = Preferred

SECTION 1 - BUILDING BLOCKS

N	R	H	Reach Ranges
M	M	M	Except as outlined in this section, the <u>operable portion</u> of building equipment and controls (such as electrical switches, fire alarm pull stations, above work surface telecommunications outlets, thermostats, elevator call buttons, etc.) shall be located 42" max. above the finished floor. For information on reach ranges for equipment in rest rooms, toilet rooms, and bathing rooms, see SECTION 4 - PLUMBING ELEMENTS AND FACILITIES.
M	M	M	Where devices have more than one operable mechanism, and are more than 6" apart, a maximum height of 48" is allowed for the higher mechanism.
M	M	M	Door access card swipes and keypads shall be centered at 38" above finished floor. When a pedestal is used at entrances, use a UA specific ADO/keyless access pedestal.
M	M	M	Control plates for automatic door openers shall be centered at 33" above the adjacent finished surface. For horizontal locations, see SECTION 2 - Accessible Routes, Doors and Doorways.

SECTION 2 – ACCESSIBLE ROUTES

N	R	H	During Construction
M	M	M	Renovations that temporarily eliminate building-wide access features (i.e. change of building entrance, access through building, accessible restrooms, elevators, etc.) shall provide comparable, temporary replacements, including temporary directional signage, for said features. Temporary directional signage placement and wording to be reviewed by UA Physical Access Coordinator.
M	M	M	Construction fencing/staging, earthwork and temporary drainage conditions shall be designed to maintain existing accessible routes or alternative, temporary accessible routes, and directional signage shall be provided.
M	M	P	Temporary ramps used during construction shall have ADA compliant handrails, landings and edge protection, and shall attempt to achieve a maximum slope of 1:16.

N	R	H	Accessible Path of Travel - Exterior
M	M	M	Minimum sidewalk width shall be 6' (72"); wider as required on major routes.
M	M	M	Connect to an accessible campus route at all pedestrian access points to parking structures and other parking facilities.

Project Type Key
N = New Construction
R = Renovation
H = Historic Renovation

Applicability Key
M = Mandatory
P = Preferred

N	R	H	Surface Materials
M	M	M	Decorative ground surface treatments (i.e. exposed aggregate concrete, unit pavers, stone paving, etc.) shall provide a surface free of horizontal gaps or vertical transitions in excess of ½" inch. <ul style="list-style-type: none"> • Provide adequate sealant at expansion joints to minimize level change • Other than joint between building slab and paving, avoid expansion and control joints at maneuvering areas in front of doors • Limit aggregate size in exposed aggregate concrete to ¼" maximum NOTE: Decorative larger aggregate and stonework can be used in areas that are not walking surfaces.
M	M	M	Granular surface materials used to create exterior paths of travel shall include a stabilizer to provide a surface that is usable during all weather conditions. Granular surface materials may not be used on path of travel surfaces with a slope steeper than 1:20.
M	M	M	Changes in surface material, both inside and exterior, shall be provided with a durable transition that will meet the change in elevation height requirement throughout the life of the building/space.
M	M	M	See "Curb Ramps" for information on detectable warning surfaces.

N	R	H	Accessible Routes - Interior
M	M	M	Maintain ADA compliant clear path of travel in areas with movable furniture.

N	R	H	Queueing
M	M	M	Provide clearances and turning radii in compliance with ADA accessible route requirements for all temporary and permanent line stanchions. Stanchion bases cannot reduce the clear width of the queue to less than 32".

N	R	H	Bicycle Parking Adjacent to Accessible Routes
M	M	M	Locate bicycle parking racks so that parked bicycles do not encroach in the accessible path of travel (POT). Allow for bicycles parked with front wheel secured to hoop. Install bicycle rack 24" from POT if parallel, and 48" from POT if perpendicular.

N	R	H	Building Entrances
M	P	P	The main entrance of a building shall be universally accessible via a single route. NOTE: Some buildings might have more than one main entrance.
M	P	P	All building entrances shall be accessible, including "employee" entrances, or entrances other than the "main" entrance.

Project Type Key
 N = New Construction
 R = Renovation
 H = Historic Renovation

Applicability Key
 M = Mandatory
 P = Preferred

N	R	H	Doors and Doorways and Glazing
M	M	M	Kick-plates shall be provided on non-latching doors with push-pull hardware.
M	M	M	<p>Frameless Glass Doors – Detail to provide for the following:</p> <ul style="list-style-type: none"> Decorative contrast at latch-side edge of the door, and on adjacent edge of glass wall or panel An automatic door operator. For banks of frameless glass doors, an automatic door operator will be required at only one door <p>When a floor pivot is used, the required clear width shall be provided when door is in any position. This may require a wider door. Provide a door stop when it is necessary to prevent the door from opening past 90 degrees.</p>
M	M	M	All latching door hardware must be lever handle type.
M	M	M	Doors shall not exceed 5 lb. max. opening force. This is applicable at both interior and exterior doors unless an ADO is provided. Consider this requirement when planning oversize doors.
M	M	M	Door pulls must be usable at standard door handle height (38” – 42”).
M	M	M	<p>The following shall not be used:</p> <ul style="list-style-type: none"> Revolving doors Sliding glass doors with a bottom track (occurring on an accessible route) <p>Pocket doors are not desirable.</p>
M	M	M	Provide information on non-standard door pulls for review and approval prior to inclusion in contract documents. Example: Pulls that extend into lower 34” of door on the push side, which can cause problems for wheelchair users.
M	M	M	At glass wall sections that go to the floor provide a decorative contrast or gradient treatment somewhere within 36” and 48” above finished floor to make it easier for the visually impaired to discern the difference between a plane of glass and an opening. This applies to sliding glass door sections as well.

N	R	H	Automatic Door Operators
M	M	M	<p>Automatic door openers shall be installed at each main entrance to a building. Take special care at courtyard buildings with multiple exterior doors so that all building areas can be accessed by a door with an ADO (this applies at all building levels). See 08720 for ADO product information. See Tab C-6 for bollard mounted installation. In courtyard buildings, ADO’s may be necessary at other essential exterior doors such as classrooms and restrooms.</p>

Project Type Key
 N = New Construction
 R = Renovation
 H = Historic Renovation

Applicability Key
 M = Mandatory
 P = Preferred

M	M	M	Electrical infrastructure for automatic door operators shall be provided at all alternate accessible building entries.
M	M	M	Locate ADO's per Figure 1. For guidance on horizontal placement of control plates for Automatic Door Operators refer to diagrams C12-D1 thru C12-D6. Design Professional shall clearly note ADO control locations on Design Development and Construction Document architectural floor plans for review by PD&C Project Manager and UA Physical Access Coordinator, and for coordination with Amer-X keyless access interface. For vertical placement of control plate for Automatic Door Operators refer to Section 1 – Building Blocks, Reach Ranges.
M	M	M	Use the UA specific pedestal for ADO button and keyless access equipment where an exterior wall location is not available.
M	M	M	Make provisions for incorporating Automatic Door Operator in design of door head frame.

N R H Ramps

M	M	P	Where changes in elevation are encountered (including courtyards and open spaces), provide a universally accessible design that addresses the elevation change, rather than providing separate stairs and ramp.
M	M	M	Where space and grades allow, sloped sidewalks (slope 1:20 or flatter) shall be used in lieu of ramps to overcome changes in elevation.
M	P	P	When used, ramps (defined as anything steeper than a 1:20 slope) shall have a maximum 1:16 slope.

N R H Curb Ramps

M	M	M	Curb ramp slopes shall be 1:12.
M	M	M	Concrete aprons shall be provided at the bottom of curb ramps.
M	M	M	Curb ramps within sidewalks (parallel to the path of travel) shall be provided with a 1:16 slope.
M	M	M	The University's standard for detectable warning surface is TekWay Dome-Tiles manufactured by StrongGo LLC (Phone 520-547-3510, Fax 520-547-3515, Web stronggo.com) or equal . The standard color is Terracotta. The depth of detectable warning surface in the direction of travel shall not exceed 24”.

N R H Elevators and Lifts (see also DSS Section 14000)

M	M	M	Platform lifts shall not be used.
---	---	---	-----------------------------------

Project Type Key
N = New Construction
R = Renovation
H = Historic Renovation

Applicability Key
M = Mandatory
P = Preferred

			SECTION 3 – GENERAL SITE AND BUILDING ELEMENTS
--	--	--	-------------------------------------------------------

N	R	H	Parking Spaces
M	M	M	All accessible parking spaces shall be a universal size of 132” wide with a min. 60” wide access aisle. The 60” aisle can be shared between two spaces.

SECTION 4 - PLUMBING ELEMENTS AND FACILITIES

N	R	H	General
M	M	M	Vestibule (i.e. doors in series) entries into rest rooms are not permitted.
M	M	P	Gender neutral restrooms shall be accessible for the purposes of privacy and/or assisted use. Locate gender neutral restrooms in the same area of the building as gendered restroom blocks (multi-stall restrooms).
M	P	P	Accessible gender neutral rest room(s) shall not be used as a substitute for providing accessibility to multi-stall rest rooms.

N	R	H	Toilet and Bathing Rooms
M	M	P	Single occupant public/employee restrooms shall be fully accessible.
M	M	P	Private toilet rooms for employees, i.e., only accessed through a private office, shall be designed to allow accessible toilet room requirements to be added in the future. Approach, entry, and exit shall be fully accessible. Provide 5’ turning radius within room. Provide blocking for future grab bar installation.

N	R	H	Water Closets and Toilet Compartments
M	M	P	A side approach toilet shall be provided. Where possible, provide an “end stall design” where it is possible to have a 5’ turning radius located completely within the compartment. Where a restroom has more than 1 wheelchair accessible stall, provide 1 for left side approach and 1 for right side approach.
M	M	M	Provide vertical grab bar at water closets in wheelchair accessible, accessible ambulatory stalls and accessible single use bathrooms/restrooms. Comply with ANSI standards for size and placement of vertical grab bar.
M	M	M	When accessible ambulatory stalls are provided, specify an accessible height water closet.
M	M	M	Flush valves for toilets shall be located at the wide approach side of the toilet.

Project Type Key
 N = New Construction
 R = Renovation
 H = Historic Renovation

Applicability Key
 M = Mandatory
 P = Preferred

M	M	M	<p>Toilet Paper Dispensers shall be UA standard continuous feed roll type side by side double, and shall be located so that:</p> <ul style="list-style-type: none"> the center of the dispenser is located no further than 7" from the front of the bowl. there is 1-1/2" clear between the grab bar and the top of dispenser. <p>NOTE: No large roll or 4 roll dispensers are allowed in wheelchair accessible stalls, accessible ambulatory stalls or accessible single occupant toilet rooms.</p>
M	M	M	<p>Seat cover dispensers (when provided) in accessible stalls shall be located away from the grab bar and mounted with slot 42" max above the finished floor.</p>
M	M	M	<p>Door pulls shall be provided on both sides of doors to accessible toilet compartments. For doors that open out from the compartment, a second inside door pull – in addition to the door pull provided at the latch - shall be installed at 36" above finished floor and 8" from the hinge side of the door.</p>
M	M	M	<p>Provide a coat hook at 42" max above the floor in the accessible toilet compartment. Locate on a side wall or partition, or on a pilaster, not on the back of the door. Locate away from the side grab bar so hanging items will not conflict with grab bar clearance.</p>
M	M	M	<p>Latching mechanism for accessible toilet compartment doors shall be operable with a closed fist. Large paddle type preferred.</p>
M	P	P	<p>Provide full length mirror in multi-stall restrooms.</p>

N R H Lavatories and Sinks

M	M	M	<p>Provide 36" width minimum per lav, and position lavs to allow adequate space for soap dispensers and paper towel dispensers on side return walls.</p>
M	M	M	<p>Soap dispensers shall be operable with one hand, and located so that there is clear floor space beneath for access. Locate operable mechanism at 42" max. above the finished floor. Under counter mounted soap dispensers and pump type dispensers are not allowable unless motion operated. Install soap dispensers at sides of lavs to reduce length of reach.</p>
M	M	M	<p>A 29" knee clearance shall be provided under accessible sinks. "Extended" sinks (those with a deep front-to-back dimension) shall not be used to achieve the 29" knee clearance.</p>
M	M	M	<p>Sink faucets shall be automatic, wrist blade, lever-operated, or "push-on" type with delayed shut off to permit single hand operation.</p>

Project Type Key
N = New Construction
R = Renovation
H = Historic Renovation

Applicability Key
M = Mandatory
P = Preferred

M	M	M	Adaptable sinks with accessible cabinetry (such as sinks found in employee kitchen areas, laboratories, dwelling units, etc.) shall be provided with a finished flooring surface in the under-cabinet space. The cabinet door shall be provided with an integral toe kick.
M	M	M	Paper towel dispensers shall be located so that operating mechanism is 42" max. above the finished floor.
M	M	M	Hand dryers with bottom air outlet shall be located so that operating mechanism is at 40" above the finished floor. Hand dryers that hands are inserted into, shall be located so that top of unit is 36" above the finished floor.

N R H Baby Changing Stations

M	M	M	Where provided, baby changing tables shall be located in main public restroom block and mounted so that surface is 34" above the floor. Do not locate within a water closet stall. NOTE: Baby changing tables or other conveniences not associated with using the water closet cannot overlap the minimum dimensions.
---	---	---	--------------------------------------------------------------------------------------------------------------------------------------------------------------------------------------------------------------------------------------------------------------------------------------------------------------------------

N R H Shower Compartments

M	M	M	<p>In non-residential conditions, accessible showers shall:</p> <ul style="list-style-type: none"> • be a 36"x36" transfer-type entry with a padded, fold down bench (with integral support legs) that extends the full width of the stall and is located on the wall opposite the controls/shower head • have grab bars installed in compliance with ANSI requirements <p>For transfer type shower 1/2" high threshold is allowable; beveled, rounded or vertical.</p> <p>In existing buildings where a 1/2" high threshold would disturb structural reinforcement of the floor slab, a 2" high threshold is allowable.</p> <p>Shower curtain can encroach on 36" shower dimension to allow it to be located on the inside of the threshold. Allow 3" maximum from edge of bench to curtain.</p> <p>Locate fire alarm device(s) in bathrooms so that it is visible from all locations within room. Take particular care in locating device so that it can be seen from inside shower stalls (for hearing impaired). If general room device cannot be seen from inside a shower, provide a visual fire alarm device in shower drying area.</p> <p>See Section 8 - Dwelling Units for requirements on shower compartments in residential conditions.</p>
---	---	---	---------------------------------------------------------------------------------------------------------------------------------------------------------------------------------------------------------------------------------------------------------------------------------------------------------------------------------------------------------------------------------------------------------------------------------------------------------------------------------------------------------------------------------------------------------------------------------------------------------------------------------------------------------------------------------------------------------------------------------------------------------------------------------------------------------------------------------------------------------------------------------------------------------------------------------------------------------------------------------------------------------------------------------------------------------------------------------------------------------------------------------------------------------------------------------------------------------------------------------------------------------------------------------

Project Type Key
N = New Construction
R = Renovation
H = Historic Renovation

Applicability Key
M = Mandatory
P = Preferred

SECTION 5 – COMMUNICATION ELEMENTS AND FEATURES

N R H Assisted Listening Systems

M	M	M	Assisted listening systems are required where amplification is provided. Consult with the UA Physical Access Coordinator on the appropriate type of system for the building/space. Preference is to use looping in highly public venues. Ensure appropriate signage is added to the signage package for the space.
---	---	---	--------------------------------------------------------------------------------------------------------------------------------------------------------------------------------------------------------------------------------------------------------------------------------------------------------------------

N R H Emergency “Blue Light” Phones

M	M	M	<p>Access shall be provided to Emergency "Blue Light" Phones. Specifically, the following shall be provided (see also Diagram C12-D7):</p> <ul style="list-style-type: none"> • Accessible approach, with access from multiple directions • Ample accessible clear ground space in front of the operable portion of the phone. Install unit at grade, not on a pad, to maintain operable mechanisms within allowable reach range
---	---	---	----------------------------------------------------------------------------------------------------------------------------------------------------------------------------------------------------------------------------------------------------------------------------------------------------------------------------------------------------------------------------------------------------------------------------------------------------------

N R H Signage

M	M	M	For any signage, interior or exterior, that is not being fabricated by the UA sign shop, UA Physical Access Coordinator shall review and approve.
M	M	M	The ‘active’ wheelchair symbol (wheelchair appearing to be in motion) is to be used wherever a wheelchair symbol is included.
M	M	M	UA Physical Access Coordinator shall review all signage verbiage. For example, UA does not include the word ‘handicap’ on any signage.

SECTION 6 – SPECIAL ROOMS AND SPACES

N R H Auditorium, Tiered Classrooms, and Assembly Areas

M	P	P	In auditoriums, tiered classrooms and assembly areas, wheelchair accessible seating and companion seats shall be provided in a variety of locations throughout the seating area.
M	P	P	Per ADA Guidelines, locate companion seats to provide shoulder to shoulder alignment (front to back) with adjacent wheelchair space, which is measured to be 36” from the front of the wheelchair space.
M	P	P	Wheelchair access shall be incorporated in the primary access route to the stage/teaching station areas.

Project Type Key
 N = New Construction
 R = Renovation
 H = Historic Renovation

Applicability Key
 M = Mandatory
 P = Preferred

M	P	P	In fixed seating situations, aisle seats with fold up arms for use by disabled shall be provided and identified.
M	M	P	When fixed seating is provided with tablet arms, consult with PD&C Project Manager and UA Physical Access Coordinator for accessible equivalent seating alternatives. A table area, or areas with movable seating may be required.

N R H Kitchens and Kitchenettes

M	M	P	Employee kitchens and break rooms must be accessible. Provide work surface 34" above finished floor and a roll under sink. If cabinetry is installed at sink, install doors with integral kick and extend flooring to back of cabinet.
---	---	---	----------------------------------------------------------------------------------------------------------------------------------------------------------------------------------------------------------------------------------------

N R H Academic Laboratories

M	M	M	Academic (teaching) laboratories shall be accessible. Provide accommodations at 5% of work stations (minimum of 1 station) per lab. The accessible work station(s) shall provide, or have the capacity to provide, those elements of laboratory furnishings and equipment specific to the type of teaching expected to be conducted in the laboratory. Use of adjustable modular lab furnishings provide the best adaptability for users of all heights, and for those who use wheelchairs.
M	M	M	Accessible work stations shall include: <ul style="list-style-type: none"> • a bench space, either adjustable in height or a maximum of 32" high at the work station, and 34" high at a sink, with 29" minimum clearance below • access to an ADA compliant sink with single action lever controls or wrist blade handles faucet controls • lab gases and power outlets located on the side of the bench or within 18" of the front edge of the bench with single action lever controls or wrist blade handles • storage facilities (for lab equipment/materials to be utilized by students in the lab) within ADA reach ranges
M	M	M	Where academic laboratories utilize fume hoods, provide 5% of total, or at least one, accessible fume hood with: <ul style="list-style-type: none"> • a 32" high (maximum) work surface with 29" clearance below • gas/services within the hood located on the side of the hood or within 18" of the front edge of the hood, with single action lever controls or wrist blade handles
M	M	M	Eyewashes / safety showers shall be independently accessible and operable by a wheelchair user.
M	M	M	Where non-laboratory teaching amenities (writing surfaces, lecture areas, etc.) are provided within academic laboratories, 5%, or at least one, shall be accessible.
M	M	M	Specific purpose teaching facilities (such as tissue culture rooms) shall provide a wheelchair accessible space with: <ul style="list-style-type: none"> • a 5' diameter turning radius within the room

Project Type Key
N = New Construction
R = Renovation
H = Historic Renovation

Applicability Key
M = Mandatory
P = Preferred

			<ul style="list-style-type: none"> a bench space 2'-6" long with a 32" height (maximum) and a minimum 29" clear space below (for a depth of 9" plus toe space beyond)
--	--	--	--------------------------------------------------------------------------------------------------------------------------------------------------------------------------------------

N R H Research Laboratories

M	P	P	Research laboratories shall have provisions for wheelchair accessibility. The accessible work station(s) shall provide, or have the capacity to provide, those elements of laboratory furnishings and equipment specific to the type of research expected to be conducted in the laboratory. Use of adjustable modular lab furnishings provide the best adaptability for users of all heights and those who use wheelchairs.
M	P	P	Individual research laboratory rooms assigned to specific employees are considered employee work areas. For employee work areas, basic access is required for approach, entry, and exit.
M	M	P	Research laboratory rooms with open assignment workstations/bench space shall be provided with 5% of total, or at least one accessible workstation with: <ul style="list-style-type: none"> a bench space, either adjustable in height or a maximum of 32" high at work station and 34" high at sink, with 29" minimum clearance below an accessible sink with faucet controls located on the side (not rear) with single action lever control or wrist blade handles faucet controls lab gases and power outlets located on the side of the bench or within 18" of the front edge of the bench with single action lever controls or wrist blade handles. aisles 42"-48" wide for accessible bench space/hoods storage facilities within ADA reach ranges
M	M	P	Shared, specific purpose research laboratory rooms (such as tissue culture rooms) in open assignment research laboratories shall have at least one wheelchair accessible workstation/hood with: <ul style="list-style-type: none"> a 5' diameter turning radius within the room A bench space 2'-6" long by 32" high (maximum), and a minimum 29" clear space below
M	M	P	For shared fume hoods in open assignment research laboratories, provide 5%, or least one accessible fume hood(s) with: <ul style="list-style-type: none"> a 32" high (maximum) work surface and a minimum 29" clearance below gas/services within the hood located on the side of the hood or within 18" of the front edge of the hood, with single action lever controls or wrist blade handles

SECTION 7 –FURNISHINGS AND EQUIPMENT

N R H General

M	M	M	When loose furniture may be moved into the path of travel, 42" - 48" aisles for clearance / maneuvering shall be provided.
---	---	---	----------------------------------------------------------------------------------------------------------------------------

Project Type Key
N = New Construction
R = Renovation
H = Historic Renovation

Applicability Key
M = Mandatory
P = Preferred

N	R	H	Seating at Tables, Counters, and Work Surfaces
M	M	M	A minimum of 5% of work/dining surfaces (computer tables, dining tables, study carrels, etc.) used for extended periods of time by transient populations shall be accessible. Surfaces shall be a maximum of 32" above finished floor to the top, and provide a minimum clear height of 28" below the surface. The clear height shall extend a minimum of 9" back from front edge of the surface with a vertical clearance wheelchair footrests beyond. Provide.
M	M	M	Accessible height service / reception counters shall be provided at the primary queuing point or staffing location, not at a secondary location. Counter height shall be a maximum of 34" above finished floor.

SECTION 8 – DWELLING UNITS

N	R	H	General
M	P	P	Residence Halls shall incorporate adaptable design features to allow persons with disabilities a wide range of housing options throughout the Residence Hall system.
M	P	P	Common areas and amenities in Residence Halls shall be accessible to all residents and visitors.
M	M	P	Locate fire alarm device(s) in bathrooms so that it is visible from all locations within the room. Take particular care in locating a device so that it can be seen from inside shower stalls (for hearing impaired). If general room device cannot be seen from inside a shower, provide a visual fire alarm device in shower drying area.
M	M	P	Provide accessible student rooms that have accommodations for both wheelchair users and the hearing impaired. Also provide accommodations for the hearing impaired in a portion of the non-wheelchair accessible student rooms.
M	P	P	Residence Halls shall provide all residents and visitors access to all publically accessible areas of the facility.

N	R	H	Entrances
M	P	P	Some residence halls will have student rooms accessed by proximity card readers. At these halls, all accessible building entries shall also be provided with proximity card readers, as well as automatic door operators.
M	P	P	All other accessible building entries to residence halls shall be provided with automatic door operators.

Project Type Key
N = New Construction
R = Renovation
H = Historic Renovation

Applicability Key
M = Mandatory
P = Preferred

N	R	H	Paths of Travel
M	P	P	Stairs and elevators shall be located on a common route within the building as close together as possible.
M	M	M	Interior doors along the path of travel to wheelchair accessible rooms and those to building wide amenities/services (i.e. kitchen, laundry, study/common rooms, etc.) shall be provided with automatic door operators.
M	M	M	The locations of wheelchair accessible rooms within residence halls shall be: <ul style="list-style-type: none"> • on a convenient path of travel from the main entrance and elevator • close to building-wide amenities/services (i.e. kitchen, laundry, study/common rooms, etc.)

N	R	H	Doors
M	P	P	Wheelchair accessible rooms on all floors of a residence hall shall be provided with the infrastructure for automatic door operators. Some wheelchair accessible rooms shall also be provided a with proximity card reader. Review quantity and location required with PD&C PM and UA Physical Access Coordinator.
M	M	P	In residence halls that have student rooms accessed by proximity card readers, all doors on the path of travel to those rooms shall also be provided with a proximity card reader, as well as with an automatic door operator.
M	M	P	If “peep holes” are provided to resident rooms, provide an additional “peep hole” at 48” above finished floor in the doors of wheelchair accessible rooms.
M	M	M	Infrastructure for door knock signalers (i.e. strobes) shall be provided for the entry doors to hearing impaired accessible rooms. Provide alert signaler in all interior rooms within the suite.

N	R	H	Bathrooms
M	M	M	Shower compartments in residential accessible bathrooms shall be 30” x 60” roll-in and have: <ul style="list-style-type: none"> • a padded, fold down bench with integral support legs installed on the wall adjacent to the controls/shower head • the shower head and controls located on back wall of shower, adjacent to the seat wall A 1/2” high threshold is allowable; bevel to maintain compliance with ADAAG change in level requirements.
M	M	M	Accessible lavatories in residential accessible bathrooms shall be provided with counter space (to accommodate personal care items).

Project Type Key
N = New Construction
R = Renovation
H = Historic Renovation

Applicability Key
M = Mandatory
P = Preferred

N R H Closets

M	M	M	Provide adjustable height closet rods and shelves in accessible apartments and student rooms in residence halls. 50% of storage shall be at accessible height.
---	---	---	----------------------------------------------------------------------------------------------------------------------------------------------------------------

N R H Windows/Window Coverings

M	M	M	All operable window mechanisms to open/close window(s) in wheelchair accessible rooms shall be within accessible reach ranges.
M	M	M	Operators for window coverings in wheelchair accessible rooms shall be within accessible reach ranges.

N R H Flooring

M	M	M	Provide sheet goods flooring (no carpet) in wheelchair accessible student rooms.
---	---	---	----------------------------------------------------------------------------------

Project Type Key
 N = New Construction
 R = Renovation
 H = Historic Renovation

Applicability Key
 M = Mandatory
 P = Preferred

TYPICAL ADO LOCATIONS

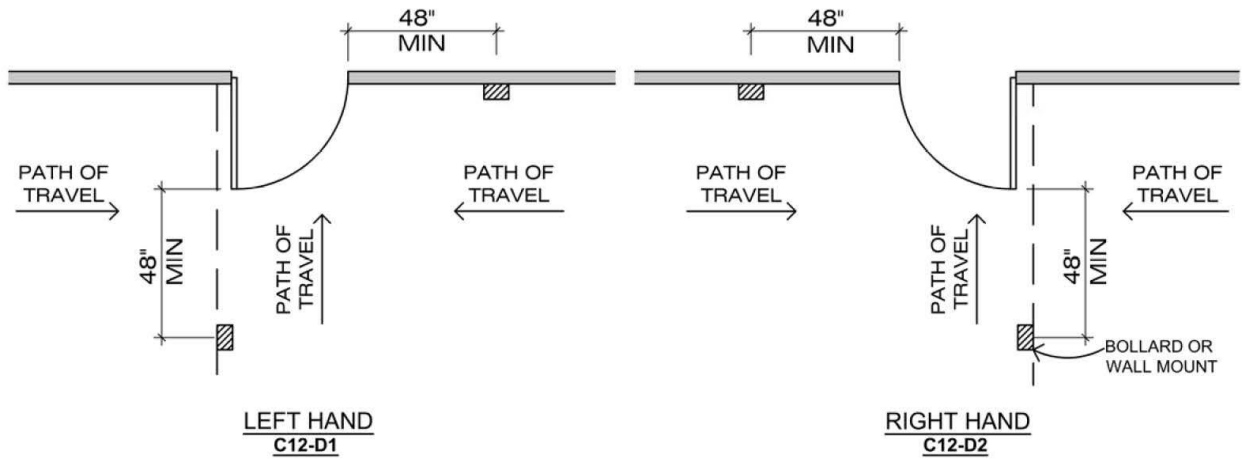

SINGLE DOOR WITH ADO

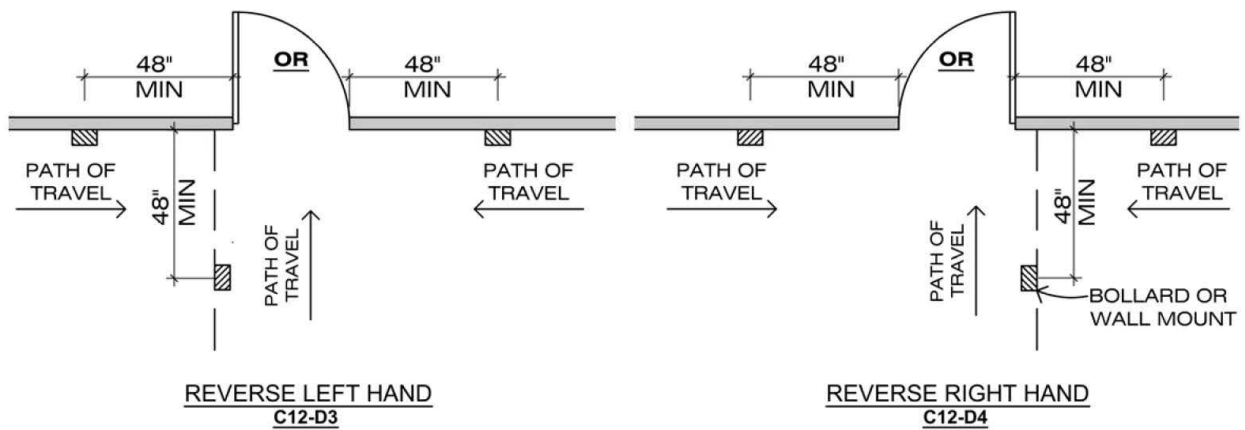

SINGLE DOOR WITH ADO

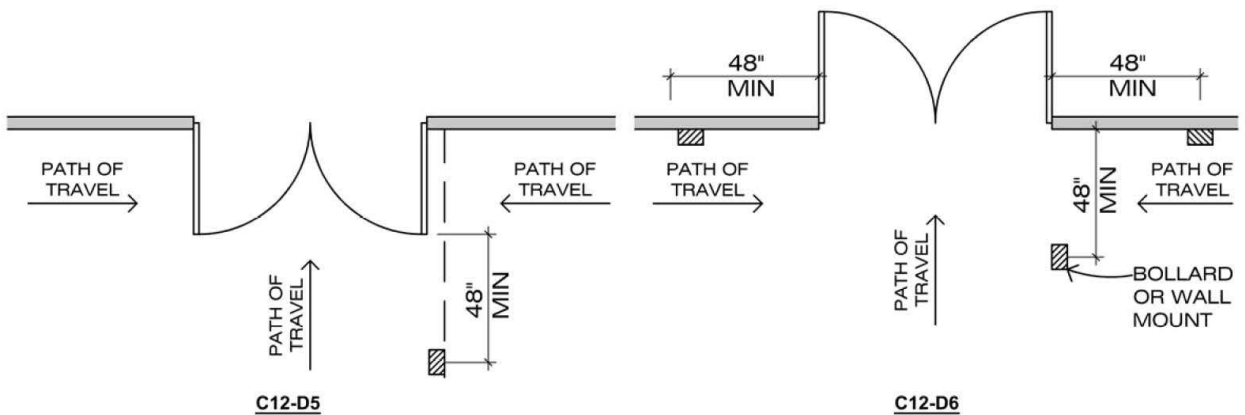

DOUBLE DOOR WITH ADO

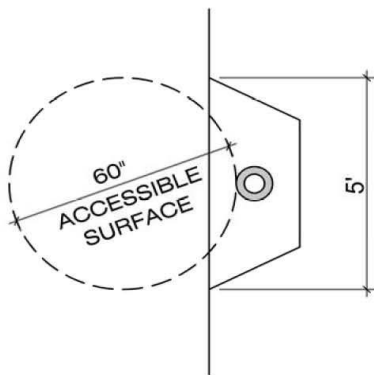

PLAN
C12-D7

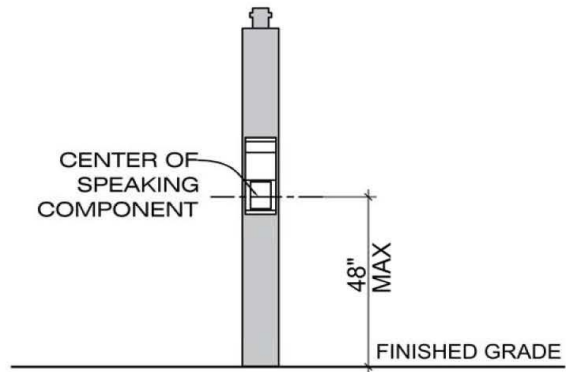

ELEVATION
C12-D8

BLUE LIGHT PHONE PEDESTAL

End of TAB C-12

TAB C-13

CAMPUS SUSTAINABILITY

As stated in the presidential memorandum on Campus Sustainability at the University of Arizona dated 9/28/07, the University is committed to a leadership role in promoting sustainability on our campus and in our design and construction practices. The University has established a goal, wherever appropriate, to acquire LEED Silver Certification as established by the United States Green Building Council. Therefore the following criteria should be followed:

- **WHERE REQUIRED**

- **New Buildings** - A minimum of LEED Silver Certification for all new construction, where appropriate.
- **Building Expansions** - Major building expansions should anticipate LEED Silver Certification for the expansion, if possible, and if the project scope and budget support it, for the entire building. This goal will be established at project initiation.
- **Renovations** - Renovation projects are defined as those projects involving the alteration of a portion of an existing building. Renovations range from simple aesthetic improvements to complex physical reconfigurations and systems' replacement. Due to the potential range of existing conditions – and the ability of a renovation project to address such conditions – it is incumbent that each renovation project undergoes an evaluation early in the budgeting and/or design process to determine if LEED certification can be achieved.

In general, for minor renovations or room specific renovations, requirements for LEED Certification will not be part of the project scope. For projects where major renovation is part of the scope, inclusion of LEED Silver Certification should be anticipated. For example, in major renovation projects that affect entire floors or buildings, LEED Silver Certification should be anticipated if reasonably feasible.

- **DESIGN CRITERIA**

- In general, sustainable design precepts appropriate for the Sonoran Desert environment should be incorporated – water conservation, building orientation, sun exposure and shade are issues of special concern in desert environments.
- Appropriate passive solar design techniques should be incorporated and where the project scope and budget support it, solar water heating and photovoltaic systems should be considered if determined to be economically viable
- Desert appropriate landscape design, water harvesting techniques and use of the University's reclaimed water system where available should be incorporated.
- Appropriate day lighting design should be considered to minimize the requirements for artificial lighting and to promote the interior/exterior connection of the building.
- Appropriate use of construction materials, mechanical, electrical, and plumbing systems should be selected that not only result in a building with an intended useful life of 50 to 100 years but respond to the attributes of the Sonoran Desert environment.

TAB C-14

GENDER NEUTRAL RESTROOM REQUIREMENTS

As stated in the presidential statement on restroom access at the University of Arizona dated 6/26/06, the University is committed to designating and maintaining a minimum of one gender neutral restroom in as many of its buildings as reasonably feasible. Therefore the following criteria should be followed:

- **WHERE REQUIRED**

- **New Buildings** - A minimum of one gender neutral (GN) restroom should be provided in each new building.
- **Building Expansions** - Major building expansions should include a GN restroom unless it is determined that the existing facility has a restroom that can be designated or converted *as part of the project scope*.
- **Renovations** - Renovation projects are defined as those projects involving the alternation of a portion of an existing building. Renovations range from simple aesthetic improvements to complex physical reconfigurations and systems' replacement. Due to the potential range of existing conditions – and the ability of a renovation project to address such conditions – it is incumbent that each renovation project undergoes an evaluation early in the design process to outline the scope of compliance which can be achieved.

In general, for minor renovations or room specific renovations, requirements for GN restrooms will not be part of the project scope. For projects where major bathroom renovations are part of the scope, inclusion of one GN restroom, if not already extant, should be included. For major renovation projects affecting entire floors or buildings GN restrooms should be provided if reasonably feasible.

Where existing facilities are renovated, converted or re-designated, the gender neutral restroom may contain multiple stalls.

- **Residential Facilities** - Because of the variety of facilities that Residence Life deals with, the Consultant shall discuss with the User specific project requirements and criteria.
- **DESIGN CRITERIA**
 - In new construction, each GN restroom shall meet handicap accessibility criteria. Accessible GN restroom(s) shall not be used as a substitute for providing accessibility to multi-stall rest rooms.
 - In new construction, each GN restroom shall include one diaper changing table in addition to standard restroom fixtures/equipment.
 - Refer to other sections of this DSS as applicable for plumbing and bathroom accessory criteria.
 - The plumbing fixtures in GN restrooms shall count towards the total fixture counts required by code.
 - All GN restrooms will be designated as RESTROOM with the universal male symbol, universal female symbol and universal handicap accessible symbol (if applicable).

End of TAB C-14

TAB C-14

GENDER NEUTRAL RESTROOM REQUIREMENTS

As stated in the presidential policy statement on restroom access at the University of Arizona dated 6/26/06, the University is committed to designating and maintaining a minimum of one gender neutral restroom in as many of its buildings as reasonably feasible. Therefore the following criteria should be followed:

- **WHERE REQUIRED**

- **New Buildings** - A minimum of one gender neutral (GN) restroom should be provided in each new building.
- **Building Expansions** - Major building expansions should include a GN restroom unless it is determined that the existing facility has a restroom that can be designated or converted *as part of the project scope*.
- **Renovations** - Renovation projects are defined as those projects involving the alternation of a portion of an existing building. Renovations range from simple aesthetic improvements to complex physical reconfigurations and systems' replacement. Due to the potential range of existing conditions – and the ability of a renovation project to address such conditions – it is incumbent that each renovation project undergoes an evaluation early in the design process to outline the scope of compliance which can be achieved.

In general, for minor renovations or room specific renovations, requirements for GN restrooms will not be part of the project scope. For projects where major bathroom renovations are part of the scope, inclusion of one GN restroom, if not already extant, should be included. For major renovation projects affecting entire floors or buildings GN restrooms should be provided if reasonably feasible.

Where existing facilities are renovated, converted or re-designated, the gender neutral restroom may contain multiple stalls.

- **Residential Facilities** - Because of the variety of facilities that Residence Life deals with, the Consultant shall discuss with the User specific project requirements and criteria.
- **DESIGN CRITERIA**
 - In new construction, each GN restroom shall meet handicap accessibility criteria. Accessible GN restroom(s) shall not be used as a substitute for providing accessibility to multi-stall rest rooms.
 - In new construction, each GN restroom shall include one diaper changing table in addition to standard restroom fixtures/equipment.
 - Refer to other sections of this DSS as applicable for plumbing and bathroom accessory criteria.
 - The plumbing fixtures in GN restrooms shall count towards the total fixture counts required by code.
 - All GN restrooms will be designated as RESTROOM with the universal male symbol, universal female symbol and universal handicap accessible symbol (if applicable).

TAB C-15

LACTATION ROOM REQUIREMENTS

As required by the Affordable Care Act of 2010, the University of Arizona is committed to designating and maintaining a minimum of one lactation room in as many of its buildings as is reasonably feasible. Therefore the following criteria should be followed:

- **WHERE REQUIRED**

- **New Buildings** - A minimum of one lactation room (LR) should be provided in each new building.
- **Building Expansions** - Major building expansions should include a LR unless it is determined that the existing facility has a LR that can be accessed from the building expansion.
- **Renovations** - Renovation projects are defined as those projects involving the alteration of a portion of an existing building. Renovations range from simple aesthetic improvements to complex physical reconfigurations and systems' replacement. Due to the potential range of existing conditions – and the ability of a renovation project to address such conditions – it is incumbent that each renovation project undergoes an evaluation early in the design process to outline the scope of compliance which can be achieved.

In general, for minor renovations or room specific renovations, requirements for a LR will not be part of the project scope. For projects where major renovations are part of the scope, inclusion of one LR, if not already existing, should be included. For major renovation projects affecting entire floors or buildings, a LR should be provided if reasonably feasible.

- **Residential Facilities** - Because of the variety of facilities that Residence Life operates, the Consultant shall discuss with the User specific project requirements and criteria.

- **DESIGN CRITERIA**

- **Summary** - Mothers returning to the University after childbirth are not only driven to provide for their new babies but also to be productive students and employees. Providing a LR at the University help these students and employees achieve both of these goals. Following the design guidelines given here will yield a LR that is easy to use and offers comfort and respect to mothers.

- **Room Requirements** - Several times a day, a nursing mother needs to retreat to a quiet, closed room to collect expressed milk. She needs a calm restful environment with all the required elements for an efficient and safe pumping session.

A typical pumping session includes changing clothes, sitting at a desk in front of a pump for 15 to 30 minutes, placing milk in storage bottles, washing bottles and pump parts and packing them away until the next pumping session, redressing and returning to work. At the end of the session, the pumped milk must be stored in a refrigerator or cooler. In an eight-hour work day two or three pumping sessions are normal.

The LR shall include actual and perceived privacy. Pumps can be noisy so sound dampening shall be provided to achieve auditory comfort in and around the space.

The LR shall provide a lockable door; a work surface and chair; a small utility-type sink; storage for cleaning supplies and paper towels; a thermostat for the HVAC system; electrical outlets, telephone service and network connections to increase worker safety and productivity. Meet accessibility guidelines for all the features of the room.

- **Size** – Provide a minimum footprint of 7 feet by 7 feet as it will allow for a 5-foot radius circle with 24-inch deep counters on two walls. Other configurations may be acceptable as well.
- **Location** – Locate the LR in a safe area accessible to all.
- **Privacy** - Install a user-operated indicator deadbolt for privacy that will display an “occupied” message to discourage interruptions.
- **Signage** – The LR should be signed as “Family Room” and should include the International symbol for Breastfeeding.
- **Sound Privacy** – Extend walls should reach up to the structure above to minimize sound transmission over them into adjacent spaces. Install sound attenuation in walls to minimize sound transmission. Install fabric panels, curtains, carpeting, or other sound-dampening materials to minimize echoes.
- **Chair** - Provide a task chair suitable for a workstation with seat, back, armrest, lumbar, tension, and height adjustments. The chair shall have casters to allow the user freedom of movement when hands are occupied with bottles of milk and pump parts.
- **Table/Counter** - Provide a minimum 20-inch deep by 30-inch wide plastic laminate or solid work surface for the pump and bottles to rest on in front of the task chair. Provide a 30-inch wide clear knee space beneath the counter. Provide above counter outlets at the work area. Provide telecommunication outlets within easy reach of the work area.
- **Sink** - Provide a sink and faucet (goose neck or kitchen type) combination deep enough to wash bottles and pump parts. Locate the sink adjacent to the work area. Indicate location for University provided soap dispenser.
- **Lighting and HVAC** - Task lighting should be provided over the sink and the work area. Provide overhead lighting for the room. Provide a thermostat in the room for user control and thermal comfort so that the room temperature can be maintained year-round at a comfortably warm level such as in a dressing room.
- **Milk Storage** - Provide a midsize or compact refrigerator for milk storage.
- **Accessories** - Provide a trash can, a paper towel dispenser, a coat rack or coat hooks, a full-length mirror, a magazine rack, and a bulletin board. As many mothers may be sharing the room, provide a bulletin board or other scheduling device outside the door to help schedule room use.

End of TAB C-15

TAB C-16

USE OF SAGE GREEN COLOR ON CAMPUS

Intent

In an effort to standardize the color and therefore unify the appearance of certain site and street furnishings, the University’s 2003 Comprehensive Campus Plan recommends a standard site furniture color to enhance “campus coherence, legibility, wayfinding, and sense of place.”

The University of Arizona’s original school colors were silver and sage. In homage to this original color scheme and to promote a more cohesive campus identity, “Sage Green” has been identified as the University of Arizona’s standard color for site and street furnishings.

General Guidelines

- Site and street furnishings that this Design Guideline applies to include but is not limited to benches, other site furnishing such as tables and chairs, trash cans, light poles, bollards, sign poles, modern street car power poles and electrical transformer cabinets.
- The color specification for **UA Sage Green** is **RAL 6021 (pale green)**. RAL is a world-wide standardized color system for powder coated paint application on metal surfaces. RAL colors are standard colors based on a series of color collections for industry which are published by the Deutsches Institut für Gütesicherung und Kennzeichnung, (German Institute for Quality Assurance and Marking).
- The table below identifies the color components for **UA Sage Green RAL 6021** in the XYZ, RGB, CMY and CMYK color systems.

Color	X	Y	Z	R	G	B	C	M	Y	C	M	Y	K
RAL 6021 Pale green	24.48	29.88 (LR V)	22.25	130	156	120	0.4902	0.3882	0.5294	0.1667	0.0000	0.2308	0.3882

- Optional colors (silver, bronze, black) may be considered based on the site context of the project.
- Projects requesting an optional color must provide written justification for optional color use to include consideration of site context (buildings, hardscape and vegetation) and existing site furniture colors of adjacent projects sharing common open space.
- Optional color requests will be reviewed and approved by the Planning Design & Construction Design Project Manager and Planning Staff. All requested deviations from this guideline will be presented and reviewed by the Assistant Vice President of Planning Design & Construction.
- Semi-public open spaces such as building entries, plazas, and enclosed building courtyards have more latitude in site furniture color selection to allow for architectural and/or departmental expression in the development of exterior space.

- Optional green colors that can be considered for site furniture are **RAL 6013 (reed green)** for elements in the Campus Historic District (approved for Old Main and Women’s Plaza of Honor).

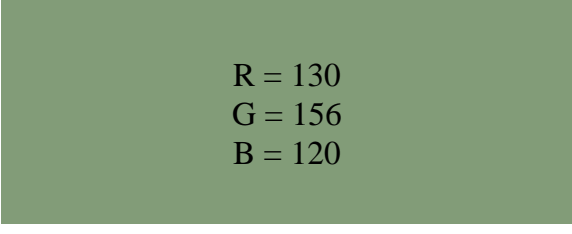
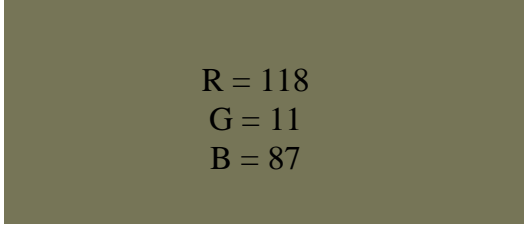
 <p>R = 130 G = 156 B = 120</p>	 <p>R = 118 G = 11 B = 87</p>
<p>UA Sage Green RAL 6021 (pale green)</p>	<p>UA Green Option #1 RAL 6013 (reed green)</p>

- Any liquid paint applications used for site furnishings and light poles must match the applicable RAL color.
- Liquid paint shall be **Hydrogloss**, a polyester water based urethane as manufactured by Sherwin Williams (1802 W. Grant Road, Suite 110, Tucson, Arizona 85745-1232, (520) 323-8080) called “**UA Light Pole Green**” or approved equal.

End of TAB C-16

DIVISION 2 - SITEWORK

Section 02100 - Demolition

Introduction

This section shall be used by the consultant to accurately define the scope of the demolition effort required for the project. Whenever possible a demolition plan shall be created to graphically show the extent of the demolition work.

The scope of the demolition plan should be carefully reviewed and coordinated with Risk Management to ascertain the existence of any hazardous materials requiring special attention. Most laboratory equipment will require decontamination before demolition and/or removal, i.e., fume hoods, laminar flow enclosures, clean benches, biological safety cabinets, etc.

Provisions shall be made in the documents to require that all demolition work be performed without disruption to adjacent occupied areas, i.e., off hours work. Only when the anticipated demolition work will not present a disruption to the user or occupant can the assumption be made that it can be conducted at any time.

Demolition work is usually associated with trash and dust. Appropriate provisions shall therefore be made to address mitigation procedures in the demolition work.

The demolition plan shall identify all materials/equipment, etc., which are to be reused and/or salvaged by either the University or the Contractor. Please keep in mind that all equipment and building material is ultimately the property of the University of Arizona and only when its salvage cost exceeds its usable value is it to be considered unwanted. This determination can only be made by the University of Arizona.

A complete investigation of the area(s) shall be performed so that all existing aspects and elements affected by the project are either removed under the demolition plan or incorporated into the new work with the installation drawings, i.e., existing/abandoned outlets, t-stats etc.

Part 1 - General

- Other than items which are to be reused there are basically two groups of salvageable material presented with nearly all projects. Care must be exercised when handling all salvageable material so as to maintain its value.
- Items which are **always** salvaged by the University.
 - LED exit lights
 - Chalk/White boards
 - EMCS equipment
 - Meters (all kinds)
 - Door hardware
 - Drinking fountains
 - Window blinds
 - Backflow preventers
 - Fire alarm devices
 - Simplex equipment
 - Lab fixtures
- Items which the University may elect to salvage. Depending on the item the University will determine on a case by case basis whether salvage is warranted. The following is a representative, but not conclusive, list of items in which salvage may be considered.
 - Wood/HM doors
 - Electrical panels
 - Mechanical equipment
 - Ceiling diffusers
 - Projection screens
 - Mirrors
 - Irrigation equipment
 - Refrigeration equipment
 - Lab equipment (hoods)
 - Plumbing fixtures
 - Casework
 - Disconnect switches
 - Elevator equipment
 - Soap/Paper dispensers
 - Clocks
 - Access doors
 - Landscape plantings
 - Electrical light fixtures
 - Electrical equipment
 - Starters
 - Windows
 - Transformers
 - Thermostats
 - Shelving
 - HVAC mixing boxes

- Prior to finalizing the construction documents the Architect shall conduct a site meeting with the appropriate Facilities Management personnel and determine precisely what items are to be salvaged. The documents should then clearly identify what is to be salvaged, by whom and where it is to be delivered to or stored. Options include but are not limited to:
 - Removal and transport by contractor.
 - Removal by contractor and transport by UA.
 - Removal and transport by UA.
 - Transportation destinations include the Facilities Management compound, 22nd St. warehouse (Material Management surplus property sales), Sunnyside storage yard or any other location determined during the site meeting.
- Items which are to be surplused and delivered to the 22nd St. warehouse must be accompanied with a completed Request for Property Disposal Form from the Office of Material Management.
- Whenever the UA is to participate in either the removal or transportation of salvage materials a time frame and contact person shall be identified and referenced in the documents.
- All items encountered which contain an affixed University of Arizona Inventory Control tag ("A" tag) require special procedures for dispersal. Consequently these items should be brought to the attention of the UA Project Manager. Items which contain an "A" tag are part of the registered inventory of a particular UA department or unit and dispersal must be coordinated through their respective business manager.
- Fluorescent light fixture tubes and certain light fixture ballasts must be separately disposed of in accordance with applicable environmental regulations. Consequently, the removal and disposal of existing fluorescent light fixtures shall include the following:
 - All fluorescent tubes shall be removed and packaged by the Contractor in cartons supplied by the Facilities Management Electric Shop. The number of tubes in each carton shall be clearly marked on the outside of the carton. Contractor to deliver packaged tubes to the Facilities Management Electric Shop for disposal.
 - Fixture ballasts not clearly marked as containing "No PCB's" shall be removed by the Contractor and after short clipping all wires place them in a metal drum supplied to the jobsite by University of Arizona Risk Management. After completion of the demolition effort University of Arizona Risk Management will remove the drum for disposal offsite. Apportioned disposal costs are then to be charged to the project.

Part 2 - Products

- No discussion.

Part 3 - Execution

- All electrical services discontinued with the demolition effort shall be properly "tagged out".
- Because all facilities within the University of Arizona campus are classified as NESHAP facilities, the regulatory requirements of the Pima County Department of Environmental Quality apply to all demolition projects. Consult with Risk Management to determine the exact requirements. All permits and fees for demolition are the responsibility of the contractor but these requirements should be specifically identified in the contract documents.

End of Section 02100

DIVISION 2 - SITEWORK

Section 02200- Earthwork

Introduction

Inclusion of the Soil Report in the specifications is not permitted on University projects. The Consultant shall make the Report available at his office for Contractor's inspection if they so desire. It is the responsibility of the structural engineer to interpret the report and include specifications for soil preparation in accordance with his structural design. The Consultant should be aware that earthwork may involve not only preparation of soils for building and structures but for parking lots, slabs on grade (sidewalks) and landscaped areas. Appropriate references to other specification sections should be included.

Determine if construction activity resulting from the project will disturb *1 acre* or more. If *1 acre* or more is disturbed a Storm Water Pollution Prevention Plan (SWPPP) will be required and a EPA NPDES Storm Water Construction General Permit must be secured. UA, Risk Management may be contacted for guidance in securing this permit and filing the associated EPA Notice of Intent (NOI).

Part 1 - General

- Surplus material shall become the property of the Contractor and removed from the site.
- Rubble, trash and other demolished materials shall be taken to the appropriate dump sites and disposed of legally.
- Soil testing of compacted fill and/or inspection of caissons will be accomplished and paid for by the University.

Part 2 - Products

- There are no unique University requirements.

Part 3 - Execution

- Comply with City or Tucson and Pima County dust control standards.

End of Section 02200

DIVISION 2 - SITEWORK

Section 02280 - Soil Treatment

Introduction

The work in this section includes treatment of soils under buildings for termites and under paved areas for control of vegetation.

Part 1 - General

- Provide certification as to chemical type, rate of application and a written warranty.
- Warranty for termites and weed growth on new work shall be for 5 years. In alteration/addition work where termite five year warranty is not available, contractor shall certify application rate.

Part 2 - Products

- Chemicals shall be EPA certified and approved.
- Chemical for weed control shall be "Surflan" pre-emergent.

Part 3 - Execution

- Termite treatment is required on new and alteration/addition projects under all footings, along foundation walls and under interior slabs on grade and exterior porch slabs.
- Treatment for weed control shall be applied to soil below paved areas, both asphaltic concrete and concrete flatwork, on open soil area and areas covered with decomposed granite. Application of chemicals shall not be harmful to the roots of adjacent plants.

End of Section 02280

DIVISION 2 - SITEWORK

Section 02500 - Paving and Surfacing

Introduction

A specification section shall be provided for work under this section including Special Provisions and other qualifications as necessary to make the specifications project specific.

Consultants shall tailor their specifications to local practice and University requirements. Testing of materials will be by agencies hired by either the Contractor or the University.

Require repaving and stripping if staging or yard areas for construction are in an existing parking lot or an adjacent street.

The most current version of the Arizona Bicycle Planning and Design Guidelines shall be used for design and specification of paving and signage for bicycle routes and facilities.

Concrete surfaces shall be provided at motorcycle parking and in maintenance areas where oil or gas spillage could occur.

Minimum standard parking space size on the U of A campus is 8'-4" wide x 18'-0" long. Minimum lane width is 20'. The universal 11'-0" wide handicapped space is standard with 5' unload zone, white or blue handicap sign on pavement and HC sign on post complying with ADA requirements.

Handicapped ramps shall be provided when the project is located at an intersection and at other intervals along a street if crosswalks are provided. Inclusion of these ramps should be evaluated with the Project Coordinator.

Part 1 - General

- Damage to existing utilities shall be repaired and made good by the contractor.
- Cold patching may be used only as a temporary measure. Permanent patches must be hot mix.
- The most current versions of the Standard Specifications for Public Improvements and the Standard Details for Public Improvements by Pima County and the City of Tucson shall be used and referenced for this work.
- Consultant shall evaluate project sidewalks considering that heavy University maintenance vehicles will use some pedestrian sidewalks pathways for access to grounds and buildings. Provide design for these identified sidewalks and pathways that will provide the required structural support for University maintenance vehicles. In consultation with the University, identify those sidewalks and pathways that are most likely to provide this access.

Part 2 - Products

- There are no unique University requirements in this Section. Generally design mixes should conform to City of Tucson standard mixes.

Part 3 - Execution

- The most current versions of the Standard Specifications for Public Improvements and the Standard Details for Public Improvements by Pima County and the City of Tucson shall be used or referenced for this work.
- If asphalt patch is less than 25 sq. ft., hand method of placement and screeding can be used. Materials must be hot mix.

- If asphalt patch is greater than 25 sq. ft. or a critical area, use lay down machine.
- When working at curbs, widen excavation, form and pour curb, cut straight asphalt edge, and patch.
- All asphalt cuts shall be saw cut.
- Manholes and valves shall be adjusted to grade after paving. Final adjustment shall be provided with concrete paving patch to roadway grade.

End of Section 02500

DIVISION 2 – SITEWORK

Section 02610 - Site Chilled Water and Heating Water Utilities

Introduction

Piping of site utilities

CHILLED WATER, HEATING WATER

Part 1 - General

- Refer to Section 15050 common piping materials and methods.
- Refer to Section 15250 for insulation requirements.
- Refer to Section 15980 for meter requirements.

Part 2 - Products

- Pipe Schedule:

<u>Service</u>	<u>Size</u>	<u>Pipe</u>	<u>Fittings</u>	<u>Joints</u>
Chilled Water	4" and larger	Ductile iron, lined	Ductile iron, lined	Bell & spigot or mechanical joint
	16" and over	May Use Concrete cylinder	Concrete cylinder	bell & spigot
	Below 4"	Type K copper seamless Hard drawn	wrought copper	15% silver solder
Heating Water Pre-insulated Pipe System	All sizes	Copper - Type "K" Seamless Hard Drawn	Wrought Copper	15% Silver Brazed
		<u>Or</u>	<u>Or</u>	<u>Or</u>
		Schedule 40 Steel	Forged carbon steel	Bevel welded

- Pipe & fittings
 - Ductile iron pipe and fittings to be cement lined and coated with bituminous material per AWWA.
 - Concrete cylinder pipe and fittings to be cement or cement-mortar lined and coated per AWWA.
 - Pre-insulated pipe system, Terra-Gard System by Perma-Pipe or approved equal
 - Copper carrier tube, ASTM B88, Type K, seamless, hard temper

- Steel carrier pipe to be ASTM A53, seamless, carbon steel, Schedule 40
- Polyurethane, closed cell insulation
- PVC jacket per ASTM D1784
- Valves – Buried
 - Chilled Water
 - Resilient seated gate valves for pipe up to 12”.
 - Butterfly valve for pipe over 12” conforming to AWWA C504 and Tucson Water Specification No. 1411
 - Heating Water
 - Butterfly valve conforming to AWWA C504 and Tucson Water Specification No. 1411
- Joint Restraint Devices
 - Ductile iron mechanical joints – Megalug joint restraint
 - Ductile iron flange connection –Megaflange joint restraint flange adapter
 - Integral ductile iron joint – TR Flex restrained joint
 - Concrete cylinder pipe - welded
- Valve Boxes – cast iron box and cover
- Air Relief Valve Vaults – cast in place concrete with 30” diameter cover
- Air Relief Valves – APCO Series 140C, cast iron body, SS float, SS lever, Buna –N seat

Part 3 - Execution

- Chilled water piping
 - Ductile iron pipe to be installed per AWWA C600 and Tucson Water Standard Specification No. 1401.
 - Concrete cylinder pipe to be installed per AWWA M9 and manufacturer’s recommendations.
- Hot water piping
 - Installed per pre-insulated piping system manufacturer’s instructions
- Testing: Hydrostatic, no leakage permitted @100 psig, witnessed by UA Inspector before joints are concealed.

End of Section 02610

DIVISION 2 – SITEWORK

Section 02620 – Site Potable Water and Reclaimed Water Utilities

Introduction

Piping of site utilities

POTABLE WATER, RECLAIMED WATER

Part 1 - General

- Refer to Section 15050 common piping materials and methods.
- Refer to Section 15980 for meter requirements.

Part 2 - Products

- Pipe Schedule:

<u>Service</u>	<u>Size</u>	<u>Pipe</u>	<u>Fittings</u>	<u>Joints</u>
Potable and Reclaimed Water	Up to 3"	PVC-Sch. 40	PVC	Glued
	4" to 12"	PVC- C900 or Ductile iron	PVC Ductile iron	Push-on, mechanical jt
	Over 12"	Ductile iron	Ductile iron	Push-on, mechanical jt

- Pipe
 - Ductile iron pipe and fittings to be cement mortar lined (interior) and coated with bituminous material (exterior) per AWWA. Mortar lining for reclaimed systems shall be double thickness.
 - PVC pipe, AWWA C900.
 - Reclaimed Water- PVC pipe shall be purple (Panatone 522C). Ductile iron pipe shall be encased in purple polyethylene.
- Valves - Buried
 - Potable- For pipe over 12" Butterfly valve conforming to AWWA C504.
 - Reclaimed Water- For pipe over 12" Butterfly valve conforming to AWWA C504.
 - Resilient- Seat gate valves for pipe up to 12".
- Joint Restraint Devices
 - Ductile iron mechanical joints –Megalug joint restraint.
 - Ductile iron flange connection –Megaflange joint restraint flange adapter.
 - Integral ductile iron joint – TR Flex restrained joint.
 - PVC pipe – EBBA Iron Sales Series 1700.

- Valve Boxes – cast iron box and cover.
- Air Relief Valve Vaults – cast in place concrete with 30" diameter cover.
- Air Relief Valves – APCO Series 140C, cast iron body, SS float, SS lever, Buna –N seat.

Part 3 - Execution

- Potable water
 - Installation shall be per Tucson Water Standards.
- Reclaimed water
 - Installation shall be per Tucson Water Standards.
- Testing- Hydrostatic, no leakage permitted@100 psig for 4 hours, witnessed by UA Inspector before joints are concealed.

End of Section 02620

DIVISION 2 – SITEWORK

Section 02640 - Site Natural Gas Utility

Introduction

Piping of site utilities

NATURAL GAS

Part 1 - General

- Southwest Gas Corporation standards are applicable.

Part 2 - Products

- Piping and meters
 - Materials provided by Southwest Gas Corporation per its standards.

Part 3 - Execution

- Installation by Southwest Gas Corporation per its standards.
- Contractor to coordinate activities with Southwest Gas Corporation and provide adequate access to the site.

End of Section 02640

DIVISION 2 – SITEWORK

Section 02710 – Site Sanitary Drainage

Introduction

Piping of site utilities

SANITARY DRAINAGE

Part 1 - General

- Pima County (PC) Standard Specifications and Details are applicable.

Part 2 - Products

- Pipe Schedule

<u>Service</u>	<u>Size</u>	<u>Pipe</u>	<u>Fittings</u>	<u>Joints</u>
Sanitary	Up to 15"	PVC SDR-35	PVC	Bell & Spigot

- PVC pipe per ASTM D3034, SDR 35
 - PVC Fittings per ASTM D3034
 - Joints per ASTM D3212 with gaskets per ASTM F477

Part 3 - Execution

- Installation to conform with PC/COT Standards and Details
- Testing per PC/COT Standards and witnessed by UA Inspector

End of Section 02710

DIVISION 2 – SITEWORK

Section 02720 – Site Storm Drainage

Introduction

Piping of site utilities

STORM DRAINAGE

Part 1 - General

- Pima County/City of Tucson (PC/COT) Standard Specifications and Details are applicable.

Part 2 - Products

- Pipe Schedule:

<u>Service</u>	<u>Size</u>	<u>Pipe</u>	<u>Fittings</u>	<u>Joints</u>
Sanitary	Up to 18"	PVC SDR-35	PVC	Bell & Spigot
	larger than 18"	Reinforced Concrete	Concrete manhole	Gasket & mortar

- PVC pipe per ASTM D3034, SDR 35
 - PVC Fittings per ASTM D3034
 - Joints per ASTM D3212 with gaskets per ASTM F477
- Reinforced concrete pipe to conform with AASHTO M242
 - Concrete manhole materials shall comply with PC/COT Standards and Details
 - Joint materials shall comply with PC/COT Standards and Details

Part 3 - Execution

- Installation to conform with PC/COT Standards and Details
- Testing per PC/COT Standards and witnessed by UA Inspector

End of Section 02720

DIVISION 2 - SITEWORK

02810 – Irrigation

Introduction

As with layout plans and details, specifications shall be coordinated with those of the other design team members. Electric power shall be supplied for controllers and water for the system.

As with layout plans and details, specifications shall be coordinated with those of the other design team members. Electric power and a phone line shall be supplied for the controllers and water for the system.

Part 1 - General

- Damage to existing systems or utilities shall be repaired and made good by the contractor.
- Existing irrigation systems serving plants that remain on site and beyond shall stay fully functional and be protected from damage during construction.
- Any irrigation equipment removed shall be salvaged to the University.
- Materials and installation shall be guaranteed for 2 years.
- Landscaped areas used as Contractor's storage yard and areas impacted by construction shall be restored to pre-existing condition at completion of project.

Part 2 - Products

- The following irrigation equipment is preferred by the University:
 - Controller – “Calsense” controller only with radio remote and Calsense 3000 with Ethernet.
 - Backflow Preventer - Watts, reduced pressure type (for domestic water supply connections).
 - Master Valve – All systems shall have a master valve wired to the controller after the point of connection (POC)
 - Flow Meter – All systems shall have a “Calsense” flow meter installed downstream of the master valve. Flow meter shall be wired to the controller and compatible with central control system.
 - Filter - Agrifim
 - Remote Control Valve (RCV) – Rainbird PSEB-R for potable water systems. Rainbird PSEB-R with non-potable handle for reclaim water systems.
 - Ball Valves - Brass body ball valves
 - Quick Coupling Valves (QCV) – Rainbird 44 DRC for potable water systems. Rainbird 44 DLRC for reclaimed water systems. Also furnish 2 valve keys fitted with ¾" swivel hose ells.
 - Pressure Reducer - Senninger
 - Valve Boxes – Carson with locking lid. Sizes for 1" RCV – 12" Standard; 1 1/2" and 2" RCV – 18" Jumbo. For sizes QCV's - 9" dia. X 10" deep. On reclaim water systems all boxes shall be purple in color. On potable systems boxes shall be green in turf areas and brown/tan in planting areas.
 - Turf Rotors – Hunter I-20 Ultra, I-25 Ultra, I-40 Adjustable, and I-40-ON. Rotors shall have purple tops when used in reclaimed water systems.
 - Rotator Sprays - Hunter Pro-Spray 04-40-CV for potable water, Pro Spray 04-40-CVR for reclaimed water. Hunter MP Rotator Nozzles, 1500, 2000, 3000.
 - Pop Up Sprays –. Rainbird SAM-PRS RD-04 w/check valve, 30 PSI for reclaimed water.
 - Bubbler Heads – Rainbird Bubbler 1404 – 1 GPH and 1408 – 2 GPH
 - Drip Emitters – Rainbird Xeri-Bug emitters. XB-10 and XB-20 only.

- Multi-port Emitters –Rainbird Xeri-Bird XBD-80. Multi-port emitters shall also be enclosed in an “Econo” emitter box, purple in color on reclaimed systems.
- Polyethylene Pipe - Distribution tubing size; .220". Drip system lateral size; .710"
- Polyethylene Fittings –AG Products compression type #710cc. Male barbed-typed fittings are not permitted.
- Polyethylene Dripline – Netafim Techline dripline tubing and Netafim fittings.
- End Caps - AG Products #710cctc
- Polyvinylchloride (PVC) Pipe - Schedule 40 for pressurized lines, Schedule 40 for non-pressurized lines, Class 315 for non-pressurized, 1/2" dia. drip lines. Schedule 40 for all sleeves (I.D. of sleeves shall be a minimum of 1" larger than the O.D. of the pipe or wire bundle it will carry. Purple pipe shall be used on all main lines in reclaimed water systems.
- PVC Fittings – Spears Schedule 80 on all mainlines and Schedule 40 on all lateral lines.
- Threaded PVC Nipples - Schedule 80
- Control and Common Wire - type THWN Neoprene insulated, single conductor; minimum wire sizes shall be as follows: common wire - 12 gauge, control wire - 14 gauge (12 gauge for runs over 1000').
- Splicing Materials: Spears ds-400 prefilled connectors and Spears ds-300 sealer: line splices are allowed only on runs of more than 500'.
- Teflon Tape - for threaded connections.
- Unions – Two schedule 80 unions slip x slip shall be installed on all valve assemblies including master valve.

Part 3 - Execution

- Formal Inspections with University present:
 - Layout (prior to trenching) of all piping, heads and other equipment.
 - Mainline trenches, mainline, water source point-of-connection and control wire valves, quick couplers, controllers, other equipment and electrical power connection.
 - Lateral piping and distribution tubing, spray heads, bubbler heads and drip emitters.
 - Final inspection upon completion of all work.
- Formal testing with University present:
 - Main line: tested for not less than four continuous hours at a static line pressure of not less than 100 PSI, with all isolation valves open, and all pipe uncovered.
 - Flush after installation of laterals and risers and test for watertightness and proper operation of lateral piping, filters, control valves, pressure regulators, end or run flush outlets and other equipment with all pipe uncovered.
 - Flush after installation and test for watertightness and proper operation of drip emitters and distribution tubing, spray heads, bubblers heads.
 - Final operational testing to demonstrate full coverage and proper function of automatic controls.
- Pipe and wiring shall be carried in separate Schedule 40 PVC sleeves under sidewalks and pavement with min. burial depths as follows:
 - Pipe and wires under pavement - 24"
 - Pressurized lines - 18"
 - Non-pressurized lines - 12"
 - Non-pressurized drip laterals - 8"
 - Wire - 12"
- Sleeves shall extend 12" beyond edge of sidewalk and/or pavement.
- Minimum clearances between irrigation lines adjacent to or crossing other irrigation lines or those of other trades shall be as follows:

- 1" diameter and smaller: 6" horizontally, 3" vertically
- Larger than 1" dia.: 12" horizontally, 6" vertically

- Excavations shall allow for 2" (min) of sand bedding or earth fill when rock or unsuitable bearing material is encountered. Provide and compact backfill as follows:
 - Sand bedding or approved earth fill to a point 6" above the top of pipe (for pipe under paving provide 4" minimum sand bedding on all sides).
 - Approved fill free of lumps 1" in dia. and larger to 6" from the top of the trench.
 - Approved topsoil, as specified elsewhere to the top of the trench.

- Snake pipe in trench to allow 1 additional foot per 100" of pipe.

- Holes bored beneath pavement shall maintain an alignment tolerance of no more than 1" in 10', both vertically and horizontally.

- Pipe shall be cut only with an approved pipe cutter. Cuts with a hacksaw or knife are not permitted

- Polyethylene pipe shall be inserted into fittings 1/2" min. Minimum radius of Poly. pipe bends shall be 18".

- Backflow preventers shall be insulated with aluminum tape.

- Install filter immediately downstream of backflow preventer and upstream of control valves.

- Provide thrust blocks for pipe 1-1/2" in dia. and larger.

- All main lines shall have a continuous trace wire laid with the pipe.

- Provide QCV's at 150' (max) spacing along the mainline or around the perimeter of the project, as necessary; install QCV's in valve boxes and on swing joint assemblies perpendicular to adjacent finished grade unless otherwise noted – Schedule 80 1" TxT 90° + 1" Schedule 80 nipple.

- Install RCV's perpendicular to adjacent finished grade unless otherwise noted; provide a minimum of 30" slack in control wires at control valves to allow servicing. Allow 2" clearance between control valves and gravel sump beneath.

- Install end caps in "econo" type valve boxes.

- Install RCV assemblies (RCV, Filter, pressure reducer, QCV, sensor) in valve boxes.

- Tie control and common wires in bundles at 10' intervals.

- Wire splices shall be made in valve boxes.

- Group valve boxes, install no closer than 6" to adjacent walls and not further than 12" from walks, curbs, etc. Install all valve boxes flush with finish grade. Support valve boxes on bricks (min. four) below grade. Provide landscape fabric in the bottom of the box.

- Equipment within valve boxes shall be 4" below lid and quick couplers no more than 3".

- Install spray heads on triple swing joints 6" from adjacent walks, curbs, mowing strips, etc. and with the top of the head flush with adjacent grade.

- Install dripline with fittings from the same manufacturer.

- Install bubbler heads on double swing joints and with the distance from the bottom of the head to adjacent finished grade set at 2".
- Distribution tubing leading from the drip emitter to the surface shall not exceed 5 feet in length, shall extend 2" above adjacent finish grade and shall be secured in the soil with an anchor created by wrapping the tubing twice around a 3" length of 1/2" PVC pipe and buried 8" below grade.
- Affix a non-fading, weather resistant copy of Irrigation Diagram and controller name label to inside of controller cabinet door. The Irrigation Diagram shall show all valves operated by the controller, valve sizes and type of planting irrigated.
- For future expansion add a minimum of 2 extra control wires to the furthest valve manifold in each direction.

End of Section 02810

DIVISION 2 - SITEWORK

Section 02830 - Fences and Gates

Introduction

The items listed below are unique to the University of Arizona requirements and shall be incorporated in to the specifications and drawings prepared by the Consultant.

Part 1 - General

- Refer to the Chain Link Fence Manufacturers Institute Voluntary Standards for Chain Link Fence Installation.

Part 2 - Products

- Fabric shall be 9 gauge, 2" weave w/ Class 2 hot dipped galvanized finish, w/ not less than 1.2 oz. of Zinc per square foot, applied before weaving, and with top and bottom selvages knuckled.
- Framing members (including post, rails, braces, gate frames) shall be Type 1 pipe, Schedule 40, hot dipped galvanized w/ not less than 1.8 oz. of Zinc per square foot of surface: posts and rails shall have caps to exclude moisture; rails shall be attached to posts w/ malleable rail end caps w/ 7/8" beveled steel brace band.
- Posts and rails shall be standard gauge steel pipe sized as follows:
 - Corner posts up to 6 feet tall: 2.375" O.D.; over 6 feet tall: 4.00" O.D.
 - Line posts up to 6 feet tall: 2.00" O.D.; over 6 feet tall: 2.375" O.D.
 - Gate posts for leaves up to 6 feet wide: 2.875" O.D.; for leaves from 6 to 13 feet wide: 4.00" O.D.
 - Gate frames: 2.00" O.D. structural grade pipe
 - Rails: 1.625" O.D. w/ 7" long (min.) mid-span expansion couplings
 - Tension wires: .177" O.D. marcelled steel tension wire w/ Class 2, galvanized coating

Part 3 - Execution

- Foundations shall be concrete with a 28 day compressive strength of 2500 PSI, constructed w/ top of footing 2" above adjacent finished grade and sized as follows:
 - Terminal posts: 16" dia. w/ 39" depth of post embedment
 - Line posts: 12" dia. w/ 39" depth of post embedment
- Terminal posts shall be braced with 1.625" O.D. rail installed between the midpoints of the post and the first line rail (in each direction at corners). Attach braces as rails; secure w/ .375" dia/ truss rods from line post to terminal post.
- Bottom of fabric shall be 2" above adjacent finished grade.
- Attach fabric to posts, rails, braces and tension wires at 15" o.c. (max); attach fabric to posts w/ tension bars and clips; stretch fabric between terminal posts or every 100'. whichever is less.
- Gate hardware for swing gates shall include three hinges per leaf, provisions for pad-locking with cast metal fork latch, drop bolt and drop bolt retainer; hardware for rolling gates shall include heavy duty track, ball bearing hangar sheaves, overhead framing and supports, guides stays, bracing and locking devices as desired.
- Gates shall be braced with midpoint bracing as for terminal posts and with a bottom rail.

End of Section 02830

DIVISION 2 - SITEWORK

Section 02850 - Trash Compactor Embed Plan

Introduction

The placement of a trash compactor on any project is a decision to be made by the University. (Either Facilities Management or Residence Life).

Trash compactors are strategically located throughout campus based on need and it's ability to serve several buildings.

Part 1 - General

- The trash compactor and associated container are provided by the City of Tucson, Sanitation Division.
- A concrete slab with embed plates and electrical power is to be provided per the attached drawing for all trash compactor installations.

Part 2 - Products

- No discussion.

Part 3 - Execution

- No discussion.

End of Section 02850

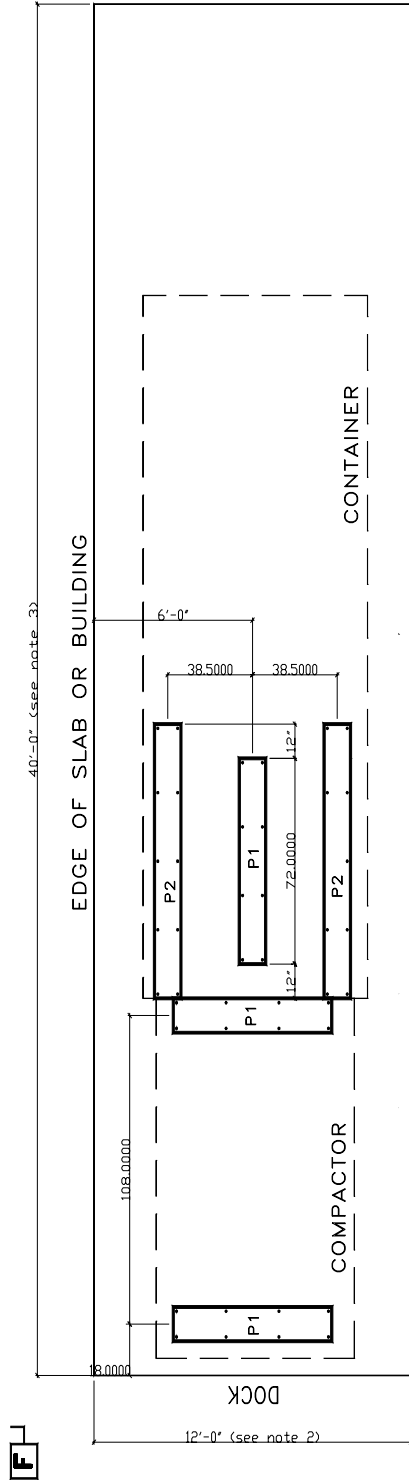

Steel Plate Section Typ.

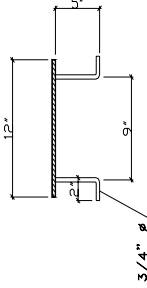

Steel Plate Measurements

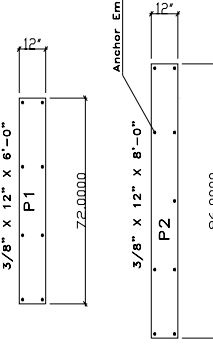

Notes

- 1) Trash compactor and container are provided by the City of Tucson.
- 2) Sanitation Division.
 1) Trash compactor and container are provided by the City of Tucson.
 2) Allowable 10'-0" and a length of 5'-0" greater than the combined length of the compactor and receiver container. If should be of minimum 3,000 lbs. weight. The steel plate should be attached to all anchor bolts. It is preferred to provide 2" clearance at all anchor bolts. If it must be raised above the surrounding ground level, the pad at the end opposite to the compactor should be raised above the surrounding ground level. Provide adequate maneuvering room for the container handling vehicle. Allow a minimum of 45'-0" of clear space from the container-end of the pad for the container handling vehicle.
 3) Overall pad length is dependent on container size. The standard 40 CY container is 108'-0" long. Verify details and container size with the City of Tucson
 Sanitation Division
 City of Tucson
 791-4822
 791-4822
- 4) A lockable fused disconnect switch must be installed and be within sight of the compactor's electrical panel box location, not to exceed 5'-0" from the compactor.
- 5) Disconnect Box must be wired for 3 phase, 230 volts at 60 amps or 480 volts at 30 amps.

UNIVERSITY OF ARIZONA MANUAL OF DESIGN SPECIFICATION STANDARDS	
STANDARD DETAIL:	TRASH COMPACTOR EMBED LAYOUT
DRAWN BY:	R. DOMINGUEZ
APPROVED BY:	02850-D1
ACAD:	D:\DSS\02850-1
REVISIONS:	

DIVISION 2- SITEWORK

Section 02870 - Site and Street Furnishings

Introduction

Benches, tables, bollards, bicycle racks, if appropriate to the facility, shall be included in the project. Generally these items shall be anchored in concrete so as not to be removed. Specify items which can be readily replaced if damaged.

Part 1 - General

- Refer to TAB C16 Use of Sage Green Color on Campus.

Part 2 - Products

- Benches - Concrete, steel strap and perforated sheet steel benches are preferred to wood and fiberglass benches.
- Trash and Recycling Receptacles - Bigbelly solar powered trash and recycling stations. Steel trash and recycling receptacles with a powder coated finish. Frames are fabricated with heavy gauge pipe, angle or flat stock, or solid bar stock. Side panels are fabricated of perforated sheet steel or steel strap. Trash and recycling receptacles have liner and lids. Lids are inconspicuously cabled or chained to the frame. Place trash and recycling containers on a paved surface.
- Bicycle parking racks - ACI (Arizona Correctional Industries) Model MP 4113. Install below grade.
- Kiosks- Bulletin boards must be all weather.
- Tree Grates – Neenah Foundry, Urban Accessories, Canterbury International, Ironsmith. To be installed with frames.
- Drinking Fountains - Haws. Must be handicapped accessible.
- Building ID Signs- By University.
- Removable Bollards- Where removable bollards are required provide bollards as detailed on Dwg. 02870-D1

Part 3 - Execution

- There are no unique University requirements in this Section.

ONE	BOLLARD	1A		
1	4" SCH. 10 PIPE	Z-11	a1	
1	1" SCH. 40 PIPE	1-0	b1	
1	PL 1/2" x 12	1-0	c1	ROUND, SEE DETAIL
1	4" CAP	--	d1	
1	6-0 STRAIGHT CHAIN	--	f1	w/ 7 LINK CHAIN
1	4-0 STRAIGHT CHAIN	--	g1	CUT
ONE	BOLLARD SLEEVE	1B		
1	1 1/2" SCH. 10 PIPE	1'-3 1/2"	h1	
1	PL 1/2" x 12	1-0	k1	ROUND, SEE DETAIL
1	PL 1/2" x 2	0'-5 1/2"	m1	SEE DETAIL
3	3/8" H.S.A.	0'-4"	p1	@ 120°
1	PL 1/8" x 6 1/2"	0'-6 1/2"	l1	ROUND, SEE DETAIL
2	PL 1/8" x 1	0'-1"	v1	
1	6" SCH 40 PIPE	0'-2 1/2"	w1	
1	3/8" PIN	0'-2 1/2"		
1	3/8" SCH 40 PIPE	0'-2 1/2"		

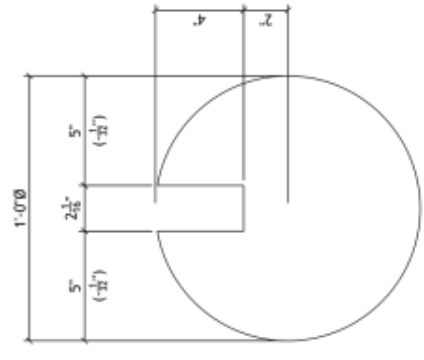
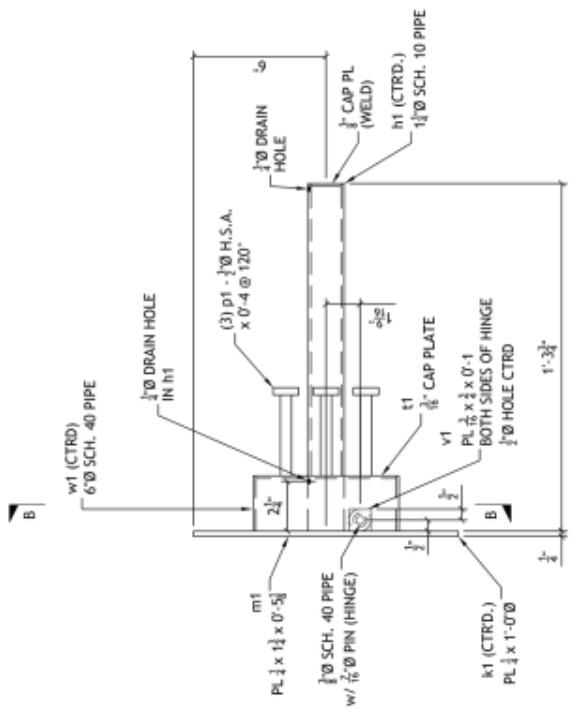

ONE - BOLLARD SLEEVE - 1B

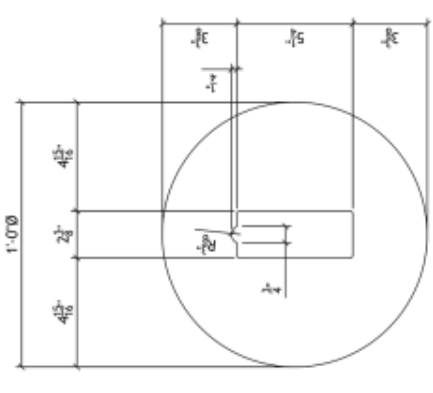

DETAIL OF k1

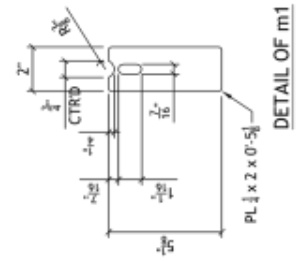

DETAIL OF m1

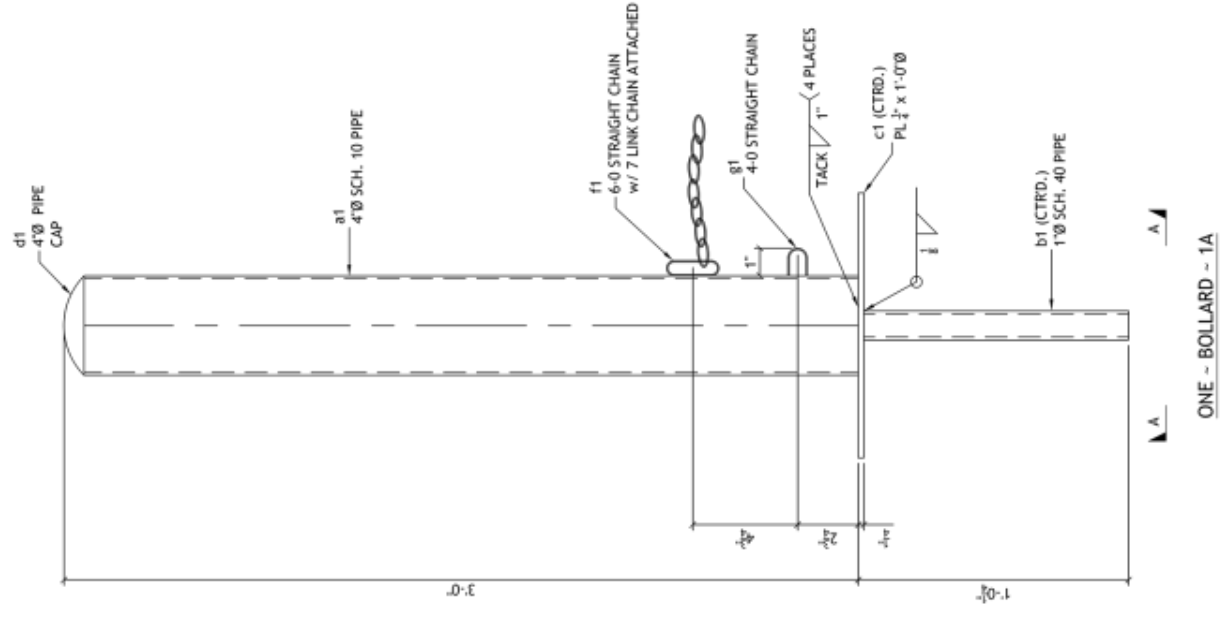

SECTION A-A

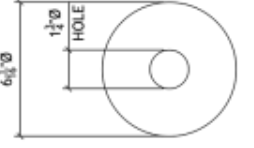

DETAIL OF l1

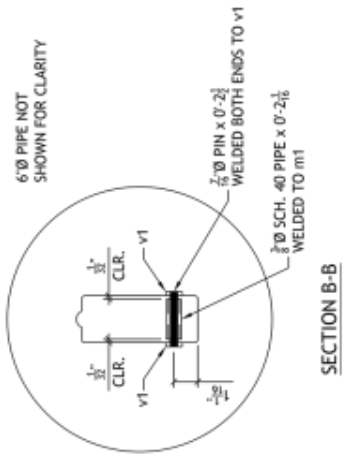

SECTION B-B

UNIVERSITY OF ARIZONA
MANUAL OF DESIGN SPECIFICATION STANDARDS

STANDARD DETAIL: REMOVABLE BOLLARD PROJECT

DRAWN BY: AMD	DETAIL NO.	REVISIONS
APPROVED BY: BD	02870-D1	12-11-15 REV0
ACAD: FILE		--- REV1
		--- REV2
		--- REV3
		--- REV4



Campus Standards for Bollard Appearance

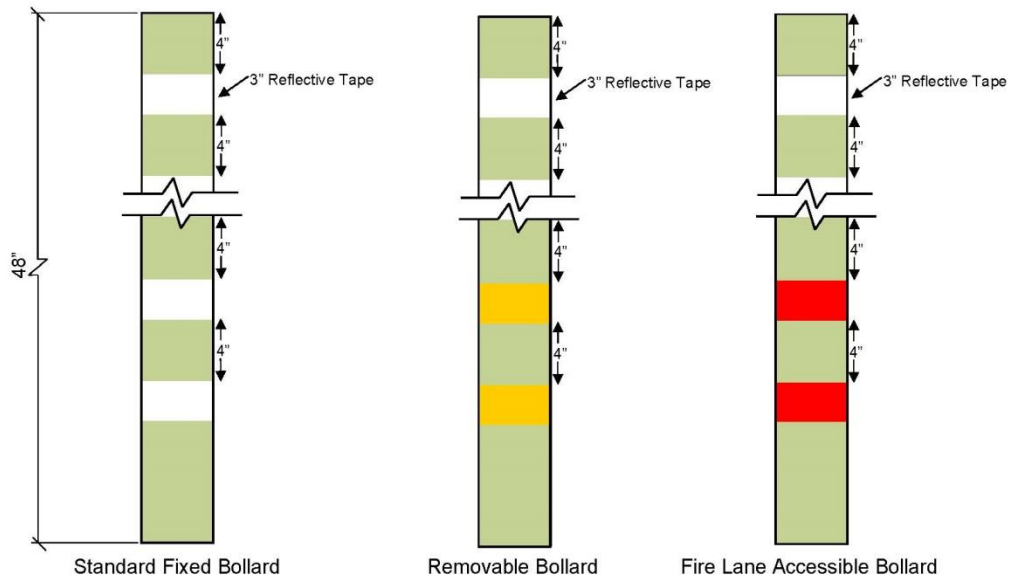

End of Section 02870

DIVISION 2 - SITEWORK

Section 02900 - Landscaping

Introduction

Designers are encouraged to use plant material in energy conserving, climate ameliorating ways. Combinations of deciduous and evergreen shade trees can do much to mediate weather and climatic extremes.

Designers shall refer to site paving drawings and coordinate size of plant pits so as to not undermine hardscape.

The addition of new lawns is restricted due to University agreements with the Arizona Department of Water Resources.

Part 1 - General

- Plant materials shall be selected from the most current revision of the Low Water Use/Drought Tolerant Plant List published by the Arizona Department of Water Resources, Tucson Active Management Area.
- Water harvesting measures should be considered where available.

Part 2 - Products

- Imported topsoil shall be Mesa Red natural, friable loam. Submit written evidence of tests for pH and total dissolved salts (TDS) prior to delivery. pH shall be between 6.5 and 8.0, TDS shall not exceed 1000 parts/million.
- Mulch shall be "Forest Magic" brand or other approved nitrogen stabilized (nitrolized) fine ground fir bark.
- Fertilizer shall be commercial Ammonium Phosphate w/an NPK ration of 16-20-0; use Agriform 20-10-5 formula, 21 gram tablets for salvaged and replanted plants.
- Soil sulphur shall be agricultural grade, pilled or granulated, containing 99.5% active and 0.5% inert ingredients.
- Manure shall be composted, well rotted, free of refuse and containing not more than 25% straw or other bedding material.
- Soil mix for backfilling shall be three parts topsoil to one part mulch with one pound Ammonium Phosphate and two pounds soil sulphur added per cubic yard.
- Tree stakes shall be three (3) inch diameter by eight (8) feet long, pressure-treated Lodgepole Pine, free of any weakening knots or other defect. Stake trees up to 15 gallon size with two (2) stakes. Larger sizes shall be staked or guyed.
- Guy wire shall be new, 12 gauge, annealed, galvanized.
- Chafing guards shall be new, 3/4" dia. reinforced rubber or vinyl hose, 12" long (min) or as necessary to protect tree from guy wires.
- Decorative rock "Desert Gold" or "Wildcat Red" in color, from a local source and shall consist primarily of particles 1/2" to 3/4" in diameter.
- Boulders shall be native Santa Catalina Mountain rock.
- Pre-emergent herbicide shall be "Surflan" or approved equal.

- Palm tying twine shall be natural fiber.

Part 3 - Execution

- New and existing utilities shall not conflict with planting.
- Where plant material will be placed in soil beneath existing pavement, especially asphalt pavement, or other condition where soil sterilant or other treatment potentially harmful to plant material may have been applied shall be tested for the presence of any such chemicals or condition. Affected soils shall be treated and/or excavated and disposed of in accordance with local codes.
- Minimum planting pit sizes shall be as follows:
 - One (1) gallon size container: 18" in dia.
 - Five (5) gallon size container: 36" in dia.
 - Fifteen (15) gallon size container: 60" in dia.
 - Twenty four (24") inch box. 60" square.
 - Thirty six (36") inch box and larger. 18" clear on all sides.
 - Depth of all pits no deeper than the rootball to prevent settling.
- Plant pits shall not undermine hardscape nor shall hardscape elements be placed over plant pits.
- Areas to receive ground cover plants shall be excavated in their entirety to 18" below finish grade and backfilled with backfill mix described above.
- Planting pit percolation rates to be determined prior to planting in the presence of U of A representative.
- After water settling backfill, set plants lower than finish grade to create irrigation basins such that the crown of the root ball shall be 4" lower than surrounding finish grade. Basins shall be as wide as the plant pit. Top of rootball shall be flush with finish grade of the basin.
- 2" of mulch shall be incorporated into the top 3" of soil in irrigation basin areas.
- Root balls of existing palm trees to be transplanted shall have a minimum diameter of 4 feet plus the diameter of the trunk measure 12" above the ground. Vitamin B-1 shall be used per manufacturer's recommendations with the first watering.
- Salvage of existing trees from the project shall be performed by a firm approved by the University and with at least four years experience with this type of work. The work shall be guaranteed and conducted in a manner consistent with local practice. The University shall designate a holding area and source of irrigation for boxed or other wise temporarily stored trees.
- Restoration of turf operations shall include: loosening compacted soil to a minimum depth of 9", removing all rock and debris 1" and larger and adding approved topsoil to match original grade and compaction. 3" of composted, screened, weed free manure plus 2 pounds of Ammonium Phosphate (16-20-0) and 5 pounds of soil sulphur shall be added per 100 square feet and roto-tilled into existing soil to a depth of 6". Between the dates of May 15 and August 15, sow Cynadon dactylon (common Bermuda grass) seed at a rate of 3 pounds per 1000 square feet. Seed shall be 98% pure and have a germination rate of 75%. Between August 15 and May 15, contractor shall provide to the University, but not sow, the appropriate quantity of seed. Roll seeded areas with a 50 pound per linear foot roller then mulch with one-half inch of screened manure.
- The landscape contractor shall maintain all planting until accepted. Maintenance operations shall include: watering, mulching, tightening or adjusting of tree ties, resetting plants to proper grade, restoration of irrigation basins, fertilization and weeding. Replacement materials shall meet all specifications of original materials.

- Where existing lawns have been damaged by construction and are to be repaired by the contractor, follow these instructions:
 - Loosen compacted soil to a depth of 9" min.
 - Remove debris and rock larger than 1" and all contaminated soil.
 - Add topsoil to the level of original grade and allow for settlement.
 - Rototill into the top 6" a 3" layer of manure, 2 pounds Ammonium Phosphate (16-20-0) and 5 pounds of soil sulphur per 100 sf.
 - Broadcast Bermuda grass seed (98% pure, 75% germination) at the rate of three pounds per 1000 sf and cover with a thin layer of manure.
- Sod shall be cut, delivered and installed within a 24 hour period. Cultivate subgrade to a depth of 6" prior to placing topsoil and remove all stones and debris 1" and greater in dia. Place topsoil to a depth of 9" over cultivated subgrade. Topsoil shall consist of equal parts topsoil, sand and manure with 18 pounds soil sulphur, 50 pounds gypsum and 7 pounds Ammonium Phosphate fertilizer (16-20-0) added per 1000 sf.
- Maintenance for new or reestablished turf areas shall be as follows:
 - Maintenance period shall be for 90 days or a minimum of four mowings, whichever is longer, Turf shall be mowed to a height of 1/2" when a height of 1" is reached.
 - Spray heads shall be set 1" above finished grade, initially and reset once turf is established by the contractor at no additional cost. Irrigation shall not result in wilting, puddles or runoff.
 - After 3 weeks and again at the end of the maintenance period, fertilize with a fertilizer that provides one pound available Nitrogen per 1000 sf.
 - Final acceptance will occur with a satisfactory stand of grass (solid, healthy growth, without bare spots) at the end of the maintenance period.
- Palm ties, not broken naturally, shall be cut by contractor after 4 months.
- Berms and swales shall be formed as continuous, smooth landforms with no obvious top or bottom to slopes or grade change from berm to swale.
- Install decomposed granite (DG) 1-3/4" to 2" deep, rake smooth and tamp with a roller of 100 pounds per linear foot weight, minimum. Finish grade shall be 2" below top of adjacent walks, curbs or other pavement. Apply per emergent herbicide, per mfg, instruction, before and after placing the D.G.
- Provide positive drainage away from buildings and structures. Direct runoff water to planting areas.
- All plant materials shall be guaranteed for 1 full year following substantial completion or replacement.

End of Section 02900

DIVISION 2 – SITEWORK

Section 02910 – Temporary Tree and Plant Protection

Introduction

- This section contains standards for protection of in-place and trimming of existing trees that interfere with, or are affected by, execution of the work, whether temporary or permanent construction.

Part 1 - General

- **Tree Protection Zone:** The area surrounding individual trees or groups of trees that are to remain during construction, defined by the drip line of individual trees or the perimeter drip line of groups of trees, unless otherwise indicated.

Part 2 - Products

- Chain-link fence panels for temporary fencing.
- Coarse bark mulch to cover area under protected trees.
- Plant material used to replace damaged plant materials shall be new plant material.

Part 3 - Execution

- **Preparation:**
 - Locate and flag with surveyor's tape trees and vegetation that are to remain or to be removed.
 - Engage Owner's Certified Arborist to direct pruning of trees to remain on site.
 - Install temporary fencing around tree protection zones to protect remaining trees and vegetation from construction damage. Locate fencing as shown on plans. Maintain temporary fence and remove when construction is complete.
 - Mulch tree protection areas with organic matter to a depth of 3 inches.
 - Protect tree root systems from damage caused by runoff or spillage of noxious materials while mixing, placing, or storing construction materials. Protect root systems from ponding, eroding, or excessive wetting caused by dewatering operations.
 - Do not store construction materials, debris, or excavated material inside tree protection zones. Do not permit vehicles or foot traffic within tree protection zones; prevent soil compaction over root systems. Locate portable restrooms outside tree protection zones.
 - Maintain tree protection zones free of weeds and trash.
 - Arrange with Owner for regular irrigation of protected trees.
- **Excavation:**
 - Install shoring or other protective support systems outside the tree protection zone to minimize sloping or benching of excavations onto the tree root zone.
 - **Outside the Tree Protection Zone:**
 - Shovel is to be pulled away from the edge of tree protection zone. If roots larger than 1 inch in diameter are encountered outside the tree protection zone, the Owner's Certified Arborist shall be consulted prior to pruning these roots.
 - Roots encountered during excavation will be redirected into the backfill areas where possible. If large, main lateral roots are encountered, the excavation limits will be extended as necessary to expose roots to a length as required to bend and redirect them into the backfill without breaking. If encountered immediately adjacent to location of new construction and redirection is not practical, cut roots cleanly 3 inches back from new construction.
 - If tree roots larger than 1 inch in diameter require pruning due to construction activities, the Owner's Certified Arborist shall be consulted prior to pruning.
 - Roots exposed during excavation will be protected to prevent drying until permanent backfill is placed.

Exposed roots will be covered with temporary earth cover or packed with peat moss, and wrapped with burlap and regularly watered to, maintain in a moist condition.

- Exposed roots will be temporarily supported and protected from compaction and damage until they are permanently relocated and covered with soil.
- Within the Tree Protection Zone:
 - Where excavation for new construction is required within tree protection zones, do not proceed without the Owner's written approval. Hand clear and excavate to minimize damage to root systems. Use narrow-tine spading forks and comb soil to expose roots.
 - If tree roots larger than 1 inch in diameter require pruning due to construction activities, the Owner's Certified Arborist shall be consulted prior to pruning.
- Utility Trenches: Where utility trenches are required within tree protection zones, do not proceed without the Owner's written approval. Tunnel under or around roots by drilling, auger boring, pipe jacking, or digging by hand. Use existing utility locations where possible.
 - Root Pruning: Do not cut main lateral roots or taproots; cut only smaller roots that interfere with installation of utilities. Cut roots with sharp pruning instruments; do not break or chop. Do not apply any material to cut faces of roots.
 - If tree roots larger than 1 inch in diameter require pruning due to construction activities, the Owner's Certified Arborist shall be consulted prior to pruning.
- Regrading
 - Minor Fill: Where existing grade is 6 inches or less below elevation of finish grade, fill with topsoil. Place topsoil in a single un-compacted layer and hand grade to required finish elevations. Do not grade so that tree trunk is in low spot after finish grading.
 - Change of grade beyond 6 inches: Where existing grade at tree protection zone differs by more than 6 inches from finish grade, construct retaining walls to keep original grade under tree.
- Hardscape around trees
 - In parking lots, allocate 8 foot x 8 foot uncovered space for trees preserved on site. Asphalt cover: Irrigate tree protection zone well the night before. Slope asphalt slightly into planting pit. Flood irrigate again after asphalt installation.
 - Concrete and impermeable paving: Flood irrigate tree protection zone the night before pouring. Protect tree zone from traffic, trash, or backwash during concrete pour. Irrigate tree again the following day.
 - Structural Soil, Structural Cells, and alternative media: Flood irrigate tree zone well the night before. Protect tree zone from backwash or trash during installation of aggregate. Irrigate again the next day.
- Tree repair and replacement
 - Notify the Owner immediately if trees and shrubs to remain in place are damaged during construction. Do not repair damage except with the Owner's Arborist written direction.
 - Promptly repair trees damaged by construction operations within 24 hours of damage. Treat damaged trunks, limbs, and roots according to Owner's Arborist's written instructions.
 - Trees indicated to remain on the site which die or are damaged during construction that Owner's Staff Arborist has determined are incapable of restoring to normal growth pattern will be removed and replaced during construction operations.
 - Provide new trees of same size and species as those being replaced; plant and maintain these trees.
 - Any and all costs of repair or replacement will be assessed to the contractor.

End of Section 02910

DIVISION 2 – SITEWORK

Section 02920 –Tree Salvage

Introduction

This section contains standards for the identification, removal, storage and replanting of existing trees on site.

Part 1 - General

- Create a Reference Sheet for identification of trees to be salvaged.
- Provide backflow prevention devices for the temporary irrigation system
 - Holding Yard: The holding yard for this project will be on or adjacent to the project site with an available water source. Water shall be provided by the Contractor.
- Identification of salvage material
 - The Contractor, Architect and Owner's representatives will determine the final selection of salvage specimens based on specimens already identified, current health, accessibility, viability and appearance.
 - These trees shall be final-tagged with colored tape in conspicuous locations and fenced with temporary construction fence and irrigated to avoid construction damage until they are removed.
 - Contractor is not to remove or work on any salvage material until after the Owner, or designated agent, has determined the limits of the salvage and work area, and has given the Contractor written consent to proceed.
- Removal of salvage material
 - Description of Work: The Contractor shall provide all labor, tools and materials necessary to remove salvage plants from the ground, box them (when required) and transport them to the holding yard.
 - If it is determined that any of the trees to be transplanted can be immediately installed in their new location within the project, the Contractor may do so, but must water, maintain and protect the trees during construction.
 - If any trees are to be transplanted directly onto UA property, the final site will need to be Blue Staked. Allow time for approval.
 - Access: Access shall be entirely within the Owner's property. Damage to surrounding areas not within the property, including but not limited to buildings, curbs, paving, vegetation and utilities, shall be the Contractor's responsibility.
 - The Architect will also identify areas within the property that are not to be disturbed. Any damage within these areas will also be the Contractor's responsibility. If designation of these areas makes access impossible, Contractor shall notify the Architect.
- Protection
 - Contractor shall provide barrier protection to warn pedestrians about the plant excavations, and reasonably prevent someone from falling into one. Protection shall be selected by the Contractor and suitable for the purpose intended and approved by the Architect and Owner.
 - Protection shall be provided during sidebox operations and following removal of the boxed tree, and shall remain in place until the excavation is filled under grading operations.
- Warranty
 - The Contractor shall warranty plants from damage caused by his own operations including boxing, holding and replanting. This warranty includes breakage of major limbs (after trimming), destruction of major root systems, excessive scarring to the trunk, and death from stress or severe insect damage.
 - The Value of the trees to be salvaged shall be determined by a qualified Arborist, and shall be based in whole or in part on the following factors: 1) suitability of the species for the site 2) tree health and vigor prior to start of construction 3) replacement cost for a comparable tree at a local supplier 4) increase in

value of the UA tree based on increase in size beyond that of saleable size 5) rarity within the UA campus tree collection 6) dollar contribution of tree as modeled in USFS i-Tree Suite of software programs

- Should replacement material be required under this warranty, Contractor is responsible for the procurement and transportation of the replacement material.
- Plant materials shall be guaranteed for one year following final acceptance of planting operations under this section.

Part 2 - Products

- **Box Materials**
 - Boxes shall be of wood strong enough to allow transport of trees both to and from the storage facility.
 - Boxes shall be of wood, resistant to rot and fungus, and capable of lasting at least three years.
 - Should the box require replacement, or damage occur to the tree as a result of poor box material, the tree shall be replaced as a warranty item at no additional cost to the Owner.
- **Nutrients**
 - Contractor shall apply chemical nutrients to the tree, as needed, to maintain tree in good health. Balanced fertilizer at ½ strength and Vitamin B-1 shall be used per manufacturer's recommendations with the first watering.
 - Loss of tree from lack of nutrients or over-fertilizing shall be considered a warranty item and the tree shall be replaced at no additional cost to the Owner.
 - Contractor should use an anti-transpiration agent such as Vapor Guard, or approved equal, as needed to prevent excessive wilting and wind damage.

Part 3 - Execution

- **Trimming and Pruning**
 - The Contractor shall prune off all dead limbs from the salvage material.
 - Contractor consult with the Owner's Certified Arborist before removing canopy branching from the tree only, as needed, to reduce stress on tree during the moving operation.
 - Pruning cuts shall be clean and outside the branch collar. Techniques shall follow current ANSI 300 Standards for Pruning. Pruning shall be done in such a manner as to retain the original character and structure of the trees.
 - Any tree which is found to be diseased at this stage may be removed from the salvage list with the approval of the Architect.
 - Contractor is responsible for protection of cuts after pruning. No pruning paint shall be applied to wounds.
 - Architect and Owner's Arborist shall inspect tree pruning prior to sideboxing. Trees which, in their opinions, are of unacceptable shape, size or canopy may be removed from the salvage list at this time.
- **Boxing**
 - Contractor shall identify the size (caliper) of the tree and the corresponding box size. The chart below gives the approximate relationship between box size and caliper size. Contractor may, at his discretion, increase the box size, but should not decrease the box sizes from those listed below. Caliper sizes indicated on the tree inventory plan may vary some from actual conditions. Contractor is responsible for determining actual caliper size for each tree identified for salvage.

Trunk Diameter in inches	Box Size in Inches
Under 4"	42
7-1/2"	45
8-1/2"	48
10"	51
13"	54
14"	57
Over 14"	60 - 120"
 - The Contractor shall sidebox the trees a minimum of 35 days prior to removing the trees.
 - During the sideboxed holding period, the Contractor shall provide water, nutrients and herbicides to the

salvaged material, as needed. Failure to provide proper care during this stage, which results in the loss of the material, shall be treated as a warranty item.

- Removal: As the tree is removed from the ground, the Contractor shall provide reasonable care during this operation to avoid breaking of limbs and scarring of the trunk.
- Transportation:
 - The Contractor shall transport the trees from their location in the field to the designated holding yard.
 - This transportation includes the loading and unloading of the trees from the truck or other transporting vehicle.
- Maintenance of plants during holding period
 - The Contractor shall provide all labor, tools and materials necessary for the maintenance of the salvage materials in the holding yard during a holding period as previously specified.
 - The Contractor shall be responsible for the replacement of salvage material which dies or is seriously damaged during the holding period. See the warranty section for complete specifics of this warranty.
 - Holding Yard:
 - The Contractor shall store or make arrangements for the storage of all salvaged material in the secure yard during construction. This yard shall be located as designated by the Architect and Owner's Representative.
 - The holding yard shall be open for prearranged inspections on a regular basis by the Architect and Owner's Representative.
 - All salvage material shall be clearly labeled and stored in one specific location if other plant material is stored onsite.
 - Time Limitation: The Contractor shall be responsible for maintenance of the material as previously after delivery of the material to the holding yard.
 - Water: The Contractor shall be responsible for provision of a temporary drip irrigation system sufficient to provide water to the salvage material. Contractor shall be responsible for making new connection and removing temporary lines at end of holding period.
 - Fertilizer: The Contractor shall be responsible for provision of nutrients needed to maintain the material in a healthy condition.
 - Other: The Contractor shall be responsible for the provision of any other materials necessary for the maintenance of the salvage material in a healthy condition and secure location.
 - The Contractor shall provide qualified manpower on a regular basis to inspect the trees for health and vigor.
 - The Contractor shall participate with the Architect and Owner's Representative on a monthly basis for inspection.
- Monthly operations
 - The planting of the salvaged material will be done in the same general area as the salvage operations. Exact location will be per the landscape plans.
 - Plant hole sizes and planting mixtures will be as shown on the plans.
 - Contractor shall coordinate planting and new irrigation with the general landscape contractor. The general landscape contractor will install the permanent irrigation system. The irrigation system must be functional within a week of tree installation.
- Cleanup
 - Contractor shall maintain the area of his work free from debris and extraneous material throughout the course of this work.

End of Section 02920

DIVISION 2 – SITEWORK

Section 02930 – Palm Tree Salvage and Planting

Introduction

This section contains standards for the identification, removal, storage and replanting of existing palm trees on site.

Part 1 - General

- Create a reference sheet for identification of trees to be salvaged.
- Provide backflow prevention devices for the temporary irrigation system if required by governing codes.
 - Holding Yard: The holding yard for this project will be on the project site, as indicated on the drawings. Water shall be provided by the Contractor.
- Identification of salvage material
 - The contractor, Architect and Owner's representatives will determine the final selection of salvage specimens based on specimens already identified, current health, accessibility, viability and appearance.
 - These trees shall be final-tagged with colored tape in conspicuous locations, irrigated, and fenced with temporary construction fence to avoid construction damage until they are removed.
 - Contractor is not to remove or work on any salvage material until after the Owner, or designated agent, has determined the limits of the salvage and work area, and has given the Contractor written consent to proceed.
- Removal of salvage material
 - Description of Work: The Contractor shall provide all labor, tools and materials necessary to remove salvage plants from the ground, frond- and rootball-protect them (when required) and transport them to the holding yard.
 - If it is determined that any of the trees to be transplanted can be immediately located to their new location, the Contractor may do so, but must water, maintain and protect the trees during construction.
 - If any trees are to be installed directly onto another site on UA property, the final site will need to be Bleu staked. Allow time for approval.
 - Access: Access shall be entirely within the Owner's property. Damage to surrounding areas not within the property, including but not limited to buildings, curbs, paving, vegetation and utilities, shall be the Contractor's responsibility.
 - The Architect will also identify areas within the property that are not to be disturbed. Any damage within these areas will also be the Contractor's responsibility. If designation of these areas makes access impossible, Contractor shall notify the Architect.
- Protection
 - Contractor shall provide barrier protection to warn pedestrians about the plant excavations, and reasonably prevent someone from falling into one.
 - Palms should be planted immediately or stored for no more than 48 hours in a shaded area where the total tree shall be misted frequently.
 - Do not store palm trees on an asphalt surface.
 - Covering material must allow air movement so that heat does not build up under the covering.
 - Do not use plastic or rubberized tarpaulins.
 - Do not stack palms, but lay them in a single layer on a flat surface.
 - If the trees are stored for more than a day, the rootballs must be covered with a burlap tarp and kept moist.
 - Planting delays may result in rejection of the palm.
 - Tagging and preparation:

- Exercise extreme caution while pruning palms, to prevent spread of vascular diseases. Dip pruning tools in a sterilizing agent before beginning pruning and before moving from one palm to another.
- After tagging of the palms, remove all thatch or dead leaves and cut back all resulting leaf bases to within 2 inches of the base of the trunk. Do not use chain type saws for pruning. Do not cut into trunk.
- The crown of the palm shall be reduced to leave at least 1/3 of the green fronds during shipping.
- Use soft rope (organic twine) to tie remaining fronds to protect crown bud.
- Do not permit fronds to become damaged by means of restraint.
- Loading and unloading:
 - A lattice type crane, a telescoping type crane or a specially designed tree crane is acceptable for lifting and off-loading palm trees.
 - For transporting, the trailer used shall be long enough to avoid damage to the heart of the palm.
 - Loading and unloading of palms must be accomplished with the aid of nylon or fabric sling/straps with a minimum width of 4 inches.
 - Palms should be carefully lifted off the truck setting the choker to the outside so to turn the palm to the inside as it is lifted.
 - Extreme caution must be used to ensure that the heads are not caught, pulled on banged into or shaken; any of these can damage the bud.
 - Excessive scarring or trunk damage will not be permitted and will be cause for rejection of the palms at the project site.
- Coordination
 - Remove all debris, trash and excess materials found on site or generated by the Contractor's operations.
 - Prior to digging and transplanting of palm trees the Contractor shall notify the Owner's Representative at least two (2) working days before starting any work.
 - Contractor is to provide all water and coordinate between temporary and permanent irrigation systems.
- Warranty
 - The Contractor shall warranty plants from damage caused by his own operations including boxing, holding and replanting. This warranty includes breakage of major limbs (after trimming), destruction of major root systems, excessive scarring to the trunk, and death from stress or severe insect damage.
 - Should replacement material be required under this warranty, Contractor is responsible for the procurement and transportation of the replacement material.
 - Plant materials shall be guaranteed for one year following final acceptance of planting operations under this section.
 - Guarantee nursery-grown palms against the bud rot *Thielaviopsis paradoxa*, the fungus *Fusarium oxysporum*, and the root disease *Phytophthora palmivora* and similar vascular infections for a period of six months from the start of the beginning of the maintenance period.
 - Replace without additional cost to the Owner all dead palms and all palms not in a vigorous condition as determined by the Owner's Representative. Replacement shall be when directed by the Owner's Representative.
 - Apply "Subdue" per manufacturers recommendation by flooding the planting basin as often as label permits during maintenance period.
 - Coordinate irrigation requirements of new palms with irrigation plans. The Contractor shall maintain the existing landscaping and irrigation systems.
 - Perform tensiometer testing and visual inspection of observation vents regularly during the maintenance period to verify the correct soil moisture at the surface and at the bottom of the rootball, report levels to the Owner's Representative in writing monthly.
 - Fertilize and apply soil and foliar drench.
 - Do not trim any green or partially green fronds during the maintenance period.

Part 2 - Products

- Palm trees
 - All palms shall have been grown in accordance with good horticultural practices under climatic conditions similar to those for the project for at least two (2) years prior to shipment to the site.
 - All palms shall be specimen quality, well-grown, symmetrical, without curvature or leaning trunk from the

perpendicular and so trained or favored in development and appearance as to be superior in form, compactness and symmetry of crown. All palms shall be within one foot above or below the height specified, measured from the bottom of the crown bud to finish grade after installation.

- All palms shall be sound, healthy and vigorous, well foliated prior to pruning and showing no signs of disease. They shall be free of disease, insect pests, eggs or larvae. They shall also have well developed root systems. All palms shall be free from physical damage or adverse conditions which would prevent thriving growth.
- Verify that all field dug palms contain an adequate root ball to guarantee transplantation. Do not wrap root ball in plastic. Do not install palms that have damaged root balls.
- Minimum box size, minimum trunk caliper, and initial height are identified under each tree species.
- For palm trees only, the height shall be measured from the ground line to the base of the growing bud.

- Accessories
 - Clean washed concrete sand.
 - Frond Tie: Minimum 1/2 inch diameter soft sisal rope capable of maintaining frond in tied condition for 4 months.
 - PVC Pipe: Schedule 40, 4 inch diameter perforated pipe.
 - Filter fabric for covering PVC perforated pipe.

- Fungicides:
 - Where a product trade name or company is listed, "or equal" substitutions may be offered.
 - Soil Drench: "Subdue" by CIBA-GIEGY.
 - Foliar Drench:
 - "Kocide" Copper T.S. fungicide.
 - "Manzate", dithane flowable fungicide.
 - "Benelate" fungicide.

- Fertilizers and amendments
 - Where a product trade name or company is listed, "or equal" substitutions may be offered.
 - "Wood-Ace" Palm Special fertilizer (11-4-6) as manufactured by Vigoro Industries.
 - "Soluble Stem" micronutrient fertilizer as manufactured by Peters Fertilizer Products of W.R. Grace and Company, Fogelsville, PA 18051.
 - "Minor-Gro" fertilizer as manufactured by W.R. Grace and Company, Fogelsville, PA 18051.
 - Hydrated urea.
 - "Basic H" as manufactured by Shaklee Corporation.

- Water
 - Clean, fresh, and free of substances or matter which could inhibit vigorous growth of plants.
 - Water shall not contain elements toxic to plant life.

Part 3 - Execution

- Existing palm tree removal/salvage
 - Existing palms designated for removal shall be excavated, prepared for salvage, and tree- and rootball-protected.
 - Rootballs of existing palm trees to be transplanted shall have a minimum diameter of the trunk diameter plus 4 feet, and shall be at least 16 inches in depth.
 - Contractor shall protect existing plant material, walls, pavements, and other site amenities from damage.

- Excavation
 - A trenching machine, a backhoe with a narrow bucket or a properly sized tree spade is acceptable as the excavation equipment. The exact equipment used must be approved by the Owner's Representative.

- Execution of planting new palm trees
 - Layout palms at locations shown on the plans. Use 3 foot lath, color coded for each palm. The Owner's

Representative will check location of palms in the field to exact position before planting begins.

- Where palms are to be preplanted to permit site improvements to be installed around them, be responsible for the accurate layout of those palms, measured to their centerlines.
 - Provide protection of those palms while work is taking place. Provide bracing per drawings.
 - Provide regular irrigation as necessary until final acceptance. Vitamin B-1 shall be used per manufacturer's recommendations with the first watering.
 - Excavation
 - "Hand dig" planting pits and protect existing utilities, where utilities may be encountered.
 - The palm tree excavation shall be a minimum of 5 feet wide by 5 feet long By depth of rootball plus 12 inches.
 - It is acceptable for the final site grade around the palm to be 6 to 12 inches higher than the original soil line of the root ball.
 - The depth of the pit shall be approved by the Owner's Representative prior to planting the tree.
 - Water-test tree pits:
 - Water test each tree pit for drainage by filling the holes twice in succession with water.
 - If when filled with water the second time the pit fails to drain within 24 hours, then additional excavation is necessary to break through the impermeable layer or to provide a thick under layer of clean washed concrete sand below the root ball.
 - Clean moist washed concrete sand should be added to the bottom of the hole and tamped or water jetted, prior to insertion of the tree.
 - Install drainage and viewing vent pipe(s) in each tree pit to assure wetting of the whole root ball and to enable monitoring and viewing of the tree pit chamber.
 - The vents shall be 4 inch diameter perforated PVC, with sufficient length to extend to the bottom of the tree pit. Provide filter cloth to cover perforated PVC pipe.
 - Do not backfill drainage or viewing pipes.
 - Backfill shall be clean site soil. Palms shall be placed in the pit and watered in as they are backfilled. Watering shall be done with a pipe sticker, six foot length topped with a 90 degree elbow and placed on the end of at least a 3/4 inch hose with adequate volume. Work the sticker up and down, washing the soil down around the rootball as the backfilling is accomplished. The backfill soil shall be thoroughly saturated, all around the periphery of the root ball, before going on to the next palm. It is of the utmost importance that this procedure occur as each palm is being planted, not later in the day, or the next day.
 - Apply fertilizer amendments during planting by mixing one ounce of "Basic H" and two tablespoons of "Stem" in a 5 gallon container of water. Drench area around each palm when backfilling is almost complete. Water in thoroughly.
 - A 6 inch deep swale shall be made around each palm tree to provide water holding capability.
 - After planting, the crown buds of all the palms shall be within 1 foot of the designated palm height above finish grade.
- Fungicide
 - After planting, drench the soil with the fungicide, "SUBDUE" per manufacturers recommendations by flooding the planting basin. Reapply as often as label permits throughout the maintenance period.
 - Irrigation
 - It is essential that irrigation be deep enough to assure wetting of the whole root ball. Vitamin B1 shall be used per manufacturer's recommendations with the first watering.
 - Maintain the irrigation system to the existing trees and supplement additional water to newly planted trees as necessary for establishment.
 - Check for water penetration as well as drainage throughout the root zone at least once a week and monthly thereafter for duration of warranty. These findings shall be entered into a log with the dates and initials of person verifying the drainage. Monitoring shall be done the day prior to applying supplemental water. After the initial watering-in, water the palms with a good soaking, 40-50 gallons per palm every day. Watering amounts and schedule are estimates and are subject to change by Owner's Representative after reviewing the log and observing in the field.
 - Fertilizing
 - After four to six weeks, apply four pounds per palm tree and at six month intervals apply 5 to 6 pounds per

- palm tree of "Woodace Palm Special" fertilizer in a one inch band around the base of each palm.
- After 14 days then monthly, spray the fronds (foliar drench) with the following mixture. No compounds shall exceed manufacturers recommended rate. The following rates are for a 100 gallon tank mix.
 - "Kocide" 101 w.p. at 3/4 pound; or "Manzate" at one quart.
 - W.R. Grace, "Minor-Gro" at 1/2 cup.
 - Hydrated urea and five cups or 2-1/2 pounds.
 - Spread sticker at 8 ounces "Basic H", by Shaklee Corp., Hayward California.
 - "Benlate" at one pound.

End of Section 02930

DIVISION 3 - CONCRETE

Section 03310 - Structural Concrete

Introduction

Drawings shall be coordinated between the various other sub consultants to avoid field problems with openings, shear walls and structural slabs. Drawings shall show special reinforcement required at openings. Drawings shall show location of construction, expansion and contraction joints.

Part 1 - General

- ACI references shall be comprehensive to cover the requirements needed.
- For special or critically flat floor slabs- use FF & FL numbering system set forth in ACI117 & ASTM E1155 for floor flatness/levelness.

- Concrete testing
 - Less than 50 cu yds - by Contractor
 - Greater than 50 cu yds - by U of A with a retesting charge for concrete not meeting specification.

- Mock-up should be provided for any structural concrete that is to receive a finish treatment such as a sandblasted, exposed aggregate or bush hammered finish. Any special finish treatment should be specified in Section 03330 Architectural Concrete. Mock-up shall not be incorporated into the final work.

Part 2 - Products

- Form materials. Metal or wood should be specified.
 - Wood forms: Specify grade and thickness of plywood form material. Limit reuse to 3 times
Exposed concrete - Use HDO plyform.
Unexposed concrete - Use AC plywood.
 - Column forms: Specify metal, fiberglass or sonotube (lined or unlined). These types are not equal.
Seam placement should be considered to insure workmanship-like patch if in finished area.
 - Pan forms. Specify specific type (steel, glass-fiber or reinforced plastic). These types are not equal and provide different finishes. Although discouraged, if underside is to be left exposed, pans are to be in "like new" condition.
 - Fiberglass grip form ties shall not be allowed.

- Rebar - if required to be welded, the appropriate type should be specified.

- To alleviate flooring material concerns associated with moisture transmission and emission through concrete slabs on grade the following preventive measures shall be prescribed.
 - A minimum 10 mil under slab vapor barrier shall be specified and detailed directly under the concrete slab and on top of any subgrade or sand grading material to minimize moisture transmission through the slab. Vapor barriers shall meet the requirements ASTM E-1745 Class "C".
 - A low water to cement ratio, low slump concrete should be specified for all interior slabs where flooring is anticipated to minimize the amount of free water in the concrete. Sufficient time should be allowed with the project to allow the emission of any free moisture to evaporate from the slab.
 - Surface sealers may be considered for re-flooring applications on existing slabs.

- Curing compounds and form release agents shall be non-staining and be compatible with the wall and floor finishes specified. Once selected for a project, they shall be used for the entire project.

- Sealers on exposed interior concrete floors shall be compatible with Johnson Wax Carefree and High Mileage. Refer to Section 09000 for additional discussion and considerations.
 - Penetrating sealers (silicon, epoxy, etc.) shall not be used when a custodial effort is intended to maintain the finish of the floor.
 - Sealer or finish should be applied immediately after the dissipation of the curing compound in order to protect floors during construction and then cleaned and reapplied prior to final acceptance.
- Minimum concrete compressive strength shall be 3000 psi for interior slabs on grade. Exterior sidewalks and slabs can utilize 2500 psi concrete. All concrete shall be specified by architect or engineer. Provide a detailed concrete mix schedule if more than one strength or type is required for the project.

Part 3 - Execution

- Column penetrations through slabs shall initially be blocked out in a diamond shape and infilled afterwards.
- Sandblasted or exposed aggregate finishes should be specified in Architectural Concrete. To achieve a uniform sandblast finish, special concrete mixes and forming practices are required, i.e., water tight forms.
- Slabs shall be depressed (dished) ½" deep around all floor drains.
- Provide 1 inch high dam at floor sleeves in wet walls and in wet locations above ground level.
- Provide visible post tensioned stamp in concrete at electrical and mechanical rooms located at post tensioned concrete slabs.
- Specify concrete testing for concrete at "point of placement" per ACI Section 301-20 Execution 4.3.2 and conforming to the requirements of ASTM C 94.

End of Section 03310

DIVISION 3 - CONCRETE

Section 03330 - Architectural Concrete

Introduction

In general, all of the items included in Section 03310 - Structural Concrete, will apply. This section shall be included when concrete will be exposed and special finishes may require non-standard formwork, special design mixes (for color or texture) and services of a specialized consultant to assist the Contractor in providing the required design results.

All of the above items should be considered if special finishes are desired. Attempts to get them without the benefit of special attention and/or an expert in this field will result in poor quality, compromised design and possibly additional charges on the part of the Contractor in connection with efforts to provide what was not specified or detailed.

Drawings must be very specific concerning the detailing for Architectural Concrete. The special features should be noted in the specifications and on the drawings. Descriptions such as "glass like", "polished", "light sandblast" finishes are considered as being ambiguous unless adequately specified in this Section.

Part 1 - General

- Typical examples of work in this section include exposed aggregate surfaces (whether water washed or sand blasted), bush hammered, textured, colored, and specialized forming.
- Requirements for structural concrete work are not to be used for Architectural Concrete. Reference ACI Standards.
- Submittals shall be required as appropriate for color additives, aggregate, formwork details, special form ties, curing agents, retarders, form release agents and the like. These items will all effect the final appearance of the concrete.
- Mock-ups shall be required for approval before work is incorporated in the building. Size and configuration of the mock-up is important to fully evaluate all anticipated construction details. Mock-up shall not be incorporated into the final work.

Part 2 - Products

- Generally, architectural finish on concrete is associated with watertight formwork.

Part 3 - Execution

- Anticipate the fact that sandblasting is a very disruptive and messy activity that is not easily accomplished in many areas of campus. Compliance with Pima County air pollution standards will also be a requirement of the specification.

End of Section 03330

DIVISION 4 - MASONRY

Section 04200 - Unit Masonry

Introduction

Red brick is used almost exclusively for exterior masonry elements and its appearance is important toward maintaining campus unity.

Part 1 - General

- For all new and infill masonry work adjacent to existing walls, require that a 3' x 3' mock up wall be constructed to insure that both the brick and the cured mortar colors are satisfactorily matched. Require minimum of 3 week curing time for evaluation of the mortar color.
- On new construction a similar appropriately sized mock up should be constructed to establish the standard of acceptance for all elements of the work, i.e., mortar color, flashing, coursing, pattern, control joints, accessories, etc.
- The tops of all exposed masonry walls shall receive a watertight cap, i.e., sheetmetal or precast concrete, to prohibit moisture infiltration and efflorescence.
- To minimize brick color variations, the project should be fired and supplied in one continuous run. If variations in color exist within the run, the differently shaded bricks shall be randomly intermixed as the wall is constructed. Obvious delineations in the brick color are not acceptable.

Part 2 - Products

- Selected brick color shall be as available from local southern Arizona suppliers.
- The use of mortar or grout admixtures, other than color pigments, shall not be allowed. Specifically prohibit the use of any mortar retarding agents due to their unpredictable nature.
- Mortar shall be consistently batched. Use pre-mix from batch plant or use gauge boxes on-site. The use of the shovel method for measuring and batching mortar mixes should be discouraged.

Part 3 - Execution

- Tolerances: Masonry work that does not conform to the following tolerances shall be repaired or replaced as directed by the Architect. Tolerances are based on ACTUAL DIMENSIONS.
 - Variations from plumb:
 - In lines or surfaces of columns, walls, and arises: in 10 feet - $\frac{1}{4}$ "; in any story or 20 feet maximum - $\frac{3}{8}$ "; in four stories or more - $\frac{1}{2}$ ".
 - For external corners, control joints and other conspicuous lines: in any story or 20 feet maximum - $\frac{1}{4}$ "; in 40 feet or more - $\frac{1}{2}$ ".
 - Variations from the level or the grades indicated on the drawings:
 - For exposed lintels, sills, parapets, horizontal grooves and other conspicuous lines: in any bay or 20 feet maximum - $\frac{1}{4}$ "; in 40 feet or more - $\frac{1}{2}$ ".
 - Variation of the linear building lines from established position in plan and related portion of columns, walls and partitions:
 - In any bay or 20 feet maximum - $\frac{1}{2}$ "; in 40 feet or more - $\frac{3}{4}$ ".

- Variation in cross-sectional dimensions of columns and in the thickness of walls is plus or minus $\frac{1}{4}$ ".
- The type of mortar joint should be specified. Tooled joints are preferred. Raked and flush joints are discouraged.
- Masonry anchoring
 - Anchor spacing to structural members shall be indicated, but not more than 24"o.c. vertically and 36"o.c. horizontally.
 - Anchor spacing to metal studs (single wythe masonry) shall be indicated, but not more than 16"o.c. vertically and 24"o.c. horizontally with not less than one anchor for each 2 sq. ft. of wall area. Install additional anchors within 1'-0" of openings and at intervals around perimeter not exceeding 8".
- Control Joints

Install control and expansion joints in unit masonry at 20' maximum. Joint width shall be not less than $\frac{3}{8}$ " for installation of backer rod and sealant.
- Lintels

Provide masonry or steel lintels where shown and/or wherever openings are more than 1'-0" wide for brick size units and 2'-0" for block size units. Provide steel, precast or formed-in-place masonry lintels for all larger openings. Cure precast lintels before handling and installation. Temporarily support formed-in-place lintels.

End of Section 04200

DIVISION 5 - METALS

Section 05300 - Metal Decking

Introduction

Metal decking is a straightforward structural specification with limited University requirements.

Part 1 - General

- Specify type of attachment to structure, i.e., screws or puddle welding.
- Be aware that many metal deck manufacturers do not allow attachment of suspended loads to the underside of their metal deck. Unless engineered differently, all ceiling, framing, mechanical, plumbing and electrical supports shall be attached to the structural framing members only.
- Verify that metal deck priming or galvanizing is compatible with fireproofing when applicable.

Part 2 - Products

- There are no unique University requirements.

Part 3 - Execution

- There are no unique University requirements.

End of Section 05300

DIVISION 5 - METALS

Section 05500 - Metal Fabrications

Introduction

This Section applies to all miscellaneous metal items such as lintels, embeds, grating, ladders, handrails, stairs, bollards, nosings, trim and similar architectural features.

Part 1 - General

- Metal pipe bollards shall be a minimum of 6" diameter.

Part 2 - Products

- Metal bar grating shall be capable of withstanding a minimum uniform load of 250 psf or a concentrated load of 650 lbs.
- Grout and anchoring cement shall be non-metallic, non-shrink type.
- Consider abrasive metal stair nosings for all stairways especially those that are exterior.

Part 3 - Execution

- Welds shall be ground and sanded smooth for uniform painted appearance. The use of "Bondo" to fill large gaps and holes is discouraged.
- All sharp corners shall be radiused a minimum of 1/8"
- The use of expansion bolts to secure metal railing assemblies is discouraged. Anchorage should consist of direct embeds (cored holes, sleeves or plates) and/or welding.
- The use of metal pans for exterior stairs is discouraged and shall only be used with the approval of the UA Project Coordinator. When used in an exterior application all metal pans and other associated metal stair components shall be galvanized or 100% seal weld with all metal pan surfaces epoxy painted prior to infilling with concrete to alleviate the development of rust on any hidden or confined surfaces.

End of Section 05500

DIVISION 5 - Metals

Section 05700 – Ornamental Metals - Skateboard Deterrents

Introduction

Destruction and degradation of architectural edges due to skateboarders, skaters and BMX bicycles is an ongoing problem at the University. Where possible, integrating deterrents into the architectural design is preferred. This can be done many different ways - with uneven edges, recesses, ground textures, railing design etc. Otherwise, specify appropriate metal skateboard deterrent systems whenever edges and surfaces create temptations. The University recognizes that not all conditions that create opportunities for skateboarders, skaters & BMX'ers can be foreseen or prevented.

Part 1 - General

- Generally, railings, concrete edges, brick edges, tile edges, concrete benches, seatwalls, and protruding ledges should be evaluated for application.

Part 2 – Products

- Metal Skateboard deterrents – past projects have utilized products from Barco Products. Similar products from other manufacturers may also be specified.

Barco Products
1-800-338-2697
www.barcoproducts.com

Part 3 – Execution

- No discussion

End of Section 05700

DIVISION 6 - WOOD AND PLASTICS

Section 06000 - General Discussion

Introduction

This General Discussion Section contains material which is important to successful millwork, wood framing and wood structural installations, in construction projects. The issues are fundamental to the basic design of the project, and the long term success of those elements of the project, as well as the fabrication and installation process.

General Carpentry and Wood Design

Although not a material of choice for exposed conditions in our desert climate, wood is used extensively as a building material. When used in University projects and in structural conditions requiring structural design and/or calculations, Consultant shall use a professional structural engineer currently registered in Arizona. Installations shall be by contractors and tradesmen skilled in framing and carpentry work.

Architectural Woodwork / Custom Casework

Because the University anticipates a longer than average building life and higher than average use and abuse, durable, high quality architectural woodwork (millwork) is essential to the long term success and serviceability of any project. Section 06402 - Architectural Woodwork / Custom Casework specifies current Standards of the American Woodworking Institute (AWI) but modifies the standard to omit the use of certain materials in certain conditions and in certain portions of the work. Although used extensively industry wide, in the experience of the University, these materials have proven unsatisfactory and must be specifically excluded from the specifications.

Laboratory Casework

These Standards differentiate between Architectural Woodwork / Custom Casework and Laboratory Casework because of the specialized nature and use of the product. Laboratory Casework shall be specified separately in **Division 12 Furnishings**. Additional standards are cited and specific pre-approved fabricators and manufacturers are listed. Also, it may be necessary to include additional sections in **Division 11 Equipment** to cover acrylic counter tops, laboratory bench tops and surfaces for acid and chemical resistance and for Laboratory Fixtures.

End of Section 06000

DIVISION 6 - WOOD AND PLASTICS

Section 06100 - Rough Carpentry

Introduction

No Discussion

Part 1 - General

- Submittals shall not be required if drawings sufficiently describe products unless special attention is desired by the Consultant, or the Project Manager.
- Submittals requiring structural design or calculations shall be sealed by a professional structural engineer currently registered in Arizona.
- Indicate and coordinate on plans and specifications all required solid blocking at all wall hung fixtures, door stops, cabinets, shelves and similar items.

Part 2 - Products

- Roof sheathing shall be a minimum of 5/8" thick, Exterior Plywood over trusses or joists at 16" or 24" spacing. At 24" spacing "ply-clips" shall be required.
- Fire Retardant Treated Lumber and plywood shall be specified and provided as required by Code and construction type.

Part 3 - Execution

- Installations shall be by contractors and tradesmen skilled in carpentry work.

End of Section 06100

DIVISION 6 - WOOD AND PLASTICS

Section 06170 - Pre-Fabricated Structural Wood

Introduction

No Discussion

Part 1 - General

- Submittals shall be required for all prefabricated wood trusses including shop drawings, erection drawings, bracing and calculation.
- Submittals requiring structural design or calculations shall be sealed by a professional structural engineer currently registered in Arizona.

Part 2 - Products

- Trusses with metal webs and laminated timber top and bottom chord members are preferred, and joists, other than dimension lumber, are preferred to be the plywood web type with laminated wood top and bottom chord members. "Gang-Nail" type trusses are discouraged.
- Glue Laminated structural members shall conform to the standards of the American Institute of Timber Construction (AITC). Designer must take care to differentiate between appearance and concealed grades of structural members.

Part 3 - Execution

- Installations shall be by contractors and tradesmen skilled in carpentry work.

End of Section 06170

DIVISION 6 - WOOD AND PLASTICS

Section 06200 - Finish Carpentry

Introduction

Consideration shall be given to the use of wood base, in lieu of the usual rubber base, in high use areas where equipment might impact and damage walls. Also consider chair rails for wall protection where appropriate.

Part 1 - General

- Finish Carpentry and Interior Architectural woodwork shall be fabricated to current Standards of the American Woodworking Institute (AWI). In most circumstances the requirements of "Finish Carpentry" may be combined with Section 06402 - Architectural Woodwork rather than in a separate section.

Part 2 - Products

- All Architectural Woodwork shall be "Custom" grade (or better as may be required) according to the American Woodwork Institute (AWI) and subject to the following:
 - No particle board or particle board core plywood may be used in any part of the work.
 - Plywood shall be industrial quality.

Part 3 - Execution

- Installations shall be by skilled tradesmen. In the cases where fabricator and installer are not one and the same, product and project guarantee shall not be compromised.

End of Section 06200

DIVISION 6 - WOOD AND PLASTICS

Section 06402 - Architectural Woodwork / Custom Casework

Introduction

These standards differentiate between Architectural Woodwork/Custom Casework and Laboratory Casework because of the specialized nature and use of the product. Laboratory Casework shall be specified separately in **Division 12 - Furnishings**. The term Woodwork is used throughout this section to refer generically to both woodwork and casework.

Part 1 - General

- Reference the following standards as applicable:
 - AWS, Architectural Woodwork Standards, current edition.
 - ANSI/BHMA A156.9 – Cabinet Hardware.
 - NEMA LD3 – High Pressure Decorative Laminate.
- In most circumstances the requirements of Section 06200 - Finish Carpentry may be combined with this section rather than issuing a separate section.
- Develop specifications for other related materials such as stone or quartz tops, metals, plastics, etc., that might be used in conjunction with woodwork/casework.

Part 2 - Products

- At most locations Architectural Woodwork shall be AWS “Custom” grade. Use AWS “Premium” grade at high profile locations such as reception areas, executive suites, board rooms, museums and libraries. . Architectural Woodwork is also subject to the following additional criteria:
 - No particle board or particle board core plywood may be used in any part of the work, and shall be specifically excluded. .Plywood or high grade medium density NAUF (no added urea formaldehyde) wood fiber board (MDF) may be used for cabinet doors and drawer fronts. Plywood shall be all hardwood veneer core.
 - Wood drawer and door fronts are to be finished with an 1/8” solid wood edge band.
 - Laminate drawer and door fronts to be finished with a 3 mm PVC edge band.
 - High density NAUF (no added urea formaldehyde) wood fiber board may be considered for use in lieu of plywood for laminate tops in dry areas if approved by the Project Manager.
 - Water resistant medium density fiberboard may be considered for damp areas if approved by the Project Manager.
 - Woodwork shall be opaque or transparent finish rotary cut uniform color light birch hardwood (unless otherwise approved by the Project Manager), or plastic laminate; review with UA Project Manager for final selection. Architect shall specify finish and call for sample submittal for review and approval.
 - Doors and drawers with plastic laminate finish shall be fully clad including inside faces of doors .
 - Minimum grades for plastic laminates shall be as follows (NEMA / Inch Thickness): For horizontal surfaces use HGS/.048 or HGL/.039, and for vertical surfaces use VGS/.028.. Comply with International Standards Organization (ISO) 4586.
 - Cold rolled laminate is not permitted.
 - Thermofused high pressure melamine or plywood are allowable for cabinet interiors. For wood, finish interior to match exterior.
 - Plastic laminate tops and back splashes are to be fabricated using 3/4” plywood unless approved otherwise. Edges and joints shall be tight, glued and sealed. Post formed tops and splashes are not allowed. In those areas where sinks are applied to the underside of counter tops, the tops shall be fabricated from 7 ply birch plywood (3/4” minimum) with an “A” surface one side. Do not use water based laminate glues on any counter top.
 - All doors shall be balanced with the same material on the back side of door as is used on the front side.
 - Backer shall be provided on all counters for balance.

- Approved manufacturers of plastic laminate are:
 - Wilsonart
 - Formica
 - Nevamar
 - Pionite

- Approved manufacturers of Solid Surfacing Material Tops are:
 - Corian
 - Formica Solid Surfacing
 - Samsung Staron
 - Avonite
 - LG HiMac

- Hardware shall be indicated in a schedule in this section or in Section 08710, Finish Hardware. If in Section 08710, reference to that section.
 - Drawer glides shall be full extension heavy duty rated.
 - Hinges shall be concealed type full metal with manufacturer's lifetime warranty.
 - Hardware for adjustable shelves on walls shall be Heavy duty KV standard and bracket system, or equal.

- Approved hardware manufacturers are:
 - Pro Mark
 - McKinney
 - Knape and Vogt
 - Blum
 - Stanley
 - Grass America
 - Hafele
 - Salice

Alternate woodwork products could be considered if reviewed with UA Project Manager.

Part 3 - Execution

- Fastening devices and their attachment shall be submitted for approval prior to installation. Drywall screws will not be allowed for the attachment and installation of millwork.

- All concealed surfaces of woodwork/casework shall be treated at the shop with spray or brush application of low emitting clear finish. In the field all concealed scribed and cut surfaces shall receive a brush application of the same material.

- Drawers shall be lock shouldered or multiple dovetailed and have applied fronts. Bodies shall be hardwood or 7 ply plywood. Bottoms shall be hardwood panel product full or stop dadoed. Exposed surfaces shall be hardwood. All drawers shall ride on full suspension drawer glides, not wood keels. As an option, drawers may be 5/8" thermofused high pressure melamine with doweled construction.

- Shelves shall be edged plywood or solid lumber. Janitor and storage room shelving may be "Economy" grade laminate clad MDF. Particle board is not allowed.

- Indicate requirements for utility provisions which must be coordinated by the fabricator.

- Plastic laminate application shall be specified as follows:
 - Apply side edging first, then top surface, with top surface overlapping side edging.
- Installations shall be by skilled tradesmen. In the cases where fabricator and installer are not one and the same, product and project guarantee shall not be compromised.
- Follow manufacturer's instructions for installation of solid surface, taking special care to adhere to recommendations for seams and supports.
- Large woodwork installations shall be certified using WI.
- Acclimate woodwork in climate controlled environment prior to installation, per AWS.

End of Section 06402

DIVISION 7 - THERMAL AND MOISTURE PROTECTION

Section 07000 - General Discussion

Introduction

This General Discussion Section contains material which is critical to successful moisture protection systems in new construction and renovation, but which is not the sole responsibility of any individual trade. In many cases, the issues involved are fundamental to the basic design of the project, and the success or failure of the moisture protection concept is determined at the very outset of the design process.

The Consultant is expressly responsible for incorporating these overall requirements into the project, and for ensuring that all subconsultants are aware of the requirements and incorporate them into their designs as well.

Reliance on "after-the-fact" material selections to compensate for a problematic design decision is unacceptable.

Below Grade Spaces

- Below grade spaces are high-risk, expensive designs. Wherever possible, avoid
 - The use of finished below grade spaces requiring drainage systems and wall waterproofing
 - Planters above or adjacent to basement areas
- PDC actively discourages below grade elements in University projects. Designs incorporating below grade finished spaces will receive the strongest scrutiny during the programming and conceptual design phases. Be prepared to thoroughly document the unavoidable need for such elements.
- The University has experienced numerous instances of subsurface moisture working through concrete floor slabs on grade and destroying floor finishes. This seems mostly to be problem with below grade spaces. Ground floor slabs on grade have, so far, been safe from this condition. To ensure that this situation does not arise again, provide an impermeable moisture barrier under all slabs on grade.
- Wherever below grade walls are exposed to naturally flowing groundwater or substantial landscape irrigation water, even if simply foundation walls, include a foundation drainage system in addition to dampproofing or waterproofing the walls.

Traffic Decks

- Traffic bearing decks are very difficult and expensive to successfully waterproof and maintain. Wherever possible, avoid use of finished spaces with traffic decks exposed to the weather above them.
- PDC actively discourages use of such elements in University projects. Designs incorporating horizontal traffic decks will receive the strongest scrutiny during the programming and conceptual design phases. Be prepared to thoroughly document the unavoidable need for such elements. Failing such documentation, the Consultant will be directed to revise or even start completely anew the design.
- Special attention should be given to ensure that all horizontal traffic surfaces provide appropriate slip resistance.

Roof Design

- Do not design roofs which are intended to serve as walking surfaces for user functions. Activities which must be conducted on the roof top (e.g. astronomical or weather observations, greenhouses, etc.) require a design which incorporates platforms, penthouses or similar special enclosures.
- Similarly, do not design roofs which are required to be used as working platforms for maintenance of mechanical and electrical equipment. Enclose such elements in a penthouse.

- Avoid wherever possible use of conduit and piping installed on top of the roof.
- Any mechanical or electrical equipment which must be installed on the roof must be installed on either a prefabricated curb or a field fabricated platform. Where the top surface of such curbs and platforms is not completely covered and waterproofed by the actual equipment, the top surface must be a solid sheet metal cap. Design must meet OSHA workspace and fall precaution criteria.
- Installation of any type of roof top mechanical or electrical equipment on sleepers is not acceptable.
- Wherever possible, make the basic roof slope, and the slope of the crickets to the drains, part of the structural system (slope the structure). When impossible or impractical to induce slope into the structure, care should be taken in the selection of tapered rooftop insulation and rigid overlayment board to insure a durable roof surface that will hold up to maintenance activities for the life of the roof and will not compress over time under various loads.
- Dead flat roofs are not acceptable.
- Design for a slope of 3/8" per foot, throughout the field of the roof and for all crickets, at the time of construction. Ensure that anticipated deflections and proposed cambers will result in a minimum slope of 1/4" per foot throughout the life of the facility.
- Space drains so that slopes in cricket valleys are at least 1/8" per foot.
- Provide metal or wood framing and sub-framing for large crickets. Cricket surfaces must be able to accept live loads similar to those of the basic roof deck.
- Small crickets up-slope of equipment curbs must maintain 1/8" per foot slope in their valleys, and may be fabricated of tapered insulation, not to exceed 4" thick.
- Design the project to allow for one complete re-roofing without removal of the existing roof system, should the University decide to do so. This includes:
 - Structural load capacity
 - Camber and deflection
 - Parapet heights
 - Joints, drains, and flashings
- Ensure that the design makes adequate allowance for proper flashing of perimeters and penetrations. Sufficient vertical dimension to install the cant strip, base flashing, counterflashing, and coping, will result in a parapet at least 18" above the finished roof at the highest point of the roof slope. Include a specific detail in the construction documents. This includes:
 - Parapet walls
 - Partial roof structures
 - Equipment curbs and platforms
 - Door and window sills
- Do not assume that base flashings and counterflashing can be successfully nailed into concrete or masonry. Provide a 3/4" plywood nailer at all parapets.
- Do not use interior roof drains without the specific permission of the Project Coordinator. When unavoidable, provide positive overflow drainage, preferably with a scupper through the parapet wall to daylight, or with a complete separate parallel overflow drain system.
- Design all roof drains and overflow drains in a depressed sump.

- Reroofing must comply with the requirements for new installations as much as possible. The Consultant is responsible for preparing complete details and specifications for the required reroofing work.
- Roofing repairs (e.g. installation of a new exhaust fan), must comply with the requirements for new installations as much as possible. The Consultant is responsible for preparing complete details and specifications for the required repair work. Generic notes such as "flashing as required" are not acceptable. While the University is not interested in telling the Consultant whether the Architect or the Mechanical Engineer should prepare the details and specifications for this type of repair, the information must be thorough and complete regardless of the author.

End of Section 07000

DIVISION 7 - THERMAL AND MOISTURE PROTECTION

Section 07100 - Waterproofing and Dampproofing

Introduction

Waterproofing and dampproofing are not interchangeable materials. Project may have one, both, or neither.

Waterproofing is a relatively secure system, and is used on surfaces which enclose habited space and where moisture penetration is not acceptable.

Dampproofing is a less restrictive system, and is used to reduce moisture migration through exterior surfaces such as retaining walls and planters.

Where such surfaces are intended to be subject to foot traffic, and therefore are not "roofs", refer to the requirements of Section 07590 Horizontal Traffic Surfacing.

Pay particular attention to the drainage course against the wall and to perimeter drains. Describe requirements for these elements on the drawings.

This is a section where the consultant should use a "performance specification". Do not specify proprietary manufacturer's names or materials, and do not restrict vendors to a limited list.

Part 1 - General

- Require that materials manufacturer(s) and installer(s) demonstrate 5 years of successful installations of similar systems.
- Require submittal of manufacturer's literature describing the system, and samples of proposed membrane materials.
- Require a pre-installation conference, scheduled after the substrates are complete, and including the Contractor, Architect, Owner, materials manufacturer, and installing subcontractor(s).
- Specify expanded warranties as follows:
 - 5 year warranty from the installer covering defects in installation
 - 10 year warranty from the materials manufacturer including defects in materials and installation, and guaranteeing to maintain the system in a waterproof or dampproof condition (as applicable) for the life of the warranty
 - Include sealing of all perimeters, joints, and penetrations
 - Renewal option for an additional 10 years from the materials manufacturer
 - Full replacement value without proration
 - Both furnished on the University's special warranty form

Part 2 - Products

- Expressly prohibit the use of asbestos-containing materials.
- Require that all materials be supplied by a single manufacturer, or approved by the primary materials manufacturer, to ensure single-point responsibility for the installation and warranty.
- Specify a waterproofing system which includes the following:
 - Joint preparation
 - Continuous self-healing sheet membrane, or

- Fluid-applied membrane which cures in place to form a continuous monolithic self-healing membrane
- Termite-resistant protection board embedded in a fluid-applied coating to prohibit displacement

- Specify a dampproofing system which includes the following:
 - Joint preparation
 - At least two layers of trowel-grade bituminous coating with interweaved mesh membrane reinforcement
 - Termite-resistant protection board embedded in bituminous coating to prohibit displacement

Part 3 - Execution

- Require that the in-progress installation be observed by the materials manufacturer to ensure that the complete assembly will qualify for the required warranty.

- Require that all penetrations be installed in the wall prior to membrane application, so they can be properly sealed by the membrane installer. Avoid the installation of unnecessary sleeves and pay particular attention to the detailing of those that are required.

End of Section 07100

DIVISION 7 - THERMAL AND MOISTURE PROTECTION

Section 07200 - Insulation

Introduction

This is a section where the consultant should use a "performance specification". Do not specify proprietary manufacturer's names or materials, and do not restrict vendors to a limited list.

This section includes insulation used for thermal purposes, and which is installed as an independent material. Insulation which is an integral of a specific system (e.g. membrane roofing or exterior insulation and finish systems), is described in the appropriate Sections.

Such insulation may be included in the total assembly R-value. However, such insulation must not be the sole source of thermal resistivity for the building.

Design building surfaces which experience a significant temperature differential across their thickness to meet the following thermal resistance ("aged R-value") criteria:

R-19 at walls

R-30 at roofs and exposed floors

Do not specify any form of insulation to be laid directly on accessible ceilings. Instead, detail horizontal insulation at the top of the cavity, and extend vertical insulation up to that level.

Part 1 - General

- Replace all insulation that becomes wet.

Part 2 - Products

- Expressly prohibit the use of asbestos-containing materials.
- Specify only molded or extruded polystyrene board, or fiberglass batt, insulation.
- With code required vapor barriers to be provided at exterior wall construction, specify required fiberglass insulation to be un-faced. Specify un-faced fiberglass insulation at interior wall locations needing insulation.
- Use blown-in insulations only in remodeling projects where the wall or ceiling/roof assembly is inaccessible for installation of board or blanket materials, and only with specific permission of the Project Coordinator.

Part 3 - Execution

- Specify mechanical attachment for all insulation. Do not specify insulation to be adhesive applied or installed loose.

End of Section 07200

DIVISION 7 - THERMAL AND MOISTURE PROTECTION

Section 07240 - Exterior Insulation and Finish Systems

Introduction

Use only Type PM (mechanically attached) systems. Use Type PB (adhesive applied) systems only with specific permission of the Project Coordinator.

Consider alternative exterior cladding systems in areas where the finish may be subject to physical abuse.

Indicate all required expansion, control, and design joints on the drawings.

Part 1 - General

- Require that all materials manufacturer(s) and applicator(s) demonstrate 5 years of successful installation of similar systems.
- Require that applicators be approved and licensed by the materials manufacturer. Use an approved applicator system as a test for manufacturer approval.
- Specify a special 5 year guarantee against defects in materials and installation; including attachment failure, delamination, cracking, peeling, and fading.
- Require mock-up.

Part 2 - Products

- Require that all materials be supplied by a single manufacturer, or approved by the primary materials manufacturer, to ensure single-point responsibility for the installation and warranty.
- Specify only extruded polystyrene insulation board, with Class A flame spread and smoke developed characteristics.
- Specify only acrylic-modified Portland cement adhesive and base coat.
- When required, specify only 100% acrylic, integrally colored finish coat, without the need for additional pigmented coatings.
- Where the system will be exposed to potential physical abuse, specify only manufacturers standard "high impact" components.
- Show control joint and expansion joint locations or require submittal of same.

Part 3 - Execution

- Specifically require the system to be installed in accordance with the manufacturer's recommendations.
- Require the applicators to maintain a "wet edge" until a natural break point is achieved. Expressly prohibit scaffold lines and cold joints.

End of Section 07240

DIVISION 7 - THERMAL AND MOISTURE PROTECTION

Section 07250 - Fireproofing

Introduction

Indicate on the drawings the UL Listing Number and fire resistance rating which is required for each condition of structural fireproofing.

Fireproofing systems which are part of a renovation project (e.g. repair of damaged or missing systems, or removal and replacement of existing systems) should follow these standards. Existing fire resistance ratings must not be compromised. The consultant must prepare a complete specification and details for the required repair work. Generic "repair fireproofing as required" notes are not acceptable.

This is a section where the Consultant should use a "performance specification". Do not specify proprietary manufacturer's names or materials, and do not restrict vendors to a limited list.

Part 1 - General

- Require that all materials manufacturer(s) and applicator(s) demonstrate 5 years of successful installation of similar materials.
- Require submittal of manufacturer's literature describing all materials, and the specific systems to be applied for this project.

Part 2 - Products

- Specifically prohibit the use of asbestos containing materials.
- When re-fireproofing structural elements where asbestos-containing fireproofing has been abated by the University, specify only materials which are known to be compatible with asbestos encapsulants.

Part 3 - Execution

- Describe requirements for protection of completed fireproofing.
- Describe specific requirements for repair of fireproofing in the event of damage.
- When re-fireproofing structural elements where asbestos-containing fireproofing has been spot-abated by the University, specifically describe precautions which the Contractor must take to protect adjoining asbestos-containing fireproofing which remains.

End of Section 07250

DIVISION 7 - THERMAL AND MOISTURE PROTECTION

Section 07270 - Firestopping

Introduction

Describe in this Section all requirements for firestopping wall penetrations, floor penetrations, ceiling penetrations, and joints. Do not rely on general references in the sealants section. This includes boards, blankets, modules, pillows, tapes, caulks, foams, intumescent, and other similar materials.

Specifically describe on the drawings all requirements for installation of firestopping. Generic notes such as "firestopping as required" are not acceptable. Reliance on the Contractor understanding the building code and "complying at no additional cost" is similarly not acceptable.

This is a section where the Consultant should use a "performance specification". Do not specify proprietary manufacturer's names or materials, and do not restrict vendors to a limited list.

Part 1 - General

- Require that materials manufacturer(s) and installer(s) demonstrate 5 years of successful installations of similar materials.
- Require submittal of complete manufacturer's literature, including UL test results for each material-and-application system required for the project.
- It is desirable to have all trades use the same product.

Part 2 - Products

- Specify each type of firestopping material required in the project.
- Product shall be trowable and paintable.

Part 3 - Execution

- Label all fire rated walls to include above concealed or accessible ceilings and below raised access floors. Minimum 3" red lettering shall say (1 or 2 Hr. Fire Rated). Depending on rating. Labeling to be a maximum 15' from end of walls and a maximum 30' O.C.
- Provide a schedule identifying location and type of firestopping.
- Require installation of sleeves at all wall, floor, and ceiling penetrations.
- Specifically require firestopping materials to be installed in accordance with the manufacturer's recommendations.
- Specifically require that all firestopping be observed as complete prior to being covered by other work.

End of Section 07270

DIVISION 7 - THERMAL AND MOISTURE PROTECTION

Section 07310 - Shingles

Introduction

Systems described in this Section are intended to be installed in situations where the roof slope is at least 4 inches per foot, and where the roofs are not intended to receive regular foot traffic for equipment maintenance.

Specify a complete roofing system, making the materials manufacturer responsible for the roofing and flashing system. Require the materials manufacturer to make periodic inspections of the work in progress to ensure that the completed work will qualify for the required warranties.

Do not use roof deck insulation as the only element in the overall building thermal resistance system. Refer to Section 07200.

This is a section where the consultant should use a "performance specification". Do not specify proprietary manufacturer's names or materials, and do not restrict vendors to a limited list.

Shingle roof repairs and modifications which are part of a renovation project (e.g. installation of a new exhaust fan) should follow these standards as much as possible. Existing roof warranties must not be compromised. The consultant must prepare a complete specification and details for the required repair work. Generic "flashing as required" notes (which often appear on engineering details for new exhaust fans) are not acceptable.

Be sure to coordinate specification requirements with roofing, flashing, and parapet wall details.

Part 1 - General

- Require that materials manufacturer(s) and installer(s) demonstrate 5 years of successful installations of similar systems.
- Require submittal of manufacturer's literature describing the system, and samples of proposed shingles.
- Require a pre-installation conference, scheduled after the substrates are complete, and including the Contractor, Architect, Owner, materials manufacturer, and installing subcontractor(s).
- Shingle roofing is a finish material, not a staging platform for further construction work. Include the following provisions:
 - Require the Contractor to install a "temporary roof" if he desires to "dry-in" the building to allow interior construction to begin or to provide a platform for further exterior construction
 - Describe this requirement as a "Contractor's Option", that is, if he wants to dry-in, he must do so only with a temporary roof
 - Reference the National Roofing Contractor's Association (NRCA) requirements for temporary roofs, including "sacrificial" insulation on metal decks
 - Specifically prohibit "phased roofing"
 - Require that finished roofs be protected with plywood sheets for any and all construction traffic, and that all equipment moving be accomplished with rollers
- Specify expanded warranties as follows:
 - 5 year warranty from the installer covering defects in installation
 - 30 year warranty from the materials manufacturer including defects in materials and installation, and guaranteeing to maintain the system in a waterproof condition for the life of the warranty
 - Full replacement value without proration

- Include all components of the roof assembly, from the deck up
- Include sealing of all perimeters, joints, and penetrations
- Both furnished on the University's special warranty form

Part 2 - Products

- Expressly prohibit the use of asbestos-containing materials.
- Require that all primary and secondary materials be supplied by a single manufacturer, or approved by the primary materials manufacturer, to ensure single-point responsibility for the installation and warranty.
- Specify a manufacturer's standard shingle roofing system as follows:
 - UL Class A fire rating
 - UL Class 90 wind uplift rating
 - Minimum 15-lb asphalt saturated underlayment
 - 30 year fiberglass-reinforced asphalt shingles
- Limit roof insulation to 2" thick. Specify insulations which provide adequate load-bearing capacity at the 2" thickness.

Part 3 - Execution

- Specifically require the roof to be installed in accordance with the manufacturer's recommendations.
- Refer to and describe the appropriate SMCNA details for each edge and penetration condition.
- Require the roofing installer to receive, accept, and install, all sheet metal flashings.
- Specifically prohibit:
 - Pitch pans
 - Guy wires fastened directly to the deck
- Specify (or detail) 3/4" plywood nailers at all parapet walls.
- Require a spray test after completion of the roofing system, to be witnessed by the Contractor, Architect, Owner, materials manufacturer, and installing contractor(s).

End of Section 07310

DIVISION 7 - THERMAL AND MOISTURE PROTECTION

Section 07320 - Clay Tile Roofing

Introduction

Systems described in this Section are intended to be installed in situations where the roof slope is at least 4 inches per foot, and where the roofs are not intended to receive regular foot traffic for equipment maintenance.

Specify a complete roofing system, making the materials manufacturer responsible for the roofing and flashing system. Require the materials manufacturer to make periodic inspections of the work in progress to ensure that the completed work will qualify for the required warranties.

Do not use roof deck insulation as the only element in the overall building thermal resistance system. Refer to Section 07200.

This is a section where the consultant should use a "performance specification". Do not specify proprietary manufacturer's names or materials, and do not restrict vendors to a limited list.

Clay tile roof repairs and modifications which are part of a renovation project (e.g. installation of a new exhaust fan) should follow these standards as much as possible. Existing roof warranties must not be compromised. The consultant must prepare a complete specification and details for the required repair work. Generic "flashing as required" notes (which often appear on engineering details for new exhaust fans) are not acceptable.

Be sure to coordinate specification requirements with roofing, flashing, and parapet wall details.

Part 1 - General

- Require that materials manufacturer(s) and installer(s) demonstrate 5 years of successful installations of similar systems.
- Require submittal of manufacturer's literature describing the system, and samples of proposed clay tile.
- Require a pre-installation conference, scheduled after the substrates are complete, and including the Contractor, Architect, Owner, materials manufacturer, and installing subcontractor(s).
- Clay tile roofing is a finish material, not a staging platform for further construction work. Include the following provisions:
 - Require the Contractor to install a "temporary roof" if he desires to "dry-in" the building to allow interior construction to begin or to provide a platform for further exterior construction
 - Describe this requirement as a "Contractor's Option", that is, if he wants to dry-in, he must do so only with a temporary roof
 - Reference the National Roofing Contractor's Association (NRCA) requirements for temporary roofs, including "sacrificial" insulation on metal decks
 - Specifically prohibit "phased roofing"
 - Specifically prohibit all traffic from the finished roof
- Specify expanded warranties as follows:
 - 5 year warranty from the installer covering defects in installation
 - 10 year warranty from the materials manufacturer including defects in materials and installation, and guaranteeing to maintain the system in a waterproof condition for the life of the warranty
 - Renewal option for an additional 10 years from the materials manufacturer
 - Full replacement value without proration
 - Include all components of the roof assembly, from the deck up

- Include sealing of all perimeters, joints, and penetrations
- Both furnished on the University's special warranty form

Part 2 - Products

- Require that all primary and secondary materials be supplied by a single manufacturer, or approved by the primary materials manufacturer, to ensure single-point responsibility for the installation and warranty.
- Specify a manufacturer's standard clay tile roofing system as follows:
 - UL Class A fire rating
 - UL Class 90 wind uplift rating
 - Minimum 30-lb asphalt saturated underlayment
 - Barrel or tapered clay mission tile, closely approximating the existing University context in both color and form.
- Limit roof insulation to 2" thick. Specify insulations which provide adequate load-bearing capacity at the 2" thickness.

Part 3 - Execution

- Specifically require the roof to be installed in accordance with the manufacturer's recommendations.
- Specify only galvanized wire-tied tile installation.
- Refer to and describe the appropriate SMCNA details for each edge and penetration condition.
- Require the roofing installer to receive, accept, and install, all sheet metal flashings.
- Specifically prohibit:
 - Pitch pans
 - Guy wires fastened directly to the deck
- Specify (or detail) 3/4" plywood nailers at all parapet walls.
- Require a spray test after completion of the roofing system, to be witnessed by the Contractor, Architect, Owner, materials manufacturer, and installing contractor(s).

End of Section 07320

DIVISION 7 - THERMAL AND MOISTURE PROTECTION

Section 07410 - Preformed Roof and Wall Panels

Introduction

Systems described in this Section are intended to be installed in situations where the roof slope is at least 2-1/2 inches per foot, and where the roofs are not intended to receive regular foot traffic for equipment maintenance.

Specify a complete roofing system, making the materials manufacturer responsible for the roofing and flashing system. Require the materials manufacturer to make periodic inspections of the work in progress to ensure that the completed work will qualify for the required warranties.

Do not use roof deck insulation as the only element in the overall building thermal resistance system. Refer to Section 07200.

This is a section where the consultant should use a "performance specification". Do not specify proprietary manufacturer's names or materials, and do not restrict vendors to a limited list.

Metal roof repairs and modifications which are part of a renovation project (e.g. installation of a new exhaust fan) should follow these standards as much as possible. Existing roof warranties must not be compromised. The consultant must prepare a complete specification and details for the required repair work. Generic "flashing as required" notes (which often appear on engineering details for new exhaust fans) are not acceptable.

Be sure to coordinate specification requirements with roofing, flashing, and parapet wall details.

Part 1 - General

- Require that materials manufacturer(s) and installer(s) demonstrate 5 years of successful installations of similar systems.
- Require submittal of:
 - Manufacturer's literature describing the system
 - Shop drawings showing panel layout, and all edge, transition, and penetration details
 - Samples of proposed metal panels
- Require a pre-installation conference, scheduled after the substrates are complete, and including the Contractor, Architect, Owner, materials manufacturer, and installing subcontractor(s).
- Metal roofing is a finish material, not a staging platform for further construction work. Include the following provisions:
 - Require the Contractor to install a "temporary roof" if he desires to "dry-in" the building to allow interior construction to begin or to provide a platform for further exterior construction
 - Describe this requirement as a "Contractor's Option", that is, if he wants to dry-in, he must do so only with a temporary roof
 - Reference the National Roofing Contractor's Association (NRCA) requirements for temporary roofs, including "sacrificial" insulation on metal decks
 - Specifically prohibit "phased roofing"
 - Specifically prohibit all traffic from the finished roof
- Specify expanded warranties as follows:
 - 5 year warranty from the installer covering defects in installation
 - 30 year warranty from the materials manufacturer including defects in materials and installation, and guaranteeing to maintain the system in a waterproof condition for the life of the warranty

- Full replacement value without proration
- Include all components of the roof assembly, from the deck up
- Include sealing of all perimeters, joints, and penetrations
- Both furnished on the University's special warranty form

Part 2 - Products

- Require that all primary and secondary materials be supplied by a single manufacturer, or approved by the primary materials manufacturer, to ensure single-point responsibility for the installation and warranty.
- Specify a manufacturer's standard preformed metal roofing system as follows:
 - UL Class A fire rating
 - UL Class 90 wind uplift rating
 - Minimum 15-lb asphalt saturated underlayment
 - Factory formed panels, steel, aluminum, or copper
 - Concealed fastener installation
 - Factory applied polyvinylidene fluoride finish, or natural metal finish intended for exposure to the elements
- Limit roof insulation to 2" thick. Specify insulations which provide adequate load-bearing capacity at the 2" thickness.
- Minimum gauges
 - Roofs 22 ga
 - Walls 18 ga
- Minimum panel width 12"

Part 3 - Execution

- Specifically require the roof to be installed in accordance with the manufacturer's recommendations.
- Refer to and describe the appropriate SMCNA details for each edge and penetration condition.
- Require the roofing installer to receive, accept, and install, all sheet metal flashings.
- Specifically prohibit:
 - Pitch pans
 - Guy wires fastened directly to the deck
- Specify (or detail) 3/4" plywood nailers at all parapet walls.
- Require a spray test after completion of the roofing system, to be witnessed by the Contractor, Architect, Owner, materials manufacturer, and installing contractor(s).

End of Section 07410

DIVISION 7 - THERMAL AND MOISTURE PROTECTION

Section 07500 - Membrane Roofing

Introduction

Systems described under this Section are not intended to receive regular foot traffic. Occasional traffic for maintenance of equipment is acceptable.

Where horizontal surfaces enclosing habited spaces are intended to be regularly occupied or otherwise used for the building occupants' activities, refer to the requirements of Section 07590 Horizontal Traffic Surfacing.

Specify a complete roofing system, making the materials manufacturer responsible for the roofing and flashing system. Require the materials manufacturer to make periodic inspections of the work in progress to ensure that the completed work will qualify for the required warranties.

The University uses a built-up SBS-modified bitumen roofing system, applied either hot mopped, self adhered or cold emulsion, in virtually all conditions. Use of other roofing systems must receive specific permission from the Project Manager.

Gravel surface roofs shall NOT be specified.

Torch-applied materials of any kind shall NOT be specified.

Single-ply roofs shall NOT be specified.

Asbestos-containing materials shall NOT be specified.

This is a section where the consultant should use a "performance specification". Do not specify proprietary manufacturer's names or materials, and do not restrict vendors to a limited list.

Membrane roof repairs and modifications which are part of a renovation project (e.g. installation of a new exhaust fan) should follow these standards as much as possible. Existing roof warranties must not be compromised. The consultant must prepare a complete specification and details for the required repair work. Generic "flashing as required" notes (which often appear on engineering details for new exhaust fans) are not acceptable.

Be sure to coordinate specification requirements with roofing, flashing, and parapet wall details.

Part 1 - General

- Require that materials manufacturer(s) and installer(s) demonstrate 5 years of successful installations of similar systems.
- Require submittal of manufacturer's literature describing the system, and samples of proposed membrane materials.
- Require a pre-installation conference, scheduled after the substrates are complete, and including the Contractor, Architect, Owner, materials manufacturer, and installing subcontractor(s).
- Membrane roofing is a finish material, not a staging platform for further construction work. Include the following provisions:
 - Require the Contractor to install a "temporary roof" if he desires to "dry-in" the building to allow interior construction to begin or to provide a platform for further exterior construction.
 - Describe this requirement as a "Contractor's Option", that is, if he wants to dry-in, he must do so only with a temporary roof.
 - Reference the National Roofing Contractor's Association (NRCA) requirements for temporary roofs, including "sacrificial" insulation on metal decks.
 - Specifically prohibit "phased roofing".
 - Specifically prohibit patches in the finished roof.
 - Require that finished roofs be protected with plywood sheets for any and all construction traffic, and that all equipment moving be accomplished with rollers.

- Specify expanded warranties as follows:
 - 5 year warranty from the installer covering defects in installation.
 - 20 year warranty from the materials manufacturer including defects in materials and installation, and guaranteeing to maintain the system in a waterproof condition for the life of the warranty.
 - Full replacement value without proration.
 - Include all components of the roof assembly, from the deck up.
 - Include sealing of all perimeters, joints, and penetrations.
 - Both warranties shall be furnished on the University's special warranty form. Any reference to maximum wind speed on the warranty shall not supersede the requirement to provide a UL Class 90 uplift rating.
- Calculate insulation thickness to allow for 8" minimum clearance for all roof penetrations, doors, curbs, windows, etc.

Part 2 - Products

- Require that all primary and secondary materials be supplied by a single manufacturer, or approved by the primary materials manufacturer, to ensure single-point responsibility for the installation and warranty.
- Specify a manufacturer's standard built-up roofing system as follows:
 - UL Class A fire rating.
 - UL Class 90 uplift rating.
 - Rigid overlayment or cover board on top of insulation to increase roof durability and hail resistance.
 - 2-ply SBS-modified bitumen system. (Base sheet + mineral surface cap sheet)
 - Reflective roof coating to meet project Solar Reflectance Index. Apply after all work is complete and roof is accepted.
 - Applied with either hot asphalt mop, self-adhered or cold emulsion.
- Care should be taken in the selection of tapered rooftop insulation and rigid overlayment board to insure a durable roof surface that will hold up to maintenance activities for the life of the roof and will not compress over time under various loads. Lightweight insulating concrete can also be considered if project conditions and budget dictate.

Part 3 - Execution

- Specifically require the roof to be installed in accordance with the manufacturer's recommendations.
- Refer to and describe the appropriate SMCNA details for each edge and penetration condition. Require the roofing installer to receive, accept, and install, all sheet metal flashings.
- Specifically prohibit:
 - Pitch pans.
 - Guy wires fastened directly to the deck.
- Specify (or detail) 3/4" plywood nailers at all parapet walls.
- Require a spray test after completion of the roofing system, to be witnessed by the Contractor, Architect, Owner, materials manufacturer, and installing contractor(s). Do not require a flood test.

End of Section 07500

DIVISION 7 - THERMAL AND MOISTURE PROTECTION

Section 07570 - Traffic Topping

Introduction

Systems described under this Section are intended to be installed on exterior walking surfaces which do not enclose habited space.

Where horizontal surfaces enclosing habited spaces are intended to be regularly occupied or otherwise used for the building occupants' activities, refer to the requirements of Section 07590 Horizontal Traffic Surfacing.

Specify a complete traffic topping system, making the materials manufacturer responsible for the roofing and flashing system. Require the materials manufacturer to make periodic inspections of the work in progress to ensure that the completed work will qualify for the required warranties.

This is a section where the consultant should use a "performance specification". Do not specify proprietary manufacturer's names or materials, and do not restrict vendors to a limited list.

Traffic topping repairs and modifications which are part of a renovation project should follow these standards as much as possible. Existing warranties must not be compromised. The consultant must prepare a complete specification and details for the required repair work. Generic "flashing as required" notes are not acceptable.

Be sure to coordinate specification requirements with traffic topping, flashing, and parapet wall details.

Part 1 - General

- Require that materials manufacturer(s) and installer(s) demonstrate 5 years of successful installations of similar systems.
- Require submittal of manufacturer's literature describing the system, and samples of proposed membrane materials.
- Require a pre-installation conference, scheduled after the substrates are complete, and including the Contractor, Architect, Owner, materials manufacturer, and installing subcontractor(s).
- Traffic topping is a finish material, not a staging platform for further construction work. Include the following provisions:
 - Specifically prohibit "phased installation" of traffic topping
 - Specifically prohibit patches in the finished membrane
 - Require that finished decks be protected with plywood sheets for any and all construction traffic, and that all equipment moving be accomplished with rollers
- Specify expanded warranties as follows:
 - 5 year warranty from the installer covering defects in installation
 - 10 year warranty from the materials manufacturer including defects in materials and installation, and guaranteeing to maintain the system in a waterproof condition for the life of the warranty
 - Renewal option for an additional 10 years from the materials manufacturer
 - Full replacement value without proration
 - Include all components of the traffic topping assembly, from the deck up
 - Include sealing of all perimeters, joints, and penetrations
 - Both furnished on the University's special warranty form

Part 2 - Products

- Expressly prohibit the use of asbestos-containing materials.
- Require that all primary and secondary materials be supplied by a single manufacturer, or approved by the primary materials manufacturer, to ensure single-point responsibility for the installation and warranty.
- Specify a manufacturer's standard traffic topping system as follows:
 - UL Class A fire rating
 - Manufacturer's proprietary primer
 - Fully-adhered, fabric-reinforced, rubberized urethane waterproof membrane
 - Elastomeric polyurethane wear surface, with integral color and slip-resistant finish
 - Minimum system thickness 225 mils
 - Integral cove flashing

Part 3 - Execution

- Specifically require the traffic topping to be installed in accordance with the manufacturer's recommendations.
- Refer to and describe the appropriate SMCNA details for each edge and penetration condition.
- Require the traffic topping installer to receive, accept, and install, all sheet metal flashings.
- Specifically prohibit:
 - Pitch pans
 - Guy wires fastened directly to the deck
- Specify (or detail) 3/4" plywood nailers at all parapet walls.
- Require a spray test after completion of the roofing system, to be witnessed by the Contractor, Architect, Owner, materials manufacturer, and installing contractor(s).

End of Section 07570

DIVISION 7 - THERMAL AND MOISTURE PROTECTION

Section 07590 - Horizontal Traffic Surfacing

Introduction

Systems described under this Section are intended to be installed on exterior walking surfaces which enclose habited space.

Where horizontal surfaces which do not enclose habited spaces are intended to be regularly occupied or otherwise used for the building occupants' activities, refer to the requirements of Section 07570 Traffic Topping.

Specify a complete horizontal traffic surfacing system, making the materials manufacturer responsible for the surfacing and flashing system. Require the materials manufacturer to make periodic inspections of the work in progress to ensure that the completed work will qualify for the required warranties.

Do not use traffic deck insulation as the only element in the overall building thermal resistance system. Refer to Section 07200.

This is a section where the consultant should use a "performance specification". Do not specify proprietary manufacturer's names or materials, and do not restrict vendors to a limited list.

Horizontal traffic surfacing repairs and modifications which are part of a renovation project should follow these standards as much as possible. Existing warranties must not be compromised. The consultant must prepare a complete specification and details for the required repair work. Generic "flashing as required" notes are not acceptable.

Be sure to coordinate specification requirements with traffic surfacing, flashing, and wall details.

Part 1 - General

- Require that materials manufacturer(s) and installer(s) demonstrate 5 years of successful installations of similar systems.
- Require submittal of:
 - Manufacturer's literature describing the system
 - Samples of proposed membrane materials
 - Samples of the proposed pavers
- Require a pre-installation conference, scheduled after the substrates are complete, and including the Contractor, Architect, Owner, materials manufacturer, and installing subcontractor(s).
- Horizontal traffic surfacing is a finish material, not a staging platform for further construction work. Include the following provisions:
 - Require the Contractor to install a "temporary roof" if he desires to "dry-in" the building to allow interior construction to begin or to provide a platform for further exterior construction
 - Describe this requirement as a "Contractor's Option", that is, if he wants to dry-in, he must do so only with a temporary roof
 - Reference the National Roofing Contractor's Association (NRCA) requirements for temporary roofs, including "sacrificial" insulation on metal decks
 - Specifically prohibit "phased" traffic surfacing installation
 - Specifically prohibit patches in the finished membrane
 - Require that finished systems be protected with plywood sheets for any and all construction traffic, and

that all equipment moving be accomplished with rollers

- Specify expanded warranties as follows:
 - 5 year warranty from the installer covering defects in installation
 - 10 year warranty from the materials manufacturer including defects in materials and installation, and guaranteeing to maintain the system in a waterproof condition for the life of the warranty
 - Renewal option for an additional 10 years from the materials manufacturer
 - Full replacement value without proration
 - Include all components of the traffic surfacing assembly, from the deck up, including removal and reinstallation of the pavers
 - Include sealing of all perimeters, joints, and penetrations
 - Both furnished on the University's special warranty form

Part 2 - Products

- Expressly prohibit the use of asbestos-containing materials.
- Require that all primary and secondary materials be supplied by a single manufacturer, or approved by the primary materials manufacturer, to ensure single-point responsibility for the installation and warranty.
- Specify a manufacturer's standard horizontal traffic surfacing system as follows:
 - UL Class A fire rating
 - Fabric-reinforced fully-adhered, rubberized asphalt membrane, 225 mils minimum thickness
 - Integral cove flashing
 - Manufacturer's proprietary protection sheet
 - Manufacturer's proprietary drainage sheet
 - 1" thick, cfc-free, extruded polystyrene foam insulation, approved by horizontal traffic surfacing system manufacturer
 - Precast concrete pavers
 - *Special attention shall be given so as to ensure that concrete pavers provide appropriate slip resistance. Stained, coated or painted pavers are expressly prohibited.*

Part 3 - Execution

- Specifically require the horizontal traffic surfacing to be installed in accordance with the manufacturer's recommendations.
- Refer to and describe the appropriate SMCNA details for each edge and penetration conditions.
- Require the traffic surfacing installer to receive, accept, and install, all sheet metal flashings.
- Specifically prohibit:
 - Pitch pans
 - Guy wires fastened directly to the deck
- Specify (or detail) 3/4" plywood nailers at all parapet walls.
- Require a spray test after completion of the roofing system, to be witnessed by the Contractor, Architect, Owner, materials manufacturer, and installing contractor(s).

End of Section 07570

DIVISION 7 - THERMAL AND MOISTURE PROTECTION

Section 07600 - Flashing and Sheet Metal

Introduction

Wherever possible, describe flashing systems which use concealed fasteners, clips, and cleats. Where exposed fasteners are unavoidable, specifically describe a fastening system which absolutely prohibits entrance of water, and which will remain watertight for the life of the facility.

Wherever possible, avoid reliance on sealants as the sole means of prohibiting entrance of water.

Use matching materials on renovations of existing buildings which contain copper flashing materials.

Describe all requirements for installation of sheet metal work which is associated with the roofing system and its special warranties in the appropriate roofing section, to maintain single-point responsibility for the roof warranty.

Describe all requirements for sealants in Section 07900.

Specifically detail all conditions on the drawings, including references to specific requirements of the Sheet Metal and Air Conditioning Contractor's National Association (SMACNA) "Architectural Sheet Metal Manual".

Part 1 - General

- Require submittal of shop drawings and details of each condition and joint.

Part 2 - Products

- Specify minimum 24 gauge thickness for galvanized metal, and identify specific heavier gauges where the project requires.
-OR-
- Specify minimum 16 ounce for copper, and identify specific heavier materials where the project requires.
- Use only minimum 16 ounce copper for masonry through-wall, lintel, or other similar embedded flashings.
- Use only 4 pound lead for roof drain sump pans.
- When necessary, use 4 pound lead for flashings involving compound curves or where sheetmetal can not be adequately formed. This application requires a galvanized sheet metal protective cover.
- Where 2-piece reglets are required, describe the specific shape and substrate conditions, but do not reference proprietary manufacturer's products.
- Do not specify roof jacks or boots which utilize integral neoprene seals.
- Use only galvanized structural steel tube or pipe for downspout sections which are subject to impact and abuse.
- Specify only 50/50 tin/lead solder when applicable.
- Specify only non-corrosive fasteners, same material as metal being fastened, with matching finish on exposed heads. Specify neoprene-backed washers for screw fasteners.

- **Part 3 - Execution**

- Specifically describe requirements for expansion and contraction joints, and for sealing joints in running flashings. Do not rely on generic "provide expansion joints as required" notes.
- Specifically design joints to allow for removal and reinstallation of flashings during re-roofing. Two-piece reglets are preferred.
- Specifically describe requirements for separating dissimilar metals.

End of Section 07600

DIVISION 7 - THERMAL AND MOISTURE PROTECTION

Section 07700 - Roof Specialties and Accessories

Introduction

Include all items which become an integral part of the roof moisture protection system in this Section.

In certain limited situations where items are more appropriately described in other sections (e.g. prefabricated mechanical equipment curbs), make specific cross references in both sections, and require the installation of those items to comply with the requirements of the appropriate Division 7 Section(s).

Describe all requirements for installation of roof accessories which are associated with the roofing system and its special warranties in the appropriate roofing section, to maintain single-point responsibility for the roof warranty.

Accessories which require structural support (e.g. antennae) must be supported from the building structure. Do not specify and expressly prohibit attachments through the roof membrane, and guy wires.

Items which must pass through the roof membrane (e.g. antennae cables) must pass through a conduit. Do not specify and expressly prohibit penetrations directly through the membrane, and cables snaked through other penetrations.

Detail and specify burglar bars (6" maximum spacing each way) in all situations where roof deck openings would otherwise allow entry to the building.

Part 1 - General

- Require submittal of manufacturer's literature, and installation details.

Part 2 - Products

- Specify only metal accessories. Specifically prohibit use of PVC and other plastics.
- Wherever possible, specify accessories which have integral curbs sufficiently tall to permit secure installation of flashing and counterflashing.
- Where roof accessories are not ordinarily curbed, specify and detail custom fabricated curbs.
- Avoid as much as possible accessory units which rely on flat flanges to permit secure application of roof membrane.

Part 3 - Execution

- There are no unique University requirements in this Section.

End of Section 07700

DIVISION 7 - THERMAL AND MOISTURE PROTECTION

Section 07800 - Skylights

Introduction

Avoid use of skylights wherever possible. Clerestories and light monitors are superior solutions. Use skylights, clerestories, and monitors only with specific permission of the Project Manager.

Existing skylights which are part of a renovation project should always be considered for removal or replacement with alternative light gathering elements. Specifically discuss such situations with the Project Manager.

Describe all requirements for flashing and sealing of skylights in the appropriate roofing section, to maintain single-point responsibility for the roof warranty.

Skylights which require structural support must be supported from the building structure. Do not specify and expressly prohibit attachments through the roof membrane.

Detail and specify burglar bars (6" maximum spacing each way) in all situations where roof deck openings would otherwise allow entry to the building.

Part 1 - General

- Require submittal of manufacturer's literature, and installation details.

Part 2 - Products

- Specify only double-domed, solar-glazed, steel or aluminum-framed skylights.
- Wherever possible, specify skylights which have integral curbs sufficiently tall to permit secure installation of flashing and counterflashing.
- Where the required skylight roof is not integrally curbed, specify and detail custom fabricated curbs.
- Do not use skylights which rely on flat flanges to permit secure application of roof membrane.

Part 3 - Execution

- There are no unique University requirements in this Section.

End of Section 07800

DIVISION 7 -THERMAL AND MOISTURE PROTECTION

Section 07900 - Sealants

Introduction

Describe all requirements for installation of sealants required to prohibit the penetration of moisture and dust, and required to seal joints between dissimilar materials, in this Section.

Specify certain specialized sealants which are ordinarily part of a "complete in place" installation by a particular trade (e.g. glazing sealants and painting) in the appropriate sections.

Reliance on caulking which might (or might not) be provided by a painter as part of that finish operation, as the moisture- or dust-seal, is unacceptable.

Pay particular attention in sealant system design to expected joint movement, joint dimensions, sealant position (horizontal, vertical, or overhanging), and potential for physical abuse of the sealed joint.

Specifically describe and detail on the drawings all joints requiring installation of sealants. Generic notes such as "sealant as required" are not acceptable.

This is a section where the Consultant should use a "performance specification". Do not specify proprietary manufacturer's names or materials, and do not restrict vendors to a limited list.

Part 1 - General

- Require that all materials manufacturer(s) and installer(s) demonstrate 5 years of successful installations of similar materials.
- Require submittal of the following:
 - Manufacturer's literature documenting compliance with specification requirements
 - Actual sealant samples for color selection
 - Sample joints, where unique conditions require
- Maximum allowable exterior joint width, for caulking/sealant, shall not exceed 1".

Part 2 - Products

- Specify each particular type of sealant and sealant system required, including:
 - Primers
 - Backers
 - Fillers
 - Colors
- Expressly prohibit the use of latex and butyl sealants.
- Specify only non-staining materials.

Part 3 - Execution

- Provide a sealant schedule identifying location and type of sealant.
- Specifically require sealants to be installed in accordance with the manufacturer's recommendations.
- Specifically require all joints to be observed by the Owner prior to installation of sealants.

End of Section 07900

DIVISION 8 - DOORS AND WINDOWS

Section 08000 - General Discussion

Introduction

This General Discussion Section contains material which is critical to successful door and window installations, in new construction and renovation, but which is not the sole responsibility of any individual trade. In many cases, the issues involved are fundamental to the basic design of the project, and the success or failure of this element of the project is determined at the very outset of the design process.

The Consultant is expressly responsible for incorporating these overall requirements into the project, and for ensuring that all subconsultants are aware of the requirements and incorporate them into their designs as well.

Reliance on "after-the-fact" material selections to compensate for a problematic design decision is unacceptable.

The use of wired fire rated safety glass has been determined an undesirable safety risk and is no longer allowed. Consequently glazed openings in fire rated doors and windows will require the use of fire rated glass.

Major Entrances

Generally, major building entrances will utilize some sort of monumental storefront system. All other exterior doors and frames should be steel.

Multiple Doors, Pairs of Doors, Banks of Doors

Exit widths in excess of 3'-0" are often required in major facilities. In such instances, the University prefers to use banks of single leaf doors, rather than double doors with center mullions. This requirement includes the following situations:

- major building entrances
- assembly occupancy entrance/exits (both interior and exterior)

In such situations which also require large widths for passage of equipment, use wider door leaves.

Preferably, use overhead doors as the primary means for passage of equipment.

Since the University does not use vertical rod exit devices, pairs of doors will necessarily have center mullions. In situations where use of center mullions is unavoidable and which also require large widths, the mullions must be removable. Specify these mullions in Section 08710 - Hardware.

Do not specify center mullions for double-egress doors in corridors.

Large Interior Doors

Where interior spaces require large doors for the passage of equipment (e.g. general laboratories, shared equipment laboratories, etc.), specify 3'-6" or 4'-0" single leaf doors (with appropriate adjustments in frame gauge and hardware requirements) rather than pairs of 3'-0" + 1'-0" doors.

Coordination and Preparation

Make specific references to ensure that requirements for coordination of doors, frames, and hardware, is clearly included in the Contractor's scope of work. This often involves the steel door and frame supplier, the wood door supplier, the hardware supplier, and the installers of these materials. While this type of coordination is implicit in the Contractor's scope, a specific reference provides an additional level of comfort.

A common example of the lack of this coordination is an interior wood door in a steel frame with a smoke gasket. If even one of the trades involved fails to properly coordinate, it is likely the door will not close and latch properly against the gasket.

The Consultant should also ensure during submittal review that such issues are clearly identified in the submittals of all the trades involved.

End of Section 08000

DIVISION 8 - DOORS AND WINDOWS

Section 08110 - Steel Doors and Frames

Introduction

This is a section where the consultant should use a "performance specification". Do not specify proprietary manufacturer's names or materials, and do not restrict vendors to a limited list.

Do not specify knock-down or so-called "drywall" metal door frames.

Part 1 - General

- Require that all steel doors and frames comply with the requirements of:
 - National Association of Architectural Metal Manufacturers Standard HMMA 861
 - Building Hardware Manufacturer's Association (BHMA)
 - Underwriter's Laboratories (UL) rated and labeled where required
- Require submittal of:
 - manufacturer's literature
 - shop drawings
 - Complete door and frame schedule covering every opening

Part 2 - Products

- Specify doors and frames in the following gauges:
 - exterior frames: 14 gauge
 - interior frames > 4'-0": 14 gauge
 - interior frames < 4'-0": 16 gauge
 - doors: 18 gauge
- Specify doors and frames with factory-applied primer, ready for field finishing.
- Specify and detail door frames with:
 - fully mitered, welded, and ground corners
 - double rabbeted profiles, with equal-sized rabbets
 - 2" rails and head, and always equal-size
 - exterior sidelights and transoms for interior glazing only
 - lights which extend to the floor with 4" bottom rails
 - mortar boxes for all hardware
 - ASA strikes for full mortise locks
 - 4 wall anchors plus 2 drilled floor anchors per jamb
 - corrugated 14 gauge T-type for masonry walls
 - welded to frame for stud walls
 - weld jamb clips at metal stud walls to door frame
 - use dimpled anchors only for openings in existing walls.
- silencers on all frames

- Specify and detail doors with:
 - seamless faces
 - edge seams welded and ground
 - rigid polystyrene core fully bonded to the steel face sheets
 - closed watertight top
 - inverted bottom closure channel
 - minimum 6" head rail, 6" stiles, and 12" bottom rail, at all lights and louvers
 - provide pockets for full mortise lock
- Specifically require that doors and frames be prepared and internally reinforced at the factory for installation of butts, closers, locksets, exit devices, and all other scheduled hardware. Specifically prohibit field preparation of steel doors and frames.
- Make specific reference that the rabbet of door frames be sized, and that factory preparation for butts in both doors and frames must make allowance, for silencers or smoke gaskets.

Part 3 - Execution

- Specifically require that all doors and frames be installed in conformance with HMMA, BHMA, and UL requirements.
- Require that all doors be completely hung, with all hardware installed, tested, and adjusted for perfect fit, prior to field finishing. Require that doors be dismantled and hardware removed, and re-hung after finishing is complete.

End of Section 08110

DIVISION 8 - DOORS AND WINDOWS

Section 08210 - Wood Doors

Introduction

This is a section where the consultant should use a "performance specification". Do not specify doors by proprietary manufacturer's names or model numbers, and do not restrict vendors to a limited list.

Do not specify wood doors for exterior applications.

Part 1 - General

- Reference the following standards as applicable and coordinate specifications to comply without conflicts.
 - Architectural Woodwork Institute (AWI) Quality Standards, Section 1300 Architectural Flush Doors, current edition.
 - Window & Door Manufacturers Association (WDMA), ANSI/WDMA I.S 1-A-97 Wood Flush Doors
 - NFPA 80 – Fire Doors and Windows
 - NFPA 252 – Fire Test for Door Assemblies
 - ASTM E152 – Fire Tests of Door Assemblies
 - UL 10B – Fire Tests of Door Assemblies
- Require these associations' stamps and labels to be affixed to the doors.
- Require submittal of manufacturer's literature, and 6"x6" corner samples.
- Require doors to be wrapped in plastic. Individual cartoning is not required.
- Specify full lifetime guarantee for interior wood doors. Include defective materials and fabrication, delamination, warping, telegraphing. Include replacement, reinstallation, and refinishing of the door.

Part 2 - Products

- Specify only 1-3/4" thick solid core doors for all interior applications.
- Specify doors complying with AWI "premium grade", PC7 ME or PC5 ME with select white birch veneer faces, rotary cut, book matched grain, balance matched assembly, for transparent finish. For new buildings, alternative veneers require project manager approval.
- Specify particle board cores, with stiles and rails glued to core and sanded before laminating, for general non-rated applications, and for 20-minute fire-rated applications.
- Specify mineral cores of appropriate ratings, with stiles and rails glued to core and sanded before laminating, where 3/4-hour or longer fire-rated doors are required.
- Require solid wood blocks in fire-rated doors as support for installation of mortise and/or cylinder type locksets (2-3/4" backset), and of closers.
- Require rails and stiles of solid hardwood (not laminated or veneered), 1-1/8" minimum for rails, 1-3/8" minimum for stiles.
- Require surrounds for lite and louver openings for non-rated doors of solid hardwood (not laminated or veneered), 6" minimum.
- Specify glazing stops of same hardwood as door facing.

- Require rated metal surrounds and glazing for lites at rated doors. Require profile of rated surround to match profile of specified wood surrounds of non-rated doors.
- Specify pair matched, set matched and continuous matched transoms, where applicable.
- Specify only Type I adhesives for all applications.
- Specify minimum STC 35 sound rating for single leaf doors for most applications. Discuss requirements for higher STC ratings with the Project Manager.

Part 3 - Execution

- Specify installation using the following criteria:
 - bevel doors on 3 sides.
 - trim doors to provide 1/8" reveal on 3 sides.
 - if beveling or trimming is required, seal all surfaces to prevent swelling.
 - machine, trim, and mount doors to receive all specified items of hardware (especially smoke gaskets and weatherstrips), and to latch without binding.

End of Section 08210

DIVISION 8 - DOORS AND WINDOWS

Section 08305 - Access Doors

Introduction

Provide access doors to attics, roofs, crawl spaces, tunnels, elevator equipment rooms, overhead areas, mechanical equipment rooms, and similar spaces where University personnel must have access for maintenance or repair.

All access doors shall be specified in this section. Coordinate with work in other divisions (i.e., electrical and mechanical). On architectural drawings show all access doors on ceiling plans and on wall elevations.

Part 1 - General

- Minimum size shall be 16" x 16" for walls and 24" x 24" for ceilings. Size may be larger if required for replacement of materials/equipment.
- Access doors shall be fire rated where required. Locations should be noted on plans.
- All access doors shall be metal.
- Provide key locks only on doors to elevator equipment areas

Part 2 - Products

- Access doors shall have continuous hinges and a minimum of two (2) cam type latches..

Part 3 - Execution

- Access doors shall be painted in the open position.

End of Section 08305

DIVISION 8 - DOORS AND WINDOWS

Section 08330 - Overhead Coiling Doors

Introduction

Provide Overhead coiling doors where necessary for service or access. Avoid the use of pairs of swing type doors for service access

Avoid these type doors as part of fire rated wall opening

Avoid the use of security grilles

Where egress is required, provide adjacent (not integral) personnel exit door assembly.

Where an insulated door is required, sectional type shall be provided.

Part 1 - General

- Use manual push up type except where crank, chain or motor operation is appropriate due to size.

Part 2 - Products

- Provide cylinder locking method in bottom bars.

Part 3 - Execution

- Insure that fusible link, if applicable, is accessible on doors used as a fire rated curtain.

End of Section 08330

DIVISION 8 - DOORS AND WINDOWS

Section 08400 - Entrances and Storefronts

Introduction

Evaluate if future reglazing can be accomplished easily from the exterior.

Part 1 - General

- Consultant shall establish the minimum level of quality. System shall be “engineered”.
- Generally, these systems shall not incorporate operable windows.
- System shall accommodate the hardware components specified in Section 08710 - Finish Hardware. Substitutions of manufacturers standard hardware is not permitted.

Part 2 - Products

- Finishes shall be noted. If anodized or powder coated give class #.
- Determine if window washing hooks are necessary.
- Require design to provide for a simple re-glazing system.
- Specify the framing system. System shall provide positive drainage to the exterior.
- Entrance doors shall be minimum “wide style” type. Equivalent to Kawneer 500 series or approved equal.

Part 3 - Execution

- There are no unique University requirements.

End of Section 08400

DIVISION 8 - DOORS AND WINDOWS

Section 08500 - Metal Windows

Introduction

Finishes, maintenance and heat loss or gain are important considerations. Double glazing is required on all exterior windows.

Operable sash for emergency exit from dormitory rooms to meet code requirements must be considered as well as operable sash in air conditioned buildings where the equipment may fail for some reason.

Institutional quality construction and superior coatings and finishes should be considered if the budget will permit.

Interior glazing is preferred, for glass replacement, above the ground floor level.

Part 1 - General

- Require test results for water and air infiltration.
- Require certification that window meets requirements of Steel Window Institute or Aluminum Window Institute.
- Detailing shall provide for drainage, weepage, flashing, etc. for a weather tight installation.

• **Part 2 - Products**

- Require protective coverings if materials are prefinished.

• **Part 3 - Execution**

- There are no unique University requirements.

End of Section 08500

DIVISION 8 - DOORS AND WINDOWS

Section 08610 - Wood Windows

Introduction

Wood windows are to be used only in restoration work on historical buildings.

Part 1 - General

- There are no unique University requirements.

- **Part 2 - Products**

- There are no unique University requirements.

- **Part 3 - Execution**

- There are no unique University requirements.

End of Section 08610

DIVISION 8 - DOORS AND WINDOWS

Section 08710 - Finish Hardware

Introduction

The University of Arizona has determined that, based on its experience with the performance and durability of the products described in this Section, and based on the benefits of limiting the range of repair parts which must be maintained in inventory, a proprietary specification is in the best interest of the University.

Specify all hardware required for a fully functioning, secure, weatherproof installation for all swinging, sliding, and folding doors.

Include unique door or frame dependent hardware in those sections.

Include cabinet hardware in the appropriate Division 6 section.

Comply with prevailing codes, standards and accessibility standards for project location.

In renovation projects, specify hardware which matches the existing hardware type for function, appearance, trim, and finish, except where other overriding considerations such as handicapped accessibility require deviations.

The Consultant must determine the existing conditions and specify materials which match those conditions.

Requiring the Contractor to "match existing as required" is unacceptable.

In special cases, hardware different from those items described below may be required. In all such cases, secure specific permission of the Project Coordinator. These cases may include:

Alarmed exit devices

Electronic security access

Matching "period" hardware in historic buildings

Include on the drawings a schedule indicating which specific hardware group applies to each individual door. Pay particular attention to identifying the desired function of each door lockset.

Finish Hardware Specifications shall be written by a certified Architectural Hardware Consultant familiar with the requirements of the University of Arizona. A local consultant and manufacturer's representative that has rendered assistance with the UA DSS Manual that could be available to assist, is listed below:

John Hamilton, AHC/EHC, CPP
Allegion, PLC
Phone 480-377-6702 Cell 602-309-5918
john.hamilton@allegion.com

Part 1 - General

- Require submittal of a complete hardware schedule, submitted in a DHI Vertical Format, describing each door and each hardware group, including technical data for each item.
- Require that the supplier of finish hardware have as a full-time employee a regular member of the Door & Hardware Institute (DHI), and that the hardware schedule be prepared by a certified Architectural Hardware Consultant (AHC).
- Require delivery to the UA FM Lock Shop upon Substantial Completion all adjusting tools, keys, dogging keys, and other maintenance materials (specific to pieces of hardware).
- All hardware to be installed with mounting hardware supplied by the hardware manufacturer.
- Hardware Supplier shall be a stocking dealer physically located in the United States of America.
 - Hardware supplier, UA FM Lock Shop and complete project team should participate in submittal phase coordination meetings as needed to complete coordination with all other trades (doors, frames, electrical) and vendors (Amer-X).

- Hardware supplier, UA FM Lock Shop and complete project team should participate in a pre-installation meeting prior to hardware installation and conduct a post installation review and adjustment of all hardware 3-6 months after occupancy.

Part 2 - Products

- Butts (Hinges);
 - Pre-qualified manufacturers are:
 - Hager
 - McKinney
 - Ives
 - Follow hinge manufacturer's recommendations for size, type, metal and quantity. Minimum 1-1/2 pair per door
 - Preference is for ball bearing five-knuckle hinges, with non-removable pins and a lifetime warranty for all openings. Same is a requirement for all openings with door closers.
 - Comply with NFPA-80 at rated openings.
- Locksets and Latches;
 - Pre-qualified manufacturer and lockset series is:
 - Schlage Lock, L Series, UNIVERSITY STANDARD
 - Locksets shall accept non-interchangeable core Medeco cylinders.
 - Permanent cylinders will be provided by UA FM Lock Shop.
 - All Schlage lock and latch sets shall be purchased through an authorized, stocking, Allegion Dealer physically located in the United States.
 - On building renovation and expansion projects verify with FM lock shop for manufacturer and type of locksets required
- Mortise;
 - Use L Series, labeled, mortise locks, less cylinders, at heavy duty applications such as those listed below. For additional information, see cylinder and keying section below.
 - As general rule the UNIVERSITY STANDARD is for full mortise locksets in all University buildings. Consult with UA FM Lock Shop for any exceptions. Mortise locksets are especially crucial in high use heavy duty applications such as laboratories, classrooms, stairwells, main entries, etc.
 - Use "06A" rose and lever for trim design selection
 - Use ND Series, non-interchangeable core, cylindrical locksets less cylinders for any general or low use applications subject to FM Lock Shop approval. Medeco Throw Members to be provided by the UA FM Lock Shop for their use installing permanent cylinders. For additional information, see cylinder and keying section below.
 - Use "Rhodes (RHO) and lever trim design selection.
 - Generally use the following functions in the noted applications. Use of other functions may be required by User and UA FM Lock Shop.
 - Passage Interior closets or non-locking doors
 - Schlage Mortise Function: L9010S 06A
 - Schlage Cylindrical Function:ND10S RHO
 - Privacy Single person toilet rooms.

- Storeroom
(Always Locked)
 - Schlage Mortise Function: L9040S 06 w/ occupancy indicator
 - Schlage Cylindrical Function: ND40S RHO
Restricted interior applications (animal quarters, bio-hazard labs, radio-hazard labs, etc.) and all interior and exterior service spaces (mechanical rooms, equipment rooms, telecomm rooms, always locked storage rooms, custodial closets, etc.) and ground level stairwell exit doors that do not require panics.
 - Schlage Mortise Function: L9080 L 06A
 - Schlage Electrical Mortise Function: L9092 LEU 06A (EL at fail safe applications) New construction to be 24 VDC. Verify with UA FM Lock Shop for existing voltage.
 - Schlage Cylindrical Function: ND80LD RHO
 - Schlage Electrical Cylindrical Function: ND80LD RHO DEU (DEL at fail safe applications) at access controlled doors. New construction to be 24VDC. Verify with UA FM Lock Shop for existing voltage.
- Office
 - All "assigned" interior applications (offices, laboratories, etc.)
 - Schlage Mortise Function: L9050L 06A
 - Schlage Cylindrical Function: ND53LD RHO
- Classroom (key)
 - All "shared" interior applications (classrooms, lecture halls, etc.)
 - Schlage Mortise Function: L9070L 06A
 - Schlage Cylindrical Function: ND70LD RHO (Classroom security function is not utilized)
- Auxiliary Deadlock
 - Corridor toilet rooms
 - Schlage Mortise Deadbolt: L463 classroom function at multiple user restrooms. Use with push/pulls.

- Vandalguard is not utilized.
- 2-3/4" backset typical. Exception: Where conflict may exist with sound or other seals conflicting with lock rose.
- Only 4-7/8" "ASA" type strikes with no filing or other modifications to make fit.
- Cylindrical latch throw to be 1/2" minimum or 3/4" or as required by opening fire label testing.
- Provide extended lip strikes where required to protect frame or trim. Lip shall not extend more than 1/8" beyond frame or door (at pairs) or trim.
- In renovation applications, comply with these requirements regardless of the style of existing locks and latches unless directed otherwise by Project Manager.
- Door hardware and handles shall comply with all applicable code and accessibility requirements for the project.
- Provide latch protectors at ALL exterior outswinging doors and at any interior locked, outswinging doors that require additional security.
- Where both Mortise Type and Cylindrical locks are used in the same project care shall be taken to assure levers align when installed. Projects in existing construction shall require field verification of existing lever locations and care taken to match existing height on new installations.
- Provide wrought boxes at strikes at wood frames or pairs of wood doors.

- Digital Locksets;

- For digital lockset needs (keyless entry) please refer to UA FM Lock Shop.

- Hospital Type Push/Pull Latches;

- Use only Glynn Johnson HL-6 with a 5" backset. Push and Pull Paddles both down. Mount Centerline at 42" Above Finished Floor (AFF).
- Where locking is required at the push/pull latch use only a Glynn Johnson HL-6 series with a Schlage L

series lock chassis. 2-3/4" backset and a 4-7/8" ASA strike. Push and Pull Paddles both down.

- Padlocks;
 - Padlocks shall be provided and keyed by the UA FM Lock Shop, where required.
- Cylinders and Keying;
 - Specify that all locks and latches be shipped without permanent cylinders unless required by the Contractor for temporary access, security and installation fit up.
 - The University will install all permanent cylinders and perform all keying.
 - Contractor to provide and install temporary construction cylinders for site security and for hardware installation, alignment and "testing".
 - Interchangeable or removable core cylinders are not employed by the University system and are not acceptable.
- Exit Devices;
 - Pre-qualified manufacturers are:
 - Von Duprin 98 or 99 series, 98-F or 99-F at Rated Openings, 33 or 35 33-F or 35-F for narrow stile. OWNER'S STANDARD, Device shall accept non-interchangeable core Medeco cylinders. Permanent cylinders will be provided by UA Facilities Management Lock Shop
 - Use the following functions and trim in the noted applications; use no other functions or trim. Cylinder dogging is not preferred and non-standard, refer to FM Lockshop.

•	Exit Only	Interior double-egress doors or other exit only doors (less dogging). <ul style="list-style-type: none">• Von Duprin 99EO(-F)
•	Exterior (key)	Doors required to be locked at all times. Vandal resistant pull on exterior. No dogging at perimeter doors <ul style="list-style-type: none">• Von Duprin 99NL (-F) x VR Pull
•	Exterior/Interior (key)	Classroom function. Key in trim locks or unlocks lever at interior exit doors from assembly spaces. <ul style="list-style-type: none">• Von Duprin 99L(-F) x 996L-R/V
•	Exterior (key)	Entrance or doors required to be locked at all times with lever pull handle. No dogging at emergency exits. <ul style="list-style-type: none">• Von Duprin 99L-NL (-F) x VR Pull
•	Corridor fire door	Passage function, use with electronic hold open devices <ul style="list-style-type: none">• Von Duprin 99L-BE(-F)
 - Use only rim devices. Size push pad portion of device to meet code requirements for Fire & Life Safety.
 - Do not use exposed or concealed vertical rod devices. Must have approval of the UA Planning, Design and Construction Project Manager where other options are not practical.
 - All exit devices must comply with applicable code and accessibility standards & requirements for the project.
 - At "Night Latch" function doors use anti-vandal type pull trim at exterior applications where needed.
 - Provide "Less Dogging" where no dogging is desired. No manual dogging allowed at rated openings. Electrified Latch Retraction devices must be tied into the life safety alarm system and release/latch upon alarm.
 - Removable mullions are to be the keyed type, Von Duprin KR__54 as appropriate for the application. At fire rated openings mullions are to be UL listed for fire, up to 3 hours.
 - At Exit Devices provide temporary construction cylinders and cores to assure proper functioning at the time of installation.

- At pairs of doors use only one pull handle on the exterior and mount device flush to the door (no gaps). This is to limit the ability to tie leaves together either by school or non-authorized personnel
- Where Access Control is required, use the HES 9600 series strike or Von Duprin 6300 as the first option with exit devices.
- Where electric latch retraction is required, use the Von Duprin Quiet Latch Retraction (QEL) device
- At fire rated doors use exit device manufacturer's electrified handled trim, 24VDC at new construction, verify voltage at existing buildings.
- Electrified Applications for access control;
 - The University preference is to use electric strikes in low or medium use applications. Use Von Duprin 6211 for mortise and cylindrical lockset applications.
 - Use HES 9600 or Von Duprin 6300 for surface mount exit device applications.
 - Extended lip strikes should be avoided. Resolve frame issues when installed in frames with surface applied trim or facings
 - Where areas require quiet hardware operation utilize the QEL exit devices or electrified mortise or cylindrical locksets.
 - At pairs of doors utilizing locksets or fire rated doors requiring 24/7 latching provide electrified locksets as listed in lockset section above.
 - REX switches are typically not integrated in the hardware. Motion REX is provided by the University's security vendor.
 - MAGNETIC LOCKS are not approved for use on campus.
- Door Closers;
 - Use only Rixson Series 27 floor closer, with top and intermediate pivots, at all public exterior doors. Do not specify non hold open Suffix "A". Okay to specify with selective hold open Suffix "S". UNIVERSITY STANDARD. NO SUBSTITUTIONS without UA FM Lock Shop approval.
 - Use LCN 4040/4041 XP, full cover, overhead closers at all other applications. UNIVERSITY STANDARD.
 - Take advantage of available arm options where appropriate for various situations. (Hold open, cushion stop, 180 degree, delayed action, etc.)
 - Extra duty arms at reverse bevel doors.
 - SCush arms at reverse bevel doors where floor stops may create a tripping hazard.
 - Provide necessary spacers, brackets, drop plates or accessories to avoid mounting conflicts with overhead stops, seals or other hardware.
 - Provide Closers at all classroom doors.
 - Require through-bolt installation at wood and non-reinforced metal doors and surface-applied installation at metal door frames. Preferred installation is on the door. If jamb mounting is necessary, all holes to be drilled and tapped. See Section 081100 for preparation and reinforcing of metal doors and frames.
 - 30 year warranty.
 - All closers must comply with ADA requirements. Door closers shall be adjusted so that from an open position of 90 degrees, the time required to move the door to an open position of 12 degrees shall be 5 seconds minimum. The force for pulling or pushing open interior hinged doors shall be 5.0 pounds maximum. Exception: Fire Doors shall have the minimum opening force allowable by appropriate administrative authority.
 - Use only wall-mounted hold open devices where doors with closers are intended to be normally open. Coordinate with Division 16 or 26, Electrical.
- Specialty Hardware;
 - Glass Doors: Use only standard and readily available hardware elements that accept standard UA Medeco cylinders. Secure approval of UA FM Lock Shop for all glass door and hardware applications. Use Blumcraft PA series bars for glass doors.

- Use AdamsRite locksets for limited applications and light duty narrow style aluminum doors.
- For roof hatches and secure access doors use UA FM Lock Shop approved Yale rim type latch or Yale rim type bolt where padlock type locking is not provided.
- All specialty hardware must accept UNIVERSITY STANDARD Medeco cylinders.

- Miscellaneous Hardware;
 - Specify all required miscellaneous hardware, including:
 - Stops (wall-type are preferred. Blocking must be coordinated, in walls, with other spec sections)
 - Kick plates on heavy traffic doors (classrooms, conference rooms, laboratories, etc.) and all wood doors with closers. Protective plates shall be a minimum of .050" thick, Beveled 4 sides and provided/installed with manufacturers standard countersunk screws. Kickplates shall be 1" Less Door Width (LDW) at pairs without mullions and 2" LDW at singles and pairs with mullions. Mop Plates shall be 1" LDW. Where armor plates are required to protect fire rated doors, they shall carry an engraved UL label.
 - Thresholds, door bottoms, and weatherstripping on all exterior doors.
 - Interior smoke and door seals surface mounted or adhesive backed. Provide frame mounted intumescent seals only where required by the door manufacturers label requirements for each opening.
 - Knox Box: Coordinate with UA Risk Management Services for proper selection of and location of Knox Box. Recess where possible.

- Double Doors;
 - Refer to Section 08000 for additional information.
 - Avoid vertical rod exit devices. Use removable mullions in most instances and only when either required for additional opening width or where the "door bank" principle cannot be applied. U of A prior approval is required.
 - At pairs of doors, where the inactive leaf is not required for egress, UA Risk Management has approved, and desires, the use of surface bolts with no door knob/lever or other surface, or mortised, hardware that would indicate this leaf is to be used for exiting. Mortised flush bolts are not to be used. Where self-latching or automatic bolts are required by code at fire rated openings this is to be reviewed with UA Risk Management for final approval. Use dust-proof strikes equivalent to Ives DP-2 where required to go into floor.
 - Where surface bolts are used they should be Ives SB360 or equal.
 - Avoid use of automatic flush bolts, except as required by code or local Authority Having Jurisdiction.
 - Avoid use of coordinators; where unavoidable, use full width units, with closer brackets, in lieu of gravity arm.
 - Where required, use only T-type astragals, provide 7/8' flat lip strike, do not notch around the strike.

- Finish;
 - BHMA 626/652 (US 26D), satin chrome plate, uncoated
 - BHMA 630 (US 32D), satin stainless steel, uncoated

- Hardware Schedule;
 - Include a specific hardware group schedule, with group designations to be used on the drawings.

- **Part 3 - Execution**
 - Coordinate with other trades (Division 6 and Division 9) location of backing required for surface applied hardware. Review finishes and floor coverings for affect to door hardware or undercuts.
 - Make sure that installation is specifically described, here or in the appropriate Division 6 section.

- Install all fire door hardware to comply with the requirements of NFPA-80-2007, Chapter 5.
- Coordinate sealing of exterior thresholds and raindrips with Division 7 – Moisture Protection.
- Coordinate Electrified Hardware with Division 16 or 26 – Electrical and Tab C-6 – Keyless Access and Security. Other affected trades for getting and installing power, j-boxes, wiring, conduit, connectors and connections to the opening or hardware whether through the walls, concrete slabs, etc shall be coordinated in the appropriate specification sections. Division of labor and materials of final electrified assembly by affected trades, for proper functionality shall be clearly defined.
- Require that all hardware including temporary test cylinders be installed, and all doors tested and adjusted for proper operation, prior to Substantial Completion.
- All door closers shall be readjusted after the air balance is complete.
- Latches shall be centered in strikes, i.e. filing of strikes is strictly prohibited.
- Demolition: All door hardware, including cylinders and cores, that are removed from existing openings shall remain the property of the University of Arizona and shall be turned over to the UA Facilities Management (FM) Lock Shop in an orderly fashion. Lock and Door Hardware removals shall be coordinated with the UA FM Lock Shop Supervisor (520) 626-1858

End of Section 08710

DIVISION 8 – DOORS AND WINDOWS

Section 08711 – Finish Hardware; Residence Life

Introduction

The University of Arizona Residence Life, has determined that, based on its experience with the performance and durability of the products described in this Section, and based on the benefits of limiting the range of repair parts which must be maintained in inventory, a proprietary specification is in the best interest of the University.

Also, to ensure compatibility of door hardware with the unique key system utilized within the University of Arizona Residence Life, specific door hardware must be used.

Specify all hardware for a fully functioning, secure, weatherproof installation for all swinging, sliding, and folding doors.

Include unique door or frame dependent hardware in those sections.
Include cabinet hardware in the appropriate Division 6 section.

In renovation projects, specify hardware which matches the existing hardware type for function, appearance, trim, and finish, except where other overriding considerations such as handicapped accessibility require deviations. The Consultant must determine the existing conditions and specify materials which match those conditions. Requiring the Contractor to “match existing as required” is unacceptable.

In special cases, hardware different from those items described below may be required. In such cases, secure specific permission of the Project Manager. These cases may include:

Alarmed exit devices
Electronic access control
Matching “period” hardware in historic buildings

Include on the drawings a schedule indicating which specific hardware group applies to each individual door. Pay particular attention to identifying the desired function of each door lockset.

Part 1 – General

- Require submittal of a complete hardware schedule describing each door and each hardware group.
- Require that the supplier of finish hardware have as a full-time employee a regular member of the American Society of Hardware Consultants, and that the hardware schedule be prepared by the AHC member.
- Require delivery to the Owner upon Substantial Completion all adjusting tools, keys, dogging keys, and other maintenance materials.

Part 2 – Products

- **Butts**
- Pre-qualified manufacturers are:
 - Hager
 - Lawrence
 - McKinney
 - Stanley
 - Minimum 1 ½ pairs per door
 - Always ball bearing
 - Always non-removable pins
 - Full length continuous hinges are **NOT** to be used without prior approval of Project Manager.
- **Closers**

- Use LCN 4040 series at all applications, unless prior approval of Project Manager.
- Non-handed, adjustable size, 4 way mountable.
- Cast iron body.
- Closers will be mounted for 180 degree opening unless configuration requires other mounting location.
- Require through-bolt installation at wood doors. Metal doors will be installed in reinforced areas. Preferred installation is on door. If jamb mounting is necessary, all holes to be drilled and tapped.
- Closers will have 10 year manufacturer warranty.
- All closers must comply with ADA requirements. ADA openings shall be equipped with DA (delay action) closers. Closure speed adjusted to 7 seconds (latching speed).
- Use only wall mounted hold open devices where doors with closers are intended to be normally open. (These units must be tied into existing fire alarm system if used).
- All closers will be readjusted upon project completion for environmental conditions in building.

- **Exit Devices**

- Pre-qualified manufacturers are:
 - Von Duprin 99 series.
 - Von Duprin 99-F for fire rated openings.
 - Von Duprin 33 Series for narrow stile.
 - Concealed vertical rod devices will **NOT** be used without prior approval of Project Manager.
 - On non-fire rated openings, key operated removable mullions will be used. (Von Duprin KR54 removable mullion).
- Use the following functions and trims in the noted applications; use no other functions or trim (these designations are based on Von Duprin products).

<u>ANSI Function</u>	<u>Trim</u>	<u>Use</u>
• 03	NL	Entrance/exit doors (non-fire rated) exterior
• 03	L-F	Stairwell doors requiring key access
• 08	L-F	Fire rated openings
• 08	L	Openings from/into conference rooms

- Use only rim devices.
- All exit devices must comply with ADA requirements.

- **Double doors**

- Refer to section 08000 for additional information.
- Use key operated mullions where ever applicable.
- Restrict use of manual flush bolts to storage and mechanical rooms. Use dust proof strikes.
- Avoid use of automatic flush bolts. Use requires prior approval of Project Manager.
- Avoid use of coordinators; where unavoidable, use full width units in lieu of gravity arm.
- Where required use only t-type astragals notched around the strike.

- **Locks and latches**

- Pre-qualified manufacturer is:
 - **Best (no substitute)**
- Use Best 93K series cylindrical locks at all general use applications.
 - Use C rose and 15 lever trim designation
 - **SFIC Interchangeable core function REQUIRED. Best specification code (7).**
- Generally use the following functions in the noted applications. Use of other functions may be required by User and Residence Life.

<u>ANSI Function</u>	<u>Best Function</u>	<u>Use</u>
----------------------	----------------------	------------

F90	T	Dormitory rooms
F109	AB	Offices
F86	D	Storerooms, closets, mechanical
F84	R	Corridors, conference rooms

- 2 ¾" backset.
- Only ANSI 4 7/8" strike (Best code S3) to be used.
- In renovation applications, comply with these requirements regardless of the style of existing locks and latches unless directed otherwise by Project Manager.
- All knobs, handles and levers shall comply with ADA requirements.
- **Cylinders and keying**
 - Specify that all locks and latches be shipped without permanent cylinders unless required by Contractor for temporary security.
 - Residence Life Access Control Systems will supply and install all permanent cylinders and perform all keying plans.
 - Require the Contractor to provide his own temporary construction, installation and testing cylinders.
 - Interchangeable SFIC format removable core cylinders are required.
- **Miscellaneous Hardware**
 - Specify all required miscellaneous hardware, including:
 - Stops (wall type preferred)
 - Kickplates on heavy traffic doors (conference rooms, corridor doors)
 - Thresholds, door bottoms, and weatherstrips on exterior doors.
 - Interior smoke seals (similar to Pemko 312, do not use adhesive application).
 - **Finish**
 - BHMA 626 (US26D), satin chrome plate, uncoated
 - BHMA 630 (US32D), satin stainless steel, uncoated
 - **Hardware Schedule**
 - Include specific hardware group schedule, with group designations to be used on the drawings.

Part 3- Execution

- Coordinate with other trades (Division 6 and Division 9) location of backing required for surface applied hardware.
- Make sure installation is specifically described, here or in appropriate Division 6 section.
- Require that all hardware including temporary test cylinders be installed, and all doors tested and adjusted for proper operation, prior to Substantial Completion.
- All door closers shall be readjusted after the air balance is complete.
- Latches shall be centered in strikes, i.e. filing of strikes is strictly prohibited.

End of Section 08711

DIVISION 08 - DOORS AND WINDOWS

Section 08720 - Automatic Door Operators

Introduction

The University of Arizona has determined that, based on its experience with the performance and durability of the products described in this Section, and based on the benefits of limiting the range of repair parts which must be maintained in inventory, a proprietary specification is in the best interest of the University.

Require automatic door operators on at least one door leaf at each entrance intended or expected to be available for general ingress/egress use. *Automatic door operator locations will be approved by the University of Arizona.*

Use sliding automatic door operators only with the specific permission of the Project Coordinator.

Do not use the following products:

- Motion detectors
- Pressure mats

Coordinate electrical requirements on the drawings.

Part 1 - General

- Require that the supplier(s) and installer(s) demonstrate 5 years of successful installations of similar systems.

Part 2 - Products

- *Approved manufacturer and models are:*
 - *Horton Series 7000 (medium duty) for interior doors, 3'-0" or smaller*
 - *Horton Series 4000 (heavy duty) for exterior doors and interior doors greater than 3'-0".*
- Generally, specify the following features:
 - Electro-mechanical, swing operation
 - Sealed transmission
 - All metal gears
 - Interior, push side, surface, top jamb, mounting
 - Key controlled power shut-off
 - 3-second "door stalled" safety feature
 - Automatic assist on manual operation
 - Remote battery operated radio frequency, square push plate control, wall mounted, 2 for each door
 - Power on/off switch accessible on surface of operator.
- Safety rails are required but need not necessarily be the door operator manufacturer's standard products. Rails may be specified to harmonize with the overall building design.

Part 3 - Execution

- There are no unique University requirements in this Section.

End of Section 08720

DIVISION 8 - DOORS AND WINDOWS

Section 08800 - Glazing

Introduction

Glass is a major maintenance issue for the University due to breakage from accidents and vandalism. The Consultant is encouraged to use light sizes which are easily replaced by the University, and carefully consider the use of any specialty glazing.

Part 1 – General

- Provide calculations for thermal stress, wind load, and structural requirements. Calculations for thermal stress should relate to partial, full and seasonal shading effects.
- Avoid the use of film applied to exposed surfaces of glass whenever possible.
- Wired (safety) glass is not allowed in any application
- Tinted/colored glass or spectrally selective glazing shall be reviewed and approved by the UA FDC Project Manager.

Part 2 - Products

- Exterior Window Openings
 - Standard Glazing: 1” insulating units with solar control low emissivity (low-e) coating
 - Use heat treated glass as required by thermal stress analysis
 - Use laminated glass for obscure or translucent glazing
 - Safety Glazing: 1” insulating glass units, where required by code, either fully tempered (FT) or laminated
 - Spandrel Glass
 - Use heat treated glass as required.
 - Space immediately behind Spandrel glass shall be adequately vented.
- Interior Window Openings
 - Standard Glazing: Annealed float or laminated
 - Use laminated glass for obscure or translucent glazing
 - Safety Glazing: where required by code, either fully tempered (FT) or laminated
- Fire-rated Glazing
 - Due to high cost of installation and replacement the use of fire rated glazing should be carefully considered during the design and approved by the UA FDC Project Manager.
 - Transparent ceramic (used as part of an insulating unit if exterior rated glazing is required).
 - Transparent wall units designed as a barrier wall (inert material turns to foam during a fire)
- Specialty Glazing
 - Coordinate approval of specialty glazing such as bullet resistant, acoustical, one way viewing, projection booths, etc. with UA FDC Project Manager to determine products that will meet specific needs.
 - Ceramic pattern may be used if reviewed and approved by UA FDC Project Manager.

- Mirror Glass: shall be framed in stainless steel and shall have a backing sheet.

Part 3 - Execution

- Mirrors shall be set with theft-proof mounting.

End of Section 08800

DIVISION 9 - FINISHES

Section 09000 - General Discussion

Introduction

Next to thermal and moisture protection, finishes are most critical to the projects' appearance over the long term. University facilities must have a useful life of forty to fifty years. Over this period of time there will be many changes and alterations to the building. Many user groups will occupy the facility and many students will pass through its doors. What the building will look like after a short or long period of time will be reflected in the selection of finishes and the ease of maintenance that can be provided by University staff. Also important in the appearance of the building will be the convenience and the availability of storage space for janitorial equipment and access to convenient janitor closets. These closets should be well thought out in the initial design and not become after thoughts randomly located. They should also not become the arbitrary repositories for miscellaneous items that were not considered in early design stages (i.e.: water heaters, terminal boards, mail cart storage, etc.).

- Excessively light or dark colored finishes should be avoided (especially black). Both are difficult to maintain.
- Ceramic tile should be applied to wall areas adjacent to drinking fountains or areas where water might splash and cause staining or deterioration of wall surfaces.
- Carpet should of a pattern, color or texture which will provide for wear and soil hiding characteristics. Buildings on the campus generally have the carpet cleaned annually. Funding for more frequent cleaning is not available.
- Appropriate materials should be considered for high traffic areas and mats or grilles should be placed at entries to facilities.
- Equally important are impervious floor covering materials at potentially wet areas such as toilet rooms, drinking fountains and adjacent to sinks in work areas and even conference rooms where coffee may be served (and spilled).
- Smooth wall surfaces are to be avoided. Patches and blemishes will show.
- Protection of walls and corners shall be provided in areas where carts or other items might damage wall surfaces. A wood base or chair rail may be appropriate in heavy duty areas.
- Marble is an absorbent material which stains easily and is difficult to clean. It should be applied to vertical surfaces only.
- Shiny, mirror like surfaces should be avoided, especially where touching is possible. These surfaces require additional maintenance and may not be maintained in the condition the designer intended.
- For flooring applications on concrete slabs on grade special precautions are typically necessary to alleviate the concerns for vapor transmission. Refer to Section 03300.
- To alleviate flooring material concerns associated with moisture transmission and emission through concrete slabs on grade the following preventive measures shall be prescribed.
 - An under slab vapor barrier should be specified and detailed directly under the concrete slab and on top of any subgrade or sand grading material to minimize moisture transmission through the slab. Vapor barrier shall meet the requirements ASTM E-1745 Class "C". Acceptable vapor barriers are "Stego Wrap" by Stego Industries and "Moistop Plus" by Forfiber Building Products Systems.
 - A low water to cement ratio, low slump concrete should be specified for all interior slabs where flooring is anticipated to minimize the amount of free water in the concrete. Sufficient time should be allowed with the project to allow any free moisture to evaporate from the slab.
 - Surface sealers may be considered for re-flooring applications on existing slabs.
- There are several types of exposed concrete floor finishes to be evaluated and considered during the design process and they are identified below. Once the design/construction team has determined which ones will be incorporated, a meeting should be scheduled to review with UA Custodial and any specialty subcontractors to guarantee compatibility of all materials and methods of maintenance.

- Mechanical Rooms: These are not maintained by UA Custodial and should be cured and sealed by the contractor. Products such as Super Aqua-Cure Vox, a high solids, water-based cure and seal, have been utilized in the past. Contractor should protect the floors during construction and clean and apply an additional coat of sealer before Substantial Completion.
- Custodial Closets and Classroom floors (if exposed plain concrete): These will be maintained by UA Custodial. Any cure and seal product needs to be compatible with Johnson Wax Carefree and High Mileage products. Contractor should protect the floors during construction and provide a clean floor floor upon Substantial Completion for final finishing by the UA prior to occupancy.
- Polished Concrete floors in high use public areas: Densified, ground, and polished concrete floors are being used more often on campus due to their appearance, durability, and reduced maintenance costs. The design/construction team should vet successful systems and requirements with local specialty subcontractors.
- The application of curing compounds and sealers can have a cosmetic effect on exposed concrete. A thin and even application by a trained professional is required.
- Alkali-Silica Reaction (ASR) is a concern on exposed concrete floors. Consideration should be taken to add 18-20% fly ash and shrinkage compensating add mixtures to the concrete mix.

Common sense should prevail in the selection of materials and consideration give to the fact that the University is a public facility used by thousands of people daily. Maintenance budgets are minimal and design elements which create hardships will not be attended to. This challenge can still foster creative ideas to resolve the design problem.

End of Section 09000

DIVISION 9 - FINISHES

Section 09100 - Metal Support Systems

Introduction

This section refers to light gauge metal framing and should use a "performance specification". Do not specify proprietary manufacturer's names or materials, and do not restrict vendors to a limited list.

Where not otherwise required by code and so to achieve greatest flexibility and cost efficiencies, non-bearing interior partitions shall be uninsulated, both sides fully sheathed, textured and painted full height terminating at the top plate 6" above ceiling, and laterally braced to structure above. Exceptions to this basic design standard requires that the Design Professional at the onset of the Schematic Design phase estimate the added cost of all interior partitions having thermal or acoustical insulation and/or extending partitions above ceilings to underside of structural deck. Approval for such exceptions is required by the PDC project manager.

In areas where partitions are subject to severe impact loads, and in situations where fixtures and appurtenances are intended to be supported directly from partitions, require the installation of backing and/or blocking in the partitions, according to the following criteria. Describe the locations for all backing and blocking on the drawings. Considerations for blocking are as follows:

Specify appropriate size/gauge of metal backing for support of heavy wall hung fixtures, handrails, etc., with a minimum load resistance capacity of 200 lbs. in any direction.

3-1/2" blocking at the bottom of heavy duty partitions where resilient floors are scheduled to be installed (to protect wall from floor cleaning equipment impacts)

Provide blocking at points of attachment for small fixtures, toilet accessories and partitions, handrails, door stops, etc. Blocking shall be 2x6 minimum fire retardant treated wood blocking or 6" wide 20 gauge (sheet metal gauge) galvanized sheet metal with a minimum wall thickness of 0.0356" (0.0400" nominal).

Coordinate this Section closely with Section 09200 Lath and Plaster and Section 09250 Gypsum Board.

Part 1 - General

- These standards shall be applicable unless the partition or wall is specifically designed otherwise.
- All cold formed steel shall comply with Steel Stud Manufacturers Association (SSMA) and American Iron and Steel Institute (AISI).

Part 2 – Products

- Prescribe all studs to be minimum 20 gauge (steel stud gauge) with minimum wall thickness of 0.0300" (30 mls). Locate all studs at 16" OC.

Part 3 - Execution

- Require that all metal support systems attached to the structure above (including floor tracks, ceiling tracks, and perimeter wall studs) be installed using only drilled anchors. Powder driven fasteners are allowed if installed with minimum 1" long shot pins (.145 shank size) are used with the correct load.
- Specify neoprene gaskets under runner tracks and perimeter studs at acoustical-rated partitions. Floor runner tracks (and some ceiling tracks) to be set in a bead of caulking.

- Specify framing intersections and special conditions as follows:
 - Three studs or floating stud at all corners
 - Double 20 gauge studs at door jambs, and each side of openings & end of wall terminations
 - Double studs both sides of expansion joints
 - Specify slip track at ceiling conditions where deflection is anticipated.
 - Provide double studs at all door openings with studs secured together on both sides.
 - Provide intermediate bracing placed at 6' OC vertically where walls exceed 12' in height. Provide minimum $\frac{3}{4}$ " cold rolled channel bridging with clips at each stud.
 - Specify blocking and attachment devices to be provided where shelves or casework are installed.
 - All walls enclosing plumbing waste or vent lines to be appropriately sized to accommodate plumbing lines and/or 6" minimum in depth unless a chase is provided.

End of Section 09100

DIVISION 9 - FINISHES

Section 09200 - Lath and Plaster

Introduction

Coordinate this Section closely with Section 09100 and other sections to which plaster and/or "stucco" may be applied.

Lath and plaster installations shall be detailed on the drawings, to the extent not sufficiently established by industry standards and to avoid misunderstandings. Pay particular attention to substrates, intersections, joints, expansion and contraction.

Avoid integral color plaster due to inconsistencies of color mixing. Apply plaster in standard gray color and finish with paint to seal and provide desired color.

Part 1 - General

- Lath and plaster work shall be in accordance with the recommendations of the following:
 - "Portland Cement Plaster (Stucco) Manual" published by the Portland Cement Association
 - "Specifications for Metal Lathing and Furring" published by the Metal Lath/Steel Framing Association, a division of the NAAMM
 - "Plaster/Metal Framing Systems/Lath Manual" distributed by the Plastering Information Bureau of California
- On major new projects, require a field constructed mock-up for verification of texture, assembly, and details. The mockup shall be maintained at the job site until the end of the project.
- Generally, remodeled plastered areas shall be plaster board with plaster finish coats as required and new plastered walls shall be the Imperial plaster board base with Imperial plaster finish.

Part 2 - Products

- Expanded metal lath shall be self-furring, 3.4 lbs./sq. yd., diamond mesh, galvanized steel sheet for exterior use and wet interior areas.
- Plaster on masonry shall be two coat type work and on wood or steel framing shall be three coat type work. Mix design shall be verified before plastering operations begin and shall include alkaline resistant glass or polypropylene fiber reinforcement strands.
- Plaster accessories shall be metal. Small-nose corner beads shall be fabricated of zinc alloy and have expanded flanges of large mesh diamond lath for plaster embedment. Casing beads shall be square-edge type.
- Expansion joints shall be one piece type in "M" shaped configuration, with expanded metal flanges, except 2-piece type may be used where expansion exceeds the one piece capabilities.

Part 3 - Execution

- Provide for expansion in exterior and interior plaster installations. Locate expansion joints where recommended by standards, but not more than ten feet on center nor defining panels greater than 100 square feet. Re-entrant corners shall have expansion joints provided.

- Moist cure Portland cement plaster in accordance with the requirement of ASTM C926, including “Annex A2 Design Considerations”

End of Section 09200

DIVISION 9 - FINISHES

Section 09250 - Gypsum Board

Introduction

This is a section where the consultant should use a "performance specification". Do not specify proprietary manufacturer's names or materials, and do not restrict vendors to a limited list.

Mechanically fastened paperless sheathing panels made of water resistant and silicone treated cores surfaced with glass mat facings with alkali-resistant coating (comparable to Dens Glass Gold Sheathing) may be specified for wall and soffit substrate construction at above grade exterior and at interior wet locations, excluding locations where tile/brick/stone clad finishes are specified. Specify Portland cement glass mesh board or lath and plaster for walls and soffits where tile, brick, and stone finishes are specified.

Describe locations for all expansion joints in gypsum board walls and ceilings on the drawings.

Coordinate this Section closely with Section 09100 Metal Support Systems.

Part 1 - General

- Identify as reference standard the criteria of the following organizations:
 - The Gypsum Association
 - The United States Gypsum Company (the non-proprietary aspects of the Gypsum Construction Handbook)
- Do not interrupt gypsum board at fire resistant partitions for blocking, ceramic tile backer boards, or other construction.

Part 2 - Products

- Require use of 5/8" gypsum board panels throughout. Allow use of 1/2" panels only in concealed conditions such as pipe chases and air plenums (subject to fire-resistant requirements).
- Specifically call for use of fire-resistant, moisture-resistant, and combination fire-and moisture-resistant panels, where required.
- Specify mold resistant and paperless board in all wet locations which shall comply with ASTM C1178/C and 1178M.
- Secure panels to framing 8 inches on center at edges and 12 inches on center within field.
- Require use of maximum practicable panel lengths to reduce number of joints.
- Specify only metal trim, joints, and accessories, designed for mechanical attachment.

Part 3 - Execution

- Specify only screw attachment for gypsum panels to both wood and metal framing, and for all trim, joints, and accessories.
- Specify corrosion resistant screws in all wet locations.
- Require that vertical joints be staggered 1/2 panel.

- Require that gypsum panels be installed continuous over openings, and extend at least 1 full stud beyond the opening edge.
- Specify "floating stud" and "floating corner" installation techniques.
- Specifically describe requirements for installation and spacing of expansion joints in walls and ceilings.
- Specify finish textures for interior spaces as follows:
 - Light skip trowel to match the Owner's sample in new areas such as offices, corridors, classrooms, conference rooms, libraries, etc.
 - Light stipple in wet or sanitary areas
 - Smooth finish, if necessary, shall be specified in Section 09200 - Lath and Plastering
 - Match existing surface textures in areas where existing walls are retained

End of Section 09250

DIVISION 9 - FINISHES

Section 09330 - Tile

Introduction

Tile work shall be designed and specified in accordance with the current edition of the Tile Council of North America (TCNA) Handbook for Ceramic Tile Installation and The American National Standards Institute (ANSI) for the materials used to install and grout ceramic tile and stone.

Indicate extent and any patterns of tile work on the drawings, including floor and wall layouts, full height or wainscot limits, tile sizes, color arrangement, perimeter conditions, interface with dissimilar materials, trim components, control and expansion joints, thresholds and setting details.

Multiple stall restrooms: indicate on drawings, full height tile (from floor to finished ceiling) at wet walls behind toilets and at side return walls at toilets, to ensure wall tile is behind all accessories such as toilet partition brackets and grab bars. Indicate full height tile behind wall hung sinks; tile above vanity counter surface to ceiling (full tile behind mirrors).

A variety of tile types may be used in combination. (Glass, matte, gloss). During the design phase, prepare a Color Board "mock up" using full size tiles to clearly demonstrate the design intent of the finished installation. Present patterns, sizes, finishes and colors using actual tiles for user group review and approval.

Trim and Accessories: Verify that matching tile trim units are available for the specified floor and wall tile. Availability: In the event matching tile trim is not manufactured, specify and detail metal or rigid PVC trim components (Products such as Schluter-DILEX-HK®, or similar) for sanitary cove base, inside and outside corners, unfinished tile edges and floor change transitions in lieu of sealant and caulk to treat such transitions.

Retrofit of existing showers in Residence Life facilities as well as new installations which provide handicapped access to showers shall be carefully studied and floor slopes, floor drain locations and waterproofing shall be carefully analyzed and detailed. Provide details for setting beds, expansion and control joints, waterproofing, and drain seals.

Linear Floor Drains (stainless steel) preferred for ganged showers.

Preferred tile sizes for shower room floors are porcelain 1" x 1" or 2" x 2" maximum and shall meet ≥ 0.42 requirement, measured per the DCOF AcuTest®, for level interior tiles that will be walked on when wet.

Pre-Installation Meeting: At least three weeks prior to commencing tile work, contractor to conduct a meeting at the project site with tile installers, architect and PD+C project manager to discuss job conditions and scope.

Part 1 – General- Considerations for Selection

- When patching tile in existing areas, develop a pattern rather than merely replacing required tile (when owner replacement stock is depleted and the original tile is no longer available or discontinued).
- Dark grout colors are preferred in areas that are routinely exposed to wet mops (floor tile, wall base).
- Polished and semi polished surfaces create a very smooth surface and are not recommended for flooring applications in areas exposed to water, oil, or grease.
- Interior public areas that are likely to be walked on when wet, shall meet ≥ 0.42 requirement, measured per the DCOF AcuTest® (Wet)
- Exterior Applications exposed to water (pedestrian plazas, pool decks) shall meet ≥ 0.60 requirement, measured per the DCOF AcuTest® (Wet) when tile size is larger than 3x3.
- Glazed floor tiles and porcelain tiles on ramped surfaces shall meet ≥ 0.65 requirement, measured per the

DCOF AcuTest® (Wet) when tile size is larger than 6x6.

- When specifying products for flooring applications, consider ease of maintenance for custodial cleaning staff. Select products that resist scratches and resist stains from soil, body oils, food and beverage spills, etc.
- Avoid caulked joint transitions at wall base as these areas deteriorate quickly when exposed to routine cleaning and must be continually maintained throughout the life of the installation.

Part 2 - Products

- Products shall meet or exceed the specified requirements of ANSI A137.1, for types, compositions and other characteristics indicated.
- Single Source Responsibility: For quality assurance, obtain each type and color of tile from a single source. Obtain each type and color of mortar, adhesive and grout from the same source.
- Products shall be suitable for a Commercial environment and for the specific usability needs of the application. Verify ASTM Porcelain/Ceramic test results for Water Absorption (ASTM C73-88) Scratch Hardness (MOHS scale rating) Breaking Strength (ASTM 648-04) Chemical Resistance (ASTM C650-04) and Abrasion Resistance (ASTM C1027-99).
- Ceramic or Porcelain tile used on floors to have MOH's Scale Hardness Value of 7 or greater and an Abrasion Resistance Classification of Class Four (4) or greater, per ASTM C1027-99.
- Non-Ceramic Trim: Satin anodized aluminum or stainless steel finish with profile that is suitable for the application at open edges of tile. Detail exposed edge protection and transition profiles at floors and corners, including but not limited to: transitions between floor finishes of different heights, between tile surface and adjoining finishes at doorways, and expansion and control joints at floors and walls.
- Stone Thresholds shall be uniform in color and finish. Marble complying with ASTM C241 for abrasion resistance and ASTM C503 for exterior use; Granite complying with ASTM C 615.
- Showers: Specify acrylic coated mold and moisture resistant gypsum panel substrate for inside shower areas. Install in accordance with TCNA Handbook Methods. Products shall comply with ASTM C1178/C, 1178M and ASTM D3273 (Products such as National Gypsum Gold Bond eXP® Tile Backer, Georgia Pacific DensShield® Tile Backer, Certainteed M2Tech® Moisture & Mold Resistant Gypsum Board, or similar).
- Specify and detail Waterproofing Membranes for shower walls and bases, pipe protrusions, inside and outside corners, curbs and wet area shower niches. (Composite sheet membrane products such as NoblelSeal TS® or similar. Liquid applied waterproofing membranes products such as Laticrete Hydro Ban®, Laticrete 9235®, RedGard®, or similar).
- Wet areas: Specify moisture resistant board as a tile backer in toilet/sink areas with limited water exposure. (Products such as National Gypsum eXP® Gypsum Board, or similar).
- Silicone sealant, moisture and mildew resistant type for shower floors and shower walls.
- Quarry or tressed paver products with matching cove base and epoxy grout is recommended for flooring in Service or Food Prep areas accumulating oils, grease and water.
- Textured or Small format tile is preferred in wet areas such as kitchens, showers, and exterior areas where rain may mix with dust and make a slick surface.

Part 3 - Execution

- Installation shall be in accordance with Tile Council of America Standards (TNCA) and shall adhere to industry installation guidelines ANSI A108, A118 and A136.

- Specify the setting method for each type tile and location by reference to TCNA standards. Generally all tile installations shall be thin set except sloped floors and shower floors where mud set shall be used.
- Setting materials, grouts and sealants shall be appropriate for the installation method.
- Coordinate and detail expansion joints with building details.
Ensure tile joints are watertight, without voids, cracks, excess mortar, or excess grout. Contractor to apply penetrating sealant (Colorless, stain-resistant sealer, not affecting color and physical properties of ceramic tile and stone surfaces). Protect finished installation until substantial completion acceptance.
- Extra stock for the Owner's use in replacement and maintenance shall be clearly labeled and consist of one (1) box or at minimum, 2 percent of each of the primary sizes and colors of tile installed as well as extra stock of adhesives, mortars, grouts and other installation materials from same production run or batch as original tile and installation materials.
- Require submission of an "as-built" color and material schedule with the project closeout documents, including:
 - Descriptive location (room number, etc.)
 - Tile (manufacturer, color and size)
 - Grout (manufacturer and color)

End of Section 09330

DIVISION 9 - FINISHES

Section 09500 - Acoustical Treatment

Introduction

The selection and specification of acoustic ceiling systems should be based on a careful analysis of functional, aesthetic, and cost criteria. Fire resistance, sound absorption, noise reduction, durability, and appearance considerations will combine to narrow selection choices to a range of a few acceptable alternatives, so that cost may serve as a final determinant to list of two or three acceptable products for bid.

Ideally the specification should be performance-based, but it is in the University's best interest in acoustical ceilings to inform bidders through semi-proprietary specifications which describe essential characteristics and name a selection of 3 or more products by different manufacturers which the Consultant has determined meet the functional and aesthetic requirements.

Acoustic ceiling material specifications should list required type, form, pattern, noise reduction coefficient or articulation class, ceiling sound transmission class, light reduction coefficient, flame spread, fire resistance classification, and sanitation. On projects with unique requirements, such as performing theater or auditorium, a special acoustic consultant should be considered to advise the Consultant in the design of the space as well as the acoustic materials of the spaces.

Part 1 - General

- Where not otherwise required by code and so to achieve greatest flexibility and cost efficiencies, non-bearing interior partitions shall be uninsulated, both sides fully sheathed, textured and painted full height terminating at the top plate 6" above ceiling, and laterally braced to structure above. Exceptions to this basic design standard requires that the Design Professional at the onset of the Schematic Design phase estimate the added cost of all interior partitions having thermal or acoustical insulation and/or extending partitions above ceilings to underside of structural deck. Approval for such exceptions is required by the PDC project manager.
- Ceilings in general areas (offices, corridors, public spaces) should generally be 2' x 4' square-edged lay-in panels.
- Ceilings utilizing special lay in panels, different sized grids such as a 2 X 2 grid, and/or enhanced acoustical ceiling tile may also be considered if the special use and added cost is approved at the onset of the Schematic Design phase by the PDC Project Manager.
- Entry lobbies and conference rooms may use tile and grids with more design oriented features.

Part 2 - Products

- Specify color/light reflectance values and noise reduction coefficients of materials specific to project's individual space requirement needs and to achieve an appropriate design versus cost balance. The following industry standard technical characteristics should be discussed with the project manager as an initial basis of design.
 - Color/Light Reflectance White/LR not less than 0.75
 - Noise Reduction Coefficient NRC not less than 0.70
 - Ceiling Attenuation Class CAC not less than 35
- Grid shall be heavy duty or intermediate

Part 3 - Execution

- Grid

- Following texturing and painting wall, screw grid to studs- stapling of grid to wall is not allowed.
 - Tie tracks and grid tightly to allow easy tile removal.
 - Wires shall not be kinked and tails shall be cut
 - Do not hang from nonstructural elements.
 - Seismic bracing is not required.
 - Powder driven fasteners are allowed if installed correctly, i.e., proper load and pin length. Otherwise drilled anchors shall be used.
 - Provide separate wires for hanging light fixtures.
 - Dimension cuts and borders. Control the grid layout with dimensions, do not rely on a “balanced” layout.
-
- Trapezes shall be installed where interference’s are encountered during the installation
 - Remodel or renovation projects may require that the existing grid be painted. Do not paint the existing tile and reuse it. Provide new tile.
 - Provide a detailed materials list with manufacturers name, lot number, stock number, name, color, etc. An extra stock of material shall be provided.

End of Section 09500

DIVISION 9 - FINISHES

Section 09650 - Resilient Flooring

Introduction

Carefully consider the areas for installation of resilient flooring. In addition to corridors, toilet rooms, elevators, classrooms, laboratories and the like, resilient flooring should be provided in work rooms, lounges, lunch rooms and areas adjacent to counter top sinks where food, beverages and the like could be spilled and soil other floor covering materials. Also consider areas in conference rooms where coffee might be served (and spilled).

Part 1 - General

- There are no unique University requirements.

Part 2 - Products

- Wall base shall be rubber cove type, 4" high. Outside corners shall be premolded.
- Flooring products
 - Flame Spread Less than 75 (ASTM E84)
 - Smoke Developed Less than 450 (ASTM E84)
 - Smoke Density Less than 450 (ASTM E84)
- Vinyl Composition Tile - FF SS-T-312, 12" x 12" x 1/8", composition 1, asbestos free.
- Sheet Vinyl - FS L-F-475, Type II, Grade A, 125 psi minimum static load limit, 0.080" thick min., 6'-0" wide, filled, without backing.
- Adhesive - Recommended by the flooring manufacturer and asbestos free.

Part 3 - Execution

- Provide 6" high integral cove base on sheet vinyl floors, with metal trim and corner shoes in laboratories and where wash downs occur. All other areas shall have standard cove rubber base.
- Floors shall be cleaned, stripped and waxed by the Contractor. Products shall be compatible with U of A custodial products. Protect until acceptance.
- Provide a detailed materials list. Provide an extra stock of materials.

End of Section 09650

DIVISION 9 - FINISHES

Section 09680 – Carpet and Carpet Tile

Introduction

In general, broadloom carpet shall be direct glue down installation.

In certain limited and special cases (for example offices of senior academic or administrative officials requiring an "executive" environment), and only with specific permission from the Project Manager, a carpet or carpet tile with enhanced cushion backing may be used. Carpet stretched over carpet padding systems should *not* be specified.

Classrooms – Where carpeting is recommended by the design professional for classroom installations, only carpet tile shall be specified. In deciding to use carpet tile in classrooms, acoustical, comfort and appearance issues should be weighed against FM maintenance issues (UA PM to coordinate). In large classrooms i.e. auditorium or tiered classrooms, the use of carpet tile is restricted to aisles and entry levels. Do not specify carpet tiles under fixed seating.

Selection of carpet materials (and enhanced cushion backing systems) must adhere to all pertinent ADA requirements.

Selection of carpet materials (and enhanced cushion backing systems) should address the traffic characteristics, likelihood and types of potential staining agents, and required longevity of the installation.

Carpet selections should take advantage of sustainable carpet options as much as possible. Manufacturer must provide Environmentally Preferred Product Declaration document listing ingredients of yarn and backing components.

When selecting carpet materials, consider that the carpet will be cleaned only annually. Specify materials choices which provide substantial wear and soil hiding characteristics. Also consider that regular vacuuming will be accomplished with heavy duty equipment. Delicate carpet requiring special attention will not prove durable.

Limit color choices to those which will provide substantial wear and soil hiding characteristics. Restrict solid color carpet to accent areas. Do not use light colors.

Where carpet is being installed directly over asbestos-containing resilient flooring ("encapsulation"), specify a releasable installation, using "peel-and-stick" materials or special adhesives. Encapsulation is decided by the University on a case by case basis.

Do not specify carpeted floor finishes in wet locations such as toilet rooms, locker rooms, wet laboratories, and other similar spaces. This includes small areas within larger spaces such as around coffee bars, drinking fountains, entry vestibules, etc.

Include carpet type, color and pattern selections, and any special layout provisions (borders, etc.) in the construction documents.

Coordinate requirements for resilient base and accessories with Section 09650.

Part 1 - General

- Require that manufacturer(s) and installer(s) demonstrate at least 5 years successful performance with similar installations.
- Require submission of manufacturer's technical literature, test reports, VOC content, and flame spread characteristics.

- Require submission of a seaming diagram, drawn to scale, clearly indicating all special features of each space required to receive a carpeted finish, and the planned seaming pattern.
- Require submission of an "as-built" color and material schedule for each carpet installed, with the closeout documents, including:
 - Descriptive location
 - Manufacturer
 - Carpet type (name and number)
 - Color, style and pattern (name and number)
 - Manufacturer's recommended cleaning procedures
 - Warranty provisions
- Require delivery to the Owner of maintenance stock, a minimum of 9 square yards or 3% of the total whichever is larger, with no individual piece smaller than 3'-0" and 9 square yards, for each type and color of carpet in the project. For small projects a minimum of 5% stock should be considered. Include the following wording with the maintenance stock specification - "It is unacceptable to consider this maintenance stock for standard installation overages. This is "attic stock" to arrive on site cleanly wrapped and labeled as "attic stock" for the client to use in future repair and maintenance. It is not considered as waste stock or overages that the contractor bids for installation purposes."
- Specify special warranty provisions as follows:
 - Two Year Installation Warranty: signed by the contractor and installer, agreeing to repair or replace defective materials and workmanship over a TWO year period.
 - 10 year, non-prorated manufacturer's warranty.
 - Delamination warranty: The backing will not delaminate for the life of the carpet.
 - Edge Ravel Warranty: The Manufacturer warrants that the carpet will not have continuous ends coming out at lengthwise seams for the life of the carpet.
 - Tuft Bind: The manufacturer warrants that the carpet has an average face yarn tuft bind of 10 pounds. This warranty is for the life of the carpet and applies only to loop pile carpet.
 - No more than 10% loss of pile by weight over the life of the carpet.
 - No zippering over the life of the carpet
 - Warranties must be from the carpet manufacturer, and must be offered as the manufacturer's warranty.
- Contact carpet consultant, Nathalie Leroux, for questions on appropriate products to meet guidelines at (nathalei.leroux@antron.net) or (619)261-1962.

Part 2 - Products

- Specify carpet, enhanced cushion backing (where required), adhesive, and seaming materials, which meet the University of Washington protocol for volatile organic compounds (voc), with the minimum possible content of voc, and in no case with a total voc content in excess of 0.50 mg per cubic meter.
- Specify carpet complying with these general criteria:
 - Flame spread - class I (ASTM E648)
 - Smoke density - less than 450 (ASTM E662)
 - Static resistance - minimum of 3.5kv (AATCC TM 134)
 - Tuft bind – minimum 10 lbs.
- High Traffic Areas (libraries, conference rooms, classrooms, corridors, etc.)

- Carpet fiber- 100% type, 6,6 BCF nylon. Hollow filament fiber shape for optimal soil hiding capability. A modification ratio of less than 1.5 Polymer identification to AATCC TM 20.
 - Dyed Method- 100% solution dyed or solution dyed yarn dye combination with a minimum of 75% solution dyed. (As long as all performance criteria are met.)
 - Construction- Tufted texture- level loop or textured loop with maximum pile height variation of 1/32 inch.
 - Stain Resistance: AATCC TM 171 (HWE) for 2 cleanings to simulate removal of topical treatments by hot water extraction, followed by AATCC TM 175 Stain Resistance test; minimum rating of 8 using AATCC Red 40 Stain Scale.
 - Soil Resistance: Soil resistance treatment to be heat cured by mill during carpet manufacturing process.
 - Texture Retention Rating: Vettermann Drum test method ASTM D5417, for 22,000 cycles with a minimum rating of a 3.0 or Hexapod Test Method, ASTM D5252, for 12,000 cycles (8.4 lb. tumbler) with a minimum rating of a 3.5. Rating using the appropriate Commercial reference Scale for the construction per ASTM D7330 test method. Testing without underpad or brushing.
 - Colorfastness to Light: AATCC TM 16.3 to 200 AFU; minimum rating of 3-4 using AATCC Gray Scale for Color Change.
 - Colorfastness to atmospheric contaminants: AATCC TM 164 (resistance to fade from oxides of nitrogen) and AATCC TM 129 (resistance to fade from ozone) for 2 cycles; minimum rating of 3-4 using AATCC Gray Scale for Color Change.
 - Colorfastness to crocking: AATCC TM 165, minimum rating of 4 using the AATCC Chromatic Transference Scale.
 - Face weight- 17 ounces per square yard minimum.
 - Primary backing- to meet warranty provisions above.
 - Secondary backing- to meet warranty provisions above.
 - Backing type- Moisture impermeable sheet backing system with welded seams or moisture impermeable carpet tile 18" to 36".
 - Dimensional stability; Aachen method/ ISO 2551. Maximum change +/-0.20%.
- General Use Areas (offices, etc.):
 - 100% type, 6,6 BCF nylon. Hollow filament fiber shape for optimal soil hiding capability. A modification ratio of less than 1.5 Polymer identification to AATCC TM 20.
 - Dyed Method- Solution dyed fiber or yarn dyed or combination of both (As long as all performance criteria are met.)
 - Construction – tufted
 - Texture- level loop or multi-level loop with maximum pile height variation of 1/16 inch.
 - Colorfastness to Light: AATCC TM 16.3 to 200 AFU; minimum rating of 3-4 using AATCC Gray Scale for Color Change.
 - Colorfastness to atmospheric contaminants: AATCC TM 164 (resistance to fade from oxides of nitrogen) and AATCC TM 129 (resistance to fade from ozone) for 2 cycles; minimum rating of 3-4 using AATCC Gray Scale for Color Change.
 - Colorfastness to crocking; AATCC TM 165, minimum rating of 4 using the AATCC Chromatic Transference Scale.
 - Stain Resistance: AATCC TM 171 (HWE) for 2 cleanings to simulate removal of topical treatments by hot water extraction, followed by AATCC TM 175 Stain Resistance test; minimum rating of 8 using AATCC Red 40 Stain Scale.
 - Soil Resistance: Soil resistance treatment to be heat cured by mill during carpet manufacturing process.
 - Texture Retention Rating: Vettermann Drum test method ASTM D5417, for 22,000 cycles (8.4 lb. tumbler) with a minimum rating of a 3.0 Rating using the appropriate Commercial Reference Scale for the construction per ASTM D7330 test method. Testing without underpad or brushing.
 - Face weight- minimum 17 ounces per square yard for broadloom and 14 ounces per square yard for carpet tile.
 - Backing- unitary or ABAC® for 12' broadloom or carpet tile 18" to 36" width.
 - Dimensional stability for tile: Aachen method/ ISO 2551. Maximum change +/-0.20%

- Hospital / Medical Facilities:
 - 100% type 6,6 BCF nylon. Hollow filament fiber shape for optimal soil hiding capability. A modification ratio of less than 1.5. Polymer identification to AATCC TM 20.
 - Dyed Method- 100% solution dyed.
 - Construction- tufted
 - Texture- level loop
 - Stain Resistance: AATCC TM 171 (HWE) for 2 cleanings to simulate removal of topical treatments by hot water extraction, followed by AATCC TM 175 Stain Resistance test; minimum rating of 8 using AATCC Red 40 Stain Scale.
 - Soil Resistance: Soil resistance treatment to be heat cured by mill during carpet manufacturing process.
 - Texture Retention Rating: Vettermann Drum test method ASTM D5417, for 22,000 cycles (8.4 lb. tumbler) with a minimum rating of a 3.5 Rating using the appropriate Commercial Reference Scale for the construction per ASTM D7330 test method. Testing without underpad or brushing.
 - Colorfastness to Light: AATCC TM 16.3 to 200 AFU; minimum rating of 3-4 using AATCC Gray Scale for Color Change.
 - Colorfastness to atmospheric contaminants: AATCC TM 164 (resistance to fade from oxides of nitrogen) and AATCC TM 129 (resistance to fade from ozone) for 2 cycles; minimum rating of 3-4 using AATCC Gray Scale for Color Change.
 - Colorfastness for crocking: AATCC TM 165, minimum rating of 4 using the AATCC Chromatic Transference Scale.
 - Face weight- 17 ounces per square yard minimum.
 - Moisture impermeable sheet backing system with welded seams or moisture impermeable carpet tile 18" to 36".
 - Dimensional stability: Aachen method/ ISO 2551. Maximum change +/-0.20%.
- Residential Living Areas (Other common areas to follow guidelines above for High Traffic Areas)
 - Because of the variety of facilities (new, renovated, need for allergy free, long term and short term) that Residence Life deals with; the Consultant shall discuss with the User the appropriate type of material to be specified for the specific project.
- Carpet with Enhanced Cushion Backing:
 - Carpet fiber- 100% type 6,6 BCF nylon. Hollow filament fiber shape for optimal soil hiding capability. A modification ratio of less than 1.5. Polymer identification to AATCC TM 20.
 - Dyed Method- solution dyed, yarn dyed, or combination of both, piece dyed or printed carpet, (As long as all performance criteria are met.)
 - Construction- tufted or woven.
 - Texture- loop pile, cut loop pile, tip-sheared loop pile, or cut pile
 - Soil Resistance: Soil resistance treatment to be heat cured by mill during carpet manufacturing process.
 - Texture Retention Rating: Vettermann Drum test method ASTM D5417, for 5,000 cycles with a minimum rating of a 3.0 or Hexapod Text Method, ASTM D5252, for 8,000 cycles (8.4 tumbler) with a minimum rating of a 3. Rating using the appropriate Commercial Reference Scale for the construction per ASTM D7330 test method. Testing without underpad or brushing.
 - Face weight- 25 ounces per square yard minimum for cut pile and 17 ounces per square yard minimum for loop pile.
 - Width- 6 foot or 12 ft. for broadloom, 18" to 36" width for carpet tile.
 - Dimensional stability: Aachen method/ ISO 2551. Maximum change +/-0.20%.
- Specify that adhesives and seam sealers must be furnished by or approved by the carpet manufacturer.

Part 3 - Execution

- Require floor leveling, for both new and renovation projects, in this Section.
- Require that installation be accomplished in accordance with manufacturer's recommendations, including seam gluing.
- Include requirements for pattern matching, color matching, and running the pile in the direction of anticipated traffic.
- Describe requirements protecting installed carpet until Substantial Completion in this Section.

End of Section 09680

DIVISION 09 - FINISHES

Section 09900 - Painting

Introduction

This Section applies to exterior and interior areas or surfaces which are intended to receive a final field painted finish. Final painted finishes serve two primary purposes:

- Provide a satisfactory protective coating for the surface
- Provide an aesthetically pleasing finish

When contemplating a painted finish for a particular surface, consider that the surface must be realistically accessible for maintenance and repainting in the future.

Develop separate specification sections for special coatings and finishes which are not traditionally considered "painted finishes," such as gymnasium floor finishes, corrosion resistant finishes, concrete floor sealers, concrete and masonry wall sealers, traffic coating, tennis court surfacing, etc.

Include a paint or finish schedule on the drawings, listing colors, locations and types of materials.

Part 1 - General

Do not specify painting for:

- Prefinished items (e.g. toilet partitions, acoustical materials, light fixtures, finished mechanical/electrical/plumbing equipment in concealed areas, etc.)
- Finished material surfaces (e.g. anodized aluminum, stainless steel, chromium plate, copper, plated hardware, rubber, etc.)
- Concealed surfaces
- Operating parts
- Identification labels
- Concrete steps, ramps, and sidewalks

Identify the Painting and Decorating Contractor's of America (PDCA) Technical Manual as a reference standard.

Require submission of manufacturer's technical information, label analysis, application instructions and Material Safety Data Sheets (MSDS) for each material proposed. Include cross reference to the specific finish system(s) and substrate(s).

Where precise color requirements are involved, specify a three-step color selection and approval process, including:

- Selection from manufacturer's color chips
- Verification from 12"x12" draw down cards
- Final confirmation from actual samples in the field
Field samples shall encompass at least 100 square feet, be applied on the actual substrate, utilize the entire finish system, and produce the required sheen, color and texture under (simulated) final lighting conditions.

When epoxy or lacquer materials are specified, include a requirement for providing positive ventilation of the spaces and a requirement that the application be made after 5:00 p.m. on Friday (to allow odors to dissipate over the weekend).

Require submission of an "as-built" color and material schedule for each substrate and finish system with the project closeout documents, including:

- Descriptive location (room number, etc.)

- Manufacturer
- Paint type (name and number)
- Color (name and number)

The use of recycled paint may be considered for only primer coats and block fillers. Review with the UA Project Manager for a final determination.

Consider the use of plastic or metal corner guards on outside corners of painted walls to protect finish.

Part 2 - Products

Pre-approved paint manufacturers are: Dunn Edwards Corp., Frazee and Sherwin-Williams Paint Co. For exterior stain, add Olympic. See Table 1 for a description of product types and application.

Specify only manufacturer's first quality top-of-the-line products as described in the PDCA manual.

Specify only materials which comply with all VOC regulations promulgated by the Environmental Protection Agency, and as required for USBBC LEED certification (when applicable).

Specify colors from manufacturer's complete standard range. Do not custom match paint colors to other materials unless approved by the UA Project Manager. Limit the use of deep tint base colors to interior wood and metal trim only.

Specify a minimum of 1 coat of primer and 2 coats of finish on all new and existing surfaces.

Specify complete paint systems (primers and finish coats) for each substrate and finish.

Specify only primers which are specifically intended for each substrate.

For interior gypsum board walls and ceilings in the following locations use low sheen vinyl acrylic or acrylic paint (See Table 1):

- Classrooms
- Offices
- Corridors
- Stairs
- Dry laboratories
- Janitor closets
- Storage rooms
- Equipment rooms
- All other high use areas

For interior gypsum board ceilings in the following locations use semi-gloss enamel (See Table 1):

- Toilet room ceilings

For interior gypsum board walls and ceilings in the following locations use semi-gloss epoxy (See Table 1):

- Wet laboratories (walls only)
- Animal care areas
- Certain medical care areas
- Shower rooms
- All other areas exposed to substantial moisture

Part 3 - Execution

Specify required protection of adjacent surfaces, and removal/replacement of appurtenances.

Require that product data and MSDS for each material being used are available on the site.

Specify priming, painting, and finishing of all painted surfaces, covering in detail:

- Required surface preparation (for all new and existing surfaces)
- Application techniques
- Drying times
- Sanding
- Recoating
- Minimum number of coats

Require that all gypsum wallboard receive PVA primer prior to texture. Gypsum wallboard to receive additional primer coat after it is textured, and prior to the application of the first coat of paint.

Make reference and specify the techniques found in the PDCA manual for a "type 1 standard job".

Include a requirement that each primer and finish coat be inspected through the University's inspection process prior to application of the succeeding coat, and that the color of each coat be slightly varied.

Prior to painting/finishing of metal components, painter to verify that all top and upper surfaces have been seal welded.

Table 1 - Paint List

	General Description	Dunn Edwards	Sherwin Williams
INTERIOR			
Concrete Masonry Block			
Block Filler (Primer)	Smooth Block Filler	Smooth Blocfil SBSL00, MPI #4	B25W25 PrepRite Latex Block Filler
Eggshell	100% Acrylic	Spartashield SSSL30, MPI #161	A75 Series SOLO® 100% Acrylic Interior/Exterior Eg-Shel
Epoxy - eggshell	Epoxy	Carboline Sanitile 255	B73-360 Series Pro Industrial™ Water Based Catalyzed Epoxy Eg-Shel
Epoxy for Healthcare (0 VOC) - eggshell	Epoxy	Monopole Monochem 200	
Gypsum Wallboard			
Primer	PVA	Vinylastic	
Eggshell (standard)	Vinyl Acrylic	Spartawall 30 Spartazero	B20-2600 Series ProMar® 200 Zero VOC Interior Latex Eg-Shel
Eggshell (standard)	Vinyl Acrylic - VOC Absorptive		B09-1000 Series Harmony® 100% Acrylic Interior Acrylic Eg-Shel
Eggshell (alternate) <i>Previous UA standard, no longer required, may be specified if recommended by UA Project Manager or Design Professional</i>	100% Acrylic	Spartashield SSSL30, MPI #161	A75 Series SOLO® 100% Acrylic Interior/Exterior Eg-Shel
Semi-gloss	100% Acrylic	Spartawall SWLL50, MPI #153	A76 Series SOLO® 100% Acrylic Interior/Exterior Semi-Gloss.
Flat (only when approved by PDC)	Vinyl Acrylic	Spartawall 10	B30-2600 Series ProMar® 200 Zero VOC Interior Latex Flat
Flat (only when approved by PDC)	100% Acrylic	Spartashield 10	A74 Series SOLO® 100% Acrylic Interior/Exterior Flat.
Epoxy - eggshell	Epoxy	Carboline Sanitile 255	B73-360 Series Pro Industrial™ Water Based Catalyzed Epoxy Eg-Shel
Epoxy for Healthcare (0 VOC) - eggshell	Epoxy	Monopole Monochem 200	Pro-Industrial Catalyzed Water Based Epoxy
Metal - Steel			
Primer	Primer	Bloc-rust	B66-310 Series Pro Industrial™ Pro-Cryl® Universal Primer
Semi-gloss	100% Acrylic	1. Evershield 2. Spartashield 50	1. B66W350 Series Sher-Cryl™ HPA High Performance Acrylic Semi Gloss. 2. A76 Series SOLO® 100% Acrylic Interior/Exterior Semi-Gloss
Semi-gloss (0 VOC)	100% Acrylic	Ultrashield	
Wood Trim			
Semi-gloss	100% Acrylic	Spartawall SWLL50, MPI #153	A76 Series SOLO® 100% Acrylic Interior/Exterior Semi-Gloss.

Table 1 - Paint List

	General Description	Dunn Edwards	Sherwin Williams
EXTERIOR			
Masonry			
Block Filler	Smooth Block Filler	Smooth Blocfil SBSL00, MPI #4	B25W25 PrepRite Latex Block Filler
Primer	Primer	Eff-stop primer ESSLOO	A24W8300 LOXON® Concrete & Masonry Primer/Sealer Interior/Exterior Latex
Flat	100% Acrylic	1. Acri-hues ACHS10 2. Evershield EVSH10	1. A-100 Exterior Latex Flat, A6 Series 2. Upgrade Option- K47 Series Emerald™ Exterior Acrylic Flat
Stucco			
Primer		Eff-stop primer ESSLOO	A24W8300 LOXON® Concrete & Masonry Latex Primer/Sealer Interior/Exterior.
Flat	100% Acrylic	Evershield EVSH10	1. A-100 Exterior Latex Flat, A6 Series 2. Upgrade Option- K47 Series Emerald™ Exterior Acrylic Flat.
Metal - Aluminum			
Primer	Primer	Ultra-grip	B66-310 Series Pro Industrial™ Pro-Cryl® Universal Primer.
Semi-gloss	100% Acrylic	1. Evershield EVSH50 2. Spartashield 50	1. B66W350 Series Sher-Cryl™ HPA High Performance Acrylic Semi Gloss. 2. A76 Series SOLO® 100% Acrylic Interior/Exterior Semi-Gloss
Semi-gloss (0 VOC)	100% Acrylic	Ultrashield	
Metal - Steel			
Primer	Primer	Bloc-rust	B66-310 Series Pro Industrial™ Pro-Cryl® Universal Primer
Semi-gloss	100% Acrylic	1. Evershield EVSH50 2. Spartashield 50	1. B66W350 Series Sher-Cryl™ HPA High Performance Acrylic Semi Gloss. 2. A76 Series SOLO® 100% Acrylic Interior/Exterior Semi-Gloss
Semi-gloss (0 VOC)	100% Acrylic	Ultrashield	
Wood Trim			
Primer	Primer	Ez prime EZPROO	B51-8000 Series Multi-Purpose Latex Primer Interior/Exterior
Semi-gloss	100% Acrylic	1. Evershield 2. Spartashield 50	1. B66W350 Series Sher-Cryl™ HPA High Performance Acrylic Semi Gloss. 2. A76 Series SOLO® 100% Acrylic Interior/Exterior Semi-Gloss

End of Section 09900

DIVISION 9 - FINISHES

Section 09950 - Wall Coverings

Introduction

The use of wall coverings is not standard in University work and should be reviewed with the Project Coordinator. They shall not be used as a wainscot and should only be considered for aesthetic reasons in special purpose areas such as executive offices, conference rooms and lobby areas not subject to abuse. Papers, foils and flocks are not permitted.

Part 1 - General

- Tackable materials should be considered
- Cross reference this section with Corner guards, if used.

Part 2 - Products

- Vinyl materials shall be minimum 54 oz.
- Oil base primer or enamel undercoater shall be used to "size" the wall surface.
- Adhesive shall be manufactured or approved by the covering manufacturer.

Part 3 - Execution

- Install covering over abandoned outlet boxes. Fill openings if permanent.
- Only vertical joints are permitted.
- Doublecut joints with a straight edge.
- Pattern match, if critical, shall be mentioned in the specification and if necessary to rotate alternate sheets so same edge abuts same edge of roll, it should be so specified. to avoid gradations in match at seams.
- Manufacturers data sheets shall be provided and a minimum of 9 square yards of each color and type of wall covering used in the project shall be provided as extra stock.

End of Section 09950

DIVISION 10 - SPECIALTIES

Section 10000 - General Discussion

Introduction

The products specified in Division 10 are the pieces and parts that make up the finishing touches of a project. In many cases they make the room or spaces functional. High quality, serviceability, maintainability and extended product life are the needs upon which this Section is developed. In some cases qualitative standards are cited for an item(s) and in others, specific product names and manufacturers are cited. When the product or item is cited by name, it is the intention that the name/item(s) be incorporated into the project. In such cases the University maintain "in-house" expertise, parts and maintenance stock to service the item. Further, it is in the best interest of the University to have consistency if only from the standpoint of the sheer logistics of maintaining and supplying its many buildings.

The consultant should select from the range of products and review and coordinate with the Project Manager and Users to determine any special requirements or features for the project.

Chalkboards, Markerboards, and Tackboards

These items, as specified, conform to the University Classroom Design Standards. They are fairly standard and should be specified, sized, selected and customized based on User need and preferences.

Toilet Partitions

Metal toilet partitions are the product of choice for the University. These have proven to be the most vandal resistant, repairable and serviceable of all the products now in use on campus. However there are other applications where metal is ill-advised and may be subject to wet or *corrosive conditions* in excess of normal conditions such as locker rooms and pool areas. In such conditions *solid plastic panel partition systems* will be acceptable. Plastic laminate clad wood or particleboard shall not be specified or used.

Corner Guards

Corner guards are a practical solution to a major problem in high use public areas and corridors, in particular where cart and rolling traffic is present. The selected product should be carefully considered and attention to detailing at the tops (where a radius may meet a ceiling grid) and bottoms (where base materials may wrap or butt). Termination of wall coverings at corner guards should also be studied and detailed. Color of materials must also be considered for match or contrast with adjacent surfaces.

Signage and Graphics

Example of comprehensive signage package is incorporated into the Section. Room names and numbers as they appear on the drawings may not be the same as that used by the University for identification. This should be verified prior to submittal of shop drawings. A schedule showing all of the signs required, as well as the type together with location plan must be included. This comprehensive signage package must be included regardless of who provides the signage, be it the University or an outside vendor.

Letters and Plaques

Location of letters and building name shall be coordinated with the Project Manager. Recently, building identification has been accomplished with free standing signage. If letters are provided, size shall be at least 8". Style of letters shall be reviewed by Project Manager.

Directories and Bulletin Boards

Design should compliment the building. Size and location of directory and bulletin board should be coordinated with the User and the Project Manager. Adequate sizes shall be established to allow for building growth and sufficient sets of letters shall be provided with the units. Size of letters and tactile marking to comply with ADA requirements shall be considered by the Consultant. Units must be of vandal proof construction.

Fire Protection Devices

Fire extinguishers will be provided and installed as a part of the construction contract. Type shall be selected as appropriate for the class of equipment being served. Locations shall be shown on the drawings and coordinated with the University's Risk Management department.

Toilet Accessories

Occasionally requirements will vary depending upon whether the project is located on the Main Campus, AHSC, or within a Residence Life Facility. Verify with Project Manager of specifics.

End of Section 10000

DIVISION 10 - SPECIALTIES

Section 10100 - Chalkboards, Markerboards and Tackboards

These items should conform to the University Classroom Design Standards. The products are fairly standard and should be specified, sized, selected and/or customized based on the User's needs and preferences with the concurrence of the University Teaching Center.

Part 1 - General

- Markerboards are preferred over chalkboards primarily because of the problems associated with chalk dust. The University is gradually migrating in this direction but there may be instances where chalkboards are more desirable. Chalkboards should be avoided when an appreciable amount of computer and audio visual equipment is used in the area.
- Locations, mounting heights and sizes should be clearly shown on the drawings and elevations.

Part 2 - Products

- Chalkboards and markerboards (whether fixed or moveable) shall be of 3-ply construction consisting of a face sheet, core material and backing.
 - Face sheet shall be one piece 24 gauge porcelain enamel steel skin (magnetic) with appropriate fused surface for either chalkboards or dry erase markerboards. Surface for chalkboards shall be similar to "Vitracite" by Claridge with matte finish, color: Black only. Surface for markerboards shall be similar to "LCS" by Claridge with high gloss finish intended for use with liquid felt-tipped markers, color: White or Light Gray.
 - Core for fixed units shall be minimum 3/8" particle board or Duracore. Core for moveable units shall be minimum 3/8" heavy kraft paper honeycomb.
 - Backing for fixed units shall be aluminum foil. Backing for moveable units shall be 26 gauge galvanized steel sheet.
 - Accessories (fixed boards): Provide continuous extruded aluminum chalktray at bottom of board. Provide cork tack strip along top of board with sliding map clips every twelve inches.
 - Aluminum frame and accessories shall be clear anodized aluminum finish.
- Moveable units should be manually operated, vertical sliding, multiple 2 or 3 tack, counterbalanced with shielded ball bearing pulleys and aircraft cable supporting wires. Horizontal sliding units should be avoided. Operation should be easy and quiet with no rattling of panel within the track. Provide units with integral continuous chalktray. Motorized vertical units may be considered depending on the application with the approval of FM.
- Vertical sliding units may either be surface mounted or floor mounted with a kick panel. In either case the back fixed surface should be utilized as a similar writing surface or a projection surface. Bare walls behind the vertical sliding units should be avoided. Kick panel surface should be specified to compliment the adjacent finishes.
- Any individual unit should not be larger than 16 feet long.
- Tackboards should be natural cork product combined with linseed oil laminated on a burlap backing with natural pigments that go through to the backing. Preferred color is tan. Product shall be self healing, soil resistant, washable, have a low light reflectance and not contain any toxins or harmful emissions. Minimum thickness of cork should be 1/4". Boards may be additionally mounted on hardboard backing for rigidity.

Part 3 - Execution

- If a projection surface is intended behind vertical sliding units, care must be exercised to insure that the height of the markerboard are sufficient to serve this purpose. A general rule is that the top of the screen surface should be no less than the centerline of the projector lens.
- Provide the maximum manufacturer's available guarantee.

End of Section 10100

DIVISION 10 - SPECIALTIES

Section 10160 - Toilet Compartments

Introduction

Toilet compartments are subject to considerable use, damage and vandalism. Consequently they need to be given considerable attention to insure that they will withstand this abuse and not present a constant maintenance burden.

Wood and wood laminate partitions are not to be used.

Part 1 - General

- Toilet compartments are subject to vandalism and therefore must be adequately braced and constructed of material that is not easily defaced or deformed.

Part 2 - Products

- Toilet partitions, compartments, doors and screens should be constructed of standard fabricated hollow metal, *high density polyethylene or solid phenolic panels*. Customized shapes and configurations should be avoided.
- Metal panels are best fabricated from heavy gauge brushed stainless steel as it the most resistant to defacing and easiest to clean and maintain. Painted or enameled metal panels are discouraged as they are easily defaced.
- Partition supports and pilasters should at least be specified for floor and wall attachment. Additionally attach to ceiling bracing if possible. Partitions which are attached only to the ceiling and walls must be avoided. Provide anti-grip type overhead braces over door openings.
- Pilaster shoes and caps should be attached with manufactured clips.
- All fasteners and assembly screws shall be tamper proof. Partitions shall be attached to wall with no less than three brackets. Brackets shall be secured with no less than two fasteners.
- All hardware shall be heavy duty institutional type. Door hinges shall be adjustable self closing.
- Doors on HC stalls shall be out-swinging. Doors on regular stalls shall be in-swinging. Provide pulls on both sides of out-swinging doors to handicap stalls.
- Screens shall be attached with wall brackets and a front supporting post secured to the floor to provide additional resistance from lateral impact.

Part 3 - Execution

- Adjust hinges so that both in-swinging and HC out-swinging doors remain open at a 30 degree angle when unlatched. All partitions, compartments and doors shall be installed so all edges are plumb, level and parallel. Protect during construction and clean prior to acceptance.

End of Section 10160

DIVISION 10 - SPECIALTIES

Section 10260 - Wall and Corner Guards

Introduction

Corner guards are a practical solution to a major problem in high use public areas and corridors. The selected design should be carefully considered and attention to detailing at the top (where a radius may meet a ceiling grid) and bottom (where base materials may wrap or butt) must be studied. Corner guards should never terminate part way up a wall. Termination of wall coverings at corner guards should also be studied and detailed.

Part 1 - General

- Color of materials must be considered for match or contrast with adjacent surfaces.

Part 2 - Products

- Generally a heavy gauge brushed stainless steel corner guard with rounded corners is preferred.
- Heavy duty textured snap-in PVC materials on an aluminum retainer may be considered where color or a flush appearance is important.

Part 3 - Execution

- Manufacturers installation literature shall be followed with sufficient backup provided for support.
- Care shall be taken not to void fire ratings of walls.

End of Section 10260

DIVISION 10 - SPECIALTIES

Section 10293 – Bird Control

Introduction

Pigeon roosting and congregation is an ongoing problem at the University. Specify appropriate bird control systems whenever conditions are created that might enable pigeon roosting or congregation over occupied or pedestrian areas or where resultant roosting will create unsightly conditions. Areas where food service is available may need extra special attention.

Part 1 - General

- Generally, ledges, window sills, overhanging shade devices, roof peaks and edge conditions should be evaluated for application.
- For small isolated areas, parapet walls and roof edges, a stainless steel bird spike system may be sufficient.

Part 2 – Products

- For larger overhangs or window sills or where deterrence has been identified as a special requirement, a low voltage electric system such as the Avian Averting System® by Avian Flyaway, Inc is recommended. Contact information is as follows:

Avian Flyaway, Inc.
Western Regional Office
1645 W. Valencia Rd.
Suite 109-514
Tucson, AZ 85746
Phone: (520) 889-7303
Fax: (520) 889-1375
<http://www.avianflyawayinc.com/>

Part 3 – Execution

- No discussion

End of Section 10293

DIVISION 10 - SPECIALTIES

Section 10410 - Directories and Bulletin Boards

Introduction

Design should compliment the building. Size and location of directory and bulletin boards should be coordinated with the User and the Project Manager.

Adequate sizes shall be established to allow for building growth and sufficient sets of letters shall be provided with the units. Size of letters and tactile marking to comply with ADA requirements shall be considered.

Part 1 - General

- Units shall be vandal proof construction

Part 2 - Products

- There are no unique University requirements.

Part 3 - Execution

- Mounting shall be concealed and vandal proof.

End of Section 10410

DIVISION 10 - SPECIALTIES

Section 10420 - Dedication Plaque

Introduction

A cast metal dedication plaque has traditionally been required on all capital ABOR projects.

The dedication plaque shall be furnished and installed as part of the construction project.

Part 1 - General

- Plaque shall be identified on the drawings and located near the building entrance, just inside or outside of the main entry doors. For building additions, the location of the new plaque shall not conflict with or replace the location of the existing plaque(s).
- University of Arizona DSS Detail 10420-D1 shall be used to provide a dimensioned elevation view and details of the plaque in the project specification. No deviations from this standard will be allowed for new buildings. For building additions endeavor to match the details of the existing original plaque(s).
- Text for plaque shall be furnished by the University and adhere to the following traditions:
 - The date shall be the year in which the construction effort was complete.
 - The names of the Governor, members of the Board of Regents and President of the University are those that held office at the time the construction contract was awarded.
 - The above information as well as the name of the building shall be verified in writing with the University of Arizona President's Office via the office of the Senior Vice President of Business Affairs.
 - The names of the Architect, Contractor and Construction Manager (if applicable) shall be the same as that contained in their respective contracts.
 - Exact text for plaque will typically not be available at the time the project is bid. Consequently, for estimating and bidding purposes, only an example of the text can be provided or an allowance of 400 letters established. Exact text shall be confirmed as part of the shop drawing review process.
- Shop drawing submittal shall include an accurate scaled drawing of the plaque showing complete layout and size of text as well as large scale details of letters, border style and anchoring method.

Part 2 - Products

- Refer to dedication plaque drawing 10420-D1 for details and attributes of plaques.
- One vendor that has been used for past University dedication plaques is A.R.K. Ramos. Their contact information is:

A.R.K. Ramos Signage Systems
P.O. Box 26388
Oklahoma City, OK. 73126

Phone 405-235-5505
Toll Free 1-800-725-7266
Website www.arkramos.com

Part 3 - Execution

- After installation clean and protect plaque until final acceptance by the University.

UA BUILDING DEDICATION PLAQUE:
Material: Cast aluminum
Border: Plain (square) border profile, painted black
Field: sandblasted aluminum finish, A.R.K. Ramos "matte" texture
Font: Milo, sans serif, recessed letters painted black
Logo: Standard UA Block A (3-1/4" H)
Mounting: Concealed anchor

Cast aluminum plaque should be used for new buildings and modern additions to non-historic buildings. Cast bronze should be used for additions/alterations to historic buildings.

SECTION DETAIL

FONT SIZES

- 1- 1/8"
- 1-1/2"
- 1"
- 3/4"
- 5/8"
- 3/4"
- 5/8"
- 1- 1/8"
- 3-1/4"

THE UNIVERSITY OF ARIZONA
ENVIRONMENT & NATURAL RESOURCES 2

ARIZONA BOARD OF REGENTS
 JANICE K. BREWER, GOVERNOR
 RICK MYERS, CHAIR

TYLER BOWYER
 DENNIS DeCONCINI
 JAY HEILER
 MARK KILLIAN
 RAM KRISHNA

LUANN LEONARD
 ANNE MARIUCCI
 GREG PATTERSON
 KAITLIN THOMPSON
 JOHN HUPPENTHAL

ANN WEAVER HART
 PRESIDENT OF THE UNIVERSITY

GLHN ARCHITECTS & ENGINEERS
 RICHÁRD + BAUER ARCHITECTURE LLC
 _____ ARCHITECT

HENSEL PHELPS CONSTRUCTION COMPANY
 _____ CONTRACTOR

_____ 2015

THE UNIVERSITY OF ARIZONA	
MANUAL OF DESIGN SPECIFICATION STANDARDS	
STANDARD DETAIL: DEDICATION PLAQUE	
DRAWN BY: E. GALDA	DETAIL NO.
APPROVED BY: B. DOLAN	10420-D1
July 2015	
REVISIONS	

End of Section 10420

DIVISION 10 - SPECIALTIES

Section 10430 – Exterior Signs

Introduction

All exterior signs shall comply with the University Identification Guide, Section II – Exterior Signage Guide.

Part 1 - General

- Compliance with the Exterior Sign Manual is to ensure the implementation of a comprehensive and consistent campus-wide exterior sign program including but not limited to: identification, directional, informational, and regulatory signs.
- Generally, projects that entail new facility construction, additions to existing facilities, facility renovations that involve change of use, site modifications, and other similar work will require new exterior signage or changes to existing exterior signage.
- Where exterior signage is required, it will be the responsibility of the project to include exterior signage in the Scope of work and the project budget.
- It shall be the responsibility of the Design Consultant in conjunction with the User to first identify and then document the extent, location, size, text, graphics, color, materials and other signage elements consistent with the criteria in the Exterior Sign Manual.
- It is recommended that signage development be initiated early in the design of the project.
- All Exterior Signage must be reviewed and approved by The University Sign Committee per the Sign Review Procedures detailed in the Exterior Signage Guide.
- Copies of the Exterior Signage Guide should be obtained and coordinated through the FDC Project Manager.
- In general, most exterior signage will be fabricated and installed by The University's Facilities Management shops following Sign Committee approval and processing the necessary Work Orders through Facilities Management. The FDC Project Manager should assist the Design Consultant in segregating and budgeting exterior signage that will be under the contract for construction versus via Work Orders to University personnel. The FDC Project Manager shall issue the Work Orders.

Part 2 - Products

- No discussion

Part 3 – Execution

- No discussion

End of Section 10430

DIVISION 10 - SPECIALTIES

Section 10520 - Fire Protection Devices

Introduction

Fire extinguishers shall be provided and installed as a part of the construction contract. Type shall be selected as appropriate for the class of equipment being served.

Locations shall be shown on the drawings.

Part 1 - General

- Cabinets shall be large enough to contain a 10# dry chemical type extinguisher. Coordinate wall thickness to insure adequate depth is provided.
- Mounting brackets shall be provided for extinguishers not located in cabinets.

Part 2 - Products

- Fire extinguishers shall generally be multi-purpose dry chemical type, UL rated, 4-A:60-B:C, 10lb nominal capacity, in enameled steel container for Class A, Class B and Class C fires.
- Fire extinguisher cabinets shall be either semi or fully recessed type with enameled steel box. Exposed trim, door material, door style and hardware shall be as selected by the Consultant and appropriate to the design of the building. Lobbies, public spaces, corridors and the like may have upgraded materials in keeping with the building design. In less public areas, polished, non-directional #4 stainless steel should be considered for door material.

Part 3 - Execution

- Securely fasten mountings to building.
- Cabinets shall be identified with lettering spelling "FIRE EXTINGUISHER".

End of Section 10520

DIVISION 10 - SPECIALTIES

Section 10810 - Toilet Accessories

Introduction

This section addresses the type of accessories which are to be provided or anticipated for all new and remodeled restrooms. The following accessories requirements are for toilet rooms which will be serviced and maintained by Facilities Management.

Pre-installation meeting with contractor, PD&C Project Manager and DRC / Sherry Santee is required to confirm the locations and mounting heights of all accessories.

Requirements for toilet accessories may vary depending upon whether the project is located on the Main Campus, at AHSC or within a Residence Life Facility. All assumptions shall be verified with the PD&C Project Manager and the respective custodial group.

Facilities Management administrates annual contracts for the furnishing of paper towels, hand soap and toilet tissue. Consequently these respective dispensing elements are supplied by the vendor or FM Custodial Services.

Part 1 - General

- For new and renovation projects, FM Custodial Services will provide as part of FFE, hand soap, paper towel and toilet tissue dispensers for installation by the contractor. Consultant to note these three items in project specifications and Toilet Accessories Schedule as "OFCl". All dispensing units shall be surface mounted. Recessed elements are to be avoided. Stud walls should receive appropriate blocking to accommodate surface mount attachment.
- Free-standing Trash receptacles are to be located or at least anticipated in every restroom.
- Counter mounted pump type soap dispensers are not used on campus.
- Provide an Accessories Schedule in the specifications or on the drawings listing each room and the quantity of each type of accessory required as well as who provides what elements and who installs.
- Consultant should anticipate and coordinate locations for any other miscellaneous owner furnished elements.

Part 2 – Products / Space Planning

- Paper towel dispensers (FM Custodial Services will provide as part of FFE). For space planning purposes, dispensers shall be surface mount, high impact plastic with push button operation. Kimberly Clark "in Sight Sanitouch" or Georgia-Pacific push paddle dispenser. Confirm current model with FM custodial during design phase. Paper towel dispensers project approximately 12 inches into the floor space and therefore should not be installed in the path of travel. Position dispensers adjacent to sink on side return walls where possible and ensure dispenser does not overlap the 30 x 48 wheelchair clear space at sink. Provide at least one paper towel dispenser for every three sinks and install with operable mechanism at 42" max. above the finished floor.
- Where provided, electric hand dryers with bottom air outlet shall be located so that operating mechanism is at 40" above the finished floor. Hand dryers that hands are inserted into, shall be located so that top of unit is 36" above the finished floor.
- Soap dispensers are provided by Custodial Services via their soap vendor and are surface mounted (GOJO brand approx. dimensions 9Hx6Wx5D); confirm current model with FM custodial at time of design. Install "front reach" soap dispensers on sink walls at a consistent low height; at the top of the backsplash or adjacent to mirrors. Provide one soap dispenser adjacent to a sink on the side return wall where possible, to reduce length of reach. Locate operable mechanism at 42" max. above the finished floor.

- Toilet Paper Dispensers will be provided by Custodial Services as part of FFE. For space planning purposes, dispensers shall be surface mounted, Georgia Pacific Compact Quad Vertical Four Roll Coreless type for regular toilet stalls; Compact Side by Side Double Roll type for wheelchair accessible stalls, accessible ambulatory stalls and accessible single occupant toilet rooms. Install the Side by Side Double Roll dispenser at 7 inches from the front of the bowl measured from the centerline of the dispenser and with the top edge of the dispenser at 1-1/2" below the grab bar. NOTE: Quad / Four Roll dispenser types are NOT allowed in wheelchair accessible stalls, accessible ambulatory stalls or accessible single occupant toilet rooms.
- Sanitary Napkin disposal units: (FM Custodial Services will provide free-standing floor boxes as part of FFE). For a surface mounted option, consultant to specify Bobrick Contura Series B-270 in stainless steel finish. (FM custodial provides the trash bag liners but does not supply the dispenser). Handicap Accessible stalls and Ambulatory stalls: install unit toward the back of stall, behind the toilet paper dispenser with 1 1/2" CLEARANCE UNDER THE GRAB BAR WITH THE LID UP. At regular stalls, install unit toward the front of stall, in front of the toilet paper dispenser.
- Waste receptacles will be provided by Custodial Services as part of FFE and will typically be a free standing "Slim-line" type unit for most restrooms. Recessed or wall mounted receptacles are not acceptable. Under-counter trash receptacles with a countertop cutout are acceptable. Consultant to anticipate space planning for trash receptacles to ensure the layout meets accessible clear floor space requirements, particularly for waste receptacles adjacent to entry/exit doors.
- Grab bars shall be stainless steel, 18 gauge minimum wall thickness, 1.5" minimum outside diameter with concealed mounting devices. Install to provide 1.5" clearance between wall and inside face of handrail. Provide vertical grab bar at water closets in wheelchair accessible, accessible ambulatory stalls and accessible single use restrooms. Comply with ANSI standards for size and placement of vertical grab bar.
- For accessible toilet partition doors that swing out: specify two additional pulls on the interior side of the stall door. Install one pull below the door latch and the other pull 8" in from the latch side. Specify non-standard hardware that allows for additional clear space between the pull and face of door (3 inches min. clear).
- Coat Hooks: specify one hook for each partition door. Specify one hook in the center of the door at 42" AFF at all accessible and ambulatory stall doors. Where occurs, specify one towel / coat hook at all showers at 42" AFF.
- Mirrors shall be 1/4" glass with stainless steel frame and concealed fasteners. Locate and size mirror to provide adequate free wall space for soap dispenser. Provide full length framed mirror in multi-stall restrooms.
- Baby Changing Stations: Koala Kare Products KB200 horizontal wall mounted, surface mounted and constructed of injection-molded polypropylene. Color to be selected by architect from standard finishes. Install with the changing surface at 34 inches above the finished floor (measured at open/lowered position). Stations cannot be located in accessible stalls.

Part 3 - Execution

- Provide stud wall backing for all surface mounted accessories.
- Protect all toilet accessories from damage during the course of construction.
- Clean all surfaces in strict accordance with manufacturer's recommendations after removing temporary labels and protective coatings.
- Locate all accessories to ensure that surface mount elements are cane detectable, do not restrict access to sinks or impede path of travel.

End of Section 10810

DIVISION 11 - EQUIPMENT

Section 11050 – Compact Shelving

Introduction

Compact shelving format is to be established during programming and design phases with the affected University Department and the Design Professional.

Part 1 - General

- Compact shelving may be manually or electrically operated.

Part 2 - Products

- If the compact shelving is electrically operated, then the following criteria should be requested:
 - All electrical wiring and equipment shall comply with the current NEC, class 1 circuit, Article 725.
 - The class 1 circuit limited power shall be from the fused control box to the wiring on the load side of the control box.
 - Flexible cords and cables will be allowed if the class 1 circuit is totally in compliance with Article 400 & 725 of the current NEC. This class 1 circuit shall not include wiring to the light fixtures on or associated with the compact shelving. Cords shall be rated for service encountered.
 - All wiring and equipment shall be grounded and bonded according to Article 250 or the applicable article of the current NEC.
 - All wiring methods shall be installed according to Article 300 of the current NEC.
 - All electrical devices, materials and equipment shall be listed and approved by a University of Arizona approved testing laboratory and shall be used for it's approved listing and it's intended purpose. Motors shall be suitable for duty encountered and the motor controls shall be readily accessible. Laboratory listing and component listing shall be a performed by U.L., C.S.A., F.M., City of Los Angeles or other laboratory approved by the University of Arizona.
 - Light fixtures shall be wired with M/C cable or other approved means. This cable shall be no larger than 3/8" in size.
 - Motor protection shall comply with current NEC, Article 430.
 - Light fixtures shall be approved for feed-through application on their listing label or shall be installed with a junction box external to the fixture to accommodate feeding the next fixture. Ballasts shall be Magnatec, Advanced or other University of Arizona approved manufacturer.
 - Fixture shall have CR85, T-8, 4100K lamps and shall meet the EPA requirement for non-hazardous disposal.
 - All penetrations for cords, cables or the like shall have an approved bushing installed wherever the wiring method passes through any metal enclosure, pipe, channel, light fixture, etc. This applies at all ends of hollow metal channels also.

Part 3 - Execution

- If the compact shelving is electrically generated then the following should be requested:
 - All compact shelving wiring shall be inspected and approved by University of Arizona Facilities Design & Construction Department Inspectors.
 - The compact shelving representative shall meet with University Representatives prior to installing any electrical wiring, devices, or equipment, to review any changes or variations in the applicable code or University of Arizona Standards.

End of Section 11050

DIVISION 11 - EQUIPMENT

Section 11132 - Projection Screens

Introduction

Verify information with the University Teaching Center

Ceiling mounting is preferred to clear wall mounted items. Mounting shall be secure and durable. "S" or "J" hooks shall be closed.

Lecture hall screens shall be electrically operated and laid out so that motor is accessible and fire ratings of ceiling and wall surfaces are not interrupted. 110V switch is provided for operation at a wall location and 24V switch is required for operation at a lecturn.

Manual pull down screens shall be not less than 8' wide.

Part 1 - General

- Reference Division 16 if the screens are electrically operated

Part 2 - Products

- Front view projection screens shall be a matte white polyester viewing surface with 1.2 grain characteristics complying with FS GG-S-00172D(1) for type A screen surface. Screens shall be seamless construction, mildew resistant and comply with NFPA 701 for fire performance characteristics.
- Where video projection is provided in the room, a "tab tension" shall be provided (to provide a uniform surface across the surface of the screen).

Part 3 - Execution

- There are no unique University requirements.

End of Section 11132

DIVISION 12 - FURNISHINGS

Section 12000 - General Discussion

Introduction

This General Discussion Section contains material which is important to the successful fabrication and/or installation of furnishings and equipment in construction projects. The issues are fundamental to the basic design of the project, and the long term success of those elements of the project., as well as the fabrication and installation process.

The consultant is expressly responsible for incorporating these overall requirements into the project, and for insuring that all the sub consultants are aware of the requirements and incorporate them into their designs as well.

Furniture

Items available through the Tri-University Purchasing Agreement are purchased by that means. Other items are bid through the Purchasing Dept. in compliance with the University Procurement Code. Furnishings are not usually a part of the building construction contract.

End of Section 12000

DIVISION 12 - FURNISHINGS

Section 12345 - Laboratory Casework

Introduction

These Standards differentiate between Laboratory Casework and Architectural Woodwork / Custom Casework because of the specialized nature and use of the product. Architectural Woodwork / Custom Casework Shall be specified separately in **Division 6 Wood and Plastics**.

Because the University anticipates a longer than average building life and higher than average use and abuse, durable, high quality Laboratory Casework is essential to the long term success and serviceability of any project. Section 12000 - Laboratory Casework specifies current Standards of the American Woodworking Institute (AWI) but modifies the standard to omit the use of certain materials in certain conditions and in certain portions of the work. Although used extensively industry wide, in the experience of the University, these materials have proven unsatisfactory and must be specifically excluded from the specifications. Specific pre-approved fabricators and/or manufacturers are listed, who, in the experience of the University, provide the necessary quality of work. Other fabricators/ manufacturers may be used through the pre-approval process.

Part 1 - General

- Laboratory Casework shall be fabricated to current standards of the American Woodworking Institute (AWI) and within the guidelines of the Scientific Apparatus Manufacturers Association (SAMA). Specific project requirements will determine the need for acid and chemical resistant acrylic, chemical resistant solid phenolic plastic, acid resistant plastic laminate, or standard plastic laminate counter tops.
- Indicate requirements for utility provisions which must be coordinated by the fabricator.
- Reference appropriate sections for Laboratory Tops and Equipment. (See Tab C3 Laboratory Planning and Design Criteria.)

Part 2 - Products

- All Laboratory Casework shall be "Custom" grade according to the American Woodwork Institute (AWI) and subject to the following:
- No particle board or particle board core plywood may be used in any part of the work (including laminate tops) and shall be specifically excluded. Plywood shall be industrial quality.
- Casework shall be opaque or transparent finish rotary cut uniform color light birch hardwood (unless otherwise approved by the Project Manager). Architect shall specify finish and call for sample submittal for review and approval. Interior of millwork shall receive opaque or transparent finish to match exterior.
- Pre-approved fabricators and manufacturers of **Laboratory Casework** are:
 - Atkinson's Cabinet Shop, (520) 792-4775
 - ISEC, Inc., (602) 926-1667
 - Carreto Custom Cabinet, (520) 624-3733
 - Sierra Woodworks, (520) 881-0222
 - Showcase Custom Cabinetry, Inc.,
 - Turnkey Corporation, (520) 571-8819
 - Creative Cabinets, (520) 624-3202
 - Collegedale, (423) 238-8113
- The lists in this section are non-exclusionary and not intended to be a comprehensive list of qualified fabricators and manufacturers. These lists are intended to identify Fabricators and manufacturers that have met the design and specification standards that are identified in this Section. Other fabricators and

manufacturers that can meet the design and specification standards in this Section may be considered.

- The pre-approved manufacturer of solid phenolic plastic lab tops is: **Pionite**.
- Minimum grades for plastic laminates shall be as follows (NEMA / ISO / Inch Thickness). For horizontal surfaces use HW62/HCS/.062" or GP50/HGS/.050" and for vertical surfaces use BK50/BGS/.050". Do not specify post forming grades of Laminates.
- Approved manufacturers of plastic laminate are:
 - Wilson Art
 - Formica
 - Nevamar
 - Pionite
- Hardware shall be indicated in a schedule in this section or in Section 08710, Finish Hardware. If in Section 08710, reference to that section.
- Drawer glides shall be full extension Heavy duty rated.
- Hinges shall be concealed type full metal with no plastic parts, 180° degree opening capacity.
- Hardware for adjustable shelves in cabinet bodies shall be K-V adjustable track with metal shelf support.
- Hardware for adjustable shelves on walls shall be heavy duty type equal to the K-V standard and bracket system.
- Approved hardware manufacturers are:
 - McKinney
 - K&V
 - Blum
 - Stanley
 - Gras

Part 3 - Execution

- Fabricate case bodies with stop dadoes if transparent finish.
- All "Custom" grade Casework concealed surfaces shall be treated at the shop with spray or brush application of 50% Pentachlorophenol solution in a 1:10 mixture with deodorized spray base. In the field all concealed scribed and cut surfaces shall receive a brush application of the same material.
- Drawers shall be lock shouldered or multiple dovetailed and have applied fronts. Bodies shall be hardwood or 7 ply plywood. Bottoms shall be hardwood panel product or masonite hardboard full or stop dadoed. Exposed surfaces shall be hardwood. All drawers shall ride on full extension, full suspension drawer glides.
- Plastic laminate application shall be specified as follows:
 - Apply side edging first, then top surface, with top surface overlapping side edging.
- Installations shall be by skilled tradesmen. In the cases where fabricator and installer are not one and the same, product and project guarantee shall not be compromised.

End of Section 12345

DIVISION 12 - FURNISHINGS

Section 12510 - Blinds

Introduction

Window blinds may be a part of the construction contract (preferable if there is no furniture contract) or a part of the FF&E budget. Check with the University Project Coordinator to see what method is appropriate.

Details should provide for proper attachment with backing as required for the attachment. If blinds will sit in front of windows, insure that they will clear furnishings. If blinds sit within window recess, make certain depth of recess is adequate for proper installation.

Vertical or horizontal blinds may be at the discretion of the Design Consultant. (Users occasionally have preferences.) Overall building appearance should be considered and if a standard has been established, that standard should be maintained so exterior appearance is consistent. Generally, vertical blinds do not retain dust and horizontal blinds do. Mini-blinds are preferred if horizontal and in either case, metal is preferred.

Specifically indicate on the plans the locations of the blinds.

Part 1 - General

- There are no unique University requirements.

Part 2 - Products

- There are no unique University requirements.

Part 3 - Execution

- There are no unique University requirements.

End of Section 12510

DIVISION 12 - FURNISHINGS

Section 12690 - Floor Mats and Frames

Introduction

Recessed floor mats must be provided at building entrances. Exterior installations are preferred.

Part 1 - General

- Require submittal of appropriate samples for approval and review of colors if applicable.

Part 2 - Products

- Frames shall be recessed and of aluminum, bronze, or other material complimentary to the building design.
- Metal foot grille type shall be specified. Size of panels shall be such that they are easily removed for cleaning. Joints shall divide the units into equal sections and material pattern in each section shall align with the adjacent sections.

Part 3 - Execution

- Comply with manufacturers instructions and coordinate top of mat surfaces with doors so that swing across mats provides under door clearance.

End of Section 12690

DIVISION 12 - FURNISHINGS

Section 12710 - Fixed Seating

Introduction

No discussion.

Part 1 - General

- Seating Layout: Design and install seating to optimize sight lines and space utilization. Comply with ADA Rules and Regulations. Architect shall provide initial layout and plans in a diagrammatic form showing number of seats, minimum aisle widths, H.C. seating spaces and armrest locations, aisle lighting and other requirements.
- Specify single-source responsibilities. Obtain seating, accessories, mounting components, including installation and coordination responsibilities from a single manufacturer.

Part 2 - Products

- Lecture Hall and Auditorium Seating:
 - Floor mounted fully padded, fabric covered seats with molded plastic backs and heavy gauge steel seat frame and pan. Provide self rising mechanisms. Do not use rail mounted systems.
 - Lecture Hall seating shall have folding tablet arms with nominal plastic laminate writing surface on hardwood plywood core, with rounded edges. Provide 13% of tablet arms for left-handers located on aisle seats.
- Arena Seating:
 - Riser mounted molded plastic with and without fabric covered padded seats (as required by the building program). Standards shall be cast iron.
- All seats shall be provided with Manufacturer's standard number and letter plates after determining seat/row designations with the University.
- Acceptable Manufacturers:
 - American Seating Col.
 - Hussey Mfg. Co.
 - Irwin

Part 3 - Execution

- Comply with recommendations of seating manufacturer for secure and proper installation.
- Install chairs using manufacturer's recommended hardware and fasteners. Chairs in curved rows shall be installed at smooth radius.
- Mounting bolts and assembly hardware shall be cut, capped and/or otherwise finished to achieve both a finished appearance to the installation and eliminate protrusions and sharp edges which could cut and tear.

End of Section 12710

DIVISION 14 - CONVEYING SYSTEMS

Section 14000 - General Discussion

Introduction

The size, number, and location of elevators must be addressed at the earliest stages of the design, to ensure that neither the overall function of the facility nor the optimum configuration of elevators is compromised. The size and location of the machine room is similarly critical.

Provide a minimum elevator machine room size of 100 square feet, exclusive of the area above the hoistway (for traction elevators), and without any odd corners, narrow passages or structural interferences.

Consultant shall design elevators to comply with current ASME A117.1, ASME A117.2, UBC and NEC codes.

When new elevators are being installed into existing buildings where elevators do not currently exist (as opposed to elevator modernization) comply with the criteria for new elevators to the most practical degree (extent) possible.

The Consultant is expressly responsible for incorporating these overall requirements into the project, and for ensuring that all sub-consultants are aware of the requirements and incorporate them into their designs as well.

Reliance on "after-the-fact" equipment selections to compensate for a problematic design decision is unacceptable.

Consultant is encouraged to develop the basic building design so that stairs are the naturally preferred mode of vertical travel.

Service elevators shall be located near the loading dock.

Basic Elevator Selection

Hydraulic elevators are generally used in low-rise buildings with two to three floors. Electric traction elevators are generally used in buildings over three stories. Consultant shall coordinate the electrical requirements as well as the code requirements for the pit, overhead clearance, shaft ventilation, pit ladder, light (with switch adjacent to ladder) and electrical duplex 120 VAC outlet in pit, equipment room and phone in cab.

In addition to this general discussion section refer to the following applicable sections:

- Section 14210 – Electric Traction Elevators
- Section 14240 – Hydraulic Elevators
- Section 14440 – Stair Lifts
- Section 16175- Elevator Power and Controls

Fire Alarms and Protection

Do not install sprinklers in the elevator hoistways unless required by the applicable codes. These requirements would include 1) The hoistway of a freight elevator, 2) The hoistway of any elevator with a polyethylene coated or flammable belt material, 3) the hoistway of a hydraulic elevator containing a hydraulic fluid with a flashpoint below the limit established by UA Risk Management Services, 4) a hoistway of combustible construction or 5) the hoistway for a car not compliant with ASME A17.1 for car construction.

Smoke / heat detectors in the hoistways will only be required in association with required sprinklers as stated above and applied per NFPA 72 and ASME A 17.1. Supplemental heat detectors are required within 24 inches of each required sprinkler head for activation of a shunt trip circuit. The shunt trip circuit will shut off elevator equipment power prior to the discharge of water from the sprinkler system.

NFPA 13 & 72, ASME A 17.1 and the IBC will dictate the balance of sprinkler and initiating device application throughout the related elevator spaces.

University Checklist

The following checklist is used by the University when reviewing elevator drawings and specifications. The Consultant is encouraged to review this against his specifications to insure completeness at the time of submittal.

Motion Control Engineering Controls	Motion control performance
Modem and connections	ADA phone and make connections
Shunt trip breaker w/ heat detector	GFI breakers on 120 V. circuits, M/R and hoistway
Sump pump in elevator pit	Run phone wires for emergency phone and modem
Fire Service	Vent and cool M/R
Mount controller on M/R wall to prevent vibration	Lockable car light switch in M/R
Oil return pump	Submersible pump on hydraulic pump units
Pit depth	Duplex receptacle in pit
Pit stop switch next to ladder	Pit ladder
Sump pump in pit	Pit light switch next to ladder
Vent hoistway (unobstructed)	Hoist way overhead clearance
Paint fascia	PVC casing around jack assembly
Car control station shall be hinged and swing for easy access	Emergency light located in car control station
COP Maintenance panel key to (Northeast J200)	Car position indicator
Hall lanterns (directional arrows)	Hall position indicator at main lobby only
All fixtures illuminated by LED's	2-way voice emergency communication required for bldg. height > 60'
Stop switch keyed to EPCO-1	Tamper resistant fixtures by EPCO
Independent service keyed to EPCO-1	Meet ADA requirements (Braille & audible signals)
Smoke detectors to be compatible with and tie into building system	Light & fan switches keyed to EPCO-1
S.S. Handrails	Fire service switch keyed to AZFS
Squirrel cage fan single speed	Provide emergency access in all hall hoist way doors
Photo curtain (Gatekeeper 2000 by Adams)	Provide protective cab blankets & hooks
Instruct University	Engrave bldg name and elevator # in car control panel
As-built drawing, parts list, instructions (in triplicate)	GAL door equipment
Key lock out to be mortised and accept Sargent & Medico cylinders	Nudging
Self-closing self-latch machine room doors	Test equipment
	12 mo. warranty and maintenance w/24 hour coverage at no added cost
	Verify M/R access, slope ships ladder to be less than 60°
	Fire extinguisher in all machine rooms
	Elevator shutdown (shunt trip)
	Shunt trip control circuits monitored

- Ancillary electrical elevator equipment shall be fed from a separate, solely dedicated, elevator electrical LOAD CENTER. This elevator load center shall only be used for elevator related equipment and devices. It will provide the required means to lockout the equipment for service. Required characteristics of elevator electrical Load center are: surface mounted, copper bus, no door, dead front, 14 inches wide, lockable (lockout) breakers and a maximum size of 12 full size breaker spaces. Additional spaces are authorized only where the number of elevator related loads increases above 12 spaces. Unused breaker spaces shall not have any spare breakers installed. Ancillary elevator equipment to be fed from this panel may be, but is not limited to, the following:
 - Shunt trip control feed
 - Machine room lights/receptacles
 - Elevator car lights
 - Elevator pit lights/GFI receptacle
 - Elevator pit sump pump
 - Machine room A/C

- Elevator Fan (A/C)
- Hydraulic oil cooler
- Main electrical elevator feed should employ a molded case shunt trip breaker and a suitably sized enclosure. Larger enclosures for electronic type breakers are to be avoided as they take up too much room in an already cramped service space. Requirements for electrical coordination to be accomplished upstream of the main elevator feed.

Refer to attached pages 14000-4 through 14000-13 for “Construction Guidelines For Elevators”, “Firefighters Service/Shutdown Requirements” and “Inspection Requirements Checklist” presented by The Industrial Commission of Arizona.

ICA/ADOSH-ELEVATOR SECTION – PHOENIX (602) 542-3313 TUCSON (520) 320-4236, 37, or 48



CONSTRUCTION GUIDELINES FOR ELEVATORS

(Per ASME A17.1- 2007⁷ Elevator Safety Code and other applicable codes)



HOISTWAY / HOISTWAY MACHINERY SPACE / PIT

pg. 1 3-10

- 1) Sec. 2.1/2.7 - Provide hoistway enclosure conforming to all applicable codes. Fire-resistance ratings of hoistways and machinery spaces shall conform to the building code. Seal all gaps and penetrations.
- 2) Rule 2.1.1.2.2.(e) - Where applicable, hoistway glass shall be laminated and each piece visibly marked as per ANSI Z97.1 or 16 CFR Part 1201. Windows are prohibited in hoistways.
- 3) Rule 2.1.4 - Hoistway ventilation to the outer air shall be provided, per the building code, for elevators penetrating more than three floors. The area of the hoistway vent shall not be less than 3 ½ percent of the area of the hoistway nor less than 3 square feet for each elevator car.
- 4) Rule 2.1.6 - Projections, ledges, or recesses more than 4 inches shall be beveled not less than 75 degrees.
- 5) Sec. 2.2 - Pit floors shall be approximately level and be provided with a sump for a drain or sump pump and have a sump cover that is flush with the floor. Drains or sump pumps shall remove a minimum of 50 GPM per elevator. Exposed discharge lines shall be of metal. Discharge lines shall be provided with a check valve installed close to the drain or pump. Shut-off valves in discharge lines and oil sensing equipment to stop fluid removal are not allowed.
- 6) Rule 2.2.4 - Access to pits shall be by a ladder extending to at least 48 ins. above the lowest landing or by a separate pit access door, where required. Ladders shall be within reach from the lowest landing door.
- 7) Rule 2.2.5 - Pits shall be provided with a minimum of 10 foot candle lighting with light guard. The light switch shall be located on the pit ladder side and within easy reach from the pit access door.
- 8) Rule 2.2.8 - Where applicable, provide a permanent means to access the underside of the car (i.e.; working platform) if the distance from the pit floor to the underside of the plank channels or slings exceeds 83 inches.
- 9) Rule 2.7.3.4.3 - Where applicable, hoistway access doors of secondary and overhead machinery spaces shall be a minimum of 29 ½ inches in width and height and shall be self-closing and self-locking using a spring-type lock.
- 10) Rule 2.7.3.4.6 - Where applicable, hoistway access doors necessary for access to an MRL elevator emergency brake shall be a maximum of 24 inches in width and height and shall be self-closing and self-locking using a spring-type lock. Keys to unlock the access doors shall be Group 1 Security (restricted to elevator personnel only).
- 11) Rule 2.7.4 - Where applicable, headroom in secondary and overhead machinery spaces shall be a minimum of 42 inches without a governor and 53 inches with a governor.
- 12) Rule 2.8.3.3.4 - If sprinklered, all electrical equipment in the pit within 48 inches above the pit floor shall be weatherproof (NEMA 4 rated) and wiring identified for use in wet locations per NFPA 70.
- 13) Rule 2.4.12 - The minimum vertical distance in the refuge area between the car top and the overhead structure or other obstruction shall not be less than 43 in. when the car has reached maximum upward travel.
- 14) Rule 2.7.9.1 - Where applicable, hoistway machinery spaces shall be provided with a minimum of 19 foot candle lighting with light guard. The light switch shall be located within easy reach of access to such space.
- 15) Rule 2.7.9.2 - Where applicable, hoistway machinery spaces shall be provided with means, mechanical if necessary, to keep the temperature and humidity in the range specified by the elevator equipment manufacturer.
- 16) Rule 2.8.1&2 - Machinery and equipment or electrical equipment and wiring that does not pertain to the elevator is prohibited.
- 17) Rule 2.8.3.3 - Sprinkler protection shall supply only branch lines at not more than one floor level (see drawing). Sprinkler lines running up the hoistway are prohibited. Pit sprinkler heads shall be within 24 inches of the pit floor.
- 18) Rule 2.8.3.3.2 - When sprinklered, a main power shunt-trip disconnect and heat detector(s) is required. Heat detectors shall be within 2 feet of each sprinkler head at the top of the hoistway. No heat detectors in sprinklered pits.
- 19) Rule 2.8.3.4 - Pipes or ducts conveying gases, vapors, or liquids that do not pertain to the elevator are prohibited.
- 20) Rule 2.27.3.2.1 - Provide smoke detector(s) in the top of hoistways that are sprinklered.
- 21) NFPA 70 - 620.23 - Where applicable, secondary and overhead machinery spaces shall be provided with a GFCI protected duplex receptacle. Machinery space lighting (see #14) and receptacle shall be on a separate branch circuit.
- 22) NFPA 70 - 620.24 - Pits shall be provided with a GFCI protected duplex receptacle. A single non-GFCI receptacle shall be provided for the sump pump. Pit lighting and receptacles (see #7 and 12) shall be on a separate branch circuit.

MACHINE ROOM/ CONTROL ROOM/ CONTROL SPACE

pg.2 3-10

- 23) Sec. 2.7 - Provide machine room (control room/control space, if applicable) enclosure conforming to all applicable codes. Fire-resistance rating shall conform to the building code. Seal all gaps and penetrations.
- 24) Rule 2.7.2 - A minimum of 18 inches around equipment for maintenance path and clearance shall be provided.
- 25) Rule 2.7.3.1.1 - Safe, permanent, and unobstructed access to these rooms/spaces shall be provided.
- 26) Rule 2.7.3.3 - Stairs provided for access to or in machine/control rooms or control spaces shall be a minimum of 60 degrees from the horizontal, have handrails, and have a platform, at the access-door sill level. Platform length shall permit full swing of the door plus 2 feet for doors that swing out and platform length for doors that swing in shall be not less than the width of the door. Ships ladders are not acceptable as stairs. OSHA standards if applicable will apply.
- 27) Rule 2.7.3.4 - Access doors to machine rooms, control rooms, and control spaces shall be self-closing and self-locking using a spring-type lock. Doors to machine and control rooms shall be not less than 29 ½" wide and 80" high.
- 28) Rule 2.7.4 - Machine/control rooms shall have a clear headroom of not less than 84 inches. Control spaces, where applicable, shall have a clear headroom of not less than 78 inches or the height of the equipment, whichever is greater.
- 29) Rule 2.7.6 - Machine rooms and control rooms, where provided, shall not be located in the hoistway.
- 30) Rule 2.7.8 - Where applicable, remote machine rooms and / or control rooms of electric elevators shall be provided with a permanent means of communication between the elevator car and remote machine room and / or control room.
- 31) Rule 2.7.9.1 - Machine rooms, control rooms, and control spaces shall be provided with a minimum of 19 foot candle lighting (see #43) with light guard. Light switch shall be within reach from the door and on the lock-jamb side.
- 32) Rule 2.7.9.2 - Machine rooms, control rooms, and control spaces shall be provided with independent ventilation means to keep the air temperature and humidity in the range specified by the elevator equipment manufacturer.
- 33) Rule 2.8.1&2 - Machinery, equipment, electrical equipment, or wiring not pertaining to the elevator is prohibited.
- 34) Rule 2.8.3.3 - Sprinkler protection shall supply only branch lines into the machine/control room or control space.
- 35) Rule 2.8.3.3.2 - When sprinklered, a shunt-trip disconnect for the main power supply and heat detector(s) is required. Heat detector(s) shall be within 2 feet of each sprinkler head in the machine/control room or control space.
- 36) Rule 2.8.3.4 - Pipes or ducts conveying gases, vapors, or liquids that do not pertain to the elevator are prohibited.
- 37) Rule 2.8.3.5 - Pipes (i.e.; sprinkler) or similar equipment that contains liquid shall not be located directly above elevator or electrical equipment. Pipes shall not encroach upon any required clearances.
- 38) Rule 2.8.5 - Air conditioning equipment and condensate drains shall not be installed directly above elevator or electrical equipment. Condensate drain lines shall not be connected directly to sewers. Safe and convenient access for servicing and maintenance of air conditioning equipment shall be provided.
- 39) Rule 2.27.3.2.1 - Smoke detection shall be provided in machine/control rooms and control spaces for fire recall.
- 40) Rule 8.6.1.6.5 - A class "ABC" fire extinguisher shall be provided in machine/control rooms and control spaces.
- 41) NFPA 70-620.21 - All wiring shall be installed in metal conduit, box, or wireway.
- 42) NFPA 70-620.22 - A separate branch circuit shall supply the car lights.
- 43) NFPA 70-620.23 - A separate branch circuit shall supply the machine/control room or control space lighting and receptacle. A duplex GFCI receptacle in the machine/control room or control space shall be provided.
- 44) NFPA 70-620.25 - A separate branch circuit shall supply the machine/control room or control space air conditioning equipment. A disconnect with overcurrent protection and lockable in the open position shall be provided.
- 45) NFPA 70-620.51 - A single means of disconnect, with overcurrent protection and lockable in the open position, shall be provided for the main power supply (see #35). Per NFPA 70-620.91(c) - The main power disconnect shall be provided with an auxiliary contact for use on hydraulic elevators with battery lowering.
- 46) NFPA 70-620.51(d) - All disconnecting means shall be provided with identification and power feed locations.
- 47) NFPA 70-620.53 - A car light disconnect, with overcurrent protection and lockable in the open position, shall be provided in the machine/ control room or control space (see #42).
- 48) IBC-3006.6 - Plumbing systems (i.e.; floor drains) shall not be located in machine/control rooms or spaces.
- 49) NFPA 72-4.4.6 - Fire alarm annunciator panels shall not be installed in elevator machine/control rooms or spaces.

MISCELLANEOUS

- 50) Rule 2.27.1 - Where elevator rise is 60 feet or more, a two-way communications means within the building and accessible to emergency personnel to speak with persons in each elevator car individually shall be provided. Operating instructions shall be incorporated with or adjacent to the two-way communication means outside the elevator car.
- 51) Rule 2.27.3.2.1 - Smoke detectors shall be installed at each floor (lobby) served by the elevator. Heat detectors may be permitted where ambient conditions prohibit the use of a smoke detector (see drawing).
- 52) IBC-3002.4 - Buildings four or more stories above or below grade plane shall be provided with an elevator capable of transporting a 24" by 84" open ambulance stretcher and be identified on the hoistway door frame for such use.
- 53) IBC-3003.1 - In buildings or structures where standby power is required (i.e.; 75 feet of rise or more) or provided for elevator(s), all electrical circuits required for elevator(s) shall be connected to the standby power source.

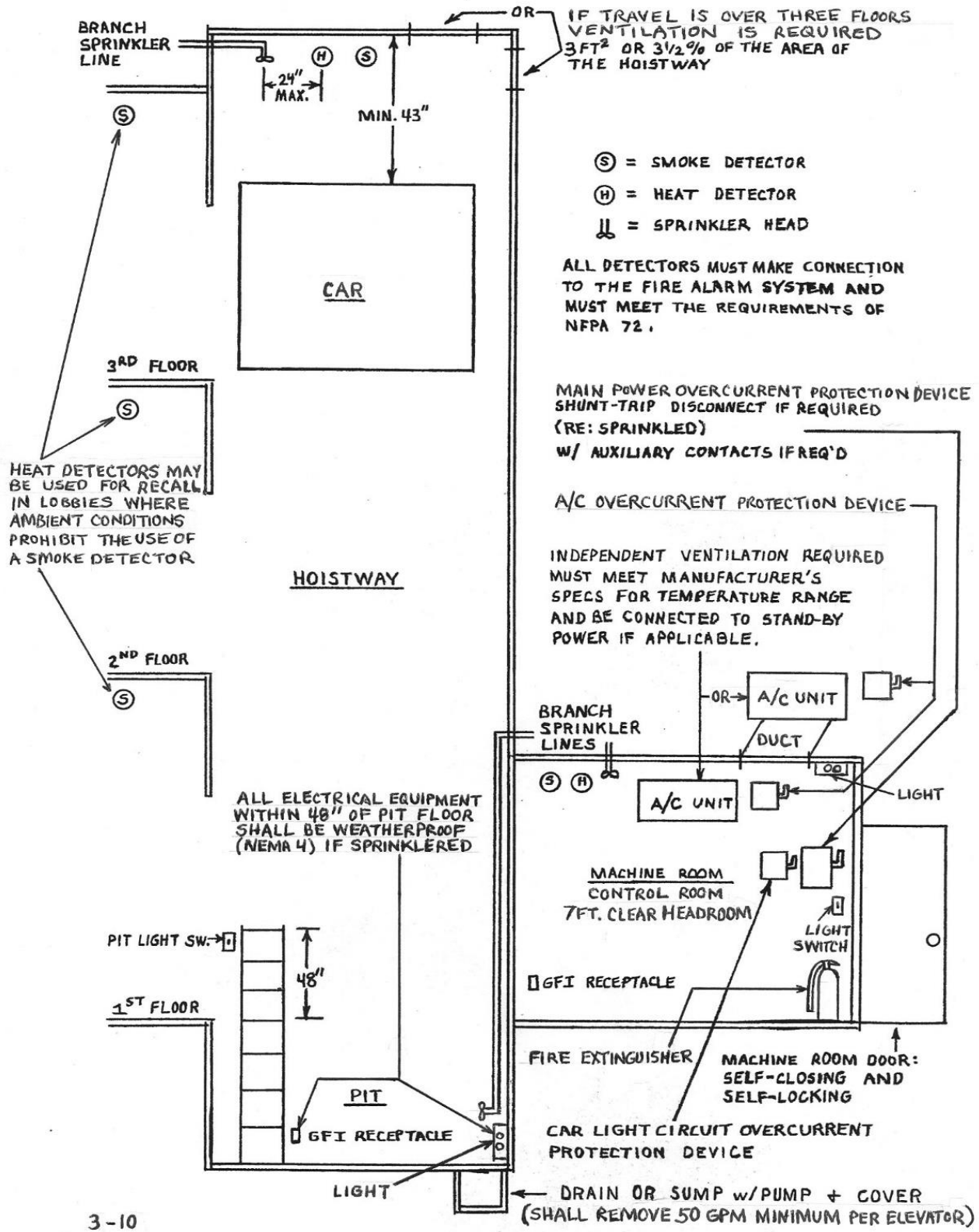

3-10

ICA/ADOSH-ELEVATOR SECTION – PHOENIX (602) 542-3313, TUCSON (520) 320-4236,4237



ELEVATOR SECTION
FIREFIIGHTERS' SERVICE / ELEVATOR SHUTDOWN
GENERAL REQUIREMENTS

(Per ASME A17.1-2000' and NFPA 72-current edition)

General Note:

The following requirements are only a guideline for Firefighters' Service ("elevator recall") and Elevator Shutdown. See the above listed code books for complete requirements. These two operations are separate and work independently of each other. Smoke detectors are used to "recall" an elevator for Firefighters' Service (takes it out of normal service) and heat detectors are used for Elevator Shutdown (main power removal) via the "Shunt-Trip" disconnect.

(A) Fire Alarm Panel requirements:

- 1) The Fire Alarm Panel shall not be located in the elevator machine room.
- 2) The Fire Alarm Panel, or where required - "remote annunciator-fire alarm panel", must be located in an area where an alarm will be readily noticed. If that is not possible, the Fire Alarm Panel, wherever its building location, must be remotely monitored.
- 3) The Fire Alarm Panel and when required - "remote annunciator-fire alarm panel" must identify the type of device activated and its location. Example: "smoke detector - top of elevator shaft (hoistway)"

(B) Detector requirements with no sprinklers in the hoistway or machine room:

- 1) A smoke detector is required in the elevator machine room. Activation of this device shall recall the elevator to the alternate floor, unless the machine room is remotely located, and must cause the "Fire Hat" light in the elevator car station to flash.
- 2) Smoke detectors are required in all enclosed (not open to the outside) elevator lobbies. The detector at the designated (egress) floor level must recall the elevator to the alternate floor and all other lobby detectors must recall the elevator to the designated level.
- 3) No detectors are allowed in the hoistway.

(C) Detector and other requirements with sprinkler in the machine room:

Same requirements as **(B) plus:**

- 1) Heat detector(s) required and shall be located within 24 inches of each sprinkler head. Heat detector(s), when activated, must "Shunt-Trip" the mainline disconnect before the activation of the any sprinkler head.
- 2) If at any time, the power source to operate "Shunt-Trip" is not present, the Fire Alarm Panel and required annunciator panels must indicate a supervisory signal for "loss of elevator shunt-trip power".
- 3) If the mainline disconnect in the machine room is manually turned "off" or its been Shunt-Tripped "off" from a heat detector activation, the Fire Alarm Panel must **NOT** indicate a supervisory signal for "loss of elevator shunt-trip power".

(1)

9-05

cont'd

(D) Detector and other requirements with sprinkler at the top of the hoistway:

Same requirements as **(B)** number 1) and 2) plus:

- 1) A smoke detector is required at the top of the hoistway. Activation of this device shall recall the elevator to the designated level and must cause the "Fire Hat" light in the elevator car station to flash.
- 2) A heat detector is required at the top of the hoistway within 24 inches of the sprinkler head. Activation of this device must "Shunt-Trip" the mainline disconnect prior to the activation of the sprinkler head.
- 3) All electrical equipment within 48 inches of the pit floor must be weatherproof and NEMA 4 rated (must provide protection from the water spray of a sprinkler head).

(E) Detector and other requirements with sprinkler at the bottom of the hoistway:

Same requirements as **(B)** number 1) and 2) plus:

- 1) A smoke detector is required at the top of the hoistway. Activation of this device shall recall the elevator to the designated level and must cause the "Fire Hat" light in the elevator car station to flash.
- 2) A heat detector is not required in the pit within 24 inches of the sprinkler head **if** the sprinkler head can be located within 24 inches of the pit floor. If the sprinkler head is over 24 inches above the pit floor, a heat detector will be required, and must meet the weatherproof NEMA 4 rating.
- 3) All electrical equipment within 48 inches of the pit floor must be weatherproof and NEMA 4 rated (must provide protection from the water spray of a sprinkler head).
- 4) A smoke detector is not advisable in the elevator pit (possibility for false alarms).

(F) Firefighters' Service Indication requirements:

- 1) Upon activation of any smoke detectors in any affected elevator spaces, or when the affected elevator Phase I Fire Service recall key switch is turned to the "on" position, an indicator light, on or at, the Phase I Fire Service recall key switch located at the designated level shall illuminate to indicate that the affected elevator(s) is on Firefighters' Service. Activation of any affected elevator lobby smoke detector shall illuminate the "Fire Hat" symbol located inside the elevator. Activation from a hoistway or machine room smoke detector shall illuminate a "flashing Fire Hat" symbol inside the elevator.

(G) Hydraulic Elevator Auxiliary (battery) Lowering with a Shunt-Trip disconnect req's:

- 1) An auxiliary contact on the mainline disconnect must be provided to disable the battery lowering function (elevator cannot move) if the mainline disconnect is manually turned "off" or if it has shunt-tripped "off". Battery lowering can only occur if the normal building power that feeds the mainline disconnect is not present.

(H) Sprinkler Line general requirements:

- 1) Only branch sprinkler lines are allowed in elevator spaces. Branch lines must terminate once they enter a space. Branch sprinkler lines entering the hoistway must enter only from the floor they are to serve. A branch sprinkler line that enters the hoistway at the first landing to sprinkle the pit, can only sprinkle the pit. The branch sprinkler line for the pit cannot extend up to sprinkle the top of the hoistway. That branch line must enter at the top landing. Branch sprinkler lines entering the hoistway at the top floor to sprinkle the top of the hoistway may not extend to other parts of the building. A branch sprinkler line entering the machine room shall only sprinkle the machine room, or it can be allowed to extend to the hoistway only if it will branch sprinkle at that level.

9-05

(2)

THE INDUSTRIAL COMMISSION OF ARIZONA
DIVISION OF OCCUPATIONAL SAFETY & HEALTH
ELEVATOR SECTION
P.O. BOX 19070
PHOENIX, ARIZONA 85005-9070

**REQUIREMENTS FOR ELEVATOR COMPANIES PRIOR TO CALLING
TO CONFIRM ACCEPTANCE INSPECTION**

MACHINE ROOM

Check Box When Completed

- 1) (IBC) Machine room fire rating must match hoistway fire rating
- 2) (IBC) Machine room door fire rating must match hoistway door fire rating
- 3) (A17.1) Machine room door must have the proper lock set and must self close
- 4) (IBC) Penetrations are to be sealed.
- 5) (NFPA & A17.1) An ABC fire extinguisher must be provided
- 6) (A17.1) No foreign electrical conduits may be run through the machine room
- 7) (A17.1) No plumbing allowed other than that required for the machine room A/C unit
- 8) (A17.1) No access panels in the ceiling or roof access hatches are allowed.
- 9) (A17.1) Overhead clearance 7' minimum
- 10) (NFPA) Smoke detector required. Heat detector required within 24" of each sprinkler head
- 11) (A17.1) Shunt trip breaker required if machine room or top of hoistway has a sprinkler
- 12) (A17.1) Shunt breaker must have an auxiliary contact to disable battery lowering, if provided, when the disconnect is either shunted off or turned off.
- 13) (NFPA) Shunt power must be monitored for power loss
- 14) (A17.1 & NFPA) All fire recall and shunt trip devices must be pre tested and panel labels checked for proper description.
- 15) (A17.1) Fire alarm panel is not allowed in the machine room
- 16) (NFPA) If fire alarm panel is not located in an area of general activity a remote annunciator must be in an area of general activity or the panel must have off site monitoring.
- 17) (NFPA) Off site monitoring of fire alarm devices must receive the device identification ie: 'machine room smoke detector Elevator #4'
- 18) (A17.1) PVC conduit or pipe is not allowed in the machine room
- 19) (A17.1) Code data tag required ie: 'built under ASME A17.1-2000 Code'
- 20) (A17.1) Temperature and humidity data tag required
- 21) (IBC) Independent ventilation required. Must not be connected to any other building supply or return.
- 22) (NEC) Machine room ventilation air handler must have a lockable disconnect switch and be on a dedicated circuit.
- 23) (NEC) Machine room lighting and GFCI receptacle must be on a dedicated circuit. Test for circuit separation before inspection.
- 24) (NEC) Car lighting circuit must have a current interrupting, lockable, externally operable disconnect switch.
- 25) (NEC) Car light circuit must be on a dedicated breaker. Test for circuit separation before inspection.

Your signature is necessary to serve as evidence of completion:

NAME _____ TITLE _____ DATE _____

JOB NAME _____

ADDRESS _____

Check Box When Completed

- 26) (NEC) All disconnect switches must have permanent labels noting device being disconnected and panel /breaker number for their power source. Breaker panels must have circuits identified.
- 27) (NEC) Proper electrical clearances per NFPA 70 must be verified. Low voltage (151 VAC on any leg to ground) to any grounded object must have 36” clearance. High voltage (over 151 VAC to ground) must have 42” clearance.
- 28) (NEC) Any Hot device to Hot device must have 48” clearance.
- 29) (A17.1) Emergency brakes (ie: rope grippers, sheave jammers), must be pre tested for empty car up direction unintended motion, 125% full load down direction unintended motion and empty car up direction over speed to insure that they will work correctly during the acceptance inspection.
- 30) (A17.1) Car safeties must be pre tested with rated load at governor jaw trip speed to ensure that the car safeties will stop and hold the car with the correct slide for this overspeed test during during the acceptance inspection.
- 31) (A17.1) All equipment must be properly identified (#1, #2 etc.)
- 32) (A17.1) All machine guards must be in place.
- 33) (A17.1) If seismic is required, all required anchors, rope retainers etc. must be in place.

PIT

- 1) (A17.1) Pit ladder must extend to 48” above the landing with handhold across the top. Pit ladder must be within 39” on a horizontal plane of the hoistway door release mechanism. Pit light and pit switch must be on the side that the ladder is on and be within easy reach from the hoistway entrance.
- 2) (A17.1) Second pit switch is required if the pit is over 67” deep.
- 3) (NEC) Pit light and GFCI receptacle must be on a dedicated circuit. Test for circuit separation before inspection.
- 4) (NEC) Duplex GFCI receptacle must be provided.
- 5) (NEC) Simplex non GFCI receptacle for the sump pump must be provided. This may be on the pit light/receptacle dedicated circuit or on it’s own dedicated circuit. Test to ensure that it is not fed from the load side of the pit GFCI if on the same circuit.
- 6) (NEC & A17.1) If the hoistway is sprinkled , than all electrical conduits, boxes etc. must be NEMA 4 rated within 48” of the pit floor. Sump pump receptacle must have a cover that allows the cord to be plugged in and the cover closed.
- 7) (NFPA) If the pit has a sprinkler that is within 24” of the pit floor no fire alarm device is required in the pit.
- 8) (A17.1) A sump pump with a cover flush with the pit floor is required. The cover must be substantial enough to support a person’s weight. Backflow prevention is required. A shutoff valve is not allowed in the discharge line. In lieu of a sump pump, a drain with backflow prevention is allowed.
- 9) (A17.1) The pit sump pump must be tested to ensure that it will keep up with the flow of water from a ¾” hose.
- 10) (AHJ) No PVC conduit or piping is allowed in the pit.

Your signature is necessary to serve as evidence of completion:		
NAME _____	TITLE _____	DATE _____
JOB NAME _____		
ADDRESS _____		

Check Box When Completed

- 11) (A17.1) No oil sensors /separators are allowed in the elevator pit to prevent the sump pump from activating.
- 12) ***** As a courtesy to the building owner, if an oil separator is provided outside the pit have the contractor check that the separator is sized at least as large as the sump pump discharge capacity.
- 13) (A17.1) Pit lighting must be a minimum of 10 foot candles at all points of the pit floor.
- 14) (A17.1) Counterweight guards if required must extend from the lowest part of the counterweight when it is resting on it's fully compressed buffer to a point not less than 83" and not more than 96" above the pit floor.
- 15) (A17.1) Counterweight guards must be permanently labeled with the designed minimum counterweight runby.
- 16) (A17.1) If seismic is required, hydraulic over speed rupture valves must be provided on hydraulic elevators, properly located and pre tested.
- 17) (A17.1) If seismic is required provide required hydraulic feed line support spacing.
- 18) (A17.1) For a hydraulic elevator, verify that when the elevator is resting on it's fully compressed buffer that the hydraulic piston still has over travel available.
- 19) (A17.1) All hydraulic oil collection containers must be in place and all covers must be installed.
- 20) (A17.1) All hydraulic piston to platen head retainer bolts must be safety wired.
- 21) (IBC) Any conduit or pipe penetrations must be sealed.
- 22) (A17.1) Bottom floor hoistway access key switch if required must be pre tested. The bottom of the car platform apron should be level with the bottom of the hoistway door head jamb when the car is on the access upper limit.

HOISTWAY

- 1) (IBC) Venting required if over three floors. Verify that vent is equal to at least 3 ½ % of the area of the hoistway or 3 square feet, whichever is larger.
- 2) (IBC) All penetrations are to be sealed.
- 3) (IBC) All hoistway doors are to be sealed around door jambs and headers.
- 4) (A17.1) All ledges over 4" are to be beveled
- 5) (A17.1) No foreign piping or wiring is allowed in the hoistway.
- 6) (A17.1) Electrical feeders may not be run through the hoistway.
- 7) (A17.1) Fire alarm device wiring and conduits may not be run through the hoistway except to devices in the hoistway.
- 8) (NFPA) If the hoistway is sprinkled a smoke detector is required at the top of the hoistway. If sprinkled at the top a heat detector is required within 24" of the sprinkler head.
- 9) (NFPA) If the hoistway has beam pockets over 12" deep a smoke detector if required must be on the ceiling in each beam pocket.
- 10) (NFPA) Sprinklers if required must penetrate the hoistway only at the floor being sprinkled.
- 11) Sprinklers must only branch into the hoistway. They cannot then go out to another place in the building.

Your signature is necessary to serve as evidence of completion:		
NAME _____	TITLE _____	DATE _____
JOB NAME _____		
ADDRESS _____		

Check Box When Completed

- 12) (A17.1) All hoistway door retainers must be in place.
- 12) (A17.1) All hoistway doors must be numbered.
- 13) (A17.1) If seismic is required, all safety retaining devices and counterweight displacement devices must be installed and tested.
- 14) (A17.1) If elevator is the MRL type, a work light with bulb protection, a light switch on a dedicated circuit, and a stop switch must be provide in the vicinity of the drive machine.
- 15) (A17.1) If elevator is the MRL type and an access panel is provide for the brake release mechanism, this panel must have a self closing and self locking door with Group 2 security, a light switch for the work light located in the vicinity of the drive machine and have expanded metal on the inside of the hoistway to prevent reaching into the hoistway through this panel.
- 16) (A17.1) Top floor access switches must be provide if the distance from the top landing to the top of the car is over 35” when the car is level with the landing directly below the top landing.
- 17) (A17.1) Temperature and humidity data tags shall be provided on equipment located in the hoistway for MRL elevators.
- 18) (A17.1) Means to maintain manufacturer’s recommended temperature and humidity in the hoistway of MRL elevators shall be provided and it must be independent of other building supplies and returns.
- 19) (A17.1) Terminal limit switches must be pre tested to ensure they operate properly and are properly located.
- 20) (A17.1) Glass in hoistways shall meet the requirements of ANSI Z97.1 or CFR Part 1201 and must be laminated. Each piece must be permanently and legibly marked (ie:, ANSI Z97.1, CFR Part 1201 Laminated)

CAR (all items on this page A17.1)

- 1) Cartop railing must be installed if clearance to the hoistway exceeds 12”
- 2) Cartop work lights must have bulb protection.
- 3) Emergency exit must be locked and electrical contact working.
- 4) Door operator closing speed data tags must be provided and completed.
- 5) Hoist and governor data tags must be installed and completed.
- 6) Hoist rope anti rotation devices must be installed.
- 7) Telephones must be working properly.
- 8) Alarm and emergency lighting must be working.
- 9) Car flooring must be installed to eliminate a tripping hazard.
- 10) Car door closing speed must be within the parameters set by the door operator data tag.
- 11) Ceiling panels must be in place.
- 12) Capacity plates must be installed.
- 13) Car and counterweight safety data plates must be installed.
- 14) Car door restrictor devices must be working.
- 15) Car enclosures constructed of glass panels must be laminated and meet the requirements of CFR Part 1201, Sections 1201.1 and 1202. Each panel must be permanently and legibly marked (ie: CFR Part 1201, Section 1201.1, 1202 Laminated)

Your signature is necessary to serve as evidence of completion:

NAME _____ TITLE _____ DATE _____ JOB NAME _____ ADDRESS _____

Check Box When Completed

- 16) Glass used for lining cab walls or ceilings shall be laminated or may be tempered glass provided that it conforms to ANSI Z97.1, 16 CFR Part 1201, Sections 1201.1 and 1201.2. and the glass is bonded to a nonpolymeric coating, sheeting, or film backing having a physical integrity to hold the fragments when the glass breaks and the glass is tested and conforms to the acceptance criteria for laminated glass as specified in ANSI Z 97.1, or CFR Part 1201, section 1201.4. Each piece shall be permanently and legibly marked, (ie., ANSI Z97.1, CFR Part 1201, Sections 1201.1 and 1202 Tempered).

GENERAL REQUIREMENTS

- 1) Lobby flooring must be flush with hoistway sills to eliminate trip hazards.
- 2) Standby power if supplied to a common car group must have all cars in that group supplied with standby power.
- 3) If all elevators in a group supplied with standby power cannot be run simultaneously than a selection switch must be provided in sight of the elevator group at the designated level.
- 4) Standby power selection switches must be keyed the same as fire service (AZFS)
- 5) If all elevators in a group can be run on standby power, than the standby power source must be tested with all elevators running at the same time with rated load.
- 6) All lighting circuits, air conditioning circuits, etc. feeding the elevator must continue to be powered while on standby power.
- 7) Lobby ceilings must be in place with smoke detectors attached to the completed ceilings.
- 8) Flexible hydraulic lines may not penetrate a wall or be in the hoistway
- 9) All new technology ropes not meeting the prescriptive code must have rope maintenance guidelines on the jobsite and must remain in the machine or control room.
- 10) Written guidelines for the performance of all required Acceptance and Periodic tests must be maintained in the machine room or control room.
- 11) Multiple elevators in a building must be identified at the designated level and inside each elevator.
- 12) Fire service key switches must be AZFS

Your signature is necessary to serve as evidence of completion:

NAME _____ TITLE _____ DATE _____
JOB NAME _____
ADDRESS _____

ANY OF THESE ITEMS FOUND NOT TO HAVE BEEN CHECKED PRIOR TO CONFIRMING A SCHEDULED ACCEPTANCE INSPECTION IS CAUSE FOR THE INSPECTOR TO LEAVE THE JOBSITE AND A REINSPECTION TO HAVE TO BE SCHEDULED.

ALL OF THESE ITEMS MUST BE CONFIRMED TO BE COMPLETED PRIOR TO CALLING TO CONFIRM THE INSPECTION.

FAX OR E-MAIL THIS COMPLETED FORM TO OUR OFFICE AS PART OF THE CONFIRMATION PROCESS

Phoenix:
(602) 542-3313 (main #)
(602) 642-1642 (fax #)
ksturtevant@ica.state.az.us
j.sargent@ica.state.az.us
TStoltz@ica.state.az.us

Tucson:
(520) 325-3192 (fax #)
Respective Inspector:
Don Jimenez: (520) 320-4237 / (520) 404-9266 / DJimenez@ica.state.az.us
Bill Eley: (520) 320-4247 / (520) 404-9267 / welev@ica.state.az.us
Galen Williams: (520) 320-4248 / (520) 870-7739 / GWilliams@ica.state.az.us

DIVISION 14 - CONVEYING SYSTEMS

Section 14210 - Electric Traction Elevators

WORK INCLUDED

- Installation of a new engineered TRACTION elevator complete as described in this standard.
- Elevator systems shall be engineered in accordance with the requirements within this document.

SUBMITTALS

- Submit bound operation and maintenance manuals for the new equipment (4 copies) with operating and maintenance instructions, parts listing, recommend parts inventory listing, purchase source, listing for critical component, emergency instructions, complete "as built" wiring and block diagrams including input signals, and diagnostic and/or trouble-shooting guide shall be furnished to the Owner.
- Submit a complete list of all items to be furnished and installed under this section. Included manufacturer's specifications, catalog cuts, and other data to demonstrate compliance with the specified requirements.
- Submit complete shop drawings for all work in this section, showing dimensions and locations of all items including supporting structure and clearances required.
- Manufacturer's recommended installation procedures which, when approved by the Owner, shall be the basis for inspecting and accepting or rejecting actual installation procedures used on the work.
- Submit two (2) complete clean set of drawing prints and specifications with "as-built" conditions marked in crisp red ink. Sign and attest to the documents as reflecting all conditions "as-built".
- Provide two (2) copies of Operation and Maintenance Manuals, Installation Manuals and Parts Manual necessary for full servicing of the elevator and microprocessor.
- Provide one (1) digital copies on "CD" of "AS-BUILT" wiring drawings and O& M Manuals.

QUALITY ASSURANCE

- Elevator installer is responsible for quality assurance and insuring that all systems related to the function of the elevator are complete and functioning properly.

MAINTENANCE

- Starting at the time of substantial completion of the complete project, provide complete systematic inspection and maintenance of the elevator for a period of 12 months. Furnish trained experts and equipment to check, adjust, lubricate, and otherwise maintain the elevator in operation with out defects or deterioration. Replace or repair materials and parts which become defective or deteriorated for any reason except through abuse or misuse by Owner.

USE OF ELEVATOR

- The elevator shall not be used temporarily for building construction purposes unless specifically allowed by the Owner.
- If the Contractor is allowed to use the elevator prior to Substantial Completion of the project, the warranty and service period shall not be comprised and shall begin when substantial completion is achieved.

ENGINEERED TRACTION ELEVATOR

- **Acceptable elevator manufacturers are:**
 - Kone Elevator Company
 - Otis Elevator Company
 - Schindler Elevator Company
 - Thyssen Krupp
 - Arizona Elevator Solutions

- **Attributes** (Traction Elevator)
 - Capacity: TBD
 - Speed: TBD
 - Operation: Selective collective.
 - Control: Microprocessor based Motion Control Engineering 4000 regenerative controller AC motor drive.
 - Travel: TBD
 - Stops: TBD
 - Openings: TBD
 - Platform size: TBD
 - Clear inside car: TBD
 - Car Doors: TBD
 - Hoist way entrance: TBD
 - Hoist way entrance finish: TBD
 - Door Operation: *G.A.L. MOVFR System*
 - Landing system with MCE ELGO Absolute Positioning System
 - Hollister-Whitney rope gripper
 - Safety plank type B
 - Hollister-Whitney Governor, tail sheave, and rope
 - Signals: Illuminated car and hall operating buttons, illuminated by light emitting diodes. Tamper Proof. SUVIVOR PLUS by Elevator Products Corporation. (EPCO)
 - Provide emergency access in all hoist way entrances.
 - Photo curtain shall be model A850G7 Gatekeeper 2000 by Adams Elevator Equipment Co.
 - Car telephone shall be model no. A936P3-2 as manufactured by Adams Elevator Co.
 - Two-way voice communication within the building for emergency personnel in elevators with a 60ft or more rise (RATH Microtech)
 - Capable of emergency power switching and operation

- Car Enclosure:
 - Control panel (hinged to swivel toward the wall for easy access) complete with the following:
 - Digital car position and direction indicator, illuminated with light emitting diodes.
 - Fan key switch (EPCO-1).
 - Emergency stop key switch (EPCO-1).
 - Independent service key switch (EPCO-1).
 - Inspection/access key switch (EPCO-2).
 - Fire-fighter service key switch (AZFS).
 - COP Maintenance panel key to (Northeast J200)
 - Alarm bell push type switch.
 - Engraved capacity plate and elevator designation. Verify fabrication.
 - Engrave “ INSPECTION CERTIFICATE ON FILE AT FACILITIES MANAGEMENT “
 - Light key switch (EPCO-1).
 - Emergency light located in car control panel.
 - Emergency light test button.

- The car platform shall be provided with vinyl composition tile flooring. Color as selected by Owner.
- All elevators that are subject to high material or equipment transport use or other extreme uses (i.e., heavy loading, wheeled carts, exterior opening) shall have aluminum diamond plate floors.
- For elevators that open to the exterior of a building the area surrounding the elevator entrance should be sufficiently sloped away from the entrance to prevent water from entering into the elevator hoistway.
- Suspended egg crate ceiling with baked enamel finish or aluminum frame.
- Lighting: Cool white T-8 fluorescent lighting.
- Handrails: Stainless Steel.
- Sill: Aluminum.
- Ventilation: Exhaust type, single speed squirrel cage, 300 CFM velocity exhaust Blower. Isolate blower from steel cab canopy with rubber grommets.
- Provide hooks and removable blanket for protection of cab interior.
- Transom: Stainless steel.
- For elevators with glass installed in the cab or hoistway each piece of glass shall be laminated glass conforming to ANSI Z97.1 or 16 CFR Part 1201 with respective markings on each piece of glass clearly and permanently visible after installation.
- Elevator shall have provisions for handicapped complying with the requirements of ANSI A117.1 and new ADAAG Guidelines.
- Furnish manufacturers standard 3 roller guide assemblies with spring tension and adjustable rollers. T-rails with all required mounting hardware required for mounting.

ENVIRONMENTAL CONSIDERATIONS

- Ambient temperature: 32 F to 104 F (0 C to 40 C).
- Humidity: not over 95% humidity.

OPERATION, EQUIPMENT AND FUNCTION

Controller: Solid State Motion Control Engineering 4000 regenerative controller AC Motor Drive for traction elevators.

- The elevator controller shall be microprocessor based and designed specifically for elevator applications. Elevator and drive logic shall be implemented independently of safety functions.
- Elevator logic shall be implemented on a single processor to facilitate tight coordination between subsystems and enhance reliability. The implementation shall utilize a real-time, multi-tasking operating system to allow the processor to simultaneously execute elevator control logic, drive control logic, operator interface logic, and communication support.
- The elevator controller shall provide the ability to access significant memory capacity for configuration parameter storage, event recording, real-time diagnostics, and program execution.
- The elevator controller shall have an independent safety system in order to implement safety features required by code. The safety system implementation shall utilize solid-state devices. No relays shall be used for safety logic. The safety subsystem shall incorporate a check redundant, dual-processor, dual-path, solid-state, ASME A17.1-2000 compliant implementation that meets CSA and CE standards.
- The elevator controller shall be configured and packaged in such a way that external “jumpers” cannot be used (intentionally or unintentionally) while the elevator is running in any passenger mode of operation. Nonpassenger modes of operation shall be provided, along with means to bypass safety functionality, to allow inspection testing and other setup and/or troubleshooting operations.

- The elevator control logic configuration shall be fully field programmable. Changes in number of floors, I/O configuration, drive setup, eligibility etc. shall not require the replacement/reprogramming of EEPROMs or other storage devices. Further, changes in the controller configuration shall be user adjustable in the field.
- The elevator controller shall have extensive diagnostic capability. A built-in LCD display or equivalent shall allow access to major user functions and diagnostic features. The display shall be a multi-character, multi-line type with associated keypad to allow users to enter information. The display shall show data and menus in readily understood character format. No numeric, hexadecimal, or binary codes are acceptable.
- Dedicated indicators shall be provided in a conspicuous location on the elevator controller to indicate important system statuses, such as when the safety string is closed, when the door locks are closed, when the elevator is on Inspection/Access, etc. In addition, other special or error conditions detected by the main processor or safety subsystem shall be displayed.
- The elevator controller shall support an interface for communication and interaction via a separate application program running on a Windows PC. This application shall communicate with the controller and allow the user to access controller configuration parameters, view real-time elevator status information, initiate and facilitate setup and adjustment procedures, and provide advanced troubleshooting capabilities. The PC application shall be designed specifically for elevator applications and shall graphically and dynamically display information from the controller.
- A PC application shall provide facilities to manage elevator controller configuration parameters. The user shall be able to manage and manipulate parameters including:
 - Retrieve from the elevator controller and view/edit
 - Retrieve from the elevator controller and save to a file on the PC
 - Retrieve from the PC, view/edit, and download to the elevator controller
 - Manage separate configurations for multiple elevator controllers
- The user shall be able to select specific groups or subsets of parameters to send or retrieve from the elevator controller.
- A PC application display shall provide motor field (where applicable), armature and brake voltages, armature current, intended and actual car speeds and hoist machine RPM. The PC diagnostics and adjustment display shall include online context-sensitive parameter descriptions and help information for fault troubleshooting.
- The controller shall maintain an event log that records noteworthy events or faults. They shall be displayed in chronological order and time stamped for analysis or review. Data displayed shall include the type of event or fault, the date and time it occurred, and the position of the car and status of various flags at the time of the occurrence. The event log shall be able to be saved and reviewed offline via the PC application.
- Communication between the elevator controller and the PC application shall be via a standard 100 base T TCP/IP network connection. The elevator controller shall be compatible with standard networking equipment (cables, hubs, switches and routers etc.).
- A PC application and elevator controller shall support remote connection via the internet (if available). The elevator controller shall support up to four simultaneous PC connections (remote and/or local). A mechanism shall be provided to prevent the unauthorized alteration of elevator configuration parameters.
- A controller test switch shall be provided. In the test position, this switch shall enable independent operation of the elevator, with the door open function deactivated, for purposes of adjustment and testing. The elevator shall not respond to hall calls and shall not interfere with any other car in a duplex or group installation.

- Switches for controller inspection, enable, and up and down shall be provided to place the elevator on Inspection operation and allow the user to move the car from the machine room. The cartop inspection switch shall render the controller inspection switch inoperative.
- The elevator control and safety functions shall be part of an integrated system designed for ease of use, with diagnostics and parameter adjustments accessible through a common user interface.
- The brake supply shall be capable of providing at least four independently adjustable values of output voltage in order to provide smooth lifting, holding and releveling. These values shall be adjusted via computer parameters. Manual adjustment of resistor values shall not be required.
- The elevator controller shall provide auto-tuning of the brake control values.
- The controller shall provide logic to detect a failure of brake voltage to properly decay and relax a picked brake to hold/cooling position.
- The brake control system shall include circuitry to detect insufficient brake current. This failure shall cause the elevator to be removed from service at the next stop and remain out of service until the condition is corrected.
- For gearless applications, the drive control system shall use an optimized speed profile in a dual-nested-loop feedback system based on car position and speed. A speed feedback device (tachometer or encoder) shall permit continuous comparison of motor speed with the calculated speed profile to provide accurate control of acceleration and deceleration—right up to and including the final stop, regardless of direction of travel or load in the car. Drive subsystem control parameters shall be digitally adjustable through software and shall be stored in non-volatile FLASH memory.
- For DC applications, the system shall include precise closed-loop motor field control. The system shall regulate motor field current throughout the range of operation via current feedback from the motor field. The system shall provide motor field current sensing which shall shut down the elevator if insufficient motor field current is detected.
- The system shall provide adaptive gain parameters for optimum control of elevator speed throughout its travel.
- The system shall use a device to establish car position to an accuracy of 0.1875" (4.76 mm) or better, using a quadrature signal operating over the entire length of the hoistway.
- The system shall use an automatic two-way leveling device to control the leveling of the car to within 0.25" (6.35 mm) or better above or below the landing sill. Overtravel, undertravel, or rope stretch shall be compensated for and the car brought level to the landing.
- A system for pre-torquing the hoist motor shall be made available to ensure consistently smooth starts. An electronic load sensor shall be required to implement the pre-torquing feature.
- Pre-start sequencing shall be provided to safely energize the machine prior to the doors closing on a departing elevator, thus consistently improving floor-to-floor travel times.
- Door pre-opening as the car approaches a landing shall be field adjustable to begin a maximum of six inches from level-at-floor position.

AC Motor Drive

- The control system shall utilize an AC motor drive.
- The AC motor drive shall be capable of producing full torque at zero speed and shall not require DC injection braking in order to control car deceleration.

- The drive shall be capable of controlling geared and gearless machines, induction and permanent magnet motors. The drive shall also work with different types of encoders such as incremental, sine/cosine, and Hiperface.
- The drive shall have built-in motor overload protection. External overload is not required.
- The drive shall have the capability of being adjusted or programmed to achieve the required motor voltage, current, and frequency to properly match the characteristics of the AC elevator hoist motor.
- The drive shall not create excessive audible noise from the elevator motor.
- The drive shall be heavy-duty, capable of delivering sufficient current required to accelerate the elevator to contract speed with rated load. The drive shall provide speed regulation appropriate to the motor type.
- For non-regenerative drives, means shall be provided to remove regenerated power from the drive DC power supply during dynamic braking. This power shall be dissipated in a resistor bank that is an integral part of the controller. Failure of the system to remove regenerated power shall cause the drive output to be removed from the hoist motor.
- A regenerative drive option (PowerBack) is available to return power to the AC line during dynamic braking. This system is very effective for higher horsepower (above 30HP) and gearless applications.
- A contactor shall be used to disconnect the hoist motor from the output of the drive unit each time the elevator stops. This contactor shall be monitored and the elevator shall not start again if the contactor has not returned to the de-energized position when the elevator stops.
- The controller shall provide stepless acceleration and deceleration and provide smooth operation at all speeds.
- For applications where the building power supply has a “Grounded Leg Delta” configuration, an isolation transformer should be used to minimize noise and prevent any damage to the drive during voltage fluctuations.

Monitoring

- A PC-based system monitoring application shall be available. At a minimum, monitoring shall be capable of providing system status, car location and travel direction, operating mode, door operation indication, dispatching ETAs, and security status.
- The monitoring system shall be capable of remotely registering car and hall calls and of configuring hall call and car call restrictions in support of building security. The system shall be capable of implementing security overrides if required.
- The monitoring system shall be capable of enabling Swing, Sabbath, and Auto-stop modes of operation on the group control and of acknowledging emergency alarm activity on any car in the group.
- The monitoring system shall be capable of selecting group mode of operation including, Balanced, Lobby Peak, Demand Down, Demand Up, and Auto-mode (dynamic mode selection by group controller) when Operating Mode Configuration 1 is active on the group.
- The monitoring system shall be capable of setting the group to Flood Operation mode when such mode is supported by the group control.
- The monitoring system shall be capable of initiating recall of any car in the group to a selected floor and of controlling door operation of that car at the selected floor.

Reporting

- A client/server based report collection and generation application shall be available. Based on historical data collected by the server, the report application shall provide, at a minimum, hall call performance, hall call analysis, traffic analysis, hall call log, car call log, event log, emergency log, maintenance log, and percent in service reports.
- Systems that require hook-up of external devices for trouble-shooting are not acceptable.
- Nudging: If the doors shall be prevented from closing for longer than a predetermined time, door nudging operation shall the doors to move at slow speed in the close direction and to be unresponsive to the photo curtain. A buzzer shall sound while nudging operation is active.
- Hall or car call registration and lamp acknowledgment shall be by means of a single wire per call besides the power busses. Systems that register the call with one wire and light the call acknowledgment lamp with a separate wire are not acceptable.
- Fireman's Phase I emergency recall operation, alternate level Phase I emergency recall operation, and Phase II emergency in-car operation shall be provided according to applicable local codes. Keyed (AZFS)
- Independent service operation shall be provided such that the actuation of a key switch in the car operating panel will cancel any existing car calls, and hold the doors open at the landing. The car will then respond only to car calls and will ignore hall calls. Car and hoist way doors will only close by constant pressure on car call buttons or a door close button until the car starts to move. While on independent service, hall arrival lanterns or jamb mounted arrival lanterns and gongs shall be inoperative. Keyed (EPCO-1)
- Simplex selective collective automatic operation shall be provided for all single car installations. Operation of one or more car or hall call buttons shall cause the car to start and run automatically provided the hoist way door interlocks and car door contacts are closed. The car shall stop at the first car or hall call set for the direction of travel. Stops shall be made in the order in which the car or hall calls set for the direction of travel are reached, irrespective of the order in which they were registered. If only hall calls are set for the opposite direction of travel exist ahead of the car, the car shall proceed to the most distant hall call, reverse direction, and start collecting the calls. For multiple car installations use duplex, triplex, etc.
- A test switch shall be provided. In the "test" position, this switch shall allow independent operation of the elevator without the door open function for purposes of adjustment or testing the elevator. The elevator shall not respond to hall calls shall not interfere with the other car in a duplex installation.
- A timer shall be provided to limit the amount of time a car is held at a floor due to a defective hall call or car call including stuck push-buttons. Call demand at another floor shall cause the car to eventually ignore the defective call and continue to provide service in the building.

Emergency Recall Operation

- Elevators shall be arranged to operate in accordance with ASME A 17.1 Rule 211.3. Provide Phase I emergency recall switch for each group of elevators. Locate key switch at 2nd floor or main egress landing.

Geared Machine

- Hollister-Whitney Basement or Overhead Traction Machine
- Provide new AC reversible type, foot mounted hoist motor particularity designed for elevator service with a high starting torque (minimum 200% of rated torque) and a low starting current.

- The motor and controller shall have sufficient horsepower to drive the elevator under full load conditions and operate at a minimum 200 starts per hour without overstressing motor.

Governor

- Provide new centrifugal governor that will operate the car safeties should the elevator exceed 120% of contract speed in the down direction. Provide governor with a new rope and

Governor Ropes

- Provide traction steel governor ropes of sufficient size and number to ensure proper traction qualities. Governor ropes provided for any car shall be from same factory production run and shall be suitably protected against rust and corrosion.
- Properly secure governor ropes at both ends.
- Provide dated rope installation tag at car end of governor ropes.

Unintended Motion

- Hollister-Whitney Rope gripper with engineered bracket.
- Provide new rope brake gripper designed to meet codes for unintended motion in either the upwards or downward direction of travel.

Safety Device

- Provide new flexible guide car safety devices mounted on underside of the platform. Perform the necessary test as required code upon the completion of the project.

Car and Counterweight Guides

- Provide roller guides and assemblies consisting of spring-loaded tired wheels of a durable, resilient material maintained in uniform contact with three-finished rail surfaces and operate on dry UN-lubricated rail surfaces. Use polyurethane or other roller tire material, which will not develop flat spots after standing idle for 24 hours under average conditions. Provide the maximum car roller guide diameter as possible, given the tight rails and bracket clearances. ELSCO 6" model B shall be provided for the car and ELSCO 3" Model D for the counterweight.
- Statically balance car and counterweight so that minimum amount of pressure is required to center the safety throat in the rails and provides for the best ride quality.

Door Equipment

- Heavy Duty *G.A.L. MOVFR Door Operating System* to include, G.A.L. door rollers, door hanger tracks(car and hall) door pick-up assemblies, gate switch, door lock's.
- Provide emergency access in all hoist way doors.
- All doors shall have 1-1/2 hr. label or other identification acceptable to governing authorities.
- Provide adjustable nylon guide (by Nylube or Adams Elevator Equip. Co.).
- Heavy-duty doors. Provide door skins on both sides of elevator doors.

Lobby Position Indicator

- Provide tamper resistant lobby position indicator on the ground level, illuminated by light emitting diodes. By Elevator Products Co. (EPCO)

Smoke Detectors

- Smoke and heat detectors shall be compatible and tie into building fire system. NOTE: Heat detectors for activation of shunt trip devices do not need to report to fire alarm system.

Hall Direction Indicator

- Up and down tamper resistant SURVIVOR PLUS as manufactured by Elevator Products Co. (EPCO). Direction indicators to be provided in the hall wall with a single chime or tone for up and double chime or tone for down direction and shall be illuminated by light emitting diode.

Photo Curtain

- Photo Curtain: An electric, passenger sensing device of the photo curtain shall project across the entrance to prevent the car and hoist way doors from closing if a passenger or object interrupts the curtain.
- Nudging: If the doors are prevented from closing for longer than a predetermined time, door nudging operation shall cause the doors to move at a slow speed in the closed direction and to be unresponsive to the photo curtain. A buzzer shall sound while nudging operation is occurring.

Car Operating Station

- Flush mounted operating panel shall be mounted in the car return panel and shall contain the devices required for the specified operation. The buttons and devices shall be of the easy readability type and the floor designation buttons shall become illuminated when pressed and shall stay illuminated until the floor call is answered. Provide continuous hinge on panel for easy access to internal components. Locate hinges on side of panel nearest wall of the elevator. The car operating shall contain the floor designations, and all the controls indicated.
 - Digital car position indicator, illuminated with light emitting diodes.
 - Fan key switch (EPCO-1)
 - Emergency stop key switch (EPCO-1).
 - Independent service key switch (EPCO-1).
 - Inspection/access key switch (EPCO-2)
 - Firefighter service key switch (AZFS)
 - COP Maintenance panel key to (Northeast J200)
 - Alarm bell push type switch.
 - Light key switch (EPCO-1).
 - Engrave capacity and elevator designation.
 - Engrave "INSPECTION CERTIFICATE ON FILE AT FACILITIES MANAGEMENT"
 - Emergency light.
 - Emergency light test button.

Elevator Shutdown

- Elevator power shall automatically shutdown prior to sprinkler activation. This is typically accomplished by the use of a shunt trip breaker activated by a heat detector.
- Heat detector to be located no more than 24" from any fire sprinkler head installed in elevator shaft or machine room.
- Heat detector should also report to fire alarm system.
- Conduit circuits to shut down elevator power shall be monitored and supervised by the Fire Alarm System.

EXECUTION

Telecommunication Link

- Install communication cable for controller modem not to exceed 24" from controller.

- Install communication cable for car phone not to exceed 24" from controller.

Adjust And Balance

- Make necessary adjustments of equipment to ensure elevator operates smoothly and accurately.

Protection

- Locate and protect movable equipment and controls in such a way that they can only be operated by authorized persons.

Inspections

- Obtain and pay for inspections and permits and make sure test are as required by regulations of authorities. Conduct all tests and inspections in the presence of the Owner.
- Final inspection shall be after all new equipment is installed and operating correctly.
- Inspect installation in accordance with ANSI-A17.2
- Deliver test certificates and permits to Owner.

Operation And Maintenance

- Instruct Owner's personnel in proper use, operations and daily maintenance of elevators.
- Training shall include operation of diagnostic microcomputer and servicing of elevator microprocessor.
- Make final check of each elevator operation, with Owner's personnel present and just prior to date of substantial completion. Determine that control systems and operating devices are functioning properly.
- Continuing Maintenance: Provide 1-year maintenance on elevators on an as-needed basis as part of standard 1-year warranty on new equipment and upgrades.
- Maintenance shall include systematic examination, adjustment and lubrication of new elevator equipment; replacement of seals, packing and valves to maintain required factor of safety; performance of maintenance work with out removing car during peak traffic periods and providing 24 hour emergency call back service during maintenance period, at on additional cost to Owner.
- Repair or replace electrical and mechanical parts of the new elevator equipment using only genuine standard parts produced by manufacturer of equipment concerned.
- Ensure that competent personnel handle maintenance service. Maintain and adequate stock of parts for replacement of emergency purposes, locally, and have qualified personnel available at such places to ensure the fulfillment of this service without unreasonable loss of time.

Cleaning

- Remove all trash and debris from site during elevator installation.
- Clean all elevator surfaces, removing all dirt, dust, spots, and scratches. Any damage shall be repaired or replaced as directed by Owner, at no cost to Owner.
- Prior to substantial completion, remove protection from finished or ornamental surfaces and clean and polish surfaces with due regard to type of material.
- Remove tools, equipment and surplus materials from site.

End of Section 14210

DIVISION 14 - CONVEYING SYSTEMS

Section 14240 - Hydraulic Elevators

WORK INCLUDED

- Installation of a new engineered HYDRAULIC elevator complete as described in this standard.
- Provide an engineered system in accordance with this document.

SUBMITTALS

- Submit bound operation and maintenance manuals for the new equipment (4 copies) with operating and maintenance instructions, parts listing, recommend parts inventory listing, purchase source, listing for critical component, emergency instructions, complete "as built" wiring and block diagrams including input signals, and diagnostic and/or trouble-shooting guide shall be furnished to the Owner.
- Submit a complete list of all items to be furnished and installed under this section. Included manufacturer's specifications, catalog cuts, and other data to demonstrate compliance with the specified requirements.
- Submit complete shop drawings for all work in this section, showing dimensions and locations of all items including supporting structure and clearances required.
- Manufacturer's recommended installation procedures which, when approved by the Owner, shall be the basis for inspecting and accepting or rejecting actual installation procedures used on the work.
- Submit two (2) complete clean set of drawing prints and specifications with "as-built" conditions marked in crisp red ink. Sign and attest to the documents as reflecting all conditions "as-built".
- Provide two (2) copies of Operation and Maintenance Manuals, Installation Manuals and Parts Manual necessary for full servicing of the elevator and microprocessor.
- Provide one (1) Digital copies on "CD" "AS-BUILT" wiring drawings and O & M Manuals.

QUALITY ASSURANCE

- Elevator installer is responsible for quality assurance and insuring that all systems related to the elevator are complete and functioning properly.

MAINTENANCE

- Starting at the time of substantial completion of the complete project, provide complete systematic inspection and maintenance of the elevator for a period of 12 months. Furnish trained experts and equipment to check, adjust, lubricate, and otherwise maintain the elevator in operation without defects or deterioration. Replace or repair materials and parts which become defective or deteriorated for any reason except through abuse or misuse by Owner.

USE OF ELEVATOR

- The elevator shall not be used temporarily for building construction purposes unless specifically allowed by the Owner.
- If the Contractor is allowed to use the elevator prior to Substantial Completion of the project, the warranty and service period shall not be compromised and shall begin when substantial completion is achieved.

ENGINEERED HYDRAULIC ELEVATOR

- **Acceptable elevator manufacturers are:**
 - Kone Elevator Company
 - Otis Elevator Company
 - Schindler Elevator Company
 - Thyssen Krupp
 - Arizona Elevator Solutions

- **Attributes** (Hydraulic Elevator):
 - Capacity: TBD
 - Speed: TBD
 - Operation: Selective Collective
 - Control: Microprocessor based, Motion Control Engineering 2000 Hydraulic controller.
 - Travel: TBD
 - Stops: TBD
 - Openings: TBD
 - Platform size: TBD
 - Clear inside car: TBD
 - Car Doors: TBD
 - Hoist way entrance: TBD
 - Hoist way entrance finish: TBD
 - Door Operation: G.A.L. MOVFR System
 - Signals: Illuminated car and hall operating buttons, illuminated by light emitting diodes.
 - Tamper Proof. SURVIVOR PLUS by Elevator Products Co. (EPCO)
 - Provide emergency access in all hoist way entrances.
 - Photo curtain shall be model A850G7 Gatekeeper 2000 by Adams Elevator Equipment Co.
 - Car telephone shall be model no. A936P3-2 as manufactured by Adams Elevator Co.
 - Car Enclosure
 - Control panel (hinged to swivel for easy access) complete with the following:
 - Digital car position and direction indicators, illuminated with light emitting diodes.
 - Fan key switch (EPCO-1).
 - Emergency stop key switch (EPCO-1).
 - Independent service key switch (EPCO-1).
 - Inspection/access key switch (EPCO-2).
 - Fire-fighter service key switch (AZFS).
 - COP Maintenance panel key to (Northeast J200)
 - Alarm bell push type switch.
 - Engraved capacity plate and elevator designation. Verify fabrication.
 - Engrave " INSPECTION CERTIFICATE ON FILE AT FACILITIES MANAGEMENT "
 - Light key switch (EPCO-1).
 - Emergency light located in car control panel.
 - Emergency light test button.
 - The car platform shall be provided with vinyl composition tile flooring. Color as selected by Owner.
 - All elevators that are subject to high material or equipment transport use or other extreme uses (i.e., heavy loading, wheeled carts, exterior opening) shall have aluminum diamond plate.
 - For elevators that open to the exterior of a building the area surrounding the elevator entrance should be sufficiently sloped away from the entrance to prevent water from entering into the elevator hoistway.
 - Suspended egg crate ceiling with baked enamel finish frame.

- Lighting: Cool white T8 fluorescent lighting.
 - Handrails: Stainless Steel.
 - Sill: Aluminum.
 - Ventilation: Exhaust type, single speed squirrel cage, 300 CFM velocity exhaust blower. Isolate blower from steel cab canopy with rubber grommets.
 - Provide hooks and removable blanket for protection of cab interior.
 - Transom: Stainless Steel.
 - For elevators with glass installed in the cab or hoistway each piece of glass shall be laminated glass conforming to ANSI Z97.1 or 16 CFR Part 1201 with respective markings on each piece of glass clearly and permanently visible after installation.
- Elevator shall have provisions for handicapped and complying with the requirements of ANSI A117.1 and ADAAG Guidelines.
 - Furnish manufacturers standard 3 roller guide assemblies with spring tension and adjustable rollers. T-rails with all required mounting hardware required for mounting.

ENVIRONMENTAL CONSIDERATIONS

- Ambient temperature: 32 F to 104 F (0 C to 40 C).
- Humidity: not over 95% humidity.
- Vent machine room to outside to remove hydraulic fluid odors from building.

OPERATION, EQUIPMENT AND FUNCTION

- **Controller:** Solid State Motion Control Engineering 2000 controller for hydraulic elevators. Provide upgrade controller to be fully compatible with Owner's existing campus wide monitoring system. Mount controller to machine room wall to prevent vibration of solid state equipment. Dedicated permanent status indicators shall be provided on the controller to indicate the following: when the safety circuit is open, when the door locks are open, when the elevator is operating at high speed, when the elevator is on independent service, when the elevator is on fireman's service, when the elevator is out of service timer has elapsed or when the motor limit timer or valve timer has elapsed. In addition, provide means of displaying other special or error conditions that are detected by the microprocessor. The elevator shall not require the functioning or presence of the microprocessor to operate on car top inspection or hoistway access operation (if provided) in order to provide a reliable means to move the car if the microprocessor fails.
- The elevator controller shall utilize a microprocessor based logic system and shall comply with (ANSI/ASME 17.1) safety code for elevators. The control equipment shall have all control parameters stored permanently on erasable programmable read-only memories (EPROM), and shall have permanent indicators to indicate important elevator status's as an internal part of the controller. The system shall provide comprehensive means to access the computer memory for elevator diagnostic purposes without need for any external devices. Systems that require hook-up of external devices for trouble-shooting are not acceptable.
- Failure of any single magnetically operated switch, contractor, or relay to release in the intended manner or the occurrence of a single accidental ground or short circuit shall not permit the car to start or run if any hoistway door or gate interlock is unlocked or if any hoistway door or car door or gate contact is not in the made position. Furthermore, while on car top inspection or hoistway access operation, failure of any single magnetically operated switch, contractor or relay to release in the intended manner or the occurrence of a single accidental ground shall not permit the car to move even with the hoistway door locks and car door contacts in the closed or made position.
- Dedicated permanent status indicators shall be provided on the controller to indicate the following: when the safety circuit is open, when the door locks are open, when the elevator is operating at high speed, when the elevator is on independent service, when the elevator is on fireman's service, when the elevator is out of service timer has elapsed or when the motor limit timer or valve limit timer has elapsed. In addition, provide means of displaying other special or error conditions that are detected by the microprocessor.

- A motor timer shall be provided which, in the event of the pump motor being energized longer than a predetermined time, shall cause the car to descend to the lowest landing, open the doors automatically and then re-close them. The car calls shall then be canceled and the car taken out of service automatically. Operation may be restored by cycling the power disconnect switch or putting the car on access or inspection operation.
- A valve limit timer shall be provided which shall automatically cut off the current to the valve solenoids if they have been energized longer than a predetermined time. The car shall then be canceled and the car taken out of service automatically. Operation may be restored by cycling the power disconnect switch or putting the car on access or inspection operation.
- An out of service timer (T.O.S.) shall be provided which will automatically take the car out of service if the car is delayed in leaving the landing while there are calls existing in the building. The car shall not respond to hall calls while in this mode of operation, and the photo eye input shall be unresponsive in the event that a faulty photo eye unit was delaying the car.
- Door protection timer shall be provided for both the open and close directions which will help protect the door motor and which will help prevent the car from getting stuck at a landing. The door open protection timer shall cease attempting to open the door after a predetermined time in the event that the door is prevented from reaching the open position. The door close protection timer will reopen the doors for a short time in the event that the door closing attempt fails to make up the door locks after a predetermined time.
- A minimum of three different door standing open times shall be provided. A car call time value shall predominate when a car call only is canceled. A hall call time value shall predominate whenever a hall call is canceled. In the event of a door reopen from a photo curtain, or door open button, a separate short door time value shall predominate. The timing value for these timers must be field adjustable.
- Nudging: If the doors are prevented from closing for longer than a predetermined time, door nudging operation shall cause the doors to move at a slow speed in the close direction and to be unresponsive to the photo curtain. A buzzer shall sound while nudging operation is active.
- Hall or car call registration and lamp acknowledgment shall be by means of a single wire per call besides the power busses. Systems that register the call with one wire and light the call acknowledgment lamp with a separate wire are not acceptable.
- Fireman's Phase I emergency recall operation, alternate level Phase I emergency recall operation, and Phase II emergency in-car operation shall be provided according to applicable codes. Keyed (AZFS)
- Independent service operation shall be provided such that the actuation of a key switch in the car-operating panel will cancel any existing car calls, and hold the doors open at the landing. The car will then respond only to car calls and will ignore hall calls. Car and hoistway doors will only close by constant pressure on car call buttons or a door close button until the car starts to move. While on independent service, hall arrival lanterns or jamb mounted arrival lanterns and gongs shall be inoperative. Keyed (EPCO-1)
- Simplex selective collective automatic operation shall be provided for all single car installations. Operation of one or more car or hall call buttons shall cause the car to start and run automatically provided the hoistway door interlocks and car door contacts are closed. The car shall stop at the first car or hall call set for the direction of travel. Stops shall be made in the order in which the car or hall calls set for the direction of travel are reached, irrespective of the order in which they were registered. If only hall calls are set for the opposite direction of travel exist ahead of the car, the car shall proceed to the most distant hall call, reverse direction, and start collecting the calls. For multiple car installations use duplex, triplex etc.
- The car shall be equipped with two-way leveling to automatically bring the car within plus or minus (1/4") of landing level at any landing regardless of load.

- A selector switch shall be provided on the controller to select high or low speed during access or inspection operation as long as speed does not exceed 150 feet per minute.
- A test switch shall be provided. In the "test" position, this switch shall allow independent operation of the elevator without the door open function for purposes of adjustment or testing the elevator. The elevator shall not respond to hall calls shall not interfere with the other car in a duplex installation.
- A timer shall be provide to limit the amount of time a car is held at a floor due to a defective hall call or car call including stuck push-buttons. Call demand at another floor shall cause the car to eventually ignore the defective call and continue to provide service in the building.
- Viscosity Control (optional and valve design must permit the use of this option) shall cause the car to accomplish the following operation. If a temperature sensor determines the oil is too cold, and if there are no calls registered, the car shall proceed to the bottom landing and, as long as the doors are closed, the pump motor will run without the valve coils energized in order to circulate and heat the oil to the desired temperature. In the event the temperature sensor fails, a timer shall prevent continuous running of the pump motor.
- **Solid State Motor Starter**
 - Provide a new solid-state motor starter to limit current inrush during starting and to provide gradual acceleration of the motor.
 - Motor starting shall not be initiated by mechanical contacts.
 - The starter shall include a current limit adjustment range of 200% to 450% of the overload adjustment range.
 - Provide an internal fault detection system, if the internal fault detection system detects a failure, power shall be removed from the motor.
- **Hydraulic Jack**
 - Install plunger-cylinder units plumb and accurate.
 - Plunger to be machined from extra heavy steel pipe (A53, Grade B) or equivalent mechanical tubing and ground to 24-32 or better micro-inch finish. The upper end of the plunger is equipped with a heavy steel plate inset and fillet welded into the plunger wall. This plate is drilled and tapped to receive standard machine bolts for attachment to the load platform. The bottom end of the plunger is provided with a steel striker plate welded to the plunger. Where the plunger is of multiple-piece construction, the coupling end is machine-bored, faced, and internally threaded to receive the coupling. All plunger joints are assembled and machined across the joint to assure matching surfaces.
 - Install schedule 40 PVC auxiliary casing with bottom completely sealed. Size casing for minimum 1.5" clearance to all jack assembly components.
 - Install piping without routing underground. Where not possible, rout piping through schedule 40 PVC before back filling.
 - Hydraulic hose for sound deadening is not permitted.
- **Hydraulic Pump**
 - Pumping Unit: The pumping unit shall be of integral design and shall include an electric motor connected to a submersible pump, a hydraulic control system, hydraulic fluid reservoir and necessary piping connections all compactly designed as a self-contained unit. This unit shall be designed for vibration free operation. The unit shall be factory adjusted and tested before shipment to the job site. The testing procedure shall include actual job type conditions of load, speed, etc. Refer to the drawings for remote arrangement of hydraulic unit for this project.
 - The pump shall be specifically designed for all hydraulic operation and shall be of the positive displacement type. Oil flow shall be controlled in such a manner that car operation will be smooth and quiet in both directions of travel. Accurate car leveling shall take place in both the up and down direction. The control valve shall be easily adjusted from the front of the power unit.
 - The "up start" system shall be adjustable and designed to initiate the stop of the elevator and shall control the acceleration smoothly and evenly.

- The "down start" system shall be adjustable and designed to initiate the stop of the elevator and shall control the deceleration of the elevator smoothly and evenly.
- The power unit shall have a shut-off valve which will isolate the oil reservoir to enable servicing of the pump hydraulic assembly. The shut off valve shall be located in the machine room as directed by Owner.
- A suitable muffler designed to withstand the high pressure shall be installed in the power unit in a blowout proof housing.
- Submersible Pump: The submersible pump shall be a positive displacement screw type to give smooth operation and shall be especially designed and manufactured for elevator service.

- **Elevator Pit Hydraulic Oil Return Pump**
 - Drip Pan Return Pump: 120V fractional h.p. pump suitable for pumping of hydraulic fluid. Furnish pump with float activated on/off switch.
 - Drip Pan: 24 gauge, galvanized sheet metal of suitable size to accommodate return pump.

- **Door Equipment**
 - Heavy Duty G.A.L. MOVFR Door Operating System, G.A.L. door rollers, door hanger tracks (car and hall) door pick-up assemblies, gate switch, door locks.
 - Provide emergency access in all hoist way doors.
 - All doors shall have 1-1/2 hr. label or other identification acceptable to governing authorities.
 - Provide adjustable nylon guide (by Nylube or Adams Elevator Equip. Co.).
 - Heavy duty doors. Provide door skin on both sides of elevator doors.

- **Lobby Position Indicator**
 - Provide tamper resistant lobby position indicator on the ground level, illuminated by light emitting diodes. By Elevator Products Co. (EPCO).

- **Smoke Detectors**
 - Smoke and heat detectors shall be compatible and tie into building fire system.

- **Hall Direction Indicator**
 - Up and down tamper resistant SURVIVOR PLUS as manufactured by Elevator Products Co. (EPCO). Direction indicators to be provided in the hall wall with a single chime or tone for up and double chime or tone for down direction and shall be illuminated by light emitting diode.

- **Photo Curtain**
 - Photo Curtain: An electric, passenger sensing device of the photo curtain shall project across the entrance to prevent the car and hoist way doors from closing if a passenger or object interrupts the curtain.
 - Nudging: If the doors are prevented from closing for longer than a predetermined time, door nudging operation shall cause the doors to move at a slow speed in the closed direction and to be unresponsive to the photo curtain. A buzzer shall sound while nudging operation is occurring.

- **Car Operating Station**
 - Flush mounted operating panel shall be mounted in the car return panel and shall contain the devices required for the specified operation. The buttons and devices shall be of the easy readability type and the floor designation buttons shall become illuminated when pressed and shall stay illuminated until the floor call is answered. Provide continuous hinge on panel for easy access to internal components. Locate hinges on side of panel nearest wall of the elevator. The car operating shall contain the floor designations, and all the controls indicated.

- Digital car position indicator, illuminated with light emitting diodes.
 - Fan key switch (EPCO-1)
 - Emergency stop key switch (EPCO-1).
 - Independent service key switch (EPCO-1).
 - Inspection/access key switch (EPCO-2).
 - Firefighter service key switch (AZFS)
 - Alarm bell push type switch.
 - Light key switch (EPCO-1).
 - Engrave capacity and elevator designation.
 - Engrave “ INSPECTION CERTIFICATE ON FILE AT FACILITIES MANAGEMENT “
 - Emergency light.
 - Emergency light test button.
- Elevator Shutdown
 - Elevator power shall automatically shutdown prior to sprinkler activation. This is typically accomplished by the use of a shunt trip breaker activated by a heat detector.
 - Heat detector to be located no more than 24” from any fire sprinkler head installed in elevator shaft or machine room
 - Heat detector should also report to fire alarm system
 - Conduit circuits to shut down elevator power shall be monitored and supervised by the Fire Alarm System.

EXECUTION

- **Telecommunication Link**

- Install communication cable for controller modem not to exceed 24” from controller.
- Install communication cable for car phone not to exceed 24” from controller.
- Install modem MC – PA board and modem outlet inside of controller.

- **Adjust And Balance**

- Make necessary adjustments of equipment to ensure elevator operates smoothly and accurately.

- **Protection**

- Locate and protect movable equipment and controls in such a way that they can only be operated by authorized persons.

- **Inspections**

- Obtain and pay for inspections and permits and make sure tests are as required by regulations of authorities. Conduct all tests and inspections in the presence of the Owner.
- Final inspection shall be after all new equipment is installed and operating correctly.
- Inspect installation in accordance with ANSI-A17.2
- Deliver test certificates and permits to Owner.

- **Operation And Maintenance**

- Instruct Owner’s personnel in proper use, operations and daily maintenance of elevators.
- Training shall include operation of diagnostic microcomputer and servicing of elevator microprocessor.
- Make final check of each elevator operation, with Owner’s personnel present and just prior to date of substantial completion. Determine that control systems and operating devices are functioning properly.
- Continuing Maintenance: Provide 1-year maintenance on elevators on an as-needed basis as part of standard 1-year warranty on new equipment and upgrades.

- Maintenance shall include systematic examination, adjustment and lubrication of new elevator equipment; replacement of seals, packing and valves to maintain required factor of safety; performance of maintenance work without removing car during peak traffic periods and providing 24 hour emergency call back service during maintenance period, at an additional cost to Owner.
 - Repair or replace electrical and mechanical parts of the new elevator equipment using only genuine standard parts produced by manufacturer of equipment concerned.
 - Ensure that competent personnel handle maintenance service. Maintain an adequate stock of parts for replacement of emergency purposes, locally, and have qualified personnel available at such places to ensure the fulfillment of this service without unreasonable loss of time.
-
- **Cleaning**
 - Remove all trash and debris from site during elevator installation.
 - Clean all elevator surfaces, removing all dirt, dust, spots, and scratches. Any damage shall be repaired or replaced as directed by Owner, at no cost to Owner.
 - Prior to substantial completion, remove protection from finished or ornamental surfaces and clean and polish surfaces with due regard to type of material.
 - Remove tools, equipment and surplus materials from site.

End of Section 14240

DIVISION 14 - CONVEYING SYSTEMS

Section 14440 – Lifts

Introduction

The application and use of stair lifts to provide a means of wheelchair access on new and existing stairs requires careful consideration as these elements present significant operational, maintenance and safety concerns to the University. The University's experience has shown that only the following units provide reliable and trouble free service. Only the units identified below are to be considered acceptable for use on University projects.

Part 1 - General

Part 2 - Products

- Straight incline wheel chair lifts shall be Garaventa, model XPRESS II
- Vertical wheel chair lifts shall be Garaventa, model GVL-EN. Drive mechanism can be either hydraulic or screw type depending on the use and height of the lift.
- Curving or turning lifts, for going around corners or up a stairwell, shall be Garaventa models GSL-1 or GSL-3, depending on the specific needs of the unit.

Part 3 – Execution

- Factory assisted installation and set up is required for all lifts.

End Of Section 14440

DIVISION 15 - MECHANICAL

Section 15000 - General Requirements

Introduction

The work shall be in accordance with all rules, regulations, by-laws and requirements of all authorities having jurisdiction.

Refer any questions, clarifications regarding Division 15 to UA Planning Design & Construction.

Part 1 - General

- Codes
 - The project shall comply with the following codes (as adopted by the University Deputy State Fire Marshall):
 - Arizona State Fire Code
 - International Building Code
 - National Electrical Code)
 - International Mechanical Code)
 - International Plumbing Code
 - N.F.P.A. (as referenced in the adopted codes)
- Working In Confined Spaces
 - Whenever work is required within a confined space, e.g., utility vaults, utility tunnels, sumps, pits, sewers, etc., contact UA Risk Management Services and Safety Department for details and procedures on UA Confined Space Entry Program.
- Laboratory Design Criteria
 - Refer to UA DSS Tab C-3.
 - Discuss fume hood selection and HVAC system criteria with UA Planning Design & Construction.
- Record Drawings
 - Provide a set of prints and clearly mark, as the job progresses, all changes and deviations from that shown on Contract Drawings. Drawings shall be kept up-to-date during construction and in addition to field measurements shall include; change orders, field instructions and all other changes.
 - Reference Division 01300 for further details.
- Buried Services
 - After inspection and approval of service lines in trenches, provide a continuous trace wire and attach to service line directly. The Mechanical Contractor shall take 'as-built' measurements, including all depths, prior to commencement of backfilling operations. It will not be sufficient to check off line locations. Definite measurements shall be taken for each service line. The location of buried piping shall be shown on the drawings and dimensioned from fixed points.
- Temporary Use Of Equipment
 - Permission must be obtained from Architect/U of A prior to operating any mechanical systems during construction.
 - Where the mechanical systems are operated during construction, the Mechanical Contractor shall maintain the system and equipment in proper operating condition. (Note that the warranty period starts at

substantial completion)

- Before any area of the building is turned over to the U of A for acceptance and for beginning of the guarantee/warranty period, the systems and equipment shall be returned to the initial new condition e.g., by replacing used air filters with new air filters, cleaning the air side of all coils in the air handling systems, lubricating all bearings according to manufacturer's factory standards and adjusting control systems according to specifications and/or to suit the U of A.

- Provision For Future Expansion And/Or Installations
 - Where piping, ductwork and equipment is indicated for use in future expansion of the building and/or for future installations within the building, the Contractor shall leave sufficient clear space and install the piping, ductwork and equipment in such manner that connections to the future building expansion and/or future installations within the building can be made without removing existing floors, walls, ceilings. The Contractor shall consult with the Architect/U of A whenever necessary for this purpose.

 - Any piping stub-outs provided for future connections to domestic hot and cold water piping systems shall be arranged so that "dead legs" (i.e., pipe sections where there is no water circulation) are prevented. The termination point of any piping stub-out shall be as close to the main piping flow as physically possible. Where future branch lines must extend a distance greater than six (6) branch line pipe diameters or more than 18" from the main piping flow, a valved drain port or blind flange with a valved drain shall be provided at the end of the branch piping to allow periodic flushing.

 - Abandonment of Domestic Water Piping
 - Verify routing of existing domestic hot and cold water piping systems prior to their being abandoned. Cap abandoned branch lines as close as physically possible to the main piping flow to eliminate "dead legs". Elimination of "dead legs" shall not hinder the proper operation of any existing hot water return, i.e., recirculation, systems.

Part 2 - Products

- No discussion.

Part 3 - Execution

- No discussion.

End of Section 15000

DIVISION 15 - MECHANICAL

Section 15050 - Basic Mechanical Materials and Methods

Introduction

Mechanical systems materials and methods of installation common to some or all of mechanical systems sections in Division 15.

Part 1 - General

- All electrical work associated with Division 15 shall comply with requirements of Division 16.
- Refer to section 15990 For testing requirements

Part 2 - Products

Valves

- Sizes 6" and above shall have gear operator ball chain if located more than 7 ft. above floor.
- Provide isolation Ball valves - 100% full-port, full-line size, bronze-body, threaded connections at all equipment and on all main branch take-offs.
- Provide brass valve tags marked for the service. See pertinent service specification for valve type.
- Butterfly valves shall be 100% bubble-tight shut-off. Lug type only. Iron body with bronze disk. Valves to have two year warranty. Use for throttling/balancing. Preferred manufacturers are Norris, Centerline or UA approved equal.

Piping Labels

- Provide at directional changes and/or each 20 ft. Labels to be pre-manufactured snap-on plastic wrap-around type (where not exposed to UV) sized to cover entire circumference of piping and insulation.
- Where labeling exposed to UV, provide labels and fasteners that are metal or other material not susceptible to UV damage. Proposed product shall be approved by the University.
- Labels to have integral color identification as established by ANSI Standard A13.1 - 1981.
- Lettering shall be sized to be easily legible. Directional arrows shall indicate direction of flow and shall be located to point away from lettering.

Escutcheons

- Install in exposed locations, except in mechanical rooms.
- Escutcheons to be hinged, chrome-plated type.

Pipe Sleeves / Concrete Walls & Floors Above Grade

- Shall be schedule 40 steel.
- Sized for full dimensions of insulation and fire caulked where required.
- Install in all exterior walls, fire walls and floors.
- Sleeves are not required in cored concrete except wet area floors
- Floor sleeves to extend 1" above floor surface in wet areas.

Pipe sleeves in non-rated, non-masonry walls or partitions. Provide 24 gage galvanized steel.

Pipe sleeves in rated non-masonry wall or partitions – provide listed approved fire-rated assemblies.

Pipe sleeves installed below ground through exterior walls shall have mechanical type neoprene seals.

Pipe Hangers

- Use Vibra-Zorb cushioned supports on 1 ¼" pipe and smaller which is connected to vibrating equipment.
- Provide piping support hangers to ensure that no sags occur. Minimum hanger rod sizing and maximum hanger spacing shall conform to following table:

<u>Material</u>	<u>Pipe Size</u>	<u>Spacing</u>	<u>Hanger Rod</u>
Steel Pipe	½"	6'-0"	3/8"
	¾" through 1-¼"	8'-0"	3/8"
	1-½, 2"	10'-0"	3/8"
	2-½"	10'-0"	3/8"
	3"	12'-0"	3/8"
	4"	12'-0"	3/8"
	5"	12'-0"	1/2"
	6"	12'-0"	1/2"
	8-12"	12'-0"	5/8"
Copper Pipe	½"	6'-0"	3/8"
	¾", 1"	8'-0"	3/8"
	1-¼ through 4"	10'-0"	3/8"
	5" - 6"	12'-0"	1/2"
	8" and above	12'-0"	5/8"
Cast Iron	1 ½" - 2"	1 ea. Joint	3/8"
	3"	1 ea. Joint	1/2"
	4" through 6"	1 ea. Joint	1/2"
	8" and above	1 ea. Joint	5/8"
Vertical risers shall be supported at each floor line with steel riser clamps			

Equipment Nameplates.

- Provide nameplates for all pieces of equipment.
- Nameplate shall be minimum of 3/32" thick laminated phenolic plastic.

Access Doors

- Minimum size 12"x12" for wall access - provide 24" x 24" for ceiling access.

Motors

- Motors shall have premium efficiency EPAC rating in accordance with IEEE Standard 112 test method B.
- Motors shall have a minimum service factor of 1.15 and the design load shall not exceed 1.0.
- Motors located in conditioned space shall have an ambient rating of 104° F (40°C). Motors in unconditioned space shall have an ambient rating of 122°F (50°C).

Part 3 - Execution

Workmanship

- Piping to run parallel to building lines.
- Locate groups of pipes parallel to each other, spaced to permit valve servicing.
- Particular attention must be paid to the proximity of mechanical piping and equipment to electrical conduit and cable.

- All underground utility pipe shall have a tracing wire that is electrically continuous. The wire shall be 14TW AWG stranded (green) wrapped around or buried alongside the pipe. The wire shall be terminated at either end in a box flush with the ground with 3 feet of coiled wire in the box.
- Pitch piping in direction of flow 1" per 40 ft.
- Piping to be inspected and pressure tested prior to insulation.
- Piping to be routed to allow access to equipment.
- Welding to be done by welders certified locally in the State of Arizona. Welders must have proof of certification in their possession.
- Weld inspection
 - Visual inspection on low pressure piping (CHW, Condensate, LPS, HW, etc.).
 - Visual inspection and optional radiography on medium and high pressure steam piping (MPS, HPS).
- Do not support pipe with sleeve.
- Pipes on trapeze type hangers shall be firmly secured.

Installation

- Install strainers with full port ball valve on blowdown. Provide hose threaded connection on valves 3/4" and below.
- All gauges to be installed with a single gauge manifolded with ball valves on both sides of pumps, heat exchangers, tunnel supply and return, etc.
- Install valves with stems in vertical position except ball valves. Do not go below horizontal with ball valve stems.
- Use 10 mil plastic wrap around copper pipe on ferrous hangers or supports.
- Use dielectric fittings whenever joining dissimilar metals.

Equipment Installation/Removal

- Provide access to all equipment in accordance with the Mechanical code and Manufacturer's recommendations, for maintenance, servicing. And removal.
- Provide a means of removing any valve that is larger than 2" and is mounted six feet or more above floor level.
- Domestic Water Piping Arrangement
 - Provide recirculating loops for all domestic hot water piping systems with pipe runs longer than 50 feet.
 - Arrange piping in such a manner that there are no "transitory dead legs", i.e., piping branch lines that contain stagnant water. All abandoned branches or futures to be as close to main as possible, but in no case longer than 6" pipe diameters or 18" for pipe over 3".
 - Refer to "Provisions for Future Expansion and/or Installations" Section 15000 - General Discussion for the installation requirements of future connections.
- Electrical conduits shall not touch or be supported via pipes or ducts.
- Ensure fire and smoke separation rating of walls and floors is maintained via appropriate protection of openings and penetrations.

End of Section 15050

DIVISION 15 - MECHANICAL

Section 15250 - Mechanical Insulation

Introduction

Insulation products associated with:

- PIPING, DUCTWORK

Part 1 - General

- Use wrapped supply ductwork, except in acoustically critical applications where liner may be used only after written permission is given by the University. Lined ducts shall not be used in medical areas, clean rooms, or all high velocity supply ductwork.
- These requirements apply to building and tunnel piping. For direct buried chilled water piping discuss with the University.

Part 2 - Products

- Pipe Insulation Schedule (minimum insulation thickness)

Fluid Design Operating Range (°F)	Conductivity Range Btu•in./(h•ft ² •°F)	Mean Rating Temperature °F	Nominal Pipe Diameter (in.)				
			Less than 1	1 to 1 1/2	1 1/2 to 4	4 to 8	8" and larger
Above 350°F	0.32 - 0.34	250	4.5	5.0	5.0	5.0	5.0
251-350°F	0.29 – 0.32	200	3.0	4.0	4.5	4.5	4.5
201-250°F	0.27 – 0.30	150	2.5	2.5	2.5	3.0	3.0
141-200°	0.25 – 0.29	125	1.5	1.5	2.0	2.0	2.0
105-140°F	0.21 – 0.28	100	1.0	1.0	1.5	1.5	1.5
56 - 104°F	No Insulation Required						
40-55°F	0.21 – 0.27	75	0.5	1.0	1.0	1.0	1.0
Below 40°F	0.20-0.26	50	1.0	1.0	1.0	1.0	1.5

Note:
For insulation outside the stated conductivity range, the minimum thickness (T) shall be determined as follows:
 $T = r\{(1 + t/r)K/k - 1\}$ where T = minimum insulation thickness (in.), r = actual outside radius of pipe (in.), t = insulation thickness listed in this table for applicable fluid temperature and pipe size, K = conductivity of alternate material at mean rating temperature indicated for the applicable fluid temperature (Btu•in./h•ft²•°F); and k = the upper value of the conductivity range listed in this table for the applicable fluid temperature.

- Chilled Water Piping
 - All branch lines that are final connections to equipment 2" and below, valves, strainers and other piping appurtenances shall be insulated with closed cell foam insulation. Application shall be per Armaflex North American Application Manual. Extra care shall be taken to maintain the required Vapor barrier to prevent condensation.
 - All exposed metal surfaces shall be insulated when located above ceilings.
 - All chilled water ball valves operating below dew point are to be provided with insulated tee-handles such as NIBCO NIB-SEAL, Apollo Therma-Seal or equivalent.
 - Chilled water mains shall be insulated with fiberglass pipe insulation per schedule and applied per all manufacturer's instructions for piping operating below 45 degrees except tempered chilled water above dew point in chilled beam applications.

- Duct Insulation (minimum)
 - 2" fiberglass with foil back wrap with a minimum density of 0.75 lb./ft³.
 - 1" fiberglass duct liner with heavy duty surface, (see Part 1 - General).
 - Exterior ductwork to be insulated and lagged with aluminum jacketing.
- Pipe Insulation Jacket
 - Interior, concealed - fiberglass, All Service Jacket (ASJ). PVC jacket for chilled water in indirectly conditioned or potentially humid spaces.
 - Interior exposed or in equipment rooms –
 - Cover hot piping less than 10 feet above finish floor with 8 oz. Canvas jacket sealed with water based lagging adhesive and sizing compound, like Foster 30-30.
 - Chilled water piping- cover with PVC jacket
 - Tunnel piping
 - Steam and condensate -Canvas jacket sealed with water based lagging adhesive and sizing compound, like Foster 30-30
 - Chilled water - PVC jacketed
 - Exterior piping - fiberglass ASJ covered with embossed aluminum jacket with banding at joints and sealed with 25 year clear silicone.
 - Any insulated pipework installed within an air handling unit to be covered with PVC jacket.
- Equipment Insulation
 - Rigid, foil faced, fiberglass with a minimum density of 3.0 lb./ft³. Cold equipment (where fluid temperature is below 50 degrees F) shall be insulated with closed cell foam insulation. (Aramaflex or equal Misc. Product).
- Closed cell foam insulation which meets smoke developed/ flame spread ratings of 50/25 may be used where allowed by the code.

Part 3 - Execution

- Provide fitted insulation which can be removed and reused around equipment, valves, flanges, etc.
- Use Z-strips on all leading edges of duct liner, (when permitted).
- Insulated fittings, i.e., elbows, tees, Y's to be packed and fitted with PVC covers or pre-molded insulation and PVC covers if applicable.
- Install insulation per Manufacturers Installation Manual and latest edition MICA Standards.
- Use welded pins for ductwork insulation attachment. No mechanical or glued attachments allowed.
- For pipe sizes greater than 1¼" provide calcium silicate inserts and metal shields to protect the insulation at each support. Provide solid inserts for smaller pipe sizes.
- Domestic hot water piping shall be insulated.
- Cooling system condensate drain lines shall be insulated where pipe is subject to potential sweating, including roof and area drains carrying condensate.
- Piping carrying fluid below 65°F and all steam piping to be insulated continuously through clamping, support and sleeving.

- All supply duct work to be insulated. - Ductwork downstream of terminal boxes exposed within the conditioned space may be uninsulated.

END OF SECTION 15250

DIVISION 15 - MECHANICAL

Section 15300 - Fire Sprinkler Systems

Introduction

This work shall be in strict accordance with all rules, regulations, by-laws and requirements of all authorities having jurisdiction including, but not limited to the latest edition adopted by the University; NFPA codes, Arizona State Fire Code, UA Department of Risk Management Services.

Part 1 - General

- Hydraulic calculations and sprinkler system shop drawings shall be prepared and signed by a recognized design professional, to be submitted to the State Fire Marshal for approval.
- Designer and Contractor to conduct water supply static and residual tests, witnessed by UA, and provide fire flow information on shop drawings and hydraulic calculations.
- Provide a “Reduced Pressure” back-flow preventer located outside the building, with a 2½” flush port installed with a 2½” male hose connection controlled by a supervised valve and installed after the preventer but before the main alarm valve assembly.
- Provide a Potter Chemical Delivery System (PCDS-B) with Potter “Pipe Shield” chemical treatment and connect to the system after the alarm valve.
- Potter Automatic Air Bleeders (PARR-B) shall be installed at the most hydraulically remote point in each zone of the system. Each automatic air bleeder shall be provided with an isolation valve to allow for maintenance. Each automatic air bleeder shall be monitored by the fire alarm system for water leakage.
- Provide a metal sign mounted on the main riser with the hydraulic calculations engraved.
- Provide an 8 ½" x 11" Map Key Plan for each floor of building, indicating the location of the following:
 - Main Control Valves
 - Fire Alarm Panel
 - Fire Dept. Connection (FDC)
 - Location of interior FDC’s (wet or dry standpipes) if applicable
 - Back Flow Preventer
 - Fire Alarm Bell (24VDC)
 - Auxiliary Drain Valves
 - Inspectors Test Connections
 - Gallons per Floor / Zone
- Provide fire document box (#SSU00672 from www.1sae.com) at main control valve, complete with key plan,
- All valves shall be readily accessible for maintenance between 12 inches and 60 inches above finished floor.
- Provide a spare head box mounted next to the main control valve. Ensure there are sufficient quantity and type as required by NFPA 13 Standard for Installation of Sprinkler Systems, (latest University adopted edition). Ensure there is a head wrench and / or socket with ratchet as needed to replace any installed head in the system.
- Provide system signage and identification in accordance with NFPA 13 latest University adopted edition. Include placing signs on doors to all fire suppression equipment pumps, valves, test points, and drains.
- Provide a bound and “bookmarked” pdf copy of system “as-built” drawings for use of UA Fire Safety Dept.
- To facilitate the annual fire pump test, all fire pump installations shall include a fire pump test header (controlled by a supervised valve, with the discharge located outside in a location approved by UA). The test header shall be located as to allow the test to be performed without excessive flooding of the streets or damaging landscape.

- In buildings equipped with or to be equipped with fire pumps, provide monitoring to identify failure of jockey pump prior to start of fire pump due to loss of pressure.
- In buildings equipped with or to be equipped with pre-action sprinkler systems they shall be double inter-locked and shall use a nitrogen supply (Potter NGP Series) to reduce corrosion in the piping system. And shall be installed with a nitrogen bleeder at the remote point of the pre-action system.

Part 2 - Products

- Piping below grade shall be Cast Iron or AWWA C900
- Piping above ground shall be schedule 40 ASTM A-53 Grade A or B. or If "Pipe Shield" chemical treatment system is installed schedule 10 piping, Bull Moose, Dyna Flow, or equal may be used in the chemically treated part of the system.
- All grooved fittings shall be UL and FM approved. Victaulic 009H fittings are not to be used.
- All automatic air bleeders, chemical treatments, chemical injector systems, and nitrogen systems shall be manufactured by Potter.
- All control valves shall be gear operated butterfly type. minimum valve handle size is 5" diameter
- All non-control valves shall be ball type.
- All control valves shall have integrated tamper monitoring switches monitored by the fire alarm system.
- Provide electronic pressure monitoring of the supply and system sides of the fire sprinkler system using 24VDC ¼"NPT 4-20ma transducers that provide a range of 0-300psi with a burst rating of at least 400psi. They shall be installed in the same location as the system and supply pressure gauges. Each pressure transducer shall be monitored by the building fire alarm using a Simplex Analog Monitoring Zone Addressable Module (AMZ) part #4190-9050.
- All check valves shall be UL listed and Factory Mutual approved and shall be equipped with a removable cover assembly. Check valves shall be listed for installation in the vertical or horizontal position. Riser check valves shall be equipped with gauge connections on the system side and supply side of the valve clapper and a main drain outlet in the body of the valve above the rubber faced clapper assembly. Riser check valve trim piping to be externally galvanized. All check valves shall withstand a maximum water working pressure to 250 PSI.
- All FDC's shall be National Standard Hose thread.

Part 3 - Execution

- Piping shall be installed in areas protected from freezing. Designer shall route piping to avoid sprinkler lines being subjected to freezing. If piping must be located in areas subject to freezing obtain written approval from PD&C and Risk Management Services.
- U of A Risk Management Services and Facilities Management (FM)- Fire Safety to be notified 48 hours in advance of all system tests, e.g. underground flushing, hydrostatic test, flow alarm test, fire pump test (if applicable), fire alarm/final acceptance test.
- No saddle type fittings shall be used on fire protection systems.
- System main drain and auxiliary drain(s) sizes shall be in conformance with N.F.P.A. 13 – latest university adopted edition. Auxiliary drain valves shall be installed when trapped water will be collected in accordance with NFPA 13. A plugged or capped outlet will not substitute for a required drain valve. A sprinkler head will not eliminate a required auxiliary drain valve. Drains shall be routed through an exterior wall and shall be piped in galvanized piping where it extends through the wall. The exterior drain shall terminate at a turned down galvanized 45° ell to discharge at a splash block to prevent damage to the landscape. A gang drain may be used.
- Inspector's Test Connections and main drain shall be piped to a suitable location outside of building. (Confirm location with Risk Management Services and FM-Fire Safety Dept.). Do not pipe to a floor drain,

janitor's mop sink or similar. A gang drain system may be used.

- System piping shall not be buried beneath building slabs on grade.
- If a stand pipe is required, a combination wet standpipe / fire riser is preferred. All standalone standpipes shall be wet type with the exception of parking garages which shall be dry type (Dry piping shall be above ground). Locate the fire department connection (FDC) adjacent to the sprinkler system FDC.
- In all new construction and in major renovation projects the entire system shall have a final "all heads installed" 2 hour 200 psig pressure test through the FDC. Isolate the RP Backflow device during the test.
- Check valves, sprinkler valves and flow switches and main drain valve shall be readily accessible.
- At check valves, support piping independent of valve to allow for service removal without additional pipe support.
- FDC shall be horizontal type, wall mounted to the building structure on the street side by the main entrance, at a point as close as possible to the nearest fire hydrant, and shall be mounted in an area un-obstructed by building features to include landscaping. (Minimum 5ft clear on both sides). As an alternate the FDC can be integrated with the reduced pressure backflow preventer located in a location approved by Risk Management Services and FM-Fire Safety. Inspector's test valve shall be installed at the most hydraulically remote point in each zone of the system.
- Local bell shall be powered and supervised by the fire alarm panel.
- For all installations, do not use saddle tees. Use grooved fittings or welded outlets only.
- All welding of fire suppression piping shall be done by welders qualified in accordance with the minimum requirements of ASME Section IX Welding and Brazing Qualifications. Ensure all piping:
 - Is clear of discs
 - Has smooth openings
 - Welds are free from cracks
 - Is clear of weld splatter
- Do not enclose grooved fittings within construction.
- All pendant sprinkler heads in suspended ceilings to be installed at quarter points or center of ceiling tile.
- Shop drawings shall incorporate all of the design features shown on the contract drawings. Any deviations deemed necessary by the designer shall be clearly identified on the shop drawings, ie: clouded.
- Contractor shall submit shop drawings to the Architect/ Engineer and PDC Project Manager for review and approval, prior to submittal to the University of Arizona Fire Marshal.
- All new construction and major renovation projects shall be fully sprinklered and equipped with class A fire alarm system.

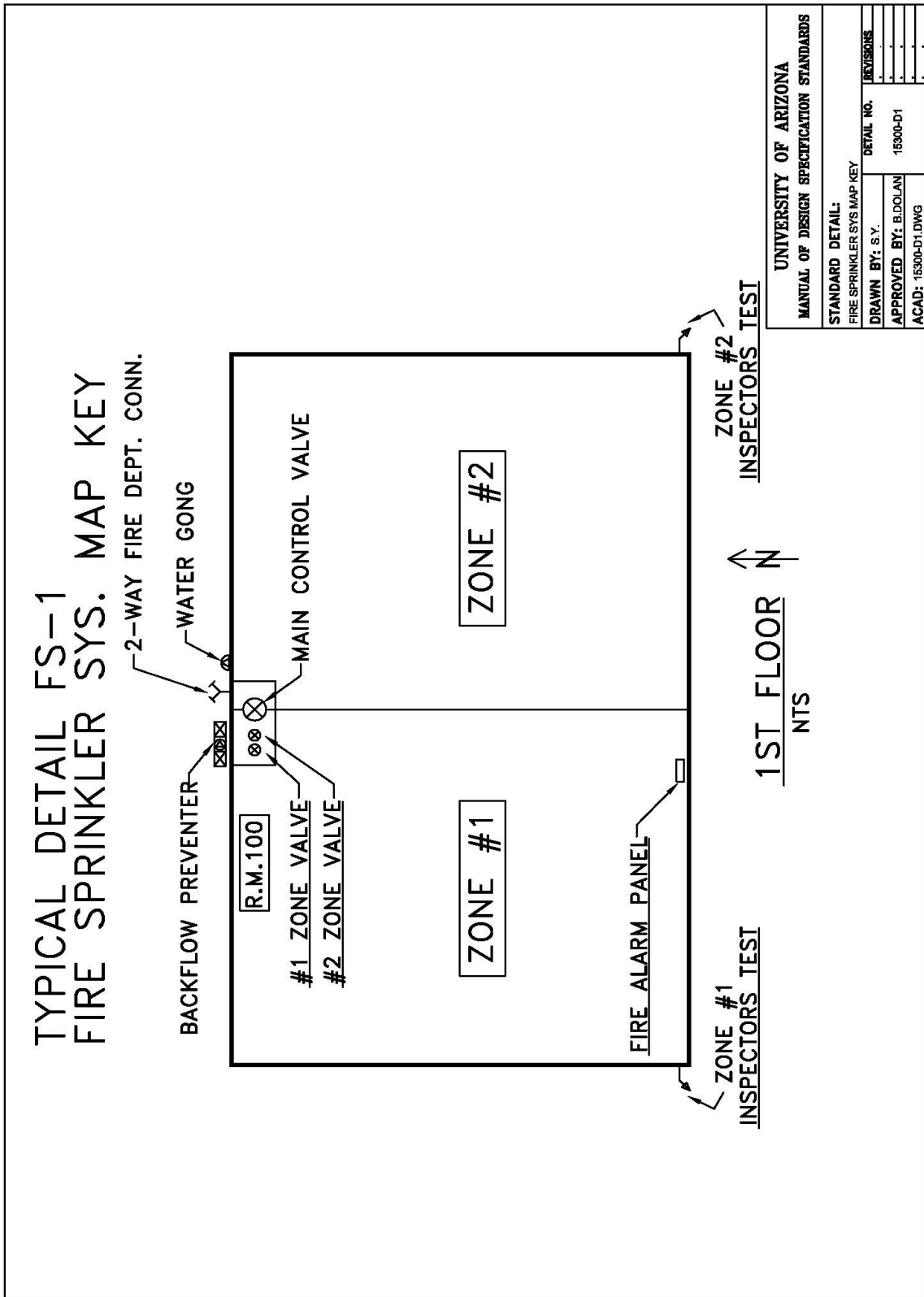

End of Section 15300

DIVISION 15 - MECHANICAL

Section 15410 - Plumbing Piping And Specialties

Introduction

Piping and specialties associated with plumbing systems including:

DOMESTIC WATER SYSTEMS, SANITARY SEWER AND WASTE PIPING SYSTEMS, LABORATORY
WASTE SYSTEMS, NATURAL GAS

Part 1 - General

- Refer to 15050 for common piping materials and methods.
- Single stack waste vent systems (sovent) shall not be designed into any facility.
- Refer to meter requirements (attachment to Section 15970).
- Refer to section 15990 For testing requirements.

Part 2 - Products

Pipe Schedule

<u>Service</u>	<u>Size</u>	<u>Pipe Material</u>	<u>Fittings</u>	<u>Joints</u>
Domestic Water (above grade)	Up to 2"	Copper Type "L" seamless Hard Drawn	Wrought Copper or Cast Brass	Non lead bearing solder
	2 1/2 " and larger	Copper Type "L" seamless Hard Drawn	Wrought Copper	15% Silver Brazed
Domestic Water (below grade)	All	Copper Type "K" seamless Hard Drawn	Wrought Copper	15% Silver Brazed
Low pressure Natural Gas (above grade)	Up to 2"	Schedule 40 Black Steel	Steel	Threaded
	2 1/2 " and Larger	Schedule 40 Black Steel	Black steel	Beveled Weld
Low Pressure Natural Gas (Below grade)	All	Same as above grade with sealed coating		
Drainage/Vent Piping (except Lab waste)	All	Cast Iron Service weight	Cast	Hubless with Husky SD 2000 assemblies or UA approved equal
Sanitary Sewer/Waste below Grade	All	Cast Iron Service weight	Cast Iron	Hubless with Husky SD 4000 assemblies
		PVC schedule 40	PVC sch 40 DWV	Solvent weld
Sanitary Sewer/Waste Above Grade	All	Cast Iron Service weight	Cast Iron	Hubless with Husky SD 4000 assemblies
Laboratory Waste/Vent	All	Polypropylene	Polypropylene DWV	Fusion welded
		CPVC schedule 40	CPVC DWV	Solvent Welded

<u>Service</u>	<u>Size</u>	<u>Pipe Material</u>	<u>Fittings</u>	<u>Joints</u>
High Temperature waste (autoclave cage wash, etc.)	All	Duriron	Duriron DWV	Mechanical Joint

- Back Flow Prevention: Backflow prevention standards will be equal to or greater than USC's Foundation For Cross-Connection Control and Hydraulic Research Manual #9, or the newest edition printed.
- Hose Bibbs: Keyless in public areas.
- Wall Hydrant: Automatic-draining, anti-backflow type. Provide one operating key.
- Floor Drains: Cast iron body. Floor drains for use as area drains in exterior slab on grade shall be furnished with anchor flange. . Airgap fittings shall be cast iron or cast bronze, with fixed air gap, inlet for drain pipe or tube, and threaded or spigot outlet. Provide seepage flange at all floor drains in suspended slabs. Provide inline trap protection at all floor drains.(Proset trap guard or equal)
- Floor sinks: Acid resistant enamel coated cast iron. Strainer/grating shall be chosen appropriate for service.
- Roof Drains and Overflow Drains: Cast iron roof drain with cast metal dome strainer.
- Roof Flashing Assemblies: Construct of four pound per square foot lead (min. of 24" x 24" cut for drain and clamped at collar).

Part 3 - Execution

- Excavation for buried piping shall be graded to provide a smooth foundation throughout length of piping. Bedding with clean sand to indicated level. Dig bell holes at each pipe joint to relieve protrusions of loads and to ensure continuous bearing of pipe barrel on foundation.
- Install sanitary building drain piping at a minimum slope of ¼" per foot (2 percent).
- For natural gas piping, provide dirt leg at each point of connection to equipment.
- Install cleanouts in drain piping as required by the plumbing code and at each sewer main change in direction of 90°, at minimum intervals of 50 feet for piping 4 inches and smaller and 100 foot minimum intervals for larger piping. Install cleanouts at the base of each vertical soil or waste stack. Exterior cleanouts shall be two-way.
- Extend wall cleanouts out to finished wall.
- Reduced pressure backflow preventers shall be installed at service into building, and at connections between potable and non-potable water systems.
- Anti-siphon, pressure type vacuum breakers shall be installed at connection to irrigation systems.
- Install laboratory waste piping in an accessible pipeway.
- Island Venting is not to be used for laboratory waste.
- Install strainer on building potable water supply after building shut-off and prior to backflow preventor.
- Install ball valves with hose end threads for system drains.
- Water hammer arrestors to be sized according to number of fixture units and installed on all branches with

quick closing devices (e.g. flush valves, solenoid valves, etc.). Quantity and location of arrestors shall be shown on the design drawings and follow Standard PDI WH 201.

- Provide floor drains for all wet areas. Floor sinks shall be used for indirect waste only. Floor sinks shall be installed with rim above finished floor.
- Ball valves to be threaded ends with downstream union.
- Top of floor drain grate shall be the lowest point on the floor and shall readily drain the entire floor.

End of Section 15410

DIVISION 15 - MECHANICAL

Section 15440 - Plumbing Fixtures

Introduction

Fixtures and appurtenances associated with the use of plumbing system piping including:

DOMESTIC WATER SYSTEMS, SANITARY SEWER SYSTEMS

Part 1 - General

- Refer to Section 15000 "Provisions for Future Expansion and/or Installations and Section 15050 Part 3 - Execution".
- All fixtures shall be of the "water saving type".
- Install fixtures as required for either standard or handicapped accessible service per ADA.

Part 2 - Products

- Water Closets, Wall Mount shall be/provided with:
 - Vitreous china construction, white
 - Elongated bowl
 - 1 ½" inlet spud
 - Siphon jet action
 - ANSI Standard A112.19.2
- Toilet Seats shall be:
 - Open front.
 - Injection molded of high strength, impact, and chemically resistant polypropylene.
- Flushometers
 - Manufactured by Sloan (Royal # 111 for water closets 1.6 gpf, Royal #186 for urinals, 1.0 gpf)
- Faucets And Trim shall be/provided with:
 - Cast brass with polished chrome plating.
 - All faucets and trim furnished shall be by Chicago Faucet or American Standard.
 - No push button faucets.
 - Single lavatory faucet for rest rooms (no hot water).
 - Moderators
 - Plug and tailpiece: P.O. plug with 13" tailpiece. Non-removable strainer with integral spud. (No. 327)
 - DI water faucets shall be PVDF lined, self closing, with swing gooseneck.
- Wall Mount Lavatories shall be/provided with:
 - Vitreous china with:
 - Front overflow
 - Self-draining deck area with contoured back and side splash shields
 - 4" centers or as required for handicapped faucets
 - Equipped for carrier
 - ANSI Standard A112.19.2

- Urinals shall operate as waterless with Ecoblue cubes as follows:
 - Urinals to be vitreous china, white, Zurn Model number Z5750
 - Provide programmable Flushometer with Ecoblue flush control (EAUTO)
 - Tailpiece to be PVC-DWV pipe (no copper to be used to eliminate corrosion issues)
 - Two wall hangers
 - ASME Standard A112.19.2 M-95, ANSI Z 124.9-94
- Mop Sinks (Floor Service Sink) shall be/provided with:
 - Acid resisting, enameled cast iron
 - Removable vinyl-coated rim guard
 - 3" drain
 - ANSI Standard A112.19.1.M
- Service Sinks shall be/provided with:
 - Acid Resisting, enameled cast iron
 - Rim guard
 - Wall Hanger
 - Drilled for back mount faucet
 - Floor supported trap
 - ANSI Standard A112.19.1.M
- Stainless Steel Sinks shall be/provided with:
 - 18 gauge brushed stainless steel.
 - Flat back extension with centerset holes 8" on center for faucet set.
- Water Coolers shall be/provided with:
 - Single unit, installed at height for handicapped accessibility/operation.
 - One-piece stainless steel backsplash plate and basin.
 - Exterior casing to be stainless steel or vinyl coated steel.
 - 8.0 gallons per hour minimum capacity.
 - Non-CFC refrigerant.
 - Fittings, Except Faucets
 - Angle stops and other fittings shall be fabricated of brass with a polished chrome plated finish.
 - Trap piping and tailpiece shall be chrome plated finish.
 - Escutcheons: polished chrome-plated, steel shell wall flange with friction clips.
- Plumbing Fixture Supports shall be/provided with:
 - ASME rated for service.
 - Chair carriers: supports with steel pipe uprights for wall hanging fixtures. Heavy duty chair carrier shall have rectangular steel uprights.

Part 3 - Execution

- Refer to Section 15000 "Provisions for Future Expansion and/or Installations and Section 15050 Part 3 - Execution".

- Installation
 - Install stop valves in a readily accessible location.
 - Install escutcheons at each wall and ceiling penetration in exposed locations and within cabinets and millwork. Use deep pattern escutcheons where required to conceal protruding pipe fittings.
 - Seal fixtures to walls, floors, and counters using a sanitary type, one part, mildew resistant white silicone sealant.
 - Single faucets shall not be used in conjunction with cock hole covers. Provide lavatory or sink with correct hole configuration for specified service.

End of Section 15440

DIVISION 15 - MECHANICAL

Section 15450 - Plumbing Equipment

Introduction

Equipment associated with building plumbing systems including:

WATER SOFTENER, SEWAGE EJECTOR PUMPS, HOT WATER GENERATORS, WATER HEATERS, WATER PRESSURE BOOSTER SYSTEMS.

Part 1 - General

- For energy conservation purposes, hot water shall not be provided to rest rooms.
- Use central plant steam via heat exchangers for hot water. Consider impact of summer shutdown of steam service, (back up systems may be required) - consult with UA Planning Design & Construction.
- Where used, water heaters shall be placed as near point-of-usage location as possible. Pumped recirculation system is required for piping systems lengths exceeding 50 feet.
- Small clear water ejector systems (fractional horsepower only) may use drop-in submersible pump.
- Autoclaves shall be connected to campus steam system and not furnished with individual steam generators. Verify adequate steam supply main pipe size and available pressure. Provide timers with over-ride button to shut off steam and water when not being used.

Part 2 - Products

- Water Softeners shall be dual automatic regenerating type to provide service during routine maintenance, complete with fiberglass tanks.

Sewage Ejector Pumps shall be self-priming, base mounted pump with suction line extended to sewage pit, high water alarm to U of A Campus EMCS. Provide two sewage ejector pumps for stand-by service with lead/lag control for building service application. Provide vent bleed valve per manufacturer's recommendation. Preferred manufacturer is Gorman Rupp or UA approved equal.

- Water Heaters - Gas fired preferred, although electric spot heaters may be used where economically justified. Lined galvanized steel tanks. 80% minimum efficiency.
- Water Pressure Booster System shall be Duplex pumping system, with removable bladder type hydropneumatic pressure tank. Booster pumps to have VFD's and be connected to the building EMCS (section 15970). Use of proprietary control systems from system manufacturers is not acceptable. VFD's must comply with DSS section 15870.
- Multi-plex pumps shall each have an H-O-A switch, disconnect, and overcurrent protection.

Part 3 - Execution

- All equipment shall be installed with isolation valves (threaded ball or flanged butterfly) - 100% full-port, full line size, bronze body at the equipment, drains, thermometers (on heat exchange equipment) and pressure gauges.
- Provide drip pans with piped drain beneath water heaters placed in areas other than in equipment rooms.

- Provide line size (2" maximum) full port ball valve blowdown on each side of heat exchangers (typically 4).

End of Section 15450

DIVISION 15 - MECHANICAL

Section 15480 - Plumbing Special Systems

Introduction

Special plumbing systems including:

LABORATORY WATER SYSTEMS, MEDICAL GAS SYSTEMS, COMPRESSED AIR SYSTEMS, VACUUM SYSTEMS

Part 1 - General

- Refer to section 15990 For testing requirements

Part 2 - Products

- Pipe Schedule

<u>Service</u>	<u>Size</u>	<u>Pipe</u>	<u>Fittings</u>	<u>Joints</u>
Laboratory RO water	All	Schedule 80 PVC	Schedule 80 PVC	Solvent Welded
High Purity Water	All	Polypropylene Type 1 Schedule 80	Polypropylene Type 1 Schedule 80	Fusion Weld Mechanical Joint
Medical Gas	All	Copper Type "L" Oxygen Grade	Wrought Copper	15%silver Solder
Compressed Air	All	Copper Type "L"	Wrought Copper	Less Than 0.2% Lead Alloy Solder
Lab Vacuum	All	Copper Type "L"	Wrought Copper or Cast Brass	Less Than 0.2% Lead Alloy Solder
Specialty Gases	All	Review with User for requirements and discuss with PD&C		

- Laboratory High Purity Water Systems
 - Utilize campus-wide RO water system where available with local filtration purifiers where required by user.
 - Where building wide high purity water is required, utilize a complete system by a single manufacturer to ensure a single point of responsibility.
 - Piping system shall be Schedule 80 PVC solvent welded for campus-wide RO system.
 - No tapered connectors shall be utilized on faucets.
 - Sterilize system before handover to U of A.
- Compressed Air Systems shall be/provided with:
 - Oil-less compression for medical application.
 - Automatic drain valve c/w isolation valve.
 - Air dryer with air dryer bypass valve (if required).
 - Conditioned inlet air preferred.
 - Filter inlet.
 - Oil and moisture separators.

Part 3 - Execution

- Workmanship
 - System Cleaning - fill laboratory water systems and hold water for 24 hours prior to flush. Flush clean 3 times.

- All vacuum pumps must be vented to the exterior of the building.
- Vacuum pump tanks must be drained to waste container.
- Provide bypass around filter assembly for servicing.
- Purge medical gas systems with nitrogen during soldering.

SPECIAL GASES MANIFOLD DIAGRAM

NOTE:
RACK PIPING MANIFOLD/ HEADER ASSEMBLY
& COMPONENTS ON WALL W/ UNISTRUT.

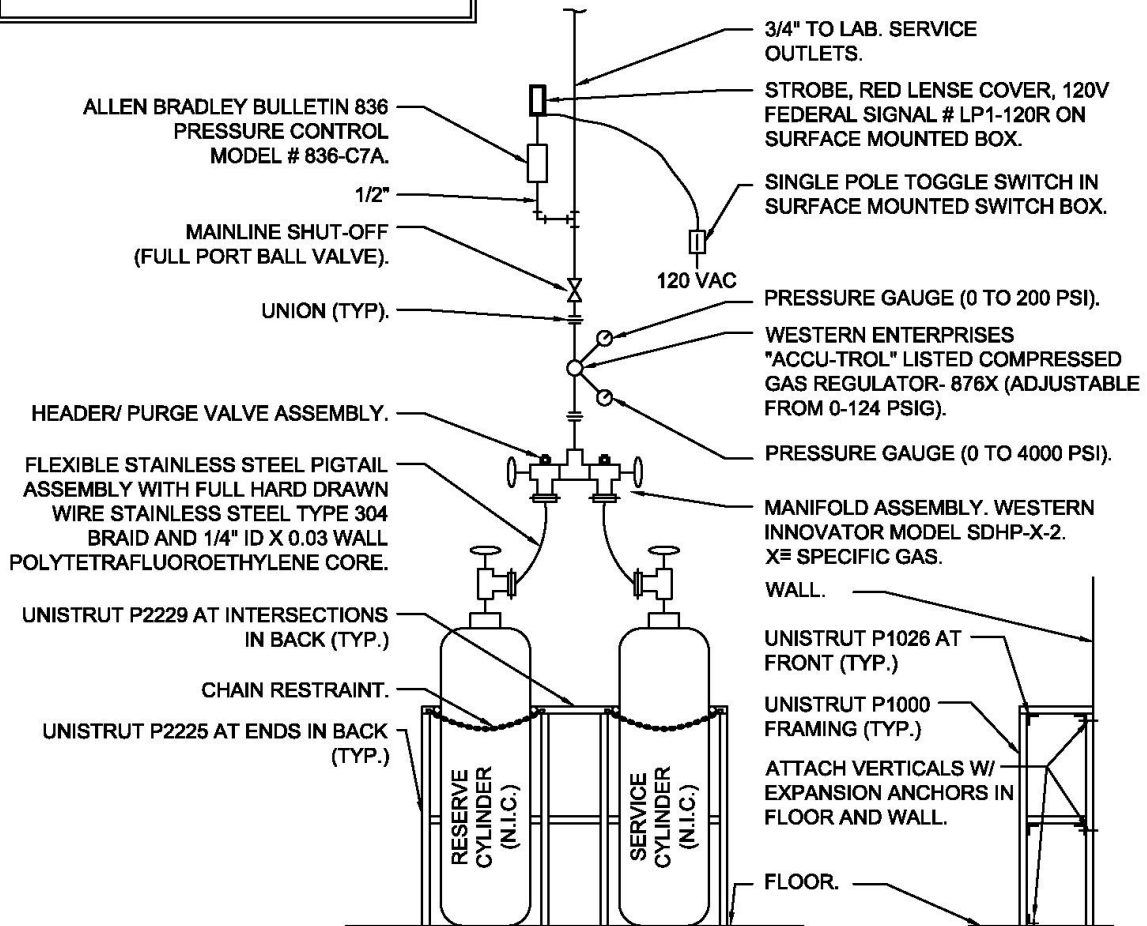

NOTE:
PRESSURE SWITCH/ CONTROL SHALL ENERGIZE
STROBE WHEN MAIN LINE PRESSURE IS 15 PSIG
LESS THAN SYSTEM DISCHARGE (SETTING)
AT PRESSURE REGULATOR.

SERVICE SCHEDULE		
SERVICE	PIPE SIZE	PRESSURE
ARGON	3/4"	80 PSI
HELIUM	3/4"	80 PSI
NITROGEN	3/4"	80 PSI

NOTE:
WALL MOUNTED CYLINDER BRACKET SIMILAR
TO GRAINGER SERIES 4ZH MAY BE USED
INSTEAD OF UNISTRUT SUPPORT WITH USER'S
PERMISSION.

DRAWING 15480

UNIVERSITY OF ARIZONA MANUAL OF DESIGN SPECIFICATION STANDARDS		
STANDARD DETAIL: SPECIAL GASES MANIFOLD DIAGRAM		
DRAWN BY: KML	DETAIL NO.	REVISIONS
APPROVED BY: S. H.	15480-D1	
ACAD: 15480		

DIVISION 15 - MECHANICAL

Section 15510 - Hydronic Piping and Specialties

Introduction

Piping and specialties associated with heat transfer equipment including:

CHILLED WATER, PROCESS COOLING WATER, CONDENSER WATER, HEATING WATER

Part 1 - General

- Install a strainer with differential pressure transmitter to EMCS on building side of isolation valve for chilled water supply from tunnel system. Install a single pressure gauge across strainer (see Section 15050 requirements).
- Use reverse return piping concept and eliminate balancing devices for all banked coil applications.
- Use circuit setting devices in closed loop systems. Preferred design is a variable flow pumping system controlling system differential pressure and using externally adjustable pressure dependent circuit setters at each point of use.
- Provide 3-way valves in heating water piping at end of branch line units only.
- Design heating water systems with a 40°F temperature differential. – (140 °F- 180 °F)
 - Refer to meter requirements (attachment to Section 15970).
- Refer to section 15990 for testing requirements.

Part 2 - Products

- Pipe Schedule

Size	Pipe	Fittings	Joints
Above ground			
Up to 2"	Copper Type "L" seamless hard drawn	Wrought copper	Less Than 0.2% Lead Alloy Solder
2 ½:" and larger	Copper Type "L" seamless hard drawn	Wrought copper	15% silver brazed
	OR		
	Schedule 40 Black steel	Forged Carbon Steel	Bevel Welded
Below ground			
Up to 2"	Copper Type "K" seamless hard drawn	Wrought copper	6% silver solder
2 ½:" and larger	Copper Type "K" seamless hard drawn	Wrought copper	15% silver brazed
	OR		
	Ductile iron	Ductile iron	Push-on or Mechanical

- Pipe Gasketing - Water Services - Garlock or UA approved equal.
- Valve Types: Butterfly, Globe or Ball. No Gate Valves shall be used.

- Preferred manufacturers are Norris, Centerline or UA approved equal.
- Thermometers
 - Adjustable angle type 9" die cast aluminum thermometer with separable well. Select with normal operating range at the midpoint of the scale. Install thermometer on both sides of each flow stream across coils, heat exchangers, etc.
- Pressure Gauges
 - Cast aluminum with 4 ½" dial. Select with normal operating range at the midpoint of the scale. Provide with pressure snubber and shutoff valve.
 - Provide gauges at each pump, AHU coil, and heat exchanger.
 - Use a single gauge manifold with valving on each side of equipment.
- Expansion Tanks
 - Provide diaphragm-type compression tank with replaceable diaphragm.
- Air Vents
 - Provide automatic float and trap air vents in mechanical rooms only.
- Expansion Joints
 - Provide bellows type. Type 316 stainless steel.
- Pressure Regulators
 - Brass body, threaded connections.
- Flow Regulating Devices
 - Circuit setter with external adjustment and indicator with threaded connections only.
 - Pressure independent flow balancing - restrict use to areas approved by the U of A.
- Hoses
 - High pressure, braided stainless steel and rated for temp and pressure requirements.

Part 3 - Execution

- Weld inspection: see Specification 15050 Part 3 Execution.
- Perform a minimum of three passes on weld joints (root, filler, cap).
- Route piping to allow sufficient access to all equipment, valves, controls, etc., for maintenance.
- In general, piping shall be installed below electrical conduits not requiring maintenance access.
- Piping shall be secured at each trapeze hanger or support.
- Install piping sufficiently below structure to allow top air vents.

- Provide isolation valves on each side of strainers and full port ball valve on blow down. Provide hose thread connection on blow down port $\frac{3}{4}$ " and below.
- Provide air vent with isolation valve at all system high points. Install automatic air vents in equipment rooms and manual air vents elsewhere. Automatic air vents are to be piped to drain. Minimum vent piping size is $\frac{1}{2}$ ".
- Provide ball valves with hose end threads for system drains.
- When an existing system "hot tap" is necessary, provide a full port ball valve to isolate the new branch line.
- Do not use circuit setter as isolation valve.

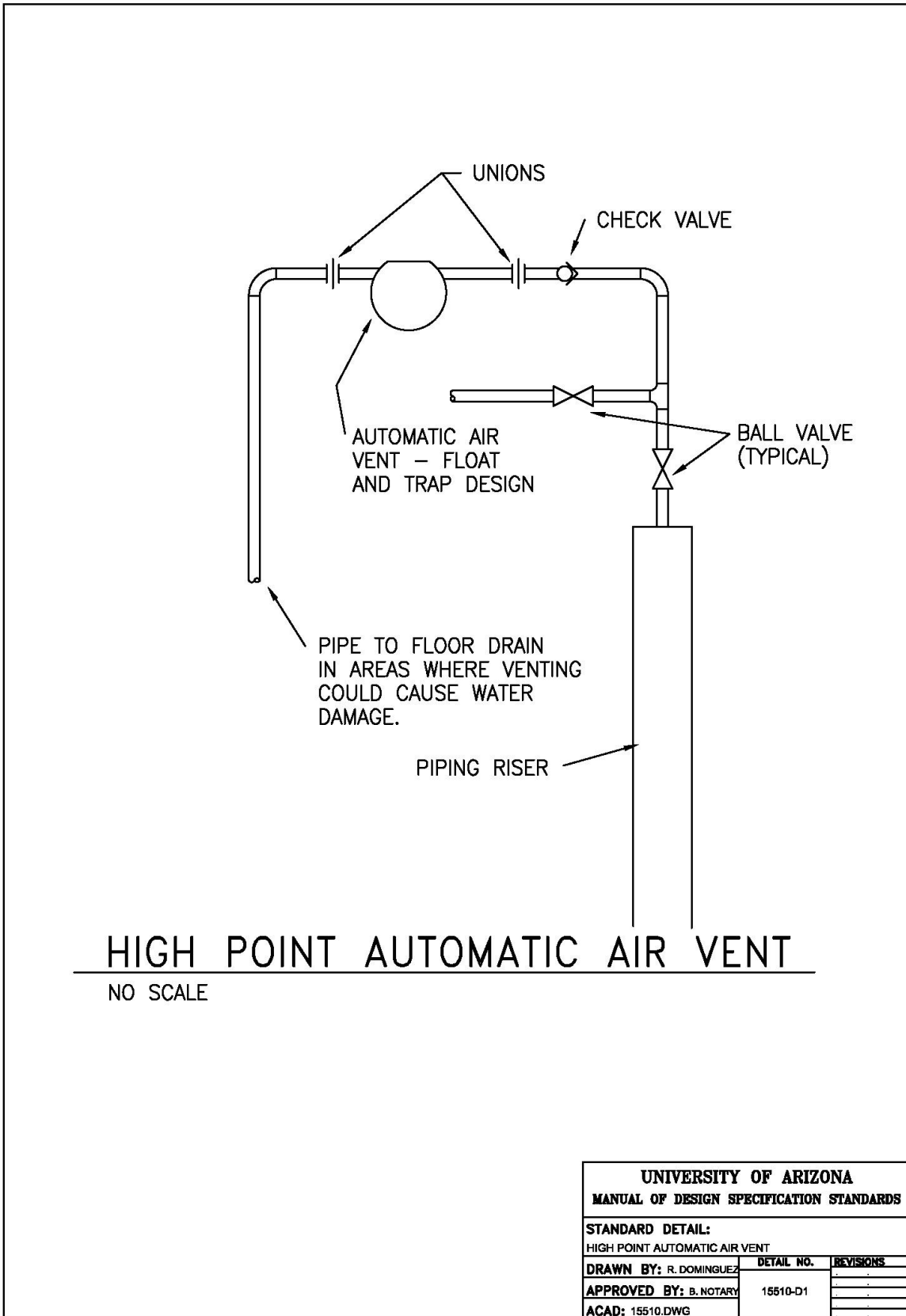

UNIVERSITY OF ARIZONA		
MANUAL OF DESIGN SPECIFICATION STANDARDS		
STANDARD DETAIL:		
HIGH POINT AUTOMATIC AIR VENT		
DRAWN BY: R. DOMINGUEZ	DETAIL NO.	REVISIONS
APPROVED BY: B. NOTARY	15510-D1	
ACAD: 15510.DWG		

End of Section 15510

DIVISION 15 - MECHANICAL

Section 15520 - Steam Piping and Specialties

Introduction

Piping and specialties associated with:

STEAM AND STEAM CONDENSATE SYSTEMS

Part 1 - General

- Comply with applicable codes
- Refer to section 15990 For testing requirements

Part 2 - Products

- Pipe Schedule -

<u>Service</u>	<u>Size</u>	<u>Pipe</u>	<u>Fittings</u>	<u>Joints</u>
Steam	Up to 2"	Schedule 80 seamless black steel	Forged carbon steel	Threaded, bevel weld or socket weld
	2 ½ " and larger	Schedule 40 seamless black steel	Forged carbon steel	Bevel welded
Condensate	All	Copper type L seamless hard- drawn	Wrought copper	15% silver brazing

- Pipe Gasketing - Steam services – Spiral wound – “Flexataulic” or UA approved equal.
- Valves
 - Condensate valves to be steam rated ball valves.
 - Steam valves to be steam rated globe valves.
 - Provide valves at all equipment and on all main branch take-offs.
- Pressure Gauges Shall Be:
 - Rated for steam service.
 - Cast aluminum with 4 ½" dial.
 - Selected with normal operating range at the midpoint of the scale.
 - Furnished with pressure snubber and shutoff valve.
 - Installed on both sides of all pressure regulators.
 - Installed at the inlet of at all steam using equipment.
- Strainers Shall Be:
 - Screwed 250# cast-iron, threaded through 2".
 - Flanged (150 lb.) 2 ½" and larger cast iron.
 - Size 100 mesh.
 - Installed ahead of steam traps and control valves.
- Steam Traps: Preferred manufacturers are.
 - Armstrong bucket for end of line drip and main lines.

- TLV float & thermostatic for modulating service.
- Pressure Regulators Shall Be:
 - Fisher, Industrial Type 92B.
 - Globe valve in by-pass.
 - Vented to exterior of building through relief valve.
- Expansion Joints Shall Be:
 - Hyspan series 3501 – externally pressurized.
 - Stainless steel body and travel arm.
- Condensate Pumps shall be:
 - Duplex electric pump style.
 - Cast-iron housing.

Part 3 – Execution

- Workmanship
 - Avoid direct - buried steam and condensate systems.
 - Steam trap and strainer shall be piped as an assembly with isolation valve and union at each end of the assembly.
 - Terminate relief valve vent lines outdoors in safe location - verify with U of A.
 - Use eccentric reducers in steam piping to assure level bottom.
 - Pitch steam and condensate piping downward in direction of flow at $\frac{1}{2}$ " per 10 ft.

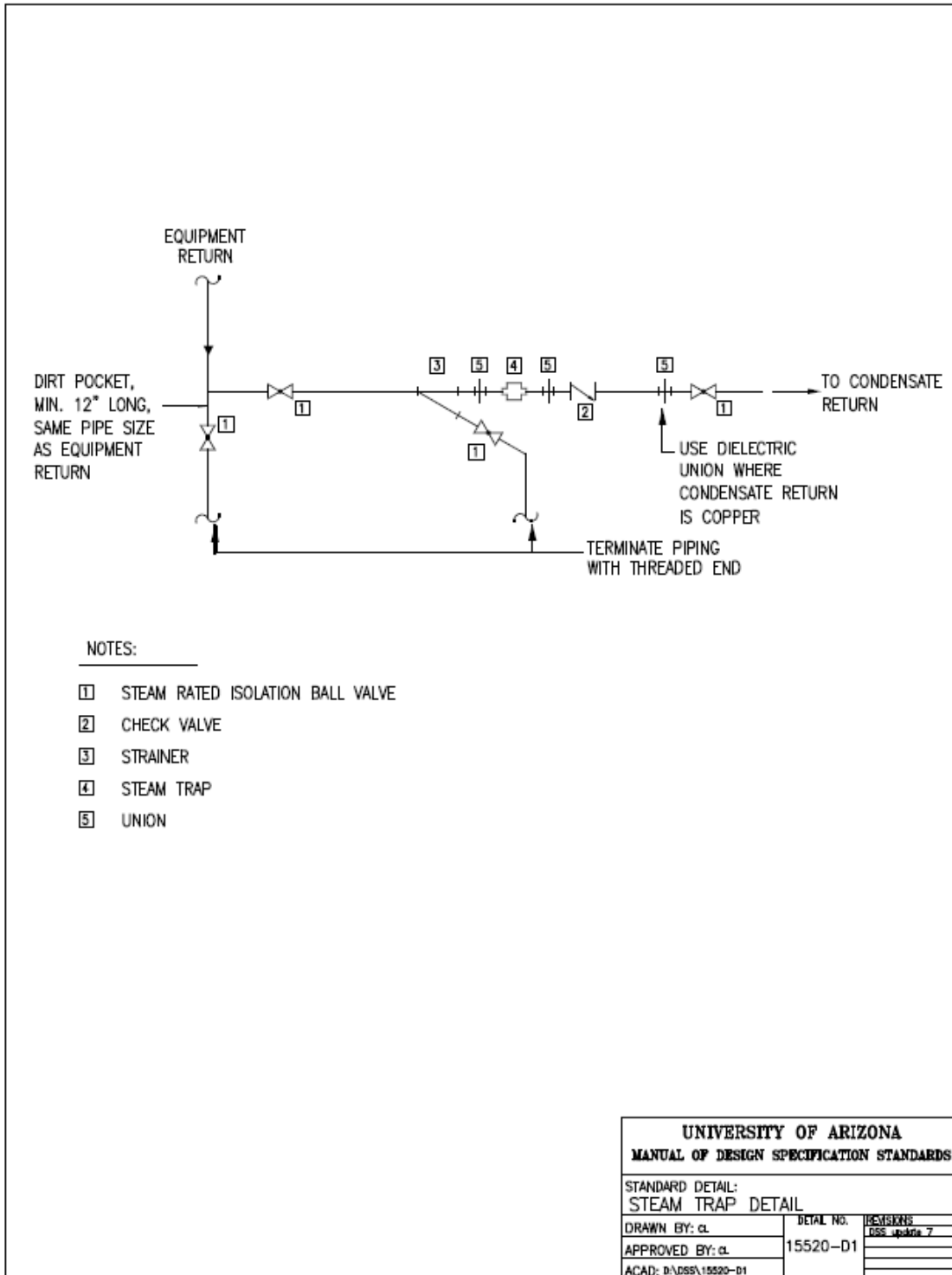

End of Section 15520

DIVISION 15 - MECHANICAL

Section 15530 - Refrigerant Piping and Specialties

Introduction

Piping and specialties associated with:

REFRIGERANT SYSTEMS

Part 1 - General

- Do not use pre-charged line sets (e.g. Aero Equip.)

Part 2 - Products

- Pipe Schedule - Above grade

<u>Service</u>	<u>Size</u>	<u>Pipe</u>	<u>Fittings</u>	<u>Joints</u>
Refrigerant Piping	All	Type 'L' ACR	Wrought Copper Or Cast Brass	15% Silver Solder Brazed

- Pipe Schedule - below grade

<u>Service</u>	<u>Size</u>	<u>Pipe</u>	<u>Fittings</u>	<u>Joints</u>
Refrigerant Piping	All	Type "K" ACR	Wrought Copper or Cast Brass	15% Silver Solder Brazed

- Use long radius fittings only

Part 3 - Execution

- Workmanship
 - Install per ASHRAE standards
- Installation
 - Provide isolation valves between split system components.
 - Provide nitrogen purge during soldering.
 - The U of A reserves the right to cut into any two fittings to confirm the use of nitrogen purge.
 - Support piping every 6 feet.
 - Provide line size trap every 25 feet of vertical lift.
 - Provide a liquid line filter drier before any expansion valve.
 - Provide suction line filter drier before compressor.
 - Provide Shraeder valves on suction and liquid line and across filter driers.

End of Section 15530

DIVISION 15 - MECHANICAL

Section 15540 - Heat Transfer Equipment

Introduction

Equipment associated with:

HVAC HEAT TRANSFER SYSTEMS INCLUDING: WATER COILS, PLATE AND FRAME HEAT EXCHANGERS, COOLING TOWERS, AND AIR WASHERS.

Pumping equipment including the following types: vertical in-line circulating pumps, base mounted pumps.

Part 1 - General

- Discuss heat exchanger type selection with UA Planning Design & Construction. Plate frame heat exchangers are **not** to be used for steam / water applications.
- Design to account for water fouling factor in equipment selection.
- See water treatment section for related requirements.
- Coil Section
 - Select cooling towers at 76°F wb ambient.
 - Consider high dewpoint outside conditions when sizing cooling coils.
 - Select cooling coils with water temperatures of 44°F EWT/62°F LWT (summer) and 50°F EWT/62°F LWT (winter). Differential pressure: 15 ft. minimum, 50 ft maximum.
 - Select heating coils with a 42°F water temperature differential.
 - Maximum coil face velocity 400 fpm.
 - Maximum coil air pressure drop 0.5" SP.
- Vertical in-line pumps are preferred with one pump as standby for building systems. Avoid base mounted pumps when possible.
- Use premium efficiency motors. See Section 15050.
- Evaporative cooling in AHUs shall be accomplished by fixed cell Munters Fill Glasdek. Do not use water wheels.
- Adequate space and provisions shall be left for removal of coils and servicing of equipment, with minimum inconvenience to the operation of systems.

Part 2 - Products

- Hydronic coils
 - To have bottom water supply and top return.
 - Use 5/8" minimum coil tube size.
- Vertical In-Line Pumps:
 - Preferred manufacturers; Grundfos, Bell & Gossett, Armstrong, Taco, Paco, Scott

Part 3 - Execution

- Provide full port ball type isolation valves close to equipment.
- Provide single pressure gauge indication with pressure snubber for each system component.
- Provide thermometer temperature indication for each line of each component.
- Provide Weld-o-lets installed for future monitoring on each line.
- Provide system strainers on inlet water side(s) of all coils and plate and frame heat exchangers.
- Coils shall be piped with water counterflow to coils. See coil detail.
- Comply with manufacturer's recommended free air space for cooling towers.
- Provide manufacturer recommended clearances for maintainability.
- Provide coil and heat exchanger blowdown sized at 1/3 of pipe size but not less than 1/2" on all sides of heat exchangers with full port ball valve. (See attached diagram)
- Provide air vent on return pipe near high point with manual air vent (1/2" ball valve minimum) for all coils and heat exchangers.

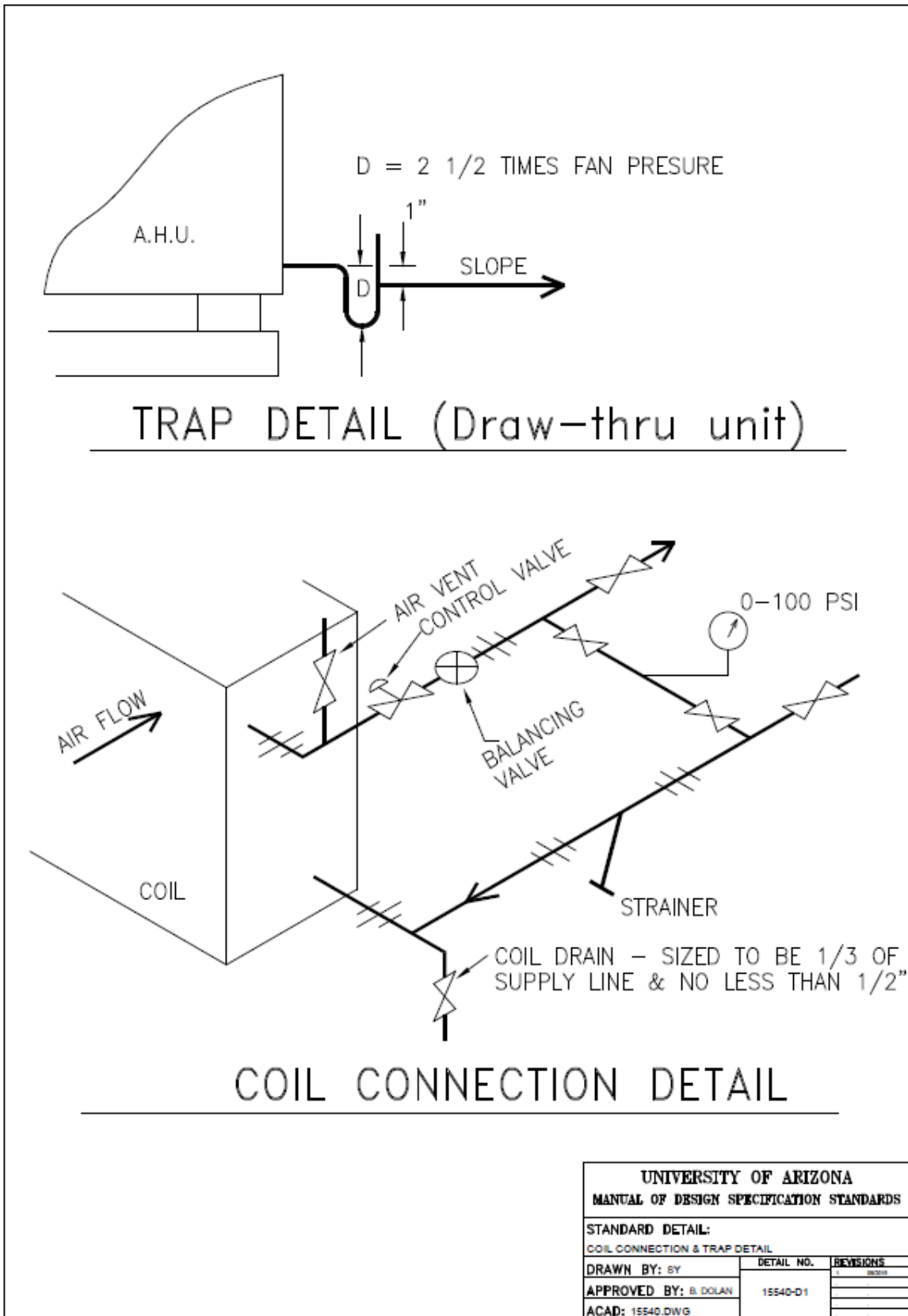

End of Section 15540

DIVISION 15 - MECHANICAL

Section 15550 - Heat Generation

Introduction

Heat generation equipment including:

BOILERS, FURNACES, FUEL FIRED HEATERS – Discuss all proposed installations with UA Planning, Design & Construction.

Part 1 - General

- Campus Buildings shall use steam as a source of heat – The need for heat generation equipment must be approved by the U of A.
- Boilers, furnaces and fuel fired heaters shall be natural gas.
- Provide equipment schedule and piping schematics for installation of boilers, furnaces, and fuel fired heaters.
- Provide access for service of equipment in accordance with code and manufacturer recommendations.
- Outside air reset shall be: 80°F water when outside air is 80°F, to 140°F water when outside air is 30°F.

Part 2 - Products

- Boilers
 - Preferred manufacturers are Parker and Weil McLain.
 - Boiler shall be a packaged unit with a minimum efficiency of 85%.
 - Boilers shall come with low water cutoff (manual reset), dual aquastat high limit control with manual reset, remote aquastat, outside air reset, gas cock, gas pressure regulator, 100% flame safeguard with manual reset, control panel.
- Furnace
 - Preferred manufacturers are Carrier, Rheem, and Trane.
 - Furnace shall be a packaged unit with an efficiency of more than 80%.
 - Furnace shall come with control relay for air conditioning.
 - Furnace shall come with high static pressure blower.
 - Heat exchangers shall have a minimum of 20 year warranty.

Part 3 - Execution

- Provide temperature and pressure gauges, and expansion tank for boilers.

End of Section 15550

DIVISION 15 - MECHANICAL

Section 15680 - Packaged Liquid Chillers

Introduction

Air and water cooled chillers up to 100 tons – Discuss all proposed installations with UA Planning Design & Construction.

Part 1 - General

- Equipment room - design room within existing codes, EPA regulations and ASHRAE design standards, in particular ASHRAE 15 including the separation of refrigerant and combustion equipment and provision of alarms.

Part 2 - Products

- Acceptable manufacturers: Trane, Carrier, York, McQuay.
- Unit Description
 - Liquid chillers can be semi hermetic or scroll compression design. Separate refrigerant circuits shall include the following: liquid line solenoid valve, filter dryer, sight glass, thermostatic expansion valve and service valves.
 - Unit efficiency shall meet ASHRAE 90.1
- Evaporator
 - Shell and tube design manufactured in accordance with ASME standard, fully insulated and equipped with a drain connection.
- Condensers
 - Copper tube aluminum fin pressure tested to ASHRAE standards. Provide head pressure control.
- Electrical
 - All electric installations shall comply with the latest NEC standard. Include motor starters with equipment.
- Controls
 - All equipment shall be complete with leaving water control and unloading capability, low/high pressure switches, low ambient, freeze stat, flow switch and motor overload safeties, low oil pressure safety switches.
- Receivers
 - Shall be capable of entire refrigerant charge pumpdown.
- Head Pressure / Load Control
 - Shall be capable of running in low load and low ambient conditions. Provide compressor cylinder unloading where applicable.

- Refrigerant
 - Use HFC refrigerants. Do not use CFC or HCFC.

Part 3 - Execution

- Remote Interface - provide interface with building/campus energy management system for alarms, start/stop, status, water temperatures.
- All systems are to be dehydrated, leak tested charged and tested for proper control and operation.

End of Section 15680

DIVISION 15 - MECHANICAL

Section 15780 - Packaged Air Conditioners

Introduction

Equipment associated with air conditioning systems including:

PACKAGED ROOFTOP AIR CONDITIONERS; SPLIT SYSTEM AIR CONDITIONERS; SINGLE PACKAGE HEAT PUMP; GAS/ELECTRIC AIR CONDITIONERS.

Part 1 - General

- All equipment shall comply with ASHRAE 90.1
- Packaged units shall be 100% factory run tested and fully charged.
- Cooling capacity ratings shall be based upon ARI and DOE test requirements.
- Size condensers for 115°F ambient temperature.
- Size evaporators for 80°F db/67°F wb indoor conditions unless Project requirements are different.
- Provide filters with a MERV of 8 or higher.

Part 2 - Products

- Heat Pumps
 - Provide minimum of 5kW strip heat for defrost mode where applicable.
- Roof Top Units
 - Provide filters in return ductwork or return grilles.
 - Maximum filter face velocity shall not exceed 400 fpm.
- Fans and Motors
 - Where available, specify belt driven fans with adjustable motor sheaves.
 - Use permanent split capacitor EPAC premium motors. See Section 15050.
- Gas Fired Heating Sections
 - Minimum of 20 year warranty.

Part 3 - Execution

- Install per manufacturer stated clearances.
- Condenser clearances to obstructions to be a minimum of 2 feet or as per manufacturer recommendations.
- Provide 3 feet clearance around rooftop units or remote condensing units.
- Provide maintenance access to all equipment requiring service.

End of Section 15780

DIVISION 15 - MECHANICAL

Section 15810 - Humidifiers

Introduction

Equipment associated with air conditioning equipment.

Part 1 - General

- Provide only when absolutely necessary or when a special Project requirement.
- Discuss with UA Planning Design & Construction before specifying.

End of Section 15810

DIVISION 15 - MECHANICAL

Section 15840 - Ductwork

Introduction

Ductwork Systems including:

METAL DUCTWORK, FLEXIBLE DUCTWORK, EXHAUST DUCTWORK.

Part 1 - General

- All exhaust ductwork within the building shall be under negative pressure. Exhaust ductwork connections to equipment shall allow for proper drainage flow. Fumehood exhaust ductwork can be manifolded only if multiple exhaust fans are used.
- Special applications of products other than those listed must be submitted to the University for consideration.
- Restrict use of duct liner as per Section 15250 requirements.
- Ductwork downstream of air handling units shall be constructed in accordance with 100% effective duct length as per ASHRAE and latest SMACNA standards.
- Chemical exhaust ductwork to conform with ANSI/AIHA standard 29.5 - 1992
- Ductwork to be constructed per latest SMACNA HVAC Duct Construction Standards.
- Exhaust system designs shall conform to AIHA Industrial Ventilation manual.

Part 2 - Products

- Galvanized Steel shall be ASTM A 527, G90 of lock forming quality.
 - Heating & cooling supply and return, non-chemical exhausts – minimum 24 gauge.
- Stainless Steel shall be ASTM A 240, type 316
 - Spiral or welded for fumehood applications. Fittings shall be continuously welded – liquid tight.
 - All welded seams for perchloric applications.
- Coated Galvanized Steel
 - Under special circumstances, with University permission, coated galvanized steel ducts may be used for manifolded general chemical exhaust plenums which are large enough to allow duct internal inspection and repair of coating.
- Flexible Ductwork
 - All flexible ductwork applications to be “Thermafex M-KC” or approved equal.
 - Ductwork to be constructed in accordance with NFPA 90A, 90B, UL181 Class 1.

Part 3 - Execution

- High pressure flexible ductwork shall not be used for changes in direction.

- Low pressure flexible ductwork may only be used to accommodate a total of a 45° change in direction. Hard elbows shall be used at diffusers.
- Flexible ductwork shall be secured utilizing steel draw-band clamp.
- Maximum flexible ductwork lengths - 18" on high pressure systems, 48" on low pressure systems.
- Use center radius of 1.5 times duct width (minimum) on tees, bends, elbows.
- Use Hardcast AFG-1402 Foil-Grip tape, Hardcast DT-Tape with FTA-20 adhesive, or water based paint-on duct sealant for indoor use, or RTA-50 adhesive for outdoor use, to seal all duct joints.
- Ductwork shall be stored in a clean location prior to installation. Openings shall be covered to prevent entry of dust, moisture and general construction dirt/debris. Plastic sheeting securely taped over open ends will be acceptable.
- Provide balancing dampers at all branch ducts.
- Use single thickness turning vanes only in ductwork up to 2" pressure class. Install per SMACNA.
- Do not use turning vanes in reducing elbows.
- Utilize 45° branch duct entries with main duct size reduction downstream for medium and high velocity systems.
- Utilize 45° branch duct entries or full conical taps for low pressure ductwork. No Bellmouth, Flanged or Notch Spin-In connections permitted except at terminal/diffuser take-offs.
- No extractors allowed.
- Design with 15° convergence and divergence preferred. Absolute maximum of 30° divergence or 45° convergence.
- Use Pittsburg construction on longitudinal seams. Button punch snaplock construction is not acceptable.

End of Section 15840

DIVISION 15 - MECHANICAL

Section 15850 - Ductwork Accessories

Introduction

Equipment associated with:

AIR HANDLING SYSTEMS INCLUDING TERMINAL BOXES

Part 1 - General

- Terminal Box test submittal data shall be in accordance with ADC/ARI Standard 880.
- Terminal Box controllers to be compatible with Campus EMCS. (See Section 15970)

Part 2 - Products

- All Terminal units to be electric/electronic type.
- Use only 'long' terminal boxes for any air volume control application requiring accuracy greater than +/- 25%.
- Minimum press drop across Terminal Box to be 0.1" wg with control damper fully open.
- Terminal Boxes shall have screwed access doors if serviceable items are enclosed.
- Do not reuse existing Terminal Boxes when designing a space remodel.
- Terminal Box damper leakage shall not exceed 2% of nominal box rating at 4" static pressure.
- All Terminal Box controls shall be externally mounted.

Part 3 - Execution

- Install terminal boxes with minimum of 18" clearance access for service and maintenance.
- Fire dampers to be installed in accordance with manufacturers installation instructions.

End of Section 15850

DIVISION 15 - MECHANICAL

Section 15855 - Air Handling Systems

Introduction

Equipment associated with:

CENTRAL STATION AIR CONDITIONING AND DISTRIBUTION.

See related Sections:

15540 Heat Transfer Equipment
15860 Fans
15885 Filters

Part 1 - General

- Preferred system design based on Dual Duct VAV Concept complete with dual fans. Alternative systems must be justified by life cycle cost analysis. Discuss all system selections with UA Planning, Design & Construction.
- AHU to be 'draw-thru' type.
- Preferred location of OA intakes is above roof level - not ground level. However, avoid location of AHU outside air intake in vicinity of plumbing vent stacks, emergency generator stacks and loading dock areas.
- OA intakes to be hard ducted through Mech. Rooms unless a separate AHU room is provided.
- Equipment layout shall minimize / eliminate any system effect on fan static pressure.

Part 2 - Products

- Provide hinged access doors to both sides of coils, fans, filters and damper sections.
- Provide removable side panels in fan sections to allow for fan and shaft removal/replacement.
- AHU shall not be constructed using porous or semi porous materials.
- AHU shall be double walled casing - minimum 18 gauge.
- AHU shall have interior inspection lights.
- Large AHU to have inspection windows in access doors.
- Utilize only 'premium efficiency' motors in AHU's. See Section 15050.
- AHU should be designed to minimize the number of field connections between sections.

Part 3 - Execution

- Ensure coil drain pans and condensate pipework is pitched to drain, (minimum pitch ¼" per foot).
- In new construction utilize AHU to 'flush' building to reduce off-gassing of interior furnishings prior to occupancy. Fit AHU with temporary filters during this period.
- Replace filters before system balancing.

- Provide vibration safety switches on all Vane Axial type fans.
- Provide suitable access for servicing/removal of fan assemblies.
- Control valves shall be located outside of air handler enclosure. (i.e. not within the airstream)
- Ensure access is provided to both sides of AHU fans to allow bearing replacement.
- Factory leak tests and sound tests are required.

End of Section 15855

DIVISION 15 - MECHANICAL

Section 15860 - Fans

Introduction

Fan systems including:

SUPPLY, RETURN AND EXHAUST AIR SYSTEMS.

Part 1 - General

- Don't use VFDs on forward curved fans.

Part 2 - Products

- Preferred manufacturers; Greenheck, Loren Cook, ILG, Trane.
- Short coupled, multi-belted fans to utilize companion sheaves in lieu of variable pitched sheaves.
- Provide vibration switch on fan.
- Max RPM for exhaust fans not to exceed 1800.
- Fans to be tested in accordance with ANSI/ASHRAE STD 51 and ANSI/AMCA STD 210.
- Centrifugal fans handling more than 1,000 CFM shall have backward inclined blades.
- Fans shall be statically and dynamically balanced at the factory.
- Standard Products - use same manufacturer for multiple installations for the same type.
- Permanently lubricated bearings are not acceptable on 10HP or larger drives.
- Bearings shall be heavy duty split pillow block, self-aligning ball bearings with seals and grease nipples, minimum service life of 200,000 hrs.
- Provide drain connection in bottom of exhaust fan housing - minimum size 3/4".
- Provide access doors on housing- minimum size 18" x 18".
- Provide weather-proof package for any fan located outdoors.
- Utility fans serving fume hoods shall have minimum velocity of 3000 fpm. at stack discharge. Min. height of discharge stack to be 10'.

Part 3 - Execution

- No discussion.

End of Section 15860

DIVISION 15 - MECHANICAL

Section 15870 – Variable Frequency Drives

Introduction

This specification is to cover a complete variable frequency motor drive (VFD) consisting of a pulse width modulated (PWM) inverter output waveform (VVI, six-step, and current source drives are not acceptable) designed for use on a standard NEMA Design B induction motor. The VFD shall employ a 1600 volt full wave bridge rectifier, 5% impedance AC or DC Line Reactor, EMI/ RFI filters, capacitors, and Insulated Gate Bipolar Transistors (IGBT's) as the output switching device.

The drive manufacturer shall have a representative exclusively for HVAC products, both sales and service will be the same organization for sole source responsibility.

Part 1 - General

- Quality Assurance
 - Referenced Standards
 - Institute of Electrical and Electronic Engineers (IEEE) Standard 519-1992, IEEE Guide for Harmonic Content and Control.
 - Underwriter Laboratories: UL508C
 - National Electrical Manufacturer's Association (NEMA) ICS 7.0, AC Adjustable Speed Drives.
 - IEC 16800 Parts 1 and 2.
 - Qualifications
 - VFD's and options shall be UL listed as a complete assembly. VFD's that require the customer to supply external fuses for the VFD to UL listed are not acceptable. The base VFD shall be UL listed for 100 KAIC without the need for input fuses.
 - CE Mark- European Union Electro Magnetic Compatibility directive, a requirement for CE marking. The VFD shall meet product standard EN 61800-3 for the First Environment restricted level.
 - Acceptable Manufactures- ABB ACH Series, 550.
 - Substitutions must have written approval by the Design professional 2 weeks prior to date of bid. Written approval does not relieve supplier of specification requirements. All exceptions to this specification shall be submitted in writing to the Consulting Engineer at that time.
 - All VFD's shall be provided by the authorized local Rep/Distributor and be of one manufacturer. All HVAC OEM'S (AHU, Pumps, Cooling towers, etc.) shall allow VFD's to be shipped to factory for mounting or HVAC OEM units are to be deigned to interface/accommodate field mounting of VFD's.
 - All VFD's that are manufactured by a third party and "brand labeled" shall not be acceptable.
- Submittals
 - Submittals shall include the following information:
 - Outline dimensions, conduit entry locations and weight, customer connection and power wiring diagrams, technical product description include a complete list of options provided.
 - Compliance to IEEE 519- harmonic analysis for particular jobsite including total harmonic distortion (BOTH VOLTAGE and TDD). Using job specific electrical information the VFD manufacturer shall provide calculations showing total harmonic voltage distortion, is less than 5% at point of common coupling. Input line filters shall be sized and provided as required by the VFD manufacturer to ensure compliance with IEEE standard 519. All VFD's shall include a minimum of 5 % impedance reactors, **no exceptions**.

Part 2 – Products

- Variable Frequency Drive
 - The VFD shall be listed ISO9001 and the package as specified herein shall be enclosed in a UL listed Type 1, 12 (indoor enclosures) or 3R (outdoor enclosure) as applicable/specified.
 - The VFD tolerated voltage window shall allow the VFD to operate from a line of +30% nominal, and -35% nominal voltage as a minimum.
 - Environmental operating conditions: -15 to 40°C to (5 to 104°F) ambient temperature continuous with no current de-rate. From 40°C (104°F) to 50°C (122°F) ambient temperature range, VFD current de-rate will not be greater than 10% and not exceed a rate of 1% current de-rate per 1°C or VFD must be oversized. VFD's that can operate at 40°C intermittently (during a 24 hour period) are not acceptable and must be oversized. Altitude 0 to 3300 feet above sea level, less than 95% humidity, non-condensing. Enclosure shall be UL listed as a plenum rated VFD. VFD's without these ratings are not acceptable.
 - All VFD's shall have the following standard features:
 - All VFD's shall have the same digital keypad, shall be removable, capable of remote mounting and uploading and downloading of parameter settings for start-up of multiple VFD's.
 - The keypad shall include Hand-Off-Auto selections and manual speed control. The drive shall incorporate "bumpless transfer" of speed reference when switching between "Hand" and "Auto" modes.
 - There shall be a built-in time clock in the VFD keypad. The clock shall have a battery back up with 10 years minimum life span. The clock shall be used to date and time stamp faults and record operating parameters at the time of fault. The clock shall also be programmable to control start/stop functions, constant speeds, PID parameter sets and output relays, four (4) separate, independent timer functions that have both weekday and weekend settings.
 - The VFD's shall utilize pre-programmed HVAC application macro's specifically designed to facilitate start-up.
 - The VFD shall have cooling fans designed for replacement without requiring removing the VFD from the wall or removal of circuit boards.
 - The VFD shall be capable of starting into a coasting load (forward or reverse) up to full speed and accelerate or decelerate to setpoint without safety tripping or component damage (flying start).
 - The VFD shall automatically restart after an over-current, over-voltage, under-voltage, or loss of input signal.
 - The overload rating of the drive shall be 110% of its normal duty current rating for 1 minute every 10 minutes, 130% overload for 2 seconds. The minimum FLA rating shall meet or exceed the values in the NEC/UL table 430-150 for 4-pole motors.
 - The VFD shall have integral 5% impedance line reactors to reduce the harmonics to the power line and to add protection from AC line transients. The 5% impedance may be from dual (positive and negative DC bus) reactors, or 5% impedance AC line reactors. VFD's with only one 5% DC reactor shall add AC line reactors.
 - The VFD shall include a coordinated AC transient protection system consisting of 4-120 joule rated MOV's (phase to phase and phase to ground), a capacitor clamp, and 5% impedance reactors.
 - The VFD shall be capable of sensing a loss of load (broken belt/broken coupling) and signal a warning or fault as required.
 - If there is a loss of the input reference the VFD shall give the user the option of either(1) stopping and displaying a fault, (2) running at a programmable preset speed, (3) hold the VFD speed based on the last good reference received, or (4) cause a warning to be issued, as selected by the user.
 - All VFD's shall have the following adjustments:
 - Three (3) programmable critical frequency lockout ranges to prevent the VFD from operating the load continuously at an unstable speed.
 - Two (2) PID setpoint controllers shall be standard in the drive, using the microprocessor for the closed loop control. The VFD shall have 250 ma of 24 VDC auxiliary power and be capable of loop

powering a transmitter supplied by others. The PID setpoint shall be adjustable from the VFD keypad, analog inputs, or over the communications bus. The PID parameter values may be changed with a digital input, serial communications or from the keypad. There shall be an independent, second PID loop that can utilize the second analog input and modulate one of the analog outputs to maintain setpoint of an independent process (i.e. valves, dampers, cooling tower bypass valve control, chilled water valve control, etc.) and be accessible from the serial communication network. The setpoints shall be available in engineering units.

- Two (2) programmable analog inputs shall accept current or voltage signals.
 - Two (2) programmable analog outputs. (0-20ma or 4-20ma)
 - Six (6) programmable digital inputs allowing multiple safeties, run permissive circuits for damper and valve control, etc.
 - The VFD shall include a “run permissive circuit” that will provide a normally open contact whenever a run command is provided (local or remote start command in VFD or bypass mode). The VFD shall provide a dry contact closure that will signal the damper to open (VFD motor does not operate). The VFD system (VFD or bypass) shall not operate the motor until it receives a dry contact closure from a damper or valve end-switch. When the VFD system safety interlock (fire detector, freezestat, high static pressure switch, etc) opens, the motor shall coast to a stop and the run permissive contact shall open, closing the damper or valve.
 - Three (3) programmable digital Form-C relay outputs standard, expandable to (6). The relays shall include programmable on and off delay times and adjustable hysteresis. The relays shall be rated for maximum switching current 8 amps at 24 VDC or 250 VAC. Maximum voltage 30 VDC and 250 VAC with maximum continuous current rating 2 amps RMS. Outputs shall be true from C type contacts; open collector outputs are not acceptable.
 - Seven (7) programmable preset speeds.
 - The VFD shall include a motor flux optimization circuit that will automatically reduce applied motor voltage to the motor to optimize energy consumption and audible motor noise.
 - The VFD shall reduce the carrier frequency on actual VFD temperature that allows highest carrier frequency without derating the VFD.
 - The VFD shall include password protection against parameter changes.
- The Keypad shall include a backlit LCD display be in complete English words for programming and fault diagnostics (alpha-numeric codes are not acceptable).
 - All applicable operating values shall be capable of being displayed in engineering (user) units. A minimum of three selectable values will be displayed in real time, in complete English words.
 - The VFD shall include a fireman’s override input. Upon receipt of a contact closure from the fireman’s control station, the VFD shall override all other inputs (analog/digital, serial communication, and all keypad commands) and force the motor to run at the adjustable, preset speed.
 - Serial Communications
 - The VFD shall have an RS-485 port as standard. The standard protocols shall be Modbus RTU, Johnson Controls N2 bus, Siemens Building Technologies FLN and BACnet available. No additional hardware, firmware, gateways, etc. shall be required for these standard protocols. Optional protocols for Lon Works, Profibus, Ethernet, and DeviceNet shall be available, and have the protocol in each VFD. The use of third party gateways and multiplexers is not acceptable. All protocols shall be “certified” by the governing authority, non-certified protocols are not allowed. If additional gateway, hardware, etc. is required to obtain the BACnet, Modbus, etc. interfaces, the VFD manufacturer shall supply one gateway, hardware device, etc. per VFD. Multiple VFD’s sharing one gateway, hardware, etc. shall not be acceptable.
 - The BACnet connection shall be an RS485, MSTP interface operating at 9.6, 19.2, 38.4 or 76.8Kbps. The connection shall be tested by the BACnet Testing Labs (BTL) and be BTL listed. The BACnet interface shall conform to the BACnet standard device type of an Applications Specific Controller (B-ASC). The interface shall support all BIBBS (BACnet Interoperability Building Blocks) defined by the BACnet standard profile for a B-ASC.
 - The drive shall have the capability of allowing the DDC (Direct Digital Control/ Building Automation

System) to monitor feedback, such as process variable feedback, output speed/ frequency, etc. monitoring the VFD relay output status, digital input status, and all analog input and analog output values. All diagnostic warning and fault information, remote VFD fault reset keypad “Hand” or “Auto” selected, bypass selected, the ability to change the PID setpoint, and the ability to force the unit to bypass(if bypass is specified) shall be transmitted over the serial communications bus. The DDC system shall also be able to monitor and start stop if the motor is running in the VFD mode or bypass mode. (if bypass mode is specified)

- The VFD shall allow the DDC to control the drive’s digital and analog, inputs and outputs. For example, the analog outputs may be used to modulating chilled water valves or cooling tower bypass valves, digital (relay) outputs may be used to actuate a damper, open a valve or control any other device that requires a maintained contact for operation.
- EMI/RFI filters. All VFD’s shall include EMI/RFI filters. The onboard filters shall allow the VFD assembly to be CE Marked and the VFD shall meet product standard EN 61800-3 for the First Environment restricted level.
- Bypass – All features shall be UL listed by the drive manufacturer as a complete assembly and carry a UL508 label.
 - An output contactor, bypass, contactor and VFD only disconnect/service switch and/or fuses. Overload protection and shall be provided in both drive and bypass modes.
 - Door inter-locked, pad-lockable circuit breaker that will disconnect all input power from the drive and all internally mounted options.
 - Fused VFD only disconnect (service switch) and/or fast acting fuses exclusive to the VFD to allow the VFD to disconnect from the line prior to clearing upstream branch circuit protection, maintaining bypass capability. Bypass designs that incorporate fuses common to both the VFD and the bypass will not be accepted. Three contactor by pass schemes are not acceptable, as a VFD input contactor is not a NEC recognized, lockable, physical disconnect and is an unacceptable means of safely disconnecting power to VFD.
 - The drive/ bypass shall provide single-phase motor protection and under-voltage protection in both the VFD and bypass modes.
 - The following operators shall be provided: a. Bypass Hand-Off Auto; b. Drive mode selector; c. Bypass mode selector; d. Bypass fault reset.
 - The following indicating lights (LED type/ pilot light) shall be provided. A test mode or push to test feature shall be provided: a. Power-on (Ready); b. Run enable (safeties) open; c. Drive mode select damper opening; d. Bypass mode selected; e. Drive running; f. Bypass running; g. Drive fault; h. Bypass fault; i. Bypass H-O-A mode; j. Automatic transfer to bypass selected; k. Safety open; l. Damper open; m. Damper end-switch made.
 - The following relay (form C) outputs from the bypass shall be provided: a. System started; b. System running; c. Bypass override enabled; d. Drive fault; e. Bypass fault motor overload or underload (broken belt); f. Bypass H-O-A position.
 - Customer Interlock Terminal Strip for connection of freeze, fire, smoke contacts, and external start command. The remote start/stop contact shall operate in VFD and bypass modes.
 - Dedicated digital input that will transfer motor from VFD mode to bypass mode upon dry contact closure for fireman’s override. Two modes of operation are required.
 - One mode forces the motor to bypass operation.
 - The second fireman’s override mode remains as above but will also defeat all safeties and inputs (run until destruction).
 - Class 20 or 30 (selectable) electronic motor overload protection shall be included.
 - Provide capability to select manual or automatic bypass.

Part 3- Execution

- Installation
 - Installation shall be the responsibility of the mechanical contractor as outlined in the installation manual.
 - Power wiring shall be completed by the electrical contractor as outlined in the installation manual.

- Start-Up
 - Certified factory start-up shall be provided for each drive by a factory authorized service center. A certified start-up form shall be filled out for each drive with a copy provided to the owner, and copy kept on file at the manufacturer.
- Product Support
 - Factory trained application engineering and service personnel shall be locally available at both the specifying and installation locations. A 24/365 (24 hour/ 365 days per year) technical support line shall be available on a toll- free line.
 - A computer based training CD and 4 hour on-site training shall include installation, programming, and operation of the VFD, bypass and serial communication.
- Warranty
 - Warranty shall be 24 months from the date of substantial completion. The warranty shall include all parts, labor, travel time and expenses. There shall be 24/365 support available via a toll free phone number.

End of Section 15870

Division 15 Mechanical

Section 15970 - Control Systems

Introduction

Equipment associated with:

THE MANAGEMENT OF HEATING, VENTILATION, AND AIR CONDITIONING RELATED UTILITIES.

Part 1 - General

- The Energy Management Control System (EMCS) shall be Direct Digital Control, fully automatic, with electric and electronic components as required. All actuation within mechanical rooms and major air handling units shall be electric/electronic. Discuss with the University if pneumatic controls are being proposed.
- All terminal boxes, sensors and actuators shall be electronic/electric.
- System design shall be capable of Stand-Alone operation, defined as operating the equipment in a safe manner even when completely disconnected from the rest of the network. This mode of operation may not be able to achieve all aspects of the sequence of operation (SOO), but it shall still operate the equipment under a basic control scheme achievable with the local inputs and outputs available to the controller while operating under stand-alone circumstances. An alarm shall always be generated and sent to the EMCS monitoring system operator(s) when a controller is not connected to the network.
- System design shall be modular to ensure future expansion capabilities, whether it be additional control/monitoring points or supervisory functions.
- System shall have a minimum of 10% capacity expansion within the current equipment.
- Monitor all central utilities and emergency systems from a local and remote location.
- Metering devices to be installed per design guidelines Section 15980.
- Provide electronic speed control for variable volume systems.
- All controllers on new building projects must be native BACnet: BACnet compliant and BTL-certified (ASHRAE Standard 135-2012). Exceptions only with University approval. If the project is within an existing building, the communication protocol may match existing, pending University approval.

Part 2 - Products

- The EMCS shall consist of high-speed, peer-to-peer network of native BACnet DDC controllers and Niagara^{AX} Network manager(s) (Niagara^{AX} JACE). Discuss JACE size with the University.
- The building controls interface shall be web-based. Access to the building network manager (Niagara^{AX} JACE) shall be accommodated via an embedded web server. Control system access shall not require special operator software for web browser access.
- The direct digital control system shall be directly connected to the Owner's campus-wide EMCS via an IP network connection to campus control network. Coordination with University of Arizona Facilities IT is required to obtain network connectivity and configuration information.
- BACnet communications protocol will be utilized on the dedicated building communication network between EMCS controllers and other BACnet devices to assure interoperability between all devices within the building network. BACnet/IP shall be used for major equipment controllers, while BACnet MS/TP will be acceptable for minor equipment (such as terminal units, individual zone controls, etc.). BACnet/Ethernet shall be disabled on

any device capable of supporting this protocol. Coordination with University of Arizona Facilities IT is required to obtain BACnet network connectivity and configuration information.

- The EMCS shall provide the direct integration of standard BACnet/IP and Modbus TCP protocols. LonWorks/LonTalk protocol shall be supported where applicable.
- The EMCS shall provide BACnet/IP communication in compliance with the ASHRAE Standard 135 Annex J. All B-BC and B-AAC controllers, as well as any BACnet gateways used (by specific University of Arizona permission only), must be BACnet/IP. B-ASC, B-SA, and B-SS controllers may be BACnet MS/TP.
- All software shall be latest version available at the date of substantial completion.
- Noise, surge and spike protection: Kele model # HSP-121-B
- Shall be capable of withstanding power outages and surges for extended periods of time.
- Memories shall be non-volatile, or unit shall hold memory up to 30 days minimum on backup batteries.
- All CV and VAV terminal unit controls shall be DDC application specific type for new building construction (B-ASC).
- Use Fisher 92B steam pressure reducing valve with the appropriate pilot.
- Use manual reset freeze stats.
- Humidity sensors: OMEGA-HX-93C.
- Siemens, Alerton, Automated Logic, Delta Controls, Trane, Distech, Honeywell, and Schneider Electric all offer BACnet-compliant, BTL-certified controls products. Other manufacturers may also offer suitable products for use at University of Arizona. All Building Automation, Controls, or Energy Monitoring System products are subject to University of Arizona approval.

Part 3 - Execution

- Supply the following monitoring and control features where applicable:
 - Building Systems- Complete utility usage (water, Heating water, chilled water, electric) see section 15980 for additional requirements.
 - Utility Usage

Chilled water flow in GPM, totalized energy in BTU's.
Chilled water header differential pressure (psig).
Heating Hot water flow in GPM, totalized energy in BTU's.
Domestic Hot water flow in GPM totalized in Btu's.
Domestic water totalized in gallons.
Electric use totalized in kW hrs., real time demand in kW.
Individual equipment power and energy use where required by University of Arizona.
Chilled water supply and return pressure and temperatures.
Steam pressures.
Domestic water pressures.
Hot water supply and return pressure and temperatures.
Status of equipment pumps and drives.
Change of set point capability for all variable frequency drives.
Provide HVAC equipment greater than 1 HP with time scheduling capability, i.e., time clocks.
Reset of hot water supply temperatures.
Chiller operational status, run times, pressures and temperatures.

Cooling tower operational status and temperatures.
Report of any EMCS component failures on critical equipment as required by University of Arizona.
Emergency generator-run time, load, kW, kVA.
Alarms as specified in other sections.

- Individual Unit Characteristics

Air Handler status, start/stop.
Supply, Return and Mixed air temperatures.
Return Air humidity (expressed as dew point temperature).
Demand reset of hot and cold decks (based on zone terminal unit demand).
Economizer control (enthalpy).
Chilled water return temperature control.
Lighting controls where specified.
Occupancy reset of temperature and system shutdown (scheduled and/or via sensors).
Filter differential pressure indication.
Space humidity status and reset when specified,
High limit humidity control.(Dehumidification mode).
Status of Hot and Cold duct static pressure.
Demand reset of duct static pressure.
Active control strategy for maintaining outdoor air requirements, (e.g.: CO₂ sensing, flow measurement).

- Terminal Unit characteristics

Adjustment of flow set points (min and max).
Override of temperature setpoint.
Occupied and Unoccupied set points for flow and temperature.
Adjustable dead-band.
Discharge air temperature.
Valve position.
% cooling load.
%heating load.
Current flow setpoint.
Current airflow.

- Provide a single building outdoor air station that measures Temperature and Humidity. (This station will be used for all building reset and AHU mode decisions, i.e.: economizer, dehumidification.) This station must be installed on the North side of the facility out of direct sunlight in a location that will not be affected by influences other than actual ambient air conditions, such as exhaust air, radiant heat from nearby objects, reflected radiant heat, evaporation, vandalism, or other confounding factors.
- Dew point temperature is to be used for humidity control actions not relative humidity.
- Provide airflow measuring stations as required.
- All control valves and isolation valves are to be located outside the Air Handler enclosure (not in the airstream).
- Chilled water control valves to fail to “open” position. Hot water control valves to fail to “closed” position.
- Provide adequate space to install all control valves with stems in the vertical position without exception.
- Provide adjustable static pressure safety switch to shut down VFD controlled fans.
- Identify all controls and wiring within pertinent control panel and provide control system drawing framed under Plexiglass on inside of panel door.

- All Graphic screens to be submitted for review and approval by the University prior to installation.
- Contractor shall provide all software (including any licensing required), hardware (special cables, operator terminals, etc.), and administrator access privileges to allow full configuration, programming, and administration of all system components and devices provided.
- Contractor to provide one (1) week (forty hours) of factory-approved classroom training for a University Technician as part of their project scope. This training shall cover basic system operator topics, and shall include study materials suitable for use in cross-training other University Technicians. Submission of training materials is required in the submittal phase. Training is to be scheduled at the University's convenience.

End of Section 15970

DIVISION 15 - MECHANICAL

Section 15980 - UTILITY METERS

Introduction

Meters are required on chilled water, water (load) side of steam to water heat exchangers, and domestic water.

Part 1 - General

- Design, specify, furnish, install, and commission all utility meters required and owned by the University.
- Utility meters shall be designed and specified by the project Design Professional. Project contractor shall furnish and install all utility meters. Utility meter commissioning shall be a joint effort between the project contractor and the Design Professional and The University of Arizona. The University will not accept any utility meter until it has been shown to be fully functioning and operational.
- Design shall include selecting, scheduling, and specifying each utility meter as would be done for any piece of specialized equipment.
- Review the proposed metering scope with PDC Mechanical Engineer early in the project to confirm the campus wide requirements are being fulfilled. Projects that interface with existing building systems may require a different configuration.
- Flow Meters shall be selected to handle the flow range they will encounter at present design conditions.
- Meters shall be connected to the University's campus data collection system via a Niagara^{AX} JACE furnished with a BACnet server license.
- All meters shall be capable of fully monitoring the building energy and water usage.
 - The meter shall be selected with BACnet/IP or Modbus TCP output, or Modbus RTU.
 - All meters, transducers and RTD's will be non-intrusive.
 - Project control drawings and specifications shall include all the information, including, but not necessarily limited to, points, termination, and programming necessary to provide complete building energy use reporting on the University's EMCS in addition to the building EMCS (refer to section 15970).
 - Metering submittal shall include information specific to the product(s) being proposed. At minimum, the following product information shall be provided for any utility meter product:
 - Product technical specifications (data sheet or cut sheet)
 - Installation/wiring/configuration manual
 - Technical or programming manual/guide
 - Owner's manual or maintenance guide
 - Modbus technical information (including register map & data encoding)
 - Troubleshooting guide
 - IT hardening guide
 - University of Arizona shall assist in reviewing the project contractor's utility metering submittal.
 - Project drawings and specifications shall include the following utility meter information as a minimum:
 - Domestic Water, Chilled Water, and Heating system, Meters:
 - Type of service (i.e., chilled water, Heating, or domestic water).

- Size of meter, manufacturer, type, model number.
- Location of meter, sensors, and remote readouts.
- Meter shall be located, including dimensions of installation if a specific location is necessary for proper operation.
- Meter or meter remote readouts shall be readily accessible and at a level (5'6") that can be read without using a ladder.
- Complete network topology diagram detailing serial and IP network configuration including:
 - IP configuration information for IP devices
 - Modbus TCP
 - BACnet/IP
 - LonWorks/LonTalk over IP
 - Modbus RTU network configuration information for serial networks and Modbus devices (where applicable)
 - BACnet MS/TP network configuration information for serial networks and BACnet devices (where applicable)
 - LonWorks/LonTalk network configuration information for serial networks and Modbus devices (where applicable)
- Accuracy and Repeatability to meet federal guidelines for billable meter requirement.
- Domestic Water, Chilled Water, and Heating Water Meters:
 - Range: maximum flow, minimum flow, and normal flow expected at present design conditions.
 - Installation details: details shall be complete and include all necessary information, including, but not limited to, length of straight pipe required upstream and downstream, distance required from valves or fittings, any required concentric reducers and location of temperature and pressure sensors.
- Chilled Water and Heating water Meters:
 - All items necessary to allow the chilled water flow sensors to function as energy meters shall be specified and shown on the drawings and included in installation details.
 - Output of energy meter shall be in BTU's and totalized in MBTU's.
 - These additional items shall include, but are not limited to, temperature sensors, BTU totalizing computer, connection requirements to the campus SCADA C3 system at the Modbus gateway with a BACnet or Lon connection from the University EMCS system, programming requirements and software.
 - Delta-temperature transmitters shall be platinum 1000 OHM RTD, Where 1000 ohms equals 32°F.
 - Delta-temperature sensors shall be matched pairs of calibrated sensors with an accuracy of 0.12° F.
 - Flow transducers shall be selected for the expected flow range encountered at present design conditions, pipe size and material. Particular attention shall be made to low flow conditions; specified accuracy shall be maintained under low flow conditions.
 - For all installations an energy totalizing computer will be required.

Part 2 - Products (UTILITY METER REQUIREMENTS) – Discuss With UA Planning Design & Construction

- Domestic Water Meter:
 - Shall be clamp-on ultrasonic flow meter, Metron flow meter with 1180 series BUM, Siemens SITRANS FUS1010, or approved equal.
 - Meters shall read in gallons and totalized in KGAL.
 - Water meters shall have a local readout as well as Modbus output to report to the Campus SCADA C3 system and thru a BACnet or Lon connection from the Modbus Gateway to the University's EMCS system.
- Chilled Water and Heating water flow sensor:

- Shall be clamp-on ultrasonic energy meter, Metron flow meter with 1180 series BUM, Siemens SITRANS FUE1010, or approved equal.
- Where an energy totalizing computer is required, it will use the Modbus protocol for output. Modbus TCP is preferred, while Modbus RTU is acceptable.
- Flow transducers shall be combined with supply and return temperature sensors.
- Transducers and temperature RTD's will be factory calibrated matched sets.
- Meters shall be capable of local or remote reading within the building close to the meter location.
- Provide a Modbus TCP output or Modbus RTU output to the Campus SCADA C3 system Modbus gateway; from the Modbus gateway provide a BACnet or Lon connection to the University's EMCS.

Part 3 – Execution

- Include energy meter data on the graphic screen as part of the building EMCS in addition to the connection to the university's campus wide utility metering system (SCADA).
- Provide heating meters on the load side of all systems that use steam to water heat exchangers.
- The supply of any utility to a building shall not be activated until the specified metering is in place, functional, and has been commissioned.
- During the final phase of the project and before final close out, project contractor shall be required to prove that all utility meters are installed properly and function as designed and specified. The utility meter commissioning shall be accomplished by the contractor in conjunction with the project consulting engineers and The University of Arizona. Proper functionality includes:
 - Proper installation of the meter and associated appurtenances according to manufacturer's installation recommendations, University of Arizona specifications, and all applicable local codes and standards. Follow NEC and University of Arizona standards for electrical, sensor, and network cabling. [In general, U of A should require all cabling installed in mechanical/electrical/storage or unfinished space to be in conduit, and any cabling not in conduit to be in cable tray or properly supported to the structure – not supported on other conduit, piping, or infrastructure.]
 - Meter accuracy performing as-specified under all expected design flow conditions.
 - Local flow display installed as-specified, reading in the specified units.
 - Modbus interface communicating without error, providing 100% of requested data samples to client systems.
 - SCADA system receiving continuous data from the meter(s) in the specified units.
 - EMCS receiving continuous data from the meter(s) in the specified units.
 - Require calibration data, O & M manuals, details, etc., to be submitted prior to joint commissioning of the meter(s) with the Design Professional and the University.

End of Section 15980

DIVISION 15 - MECHANICAL

Section 15990 - Testing, Adjusting And Balancing

Introduction

Acceptance testing during construction and achieving an acceptable final air and water balance are critical elements of project completion. It is therefore extremely important that the balancing and the associated report be accomplished and submitted before or at the time of substantial completion. Similarly, timely reviews by the Consultant/UA will insure that the final balance is acceptable prior to occupancy.

Part 1 – General

- Ductwork Acceptance Testing
 - Test pressure for ductwork shall be at the design pressure class for the system.
 - Ductwork downstream of terminal units and ductwork with a design pressure less than 1 iwg may be approved via visual inspection by the University.
 - Testing to be per the latest edition of The SMACNA Air Leakage Testing Manual. If more stringent requirements are required discuss with PDC Mechanical Engineer and include requirements in the project construction documents.
 - Orifice tube to be provided of appropriate size to show allowable leakage within the calibrated range of the tube.
 - All tests to be witnessed by PDC Inspector.
 - Chart for converting pressure to volume shall be specific for the device used in testing.
 - If sample testing is allowed – the test sections will be randomly selected by the UA inspector from completed work.
- Piping Systems Acceptance Testing
 - Test all fire protection systems in accordance with all applicable NFPA Codes.
 - Piping to be inspected and pressure tested prior to insulation.
 - All pressurized piping systems tests to be for a 4 hour duration.
 - Gravity drainage systems test to be a 2 hour duration.
 - Pressure gauge for the test must have a suitable range such that the test pressure is in the middle 1/3 of the range.
 - All tests to be witnessed by PDC Inspector.
 - No loss of pressure allowed for all testing.
 - Gravity systems to be tested at 10ft hydraulic head or 5psig pneumatic if approved by the inspector.
 - Domestic water to be tested at 100psig.
 - Mechanical hydronic piping shall be tested to 150 psig.
 - Low pressure steam to be tested at 150 psig.
 - High Pressure stem to be tested at 200 psig.
 - Laboratory gas piping to be tested at 150psig.
- Vibration Testing
 - Vibration testing to be performed on all rotating equipment 3 horsepower and above in accordance with AABC Standards.
 - Equipment shall have a maximum vibration velocity reading no greater than 0.04in/sec.
- Fume Hood Testing: Discuss With UA Planning Design & Construction
 - Each fume hood shall be identified with a plaque indicating the location and number of exhaust fan serving the hood.
 - Each exhaust fan shall be identified with a weather-proof plaque indicating the location(s) of the fume

hood(s), by room number (s), that the fan serves.

- Air Systems
 - All work shall be in accordance with latest edition AABC, NEEB Standards and applicable sections of ASHRAE and SMACNA HVAC systems testing, adjusting and balancing procedures.
 - Air volumes measured shall be within $\pm 10\%$ of those shown on drawings unless otherwise specified for diffusers, grilles, registers where applicable and fans.
 - Ensure all temperature sensors and controls are calibrated prior to conducting test and balance procedures.
 - At the time of final inspection, recheck in the presence of the University and Design Professional, random selections of air quantities and fan data recorded in the certified report. Points or areas for recheck shall be selected by the University and Design Professional and be approximately 10% of the report data.
 - At the time of verification measure space temperature and humidity in a representative number of rooms to verify performance. Tabulate these results and bind into certified report as an appendix.
 - Testing to be conducted on a hierarchical principal, i.e. each piece of equipment for proper operation, followed by each sub-system followed by entire system, followed by inter-ties to other major systems.
 - Following final acceptance of the certified reports by the Design Professional, permanently mark the settings of all valves, dampers and other adjustable devices so that balance set position can be restored if disturbed at any time. Do not mark such devices until after final acceptance.
 - VFD controlled fan systems to be tested in bypass mode to verify satisfactory operation of static pressure high limit sensor.
- Piping Systems
 - Balance the entire water system to ensure all coils, heat exchangers, etc., are operating to design conditions. Adjust the circuits by means of the balancing valves and record balance position.
 - Each pump shall be checked for design, working and shut-off head conditions and any pump that varies by more than 10% from the design conditions shall have the impeller trimmed or changed until design conditions have been met.
 - Flow through all heat exchangers, chillers, boilers and other such equipment shall be balanced to ensure that the pressure drop through the equipment is within 10% of the manufacturer's design conditions.
 - If the design conditions cannot be met by adjusting the balancing valves throughout the system, then pump impellers shall be either changed or trimmed as required.
 - Initial balancing of coils shall be to ensure that the pressure drops are within 10% of the manufacturer's design conditions. When both the air and water systems are fully operational, entering air and water and leaving air and water readings shall be taken as close as possible to the peak design conditions to ensure the coil performance meets the design conditions. Coil water working conditions shall only be taken in conjunction with the air flow working conditions for the coil.
 - Coordinate with the Contractor to ensure that all necessary valves for control and balancing are installed in all locations required. Notify the University and Design Professional in writing that this coordination has taken place. Include in this letter any recommendations made regarding valves, locations, installation, etc.
 - Testing to be conducted on a hierarchical principal, i.e. each piece of equipment for proper operation, followed by each sub-system followed by entire system, followed by inter-ties to other major systems.
 - Following final acceptance of the certified reports by the University and Design Professional, permanently mark the setting of all valves and other adjustable devices so that balance set position can be restored if disturbed at any time. Do not mark such devices until after final acceptance.
- **Part 2 - Products**
- No Discussion.
- **Part 3 – Execution**

- All required balancing shall be completed and the final report submitted as a condition of substantial completion.

End of Section 15990

DIVISION 16 - ELECTRICAL

Section 16000 - General Discussion

Introduction Consultant shall incorporate the material in the DSS into the project specifications.

Refer any questions, clarifications regarding Division 16 to UA Planning Design & Construction.

The electrical system is very important to the operation of many of the aspects of the operations of the University of Arizona. Many of the buildings have testing which need to go on continuously and if the electrical power goes out during the testing then millions of dollars of work and equipment can be destroyed. For this purpose it is very important to supply the most reliable electrical equipment system that can be designed. It is for this reason that many of the systems and specifications enclosed herein exceed the requirements of the National Electrical Code. In addition it must be understood that:

The National Electrical Code is a minimum standard of the quality of work that can be used and shall not be used as a maximum for the quality of the electrical system.

The DSS is a standard each Consultant, Builder and Project Manager needs to study as a standard for ALL University of Arizona renovations and new work.

The local lighting ordinances are exceeded.

The University of Arizona is itself a small utility which maintains all of the secondary power distribution to all of the buildings on its' campus at both 13.8KV and 4.16KV. The standards specified herein reflect the requirements of this "utility". Note that at some other locations interface with standard utility requirements will be required. In those cases only will these standards be overruled. Attention to fault current and how it affects systems must be observed. The system energy capacity increases on an ongoing basis, as the result of ongoing campus utility modifications.

MINIMUM REQUIREMENTS

All electrical, mechanical, server and telephone rooms shall have smoke/heat detection. If, for any reason, electrical and mechanical rooms are equipped with liquid fire sprinklers, electrical equipment shall be NEMA 1 with sprinkler shields.

ELECTRICAL SWITCHBOARD ROOMS

Whenever the design for a new building or major expansion of an existing building is to take place special consideration shall be made for providing an electrical distribution switchboard room which is sized adequately to house all of the major electrical switchboard items which would need to be installed on the project. This shall include the primary distribution switchboard (usually 480 volt), the Fire alarm panel, some of the secondary transformers and 120/208 volt distribution panelboards, the automatic transfer switch, the generator status panel, and the motor control center (where required). This room shall have built in at least 40% spare capacity to allow for installation of future equipment as necessary and storage of pertinent electrical maintenance items. There shall be a minimum of two exits from the room with at least a 6' aisle between rows of electrical equipment or between electrical equipment and the wall. In addition a separate area shall be made to house the primary distribution transformer, the standby / emergency generator, and any primary distribution switchgear required (such as a PMH switch). This area shall be located in an equipment yard just outside of the main building walls.

SERVICES

Existing Services

Existing electrical services will require specific attention with respect to replacement and expansion. Projects where the existing service equipment is not to be replaced, need to be evaluated for fault current, overload, deterioration, grounding and safety violations. Where this work is designed by consultants, reports will be required at the Schematic Phase and addressed with UA Electrical Engineer.

New Services

All new services shall be designed by a Registered Professional Engineer.

Services, 1200 Amperes and Below

Services, 1200 amperes and below shall utilize stationary mounted power circuit breaker main breaker. Feeder breakers shall be electric, LSI, with communications capability.

Services Over 1200 Amperes

Services over 1200 amperes shall utilize draw out power circuit breakers.

All services shall

- Provide 13.8kv primary protection using a vacuum circuit breaker, 50/51 relay and snubber.
- Provide, 50/51 relays on the bus between the transformer and the main breaker
- Provide zone selective interlock between the 13.8kv- 50/51 relays, secondary relays and feeder breakers
- Provide arc flash calculations and PPE labeling for all electrical equipment, including panelboards.
- All main breakers shall be 100% rated.
- Shall be NEMA 3R Gasketed Construction outdoors.

SINGLE LINE DIAGRAM MINIMUM REQUIREMENTS

Single line diagrams shall be complete representations of the designed electrical systems. The goal is to allow the bidding and constructing contractor to bid the job using the correct equipment. The reviewer will require clear indications that all electrical parameters have been considered. Bidding and review shall not require tedious deciphering of keynotes. Nor shall the reader be burdened in flipping feverishly from sheet to sheet.

Single line representations shall include, but not be limited to, display of voltage levels, wye and delta configurations, bus sizing, sizes and types of main and feeder overcurrent devices, vertical bus sizes, horizontal bus sizes, pull sections, metering sections, grounding, spare bussing, bus extension provisions, transformer sizes, main breaker or lug locations for panelboards and switchboards, (bottom, top or feed through) fault levels, overcurrent device frame sizes and trip ratings, TVSS connections, TVSS overcurrent protection, feeder sizes, transformer sizes and housekeeping pads, primary cable conductor sizes and any other information necessary to provide a complete representation of the system.

The use of keynotes shall be minimized in the labeling of equipment and system components.

Switches, pull stations and automatic door closers in areas where the construction requires glass walls, glass doors and similar construction, shall require the architect to design mullions to accommodate orderly installation. Consultant shall coordinate these devices with the architect.

LIGHTNING PROTECTION

Lightning protection shall meet and exceed the requirements of NFPA 780 and the NEC.

Protection shall be provided where NFPA 780 calculation shows MODERATE conditions OR whenever directed by UA Facilities Design & Construction.

If available, UL MASTER LABELING shall be included.

Design shall be performed by the electrical registrant for the project, put on plan and sealed. It shall not be done as a requirement specification. The Consultant may feel free to seek the expertise of Lightning Protection Companies in preparing their (the Consultant's) design.

Attention shall be given to the Suppression Requirements of NEC for data, power and phone. Attention needs to be given to the material types and quality of lightning specific components and how they are fastened to the building. Mastics shall not be the primary method of attachment. Components shall be copper or bronze. Wire shall be copper. Down conductors shall be the braided UL approved copper product specifically designed for the application. Ground plates are allowed for existing buildings where grounding by other methods is not practical.

Examine the job site prior to completing your fee. Contact CCIT for suppression needs and methods. Determine such things as RF antenna on roofs, walls or parapets, "Add on" suppression for power shall be either APT OR CURRENT SYSTEMS products, not less than 180 ka per phase.

All firms shall provide graphic presentation of the system isometrically.

Consultants shall evaluate the need for lightning protection on all new buildings and building additions. Utilize the assessment criteria in NFPA 780. Risk factors in the highly moderate to severe category shall require lightning protection.

Cranes over 75 ft. high shall be bonded to ground with #115,000cirmil copper cable to the foundation UFER ground. Use the same cable for the UFER ground.

Consultants are urged to consider use of Early Streamer Emission Air Terminal Systems vs. the conventional Franklyn System.

COORDINATION OF PROTECTIVE DEVICES AND STUDIES

Coordination studies, protective relay studies and adjustments shall be performed by registered electrical engineers skilled in this area of expertise.

The consultant shall submit selectivity curves in the design document and final construction documents show clean coordination of the devices aforementioned.

The consultant shall write the specifications to reflect the following:

Contractor shall submit equipment based on the basis of design or one of the approved equals. The contractor shall provide with the submittal, a coordination study based on the equipment submitted. The contractor shall be required to submit equipment equal in characteristics to the basis of design. That is to say the selectivity of the overcurrent devices shall be as clean in coordination as the basis of design devices. The consultant shall clearly display this requirement on the DRAWINGS where the switchboards and service equipment is identified.

Should the contractor submit a study, including related equipment submittal, that does not give clean coordination, the contractor shall be obligated to change components to allow clean coordination and selectivity, prior to getting approval for releasing equipment for manufacture at no cost to the Owner.

The contractor may utilize factory trained coordination engineers to prepare the study. However curves must be plotted on standard log-log paper, 11 in x 17 in.

References to Clean Coordination and selectivity shall be as defined in IEEE STD 192, as interpreted by the University of Arizona Electrical Engineer.

Coordination shall reflect all intentions of system planning per IEEE Std. 192.

- Selectivity curves shall be labeled with plain English nomenclature that identifies the devices on the project single line diagram, not some dapper reference file name. Each curve set shall have a I-line on the same page.

Consultants shall provide fault current levels for all new equipment required to have ARC FAULT labeling as required in NFPA 70E. ARC Fault calculations and equipment labeling shall be identified to be a requirement for the electrical contractor to have performed.

TEMPORARY STANDBY POWER

Temporary standby power used to power existing critical (research not life safety) building loads shall require the presence of an approved generator technician for the duration of the outage.

New buildings equipped with standby engine generators shall be equipped with a "legally required" standby power

transfer switch and distribution panelboard. Connect all telephone, communications and server room systems to this distribution panelboard. Similarly, provide a transfer switch and distribution panelboard for optional standby loads (NEC Art 702). Connect Blue Light Phones to available standby power.

Elevator Rooms

Consultant shall coordinate the size of elevator equipment rooms such that they have 20% space clear wall space or 48", whichever is larger, upon completion of construction. All new construction drawings shall have riser diagrams, to scale, for each wall of the elevator machine room.

Part 1 – General

- These electrical standards represent the minimum quality of workmanship and the minimum quality of equipment which are required for the projects which are to be constructed on this site. The general attitude about the equipment and materials to be supplied is that this University will be here for many years to come and the projects which we construct now shall be able to be in service for 10, 15, 20, or more years without needing to be renovated due to the lack of quality of the electrical equipment or workmanship. In addition renovations will need to be made in the future to many of the areas which are under design today and for that reason spare capacity is to be built into the design to allow for a certain amount of flexibility for the future. Where the design engineer has some areas where he prefers to see an even higher level of quality than what is set by these standards he shall make the design to meet that level of quality as long as that design provides a cost effective design. Sometimes even though the design costs are considerably higher the actual costs including maintenance over the life of the product make it cost effective.
- Working In Confined Spaces
 - Whenever work is required within a confined space, e.g., utility vaults, utility tunnels, sumps, pits, sewers, etc., contact UA Risk Management and Safety Department for details and procedures on UA Confined Space Entry Program.
- As-Builts
 - As-Builts shall be prepared by the Contractor and professionally hand drafted in a clear legible manner. These As-Built annotations will then be drafted on the reproducible Record Drawing by the Consultant. See Tab B-9.
- Details
 - Consultant shall provide GRAPHIC SCALES AND PROJECT NUMBERS ON ALL SHEETS.
- Misc.
 - When panel boards are replaced, replace respective feeders and feeder breakers.
 - Designers shall coordinate motor service factors and efficiencies with mechanical trades and mechanical designers and bring this to the attention of the contractors.
 - The consultant shall make it clear to the contractor that deviations in design of major equipment shall not be a liberty that will be accepted. All equipment specified and supplied shall have been in the market place for a minimum of 2 years prior to bid date.

Part 2 - Products

- Specify the highest quality, best made type of equipment which is manufactured today. Balance this with maintaining quality while conserving cost. If there are materials which you know from working with them in the past which you know will not meet the requirements of this area of the specifications, then word your specifications to delete those items from being considered for use. Any types of material which by their very nature need to be looked at for meeting the quality that will be specified, needs to be specified to be submitted upon prior to installation for review by both the Design Engineer and the Facilities Engineer at the University of Arizona. Single sourcing of a certain type of material shall be made only when other materials would not meet either the standard of the University or the required operation of the system for which it is specified. In most

cases single sourcing will not be permitted. The use of one or two manufacturers which supply equipment which is known to meet the standards which are required for the particular operation which is specified shall be utilized. Other manufacturers which may not be known at the time of design or who in the past have manufactured equipment which is not the same quality as that which is specified then will have the ability to submit their equipment in accordance with the requirements of specification section 1300.

- When specifying equipment, attention shall be given to assure that if a particular manufacturer is specified, that all related equipment is specified with regards to the same manufacturer. For instance, if GE were specified for panelboards, regards should be given that disconnects, switchboards, motor starters and transformers be GE. Single sourcing already has been officially justified for fire alarm equipment, intrusion detection equipment, telephone/data hardware, primary cable, primary pad mounted switches and variable frequency drives. Prior approval is required for engine generators, transfer switches and primary cable deviations. There is no or equal to be considered after bidding where prior approval is required.

Part 3 - Execution

- It is the intent of the University to have all new work installed in a quality manner and in a way that it is accessible for future maintenance and expansion. The installation shall comply with both the requirements of OSHA, ADA Guidelines, NFPA, NESC and the NEC. In complying with OSHA regulations we wish to comply especially with the requirements of the lockout/ tagout regulations, and provide the personnel who have to work on the mechanical equipment serviced by the new electrical system with a completely maintainable system based on those regulations. As far as the quality of workmanship, we would like to have the electrical system installed in such a way that it both is functional, and looks like it has been installed in a professional manner.
- Contractors shall be required to label all equipment with ARC FAULT labels as outlined and required in NFPA 70E.

End of Section 16000

DIVISION 16 - ELECTRICAL

Section 16050 - Basic Electrical Materials and Methods

Introduction

The design shall be set up such that all equipment shall be provided and installed with the highest degree of quality and workmanship in both the type of equipment installed and the quality of the equipment installed.

Part 1 - General

- All work associated with the installation of electrical equipment at this site shall be accomplished by skilled workmen which are experienced in the type of work for which they are to accomplish. The contractor shall be licensed to do commercial or industrial electrical work. Each work crew shall consist of a maximum of 1 helper for each journeyman electrician. For all work involving the installation of medium voltage (above 600v) equipment the work shall be accomplished by a contractor having a class A-17 license. The workers on medium voltage systems shall be journeyman electricians. The definition for a journeyman electrician will be that the electrician shall have completed a minimum of 5 years in a combination of training and education of electrical equipment installation under the direction of skilled journeymen electricians.
- The plans and drawings are complimentary and anything indicated by either shall be required to be installed as if it were indicated on both.
- All work shall be installed and coordinated with all other trades. Conflicts shall be solved through a joint decision by the trades and shall be presented to the University for their approval.
- It is the responsibility of the contractor to visit the site prior to bid, and familiarize himself with any and all site conditions.
- Laboratory panels shall be accessible to users, not locked in electrical/mechanical rooms.
- Use of the metal clad cable, special restrictions:
 - Metal Clad (MC) cable will be permitted under the following circumstances:
 - In walls, for electrical outlets, stud wall construction, dry locations.
 - Following strict procedures regarding the routing. Each wall may have the MC cable running horizontally to adjacent receptacles. The run of MC cable shall not run horizontally to adjacent walls. Instead, the run shall go up in the wall to a J-box in the interstitial ceiling space.
 - Horizontal runs of circuitry in the interstitial ceiling space shall be in EMT or GRC. Home runs shall be EMT or GRC.
 - Metal Clad (MC) cable shall meet the following:
 - It shall be steel with factory installed conductor, stranded copper wire, each conductor color coded.
 - The end fittings shall be Arlington Industries, SNAP 2 IT with insulated throats. Substitutions will not be considered.
- All other wiring systems shall be as specified.
- Elevators shall have their own direct feed feeders, from the main service switchboard, panel or mains.

Part 2 - Products

- All products specified for use at this site shall be UL listed or CSA certified for the use specified herein.
- Provide submittals for all equipment as indicated in the section under which it is specified in accordance with the provisions of Division 01300.
- All equipment shall be protected from the elements between time of delivery to site and actual installation. No equipment shall be installed until it is obvious that no normal damage will occur to the equipment between the time of installation and the end of the contract. All equipment, whether installed or on site awaiting installation, remains the property of the contractor until the end of the contract.
- **Conduit Sleeves / Concrete Walls & Floors Above Grade**
 - Shall be schedule 40 steel
 - Sized for full dimensions of insulation and fire caulked where required
 - Install in all exterior walls, fire walls and floors
 - Floor sleeves to extend 1" above floor surface
- Conduit sleeves in non-rated, non-masonry walls or partitions. Provide 24 gage galvanized steel.
- **Part 3 - Execution**
- All work shall be accomplished in accordance with the latest NEC. A copy of the latest code book and project specifications shall be kept at the premises.
- Prior notice of any power shutdowns or any disruptions to existing facilities shall be coordinated by the contractor as directed by the Construction Project Manager.
- All work shall be inspected prior to covering and any work covered prior to inspection will be made available for inspection at the option of the Construction Project Manager. No additional fees will be provided to uncover work covered prior to inspection.

End of Section 16050

DIVISION 16 - ELECTRICAL

Section 16110 - Raceways

Introduction

The general attitude on conduit systems is that in the future any area which does not have surface mounted raceways in the area at present shall not have them in the future. New conduit in an existing gypsum board wall shall be either fished with steelflex or EMT caps, or shall have wall notched and then patched for installation of new conduits. In addition it is the intent of this section that conduits being installed now shall provide for additions in the future.

Reducing washers are prohibited except where approved by the UA Electrical Engineer.

The minimum size of each conduit shall be 3/4" unless noted otherwise below.

The maximum number of circuits in a new conduit is 3. Remodels may add up to 6.

For homeruns a j-box shall be located above the lights in an accessible location to allow for future expansion. No home run shall terminate in a wall mounted device box. Use a separate J-Box.

For underground utility projects the information in section 16115 shall apply.

Do not substitute conduit fittings for pull boxes.

- 1/2" conduit shall be allowed where terminating to a one gang device box from an above ceiling J-box.
- Specific housing projects will permit 1/2" emt raceways in lieu of 3/4" but homeruns shall be 3/4".

Part 1 - General

- Provide a submittal for conduit, wireways, and fittings.
- Reducing washers are prohibited except where specifically approved by the electrical inspector. A ground bushing will be required wherever reducing bushings are authorized.
- Stud to stud supports are required in all metal framing, in order to support boxes.
- Scrap conduit shall not be used for conduit supports.

Part 2 - Products

- EMT
 - Use steel compression type fittings, and couplings.
 - Connectors shall have insulated throat.
 - No factory emt bends allowed below 1".
 - No Condulet type fittings over 1 1/2" unless approved by UA Electrical Engineer.
- Galvanized rigid steel (GRC)
 - No running threads.
 - Use one piece couplings.
 - Use Ericsons only where approved by engineer.
 - Double locknuts and threaded insulated steel bushings at all boxes.
 - Minimum 3/4".
 - No Condulet type fittings over 1 1/2" unless approved by UA Electrical Engineer.

- Steelflex
 - Minimum size $\frac{3}{8}$ " with #14 THHN wire. (For connection to an individual light fixture or with a single circuit)
 - No pre-wired raceways.
 - 1 screw compression or set screw connectors only.
 - Maximum 6' length.
 - No Aluminum flex.
 - No BX cable.
 - No MC except as noted in 16050-1 or as approved by UA Electrical Engineer.
 - Use integral insulated throat fittings.

- Liquid tight flexible conduit, steel core (LTFC)
 - Equal to Sealtight.
 - Minimum size $\frac{1}{2}$ ". (For connection to a single motor or device with less than 5#12)
 - Use insulated throat compression type steel connectors.
 - Maximum length 6'
 - All device wiring shall be field wired by the electrical contractor. Suitcase type connectors shall not be used. Submit samples for evaluation by UA Electrical Engineer.

- PVC
 - Schedule 40 minimum wall thickness.
 - Minimum size $\frac{3}{4}$ ".

- SURFACE MOUNTED RACEWAYS
 - Shall be as manufactured by Walkerdut or Wiremold.
 - Minimum size shall be equal to type 700 WM.
 - No PVC or plastic wiremold products will be permitted.
 - Utilize manufacturer's products for all transitions from conduit systems and for all bends, offsets, or otherwise appropriate situations. Minimize field modifications to the raceway.

- Conduit bodies allowed $\frac{3}{4}$ " through 1 $\frac{1}{4}$ " only with approval of the UA Electrical Engineer.

Part 3 - Execution

- Conduit system must be complete prior to pulling cables.

- EMT
 - Use in gyp board walls, surface mounted in equipment rooms, and where not subject to moisture or damage. EMT to route vertically only in walls in areas with drop ceilings. No horizontal runs through walls unless specially approved by UA Electrical Engineer.
 - Condulets shall not be used indoors in place of pull boxes.
 - Route conduit not less than 1' above drop ceilings and no higher than 36" above unless approved by PDC.

- Galvanized Rigid Steel
 - Use above grade where subject to weather.
 - Use where subject to moisture.
 - Use where subject to damage.
 - Use for all bends and offsets in underground runs or in block walls.
 - Use within 5' of building walls, if penetrating the structure, in underground runs.

- Use in all light pole bases.
- All indoor runs larger than 4" except communications or special systems.
- Underground or in concrete must be half lap wrapped with 10 mil PVC tape or painted with bitumastic compound.
- Use in tunnel
- Use at a height of 4' and below in all Electrical, Equipment and Mechanical Rooms or where subject to physical damage.

- Schedule 40 PVC
 - Use only below grade.
 - Use only with approved PVC supports.
 - Use inside of block walls, with solid grouted cells.
 - May be used as a sleeve inside of building for grounding or lightning protection wiring.
 - All bends and offsets shall be in rigid steel (GRC) elbows.
 - All stub ups shall be GRC.
 - See Section 16115 for installation requirements (dept, encasement, etc.).

- Steelflex
 - Use only where permitted by UA Electrical Engineer or for feed to lights or smoke detectors in a t-bar ceiling.
 - Use where required for fishing existing stud walls to a single device.
 - Provide sufficient length for loop at bottom of flex. (Do not draw tight).
 - Use for dropping conduit down an existing wall with limited ceiling height.

- Liquid Tight Flexible Conduit (LTFC)
 - Use only where permitted by UA Electrical Engineer.
 - Use for final connection to all equipment.
 - It shall not be used to penetrate sheet metal enclosures.
 - Provide sufficient length for loop at bottom of flex. (Do not draw tight).

- Surface mounted raceways (Wiremold or approved equal)
 - Use in renovation projects where existing walls do not allow fishing or notching of walls. All other uses shall not be permitted without the approval of the UA Electrical Engineer.
 - Must use Wall box connection when connecting to a flush mounted wall box.
 - Must use center dividers when used for more than one system.
 - File all cuts smooth prior to installation.
 - Use factory manufactured cutters.

Support all conduits from structure minimum of 5' centers and within 18" of a box; connector, coupling or factory 90° bend and at closer intervals where required by NEC.

Reference Section 16190 for means of support.

End of Section 16110

DIVISION 16 - ELECTRICAL

Section 16115 - Underground Conduits And Distribution Duct Banks

Introduction

When preparing the layouts for new underground distribution for the electrical systems, future capacity shall be included to provide for expansion/modification of the services in an area. In this area common sense and a discussion with the UA Electrical Engineer and the FM Electrical shop shall be used in determining how many additional conduits shall be installed in a duct run above the number needed for actual work in the project. In addition it shall be the responsibility of the engineer doing the design to consult any and all of the as-built documentation of an area prior to laying out the duct bank for a particular area. Any changes caused by the lack of proper investigation shall be fully documented by the engineer in the form of revised drawings and not notes added to the original drawings. Fully document and detail the drawings such that major obstructions and other utility services are clearly indicated on the drawings.

Part 1 - General

- Provide submittals for conduit, fittings, manholes, handholes, and all associated appurtenances.

Part 2 - Products

- UNDERGROUND CONDUIT AND DUCT BANKS
 - Use GRS (galvanized rigid steel) or PVC schedule 40 for underground conduit and duct bank installations. Installation parameters are prescribed in Table 1 below.
 - Where required concrete encasement shall be either 2000 psi or 3000 psi.
 - Red colored concrete encasement, where required, shall use a red pigment integrally mixed into the concrete. Dry shake or broadcast coloring agents are not to be used.
 - Use GRS (galvanized rigid steel) for all offsets and bends. Tape all underground GRS conduit with 10 mil PVC tape, half lapped or coat with a bitumastic compound.
 - For concrete encased conduits use manufactured PVC spacers and mounts for support and spacing of the conduits. Do not use concrete blocks or other means to support and space conduits that are to receive concrete encasement.
 - A metallic backed marking tape shall be installed 12" above all underground conduits and duct banks.
 - A #10 AWG trace wire shall be installed in all utility trenches.
- MANHOLES AND HANDHOLES
 - Minimum 12" x 18" x 12" with solid nominal I.D. concrete bottom for power or lighting runs. For High Voltage work manhole shall be sized similarly to existing manholes on campus.
 - Shall be constructed out of 3000 PSI steel reinforced concrete.
 - Shall be traffic rated construction.
 - Cover shall indicate type of wiring enclosed within.
 - Shall include a securely mounted removable ladder when over 4' deep.

Part 3 - Execution

- UNDERGROUND CONDUITS AND DUCT BANKS
 - Install underground conduits and duct banks per Table 1, below, and locate a minimum of 1' from other utility systems, including phone, steam, sewer, chilled water, etc.

Table 1

Underground Conduit and Duct Bank Installation Requirements			
	Above 600V	600 V and Below	Other Systems
Below Building Slabs	PVC or GRS, 36" deep, red concrete slurry	PVC or GRS, 18" deep, no concrete encasement required	PVC or GRS, 18" deep, no concrete encasement required
Outside of Bldg.	PVC or GRS, 36" deep, red concrete encasement, 3000 psi at drive lanes. 1000 psi Slurry all other locations	GRS, 36" deep, no encasement, or PVC, 24" deep with 2000 psi concrete encasement, plain	GRS, 36" deep, no encasement, or PVC, 24" deep with 2000 psi concrete encasement, plain
Outside of Bldg. Min. depth requirement cannot be met	Special permission required, Contact PDC Inspection		

- Install not less than 3 - #4 reinforcing bars tied to a "U" shaped stirrups at 8' centers for duct banks under roadways.
- Concrete encased with a minimum envelope of 3" around each conduit where encasement is required.
- Minimum 3" spacing between outer diameter of conduits.
- Conduits to be used for high voltage cable shall be installed by journeyman electricians having minimum of five years experience in the installation, splicing, and testing of high voltage wiring. Contractor shall have class A-17 license for minimum of 2 years prior to work. Refer to 16050-1 part 1
- Use bell adapters where conduits enter manholes.
- Concrete shall be red dyed utilizing red dye mixed into the concrete for a minimum of 5 minutes prior to pouring. Minimum of 1 bag of dye per 1 yd of concrete.
- For 4" diameter and larger GRS conduit bends, minimum bending radius shall be 48". Standard factory bends may be used for 3-1/2" diameter and smaller GRS conduit bends.
- Tie banks down and stake using rebar at each support.
- Spacers and supports to be at 5' centers.
- Conduits shall be cleaned and tested for continuity prior to installation of cables as follows:
 - A steel sectional mandrel shall be pulled through the conduit. The mandrel outer diameter shall not be less than .5" less than the inside diameter of the conduit.
 - Should the mandrel become stuck in the conduit then the length of conduit where the mandrel was stuck shall be condemned and replaced to the satisfaction of the UA Electrical Engineer.
 - The conduit shall then be swabbed out by pulling through a brush and/or rags which remove any additional debris from the conduit.
 - Spare conduits shall receive a pull string and be capped at both ends. Spare conduit shall be identified as to other end. Spare conduit where subject to weather shall be sealed using a coupling and steel insert.
- **MANHOLES AND HANDHOLES**
 - Ring and lid shall be installed above grade so that water drains away from them.
 - Shall be installed on a bed of gravel (minimum of 12" deep) with a drain hole to allow for water to drain out of them.
 - Shall be installed with cover flush on sidewalks.
 - Shall be installed with top of cover minimum 2" above grade in landscaped areas.

- For handholes use cover appropriate to the area located.
- For manholes use traffic rated cast steel outer cover with an inner lid which can be padlocked from above. The inner lid shall be welded to the manhole ring.
- Provide a $\frac{3}{4}$ " x 10' ground rod driven into the bottom of the manhole near one of the sides for grounding of wires and cables.
- Provide pulling irons opposite potential duct entrances.
- Have inset unistrut to allow for cable racks in manholes.
- HV Cable racks shall have porcelain insulators. Loop high voltage feeders around the inside of the manhole tied to the insulators.
- Manhole covers shall be manufactured with inscriptions for "Electrical" and "Communications" and be weld-bead inscribed with U of A. This welding shall be performed by a certified MIG (GMAW) welder with the proper approved skills.
- Manhole steel rings, frames and covers shall be "NIKKO". No exceptions.

End of Section 16115

DIVISION 16 - ELECTRICAL

Section 16120 - Wire and Cable

Introduction

All wire to be in conduit UNLESS APPROVED BY UA Electrical Engineer.

Design is to make conduit system available for use in future.

Maximum of three circuits in each conduit for all new installations. Remodels may have six.

Where more than one 20 amp circuit is installed in a conduit with a common neutral, size neutral conductor to #10.

MC Cable may be used for branch circuits after the home run.

Part 1 – General

- Wiring of different system voltages shall be in separate raceways separated gutter compartments required.
- Wiring color coding to be as indicated under Section 16195.
- Grounding and grounded conductors to be identified at all visible points.
- In order to provide for future wiring when calculating box fill maximum fill shall be 70% of code fill requirements.
- All power and lighting conduits shall contain a ground conductor sized per NEC 250.
- All wire shall be new.
- All wire removed from conduit shall be discarded.

Part 2 - Products

- 600 volt insulation minimum on all cables unless specified otherwise.
- All wiring to be minimum #12 AWG stranded copper conductors. Only exception is for fire alarm circuits where #14 solid copper conductors shall be used.
- All wire is to be new and brought to the job site in unopened packages.
- Use THHN/THWN for all sizes between #12 and #4 AWG indoor, dry locations. Use XHHW-2 for all sizes #2 and larger or all outdoor or wet locations. Do not use #3, 300 kcmil or 400 kcmil.
- Control cabling for instrumentation shall be twisted shielded pair No. 18 ga. Minimum copper conductors with overall foil shield where used for 4 to 20ma or 1 to 10 volt control signals. For 120 volt control signals use minimum of No. 14 ga. Stranded copper.
- For wire sizes #6 and smaller as appropriate for the devices, wiring may be connected using wire nut type of wiring connectors. Twist wires together before applying wire nut. Interior of nuts shall be metallic. Submit samples for approval.

- Joints in cables #6 and larger shall be made with solderless connectors. Either compression type connectors or box lug connectors and a combination of rubber and plastic "Scotch 33" type of tape shall be used. Split bolt connectors are prohibited.
- Connections at terminal strips shall be made using either compression type of terminals or a ring or spade connector must be installed on the wire before connecting to a screw terminal. Wrapping stranded wire at a screw terminal is not permitted.
- Suitcase type connectors are disapproved.

Part 3 - Execution

- Wire shall be color coded throughout its length. Wires #8 and smaller shall be color coded using colored insulation. Wires #6 and larger shall be identified with multiple rings or spirals of color coding tape at each box or piece of equipment.
- Use fire alarm manufacturers standard color coding for fire alarm circuits.
- Conduit system shall be complete prior to pulling in wires.
- Use only UL approved wire lubricant. No grease or silicon which could damage the insulation of the cable shall be used.
- Any run of conduit which does not permit conductors to be pulled in readily shall be condemned and replaced to the satisfaction of the UA Electrical Engineer.
- When pulling in cables for feeders use power operated pulling equipment only where specifically approved by UA Electrical Engineer.
- Protect wires at all locations where exiting from conduits.
- Carefully cable all wires in panelboards, gutters, and wireways. Use tie wraps where needed.
- Do not use tape to cable wires either for pulling into conduits, or for cabling in panels, gutters, or wireways.
- Do not combine systems of various voltages or circuits from separate sources in the same conduit system.
 - Exceptions
 - Readily identifiable low voltage conductors for lighting system control may be run in the same conduit as the power conductors for a terminal drop to a light switch or to a single light fixture.
 - Motor control wires (not including control wiring for a VFD) may be installed in the same conduit as the power wiring if they can be installed without damaging the smaller wiring.

End of Section 16120

DIVISION 16 - ELECTRICAL

Section 16122- PRIMARY POWER CABLES

Introduction (Refer to Appendix For Approved Master Spec.)

The goal at this site is to provide looped power distribution to all buildings on the main campus power system. In addition in the future we would also like to change the service to the University to eliminate all of the 4160 volt distribution and replace with 13.8 KV distribution. All new designs should reflect that plan. All cables should be capable of connecting to either 13.8 KV or 4160 volt systems. The cable should be either tied to an existing looped system with PMH switches or to a new looped distribution system as per the U of A Electrical Engineer. All cable should be shielded and run in duct banks out of the existing (or new) tunnel system.

Part 1 - General

- Incorporate attached specification as applicable into your specification.

Part 2 - Products

- Incorporate attached specification as applicable into your specification.

Part 3 - Execution

- Incorporate attached specification as applicable into your specification.

End of Section 16122

DIVISION 16 - ELECTRICAL

Section 16130 - Boxes

Introduction

Types of boxes - outlet and receptacle boxes, and metal junction and pull boxes. Underground concrete boxes or manholes are discussed in underground distribution systems.

Boxes are to be left in such a manner that they are both accessible for future access, and that spare space (per NEC) is available for working with additional conductors.

Part 1 - General

- **DEVICE BOXES**
 - **NEW WORK** minimum size to be 4"sq. x 2 1/8" deep with adequate space for devices, wires, and 30% spare fill capacity except as approved by the University.
 - **REMODEL** use flush mounted boxes in existing walls (notch GWB walls if necessary). Use 4" sq. boxes.
- **JUNCTION BOXES**
 - **NEW WORK** minimum size 4 11/16" sq x 2 1/8" with 1/2" and 3/4" knockouts on each side. For conduits 1" and larger use boxes 6 x CS (conduit size) X 8 x CS, x 4" minimum or as per NEC 314. Provide for 30% spare fill capacity in all junction boxes. Extension boxes are not permitted.
 - All home runs shall have a j-box located in an accessible location above the ceilings (in interstitial ceiling spaces).
 - All existing junction boxes in an area remodeled shall be left accessible or relocated to an accessible location.
 - All j-boxes 4 11/16" sq. x 2 1/8" sq. or smaller shall have both 3/4" and 1/2" knockouts on all sides.
 - Ground tails shall be installed in boxes prior to rough-in.

Part 2 - Products

- **DEVICE BOXES**
 - Shall be galvanized steel one piece boxes. No more than one plaster ring shall be utilized with each box. Gangable boxes or handy boxes shall not be used without prior approval of the UA Electrical Engineer.
- **JUNCTION BOXES**
 - Shall be galvanized steel or metal with baked enamel. Where used outdoor boxes shall be NEMA 3R rated. Where subject to corrosion shall be NEMA 4X SS.
 - For new work no extension boxes will be permitted.

Part 3 - Execution

- **DEVICE BOXES**
 - No Madison clips used as supports.
 - Rigidly supported to structure independent of conduit system support.
 - Flush mounted shall not have more than 1/8" gap.
 - No back to back devices or boxes in walls unless approved. Offset all boxes in non-fire rated walls minimum of 6". For fire rated walls provide minimum 24" separation or use approved fire assembly.
 - Where transitioning from flush mounted j-box to surface mounted raceway, horizontally mount the plaster ring so that the proper type of wall box connection may be utilized with the surface mounted raceway.

- Surface mounted boxes shall be 4" square boxes, with industrial raised device plates. These shall be only used in equipment rooms or where specifically approved by the UA Electrical Engineer.
- Cut in boxes may be used in remodel applications where conduit is fished down existing stud walls.

- JUNCTION BOXES
 - Shall be rigidly supported to structure independent of conduit system.
 - Shall be accessible.
 - Runs between junction boxes shall not exceed 90'.
 - Shall be identified per Section 16195.
 - Shall not be located more than 3' or less than 1' above a drop ceiling.
 - Covers shall be attached with machine screws only. NO self tapping screws or wood screws shall be utilized in attaching the cover.
 - Reference 16190 for supports and anchors.
 - Shall not have concentric knockouts unless specifically approved by the UA Electrical Engineer.
 - Use grounding bushings on all enclosures having concentric and eccentric knockouts where such knockouts are approved by the UA Electrical Engineer.
 - No powder actuated, plastic or lead fasteners. Install boxes with machine screw type fasteners.

End of Section 16130

DIVISION 16 - ELECTRICAL

Section 16140 - Devices

Introduction

The design should take into account not only what type of equipment is to be connected to the device but also what type of loading will occur on the circuit when determining the number of receptacles on each circuit.

- Designers shall provide at least one outlet on each wall unless construction with doors and walls prevent sensible construction.
- Minimum of 1 convenience circuit shall be installed in each individual office.
- Maximum of 6 receptacles on each circuit for office areas.
- Dedicated circuit for copiers.
- Dedicated circuit for laser printers.
- Dedicated circuit for microwave.
- Hallway receptacles shall be connected to circuits which are independent of the office or other room receptacles.
- Wall switches shall be on the latch side of doors according to the architectural plans. Where two level switching is used switches shall be in the same J-box. Motion sensors with override button shall only be installed in specific situations approved by UA Electrical Engineer.

Part 1 - General

- Due to the rough treatment of devices at this facility industrial quality heavy duty specification grade devices and receptacles are used.

Part 2 - Products

- Pass & Seymour, Arrowhart, Leviton, and Hubbell are approved manufacturers. Hubbell shall be the basis of design.
 - All devices shall be heavy duty specification grade, plug back wired minimum 20 A rated devices. Included here are standard wall outlets, light switches, GFCI, and IG receptacles.
 - Receptacles shall have a one piece brass strap and grounding system.
 - Color of devices shall match the existing for main campus modifications, and ivory for AHSC and all new construction.
 - Devices used for emergency power shall be red.
 - Isolated ground devices shall be orange.
 - All wall plates shall be stainless steel, satin finish, minimum of .035" thick. Sierra Brand, to match plates specified in 16700.
 - Exterior device plates shall have separate covers for each section of the device. Plate shall be constructed of either polycarbonate or cast aluminum. The unit shall be rain tight with plug in use.
 - Lighted toggle switches shall be used in all electrical, mechanical, equipment rooms and in tunnels. Color shall be white or clear. Wire so that they glow when the power is off.

Part 3 - Execution

- Install receptacles with the ground stab up in vertical mounting or neutral stab up in horizontal mounting.

- Install such that devices are either perpendicular or parallel to the floor or adjacent walls.
- All devices shall be pigtail connected and not used as a terminal strip or feed through connector for devices down line.
- Receptacles shall be mounted at 18" above finished floor to center.
- Lab receptacles shall mount minimum of 6" above counter top. (Except where using countertop mounted devices, manufactured for that purpose.) Max height shall not exceed 42".
- Light switches shall mount at +42 above finished floor to center.
- All receptacles shall be identified per Section 16195.
- Install wiring under back wiring clamp without use of Stak-ons or crimp terminals except at ground terminals.
- Receptacles not installed in back splashes can be installed vertical above counters.
- Provide samples for approval.

End of Section 16140

DIVISION 16 - ELECTRICAL

Section 16160 - Cabinets and Enclosures

Introduction

Since this is typically a special item used only on specific items this section shall be as specified for the particular project and shall be worked out between the Design Engineer and the PDC Electrical Engineer.

Part 1 - General

No discussion.

Part 2 - Products

No discussion.

Part 3 - Execution

No discussion.

End of Section 16160

DIVISION 16 - ELECTRICAL

Section 16170 -Motor Starters

Introduction

All motors shall be protected by motor starters (except for fire pump systems or where motor has internal motor protection).

Where available use 480 volt 3 phase power for all motors rated above 1/2 hp. These motors should be protected by three phase motor starters with overloads on all three phases. Where 480 volts is not available utilize 3 phase power at 208 volts.

All motors 1/2 hp and smaller shall be 120 volt.

All motors 1 hp and larger shall utilize magnetic type of motor starters. All motors controlled through the use of control systems shall utilize magnetic type motor starters.

Where five or more starters are required in the same area utilize a motor control center arrangement.

Where both a starter and a disconnecting means are required at the same location use a combination starter. When using automatic controls associated with the motor use a magnetic type starter. When no automatic type of control is needed use a manual motor starter.

Motor starters shall be supplied and installed by the electrical contractor. It shall be required for the Electrical design engineer to coordinate all of the sizes of the motors and indicate the sizes of the motors on the drawings. Where motor sizes shall change due to design changes by the mechanical contractor he shall coordinate the same with the electrical contractor at no additional cost to the University of Arizona.

Part 1 - General

- Acceptable manufacturers shall be Allen Bradley, General Electric, Cutler Hammer, Square D or prior approved equal.

Part 2 - Products

- All motor starters shall be NEMA size starters. No IEC type starters shall be utilized.
- Manual motor starters shall be heavy duty, rated minimum of NEMA size 0, and shall have separate replaceable thermal type overload relays.
- Magnetic motor starters shall be heavy duty, rated minimum of NEMA size 0, and shall have separate replaceable thermal type overload relays, one per phase.
- Combination type motor starters shall utilize type FRN rejection Full size fuses rated minimum of 600 volts. With magnetic motor starter as per above, separate 120 volt control transformer, hand- off-auto switch, red and green pilot lights, and minimum of two sets of auxiliary contacts. If an external control source is used then an auxiliary disconnect device is to be added to the starter to disconnect this when disconnecting power for the starter.
- Enclosures shall be NEMA 1 for indoors, NEMA 3R gasketed or the equivalent for outdoor, and NEMA 4X SS where subject to corrosion. The basis for outdoor design/construction is Cutler Hammer NEMA 3R/12.

Part 3 - Execution

- Motor starters shall be installed at an accessible location. All motor starters shall be identified in accordance with Section 16195.

- Clearances as specified in NEC 110.26 shall be provided.
- Maximum height shall be +72" aff.

End of Section 16170

DIVISION 16 - ELECTRICAL

Section 16175 – Elevator Power and Controls

Introduction

There are unique University requirements. Refer to sample specification in the Appendix Section.

Part 1 - General

- Consultants shall provide details on plans, clearly reflecting the requirements within. The consultant shall not specify pre-manufactured equipment for machine room shunt trip and control requirements. Specifically note on the plans that the pre-manufactured items are not acceptable.
- **POWER**
 - The consultant shall specify generous circuitry that accommodates circuit sizing requirements by vendors notorious for requiring over sizing. Provide notations that require the contractor to provide system upgrades when elevator equipment requires larger capacity system components in excess of that shown on the construction documents. The consultant shall explicitly state in the specifications that these upgrades shall be performed without additional cost to the University. The consultant is directed to intentionally size feeders for worse case conditions.
 - Provide a minimum elevator machine room size of 100 square feet, exclusive of the area above the hoistway (for traction elevators), and without any odd corners, narrow passages or structural interferences.
 - Main electrical elevator feed shall employ a molded case shunt trip breaker and a suitably sized enclosure. Larger enclosures for electronic type breakers are to be avoided as they take up too much room in an already cramped service space. Requirements for electrical coordination to be accomplished upstream of the main elevator feed. Engineers will feed the elevator breaker from the building's main switchboard, so as to maintain a 4 to 1 separation in current trip settings between the elevator breaker and the switchboard main breaker. This is to be done regardless of the convenience of any closer distribution points that cannot afford the 4 to 1 separation.
 - Ancillary electrical elevator equipment shall be fed from a separate, solely dedicated, elevator electrical DEADFRONT LOAD CENTER 120/208V, 3 phase, 4 wire. This elevator load center shall only be used for elevator related equipment and devices. It will provide the required means to lockout the equipment for service. Required characteristics of elevator electrical Load center are: surface mounted, copper bus, no door, dead front, 14 inches wide, lockable (lockout) breakers and a maximum size of 12 full size breaker spaces. Additional spaces are authorized only where the number of elevator related loads increases above 12 spaces. Unused breaker spaces shall not have any spare breakers installed. Ancillary elevator equipment to be fed from this panel may be, but is not limited to, the following:
 - Shunt trip control feed
 - Machine room lights/receptacles
 - Elevator car lights
 - Elevator pit lights/GFI receptacle
 - Elevator pit sump pump
 - Machine room A/C
 - Elevator Fan (A/C)
 - Hydraulic oil cooler
- Power for the machine room load center shall be on the life safety engine generator, when available.

Part 2 – Products

- **SHUNT TRIP AND RELATED CONTROLS**

- The machine shunt trip breaker shall be enclosed in a HOFFMAN ENCLOSURE having a dust tight hinged door with external disconnecting handle for the breaker. The breaker shall be electronic type with LSI features, including short time adjustment. It shall have one N.O. and one N.C. contact for future use.
- The enclosure shall be oversized to accommodate the neat field wiring and installation of controls and relays associated with the requirements of all applicable codes.
- Terminal/barrier strips shall be 20 ampere rated, bakelite, industrial grade.
- Provide load center as described in Part 1, above.
- Provide 120 Volt control system with switch, Neon Pilot and Current Limiting (CL) fuse.
- Provide a schematic diagram and parts list for mounting within the enclosure.

Part 3 - Execution

End of Section 16175

DIVISION 16 - ELECTRICAL

Section 16190 - Supports

Introduction

This section covers support requirements for conduits, light fixtures, and all other electrical equipment.

Supports as specified herein are more strict than those required by the NEC due to the increased accessibility to areas by U of A maintenance personnel.

Part 1 - General

- All materials shall be corrosion resistant (supports, fasteners, misc. hardware).
- Minimum support requirements shall be as specified in the NEC for electrical equipment. Where specified herein as more stringent the more stringent shall apply.

Part 2 - Products

- CONDUIT SUPPORTS shall be as follows:
 - Width of structural strut trapeze shall not exceed 12".
 - Where individual conduits are run on walls and where appropriate one hole straps may be used. Where more than two conduits are run in parallel or where conduits are 1 1/2" or larger, support using approved structural strut members fastened to the structure at minimum of two points. Minimum strut length is 12 inches.
 - Single conduits trapeze above ceiling use 1/4" all thread and conduit hangers up to 1 1/2". For 2" and above use strut rack and minimum of 2 - 3/8" or larger all thread rods.
 - Wire shall not be used as a method to fasten conduits above ceilings. Conduit hangers or straps as appropriate shall be used to rigidly support the conduits in each situation. 18 gauge or larger galvanized tie wire may be used to tie conduits inside of metal stud walls.
 - Conduits above drop ceilings shall be supported independent of wire supports for drop ceilings, and shall not be supported on wires. Caddy #812MB18 box and conduit supports or equal may be used.
 - Fixture whips, however, shall be permitted to be supported by the fixtures seismic wire utilizing approved clips
 - All fasteners shall be steel threaded inserts or steel expansion shield anchors for location used. One hole straps shall be either connected to the wall studs using appropriate screws or to the wall using expansion bolts. In hollow masonry walls steel toggle bolts may be used. Plastic or lead expansion anchors shall not be used. No powder actuated fasteners shall be used. All fasteners shall be screw in type fasteners.
 - Sheet rock screws of any type shall not be used.
 - Fastening methods shall be subject to approval by UA Electrical Engineer.
 - One hole conduit straps shall be Mineralac Med series or equal.
- LIGHT FIXTURE SUPPORTS in drop ceilings
 - Small incandescent or down lights to have one support wire.

- 2 x 2 or 2 x 4 fluorescent to have (2) support wires and earthquake clips.
- Support wires to be not less than 12 gauge galvanized steel.
- Deflection on support wires to be not more than 30% except where approved by U of A.
- All support wire connected to structure.
- Anchors in concrete to be not less than 1/4" diameter. Use only drill in type anchors.
- All other fixtures shall be rigidly supported from the structure.

Part 3 - Execution

- CONDUITS
 - Support on 10' centers and within 18" of boxes connector, couplings or equipment and 36" of a change in direction.
 - Support from structure.
 - Use strut frame or angle iron frame when no wall system is available.
- LIGHT FIXTURES
 - Support from structure.
 - Support independent of ceiling grid.
 - Earthquake clips.
 - Support from structure to a 500% safety factor
- SAFETY SWITCHES, MOTOR STARTERS, PANELBOARDS
 - Use strut backing when more than 1 is surface mounted in an area.

End of Section 16190

DIVISION 16 - ELECTRICAL

Section 16195 - Electrical Identification

Introduction

To provide ready identification of power source for maintenance personnel.

Part 1 - General

- The following items are to be identified as to source of power:

- Receptacles
- Safety Switches
- Motor Starters
- Junction boxes
- Snap Switches on inside of plate with indelible felt-tip marker

- The following items are to be identified as to what they service.

- Safety Switches
- Motor Starters
- Panelboards
- Switchboards
- Time Clocks

- The following items are to be identified to match the identification indicated on the drawings:

- Panelboards
- Switchboards
- Transformers

- Other items which require identification will be identified in the section pertaining to them.

Part 2 - Products

- For panelboards, safety switches, motor starters, switch boards use black on white plastic engraved identification signs attached using #6 self tapping screws.
- For receptacles use acrylic labels self-adhesive by "Brother P-Touch" Equip. or approved equal.
- For wires use vinyl impregnated cloth tags.
- For color coding cables use vinyl marking tape.
- For j-boxes write in large letters on cover using an indelible magic marker. Where exposed, identification is to be on inside face of cover.
- Panelboards shall have typewritten directories indicating actual room numbers and any other pertinent information for the circuit served. (I.E. COPIER ROOM 131, EF-3, NW CORNER OF ROOF, RECEPTACLES E & W WALLS RM 242). Verify room numbers with University, prior to typing the directories. Use proper room numbers. Note new room numbers on as-built drawings.

Part 3 - Execution

- Require that the new typewritten panel directories be installed after each project or remodel, updated to reflect all changes. Removed panel schedules shall be returned to the UA Electrical Engineer.
- J-boxes for fire alarm circuits shall be painted RED and labeled using an indelible black marker "Fire Alarm".
- Identify ground wires and neutral conductors at all j-boxes, pull boxes, or wherever wires are accessible. Spiral tape continuous where accessible. Ground wires and neutral conductors size #8 and below will have colored insulation.
- COLOR CODES for new work shall be as follows:
- All conductors shall have integral colored insulation.

POWER WIRING

PHASE	120/208 VOLTS 4160/13800 VOLTS	277/480 VOLTS
A	BLACK	BROWN
B	RED	ORANGE
C	BLUE	YELLOW
NEUTRAL	WHITE	GRAY
GROUND	GREEN	GREEN

CLOCK AND BELL

A	BLUE
B	BLACK
C	ORANGE
BELL HOT	RED
BELL NEUTRAL	WHITE

FIRE ALARM WIRING

Refer to Section 16720 (pg. 16720-7)

End of Section 16195

DIVISION 16 - ELECTRICAL

Section 16310 - Primary Switching Station

Introduction

The goal of the electrical department is to provide a looped power distribution system at 13.8 KV Each basic loop is a 400 A loop with available capacity to be able to handle all of the load on the loop from either of two main disconnects at the main distribution system. At present the Primary Pad Mounted (PME) switch is the point where each building is to be disconnected from the loop.

Where located as part of a new construction system the PME switch is to be located at a point that is accessible as far as future connections and for future replacement if necessary. Where for redistribution to an existing system the switch is to be located at a point that is limited in access to the general public, and accessible for future connections.

The designer shall coordinate the medium voltage design with the UA Electrical Engineer.

PME switch should be mounted on a concrete pad with a minimum of 6' clearance in front of all doors, an accessible exit (when the doors are open), and minimum 3' of clearance on both sides for easy access to control switches. The concrete pad shall extend to a minimum of 3' in front of all doors. The concrete pad should contain a grounding ring composed of a 3/4" x 10' copperweld or copperclad ground rod on each corner, connected by minimum of 3/0 ground wire. This ground shall be connected to the ground pad of the PME switch exothermically.

Note: Growth at the University has resulted in fault current availability to exceed the 14 KA value considered maximum for PME style gear. Specify the next higher size rated gear. Check fault values where new switches are to be installed. Consider use of S and C Vista gear. Coordinate with UA Electrical Engineer.

Specify stub-outs for all unused compartments.

Specify 24" bases under all switches.

Specify fuse sizes.

Part 1 - General

- Refer to Appendix Section 16310 and incorporate into project.

Part 2 - Products

- Refer to Appendix Section 16310 and incorporate into project.

Part 3 - Execution

- Refer to Appendix Section 16310 and incorporate into project.

End of Section 16310

DIVISION 16 - ELECTRICAL

Section 16320 - Transformers (High Voltage)

Introduction

Transformers should be mounted on a raised concrete pad a minimum of 4" above the finished floor.

At each transformer a ground ring should be supplied with a 3/4" x 10' copper weld or copper clad ground rod at each corner tied together with a 3/0 copper ground conductor. This shall supply a grounding electrode for the transformer. Exothermic weld grounding electrode conductor to transformer ground pad.

Part 1 - General

- Refer to Appendix Section 16320 and incorporate into project.
- Coordinate new building design to allow for easy removal of distribution transformers from building interiors.
- Transformers shall first be considered for outdoor placement. When indoor placement is approved, provide permanent hoisting and dolly apparatus with egress pathway for easy replacement. Utilize station transformers with a primary knife switch.
- Transformers shall be loop feed with 4-way load break switch. Mount arrestors on the spare bushings. Refer to detail 16320-D1

Part 2 - Products

- Refer to Appendix Section 16320 and incorporate into project.

Part 3 - Execution

- Refer to Appendix Section 16320 and incorporate into project.
- All 13.8 KV equipment not utilized or in use inside or outside a building and its associated wiring shall be removed all the way back to where it originates.

SWITCH TYPE	TYPICAL DECAL STENCIL LAYOUT	VIEW OF CONTACTS FROM FRONT (HANDLE) END OF SWITCH	POSITION 1 FRONT SCHEMATIC AS SHIPPED AND AS SHOWN AT LEFT	POSITION 2 SCHEMATIC SWITCH HANDLE ROTATED 90° CLOCKWISE FROM POSITION 1	POSITION 3 SCHEMATIC SWITCH HANDLE ROTATED 90° CLOCKWISE FROM POSITION 2	POSITION 4 SCHEMATIC SWITCH HANDLE ROTATED 90° CLOCKWISE FROM POSITION 3
T-BLADE MAKE BEFORE BREAK	<p>LINES A & B TO C LINE A ONLY LINE B ONLY TO C LINES A TO B C OPEN</p>					

**FOUR-POSITION SECTIONALIZING
LOADBREAKSWITCH PUB 03047 FOR INCLUSION
IN PAD MOUNTED TRANSFORMERS**

UNIVERSITY OF ARIZONA	
MANUAL OF DESIGN SPECIFICATION STANDARDS	
STANDARD DETAIL:	
4-WAY LOOP FEED SWITCH	
DRAWN BY: C.P.S.	DETAIL NO.:
APPROVED BY: B.COJUSKY	16320-D1
ACAD: 16320-D1.DWG	

End of Section 16320

DIVISION 16 - ELECTRICAL

Section 16390 - Primary Grounding

Introduction

This section applies to the main building grounding electrode system. In general this applies to new building construction or major building expansions only and is not applicable to general renovation projects.

Ground system shall be considered to be separate from the lightning protection system and its associated counterpoise but must be attached to each other. (Typically below grade).

Part 1 - General

- On the Main campus and at AHSC the wiring in the facility becomes a separately derived system as it relates to the distribution system supplied by the power company any time we have a local 4160 volt or 13,800 volt primary transformer. The design of this system should be based on that fact. Grounding shall be per article 250 of the NEC.

Part 2 - Products

- Provide a minimum 50' size 3/0 stranded bare copper conductor in the footing to provide for a base conductor or Concrete Encased Electrode ("UFER") ground for the electrical system. At each end bond out to a 3/4" x 10' copper clad or copper weld ground rod. At each of these points provide an inspection or test point.

Part 3 - Execution

- All primary and secondary service ground connections shall be made using an exothermic welding such as Cadweld.
 - Ground shall be bonded in at least one location to any underground metal water mains or copper water mains.
 - Ground shall be bonded to building structural steel at least one location and per the NEC.
 - The building ground system shall be bonded to any ground ring for lightning protection.
 - Bond to fire protection.
 - Bond to gas.

End of Section 16390

DIVISION 16 - ELECTRICAL

Section 16420 - Service Entrances

Introduction

Service entrance type panelboards and switch gear shall be used wherever the service enters into the facility from the utility serving the facility or where connected to a transformer served from the U of A plant power distribution network.

All new buildings shall utilize service entrance switchboards sized for the load indicated. All Service entrance switchboards should utilize 100% rated power breakers for mains and 80% rated power circuit breakers. Downstream distribution may be from distribution panelboards.

200 – 600 Amperes; electronic with LSI
800 Amperes and up; insulated case with LSI, add G per NEC
1600 Ampere and up; consider use of Pringle bolted pressure switches

Metering at the service entrance shall be as specified by the utility providing the service. For buildings connected to plant power distribution this shall be as specified under division 16430.

At the Main Switchboard or at the service entrance main disconnect switch the neutral conductor shall be bonded to the building or facility grounding electrode system. This system shall be as specified in section 16390 Primary Grounding.

Part 1 - General

- Per NEC 230
- Consultant shall choose major protective device schemes that are easy to coordinate. Consultant shall write into the specifications in **BOLD TYPE** the requirement that a completed coordination study be submitted with the switchboard submittals/service submittals if not in conformance with the basis of design.
Examples:
 - Do not protect 75 KVA transformers with 100 amp fuses, use 200 amp switches fused at 125 amperes.
 - Allow 4 to 1 ratios between motors, motor control centers and upstream devices.
 - Do not size transformers for demand. Downstream main devices must clear before transformer fuses.
 - Refer to IEEE Standard 141 regarding the art of planning systems.
- Switchboard entries shall utilize pull sections that allow main devices to be “top line”, “bottom load”. Make this clear on project drawings. Drawings for projects shall clearly depict the number of switchboard sections.

Part 2 - Products

- Products should be the same as those specified for other divisions of these specifications except that they should meet the requirements of having a means of installing a bonding jumper between the neutral bus and the ground bus. Note that the ground bus should be bonded to the enclosure.

Part 3 - Execution

- The bonding jumper must be a one piece jumper with no splices.

- The service entrance switchboard must be connected to the grounding electrode system. The minimum size of the connection should be per NEC 250-66.

End of Section 16420

DIVISION 16 - ELECTRICAL

Section 16425 – Motor Control Centers, Controllers and Contactors

Introduction

Part 1 - General

- Refer to Appendix Section 16425 and incorporate into project.
- Provide a comprehensive specification.
- Include the following in performing the design and specification:
 - Centers shall be 3 phase 4 wire.
 - Center shall have main disconnecting devices.

Part 2 - Products

- Refer to Appendix Section 16425 and incorporate into project.
- Subject to submittal approval, products known to meet the University's requirements are Cutler Hammer, G.E., Siemens and Allen Bradley.

Part 3 - Execution

- Refer to Appendix Section 16425 and incorporate into project.

End of Section 16425

DIVISION 16 - ELECTRICAL

Section 16430 - Metering

Introduction

Metering shall be provided at the location where each building receives its service. In general the metering shall be located at the main switchboard for the building.

Metering shall consist of a separate meter for each building with local plain language annunciation at the switchboard.

Metering shall be through the use of potential transformers and 3 current transformers located in the main switch board at the building.

Metering shall have the capability of being tied into a separate system where all meters can be monitored from a separate remote control system.

For all new buildings the meters shall be tied into the existing Building Control System.

Part 1 - General

- Metering system shall have the capability of reading KWH, Max KW Demand, KVA, KVARs, Volts, Current, THD Voltage, THD Current frequency and power factor in the same system with the capability of transmitting that data to a central system where that data can be read at a central control station.

Part 2 - Products

- Provide a 1" conduit between the meter and MDF.
- New Switchboard Construction
 - New boards shall be equipped with cold sequence metering. Metering section shall utilize factory installed CT's, PT's and meter. Additionally, the board will be fitted with a VERIS INDUSTRIES meter, switchboard manufacturer installed. The factory metering compartment shall be factory fitted with VERIS INDUSTRIES Hawkeye 8163 Meter and H 8163-CB Communication Board and H8936/8932 Network Display. Contractor or approved equal shall provide rigid/emt raceway from metering compartment to the building MDF telephone terminal board and provide com cable between switchboard meter section and TTB. Provide new RS 485 jack at TTB. Meter compartment shall be dead-front with lugged swing out panel cover. Interior shall have mounting board in place.
- Other Construction
 - New and existing building services without switchboards shall be equipped with the VERIS system described for switchboard systems. Where existing space will allow, provide a CT com. On new construction provide a CT com.

Part 3 - Execution

- All programming for setup of meters shall be supplied and accomplished as a part of the contract. Set intervals so as to store 1 year of KW demand data.
- An identification tag shall indicate any and all multipliers at each meter. Tag shall be an engraved tag with minimum of 1/4" high letters and secured to switchboard using either screws or rivets.
- Incorporate the following diagram, 16430-D1, into the project drawings.

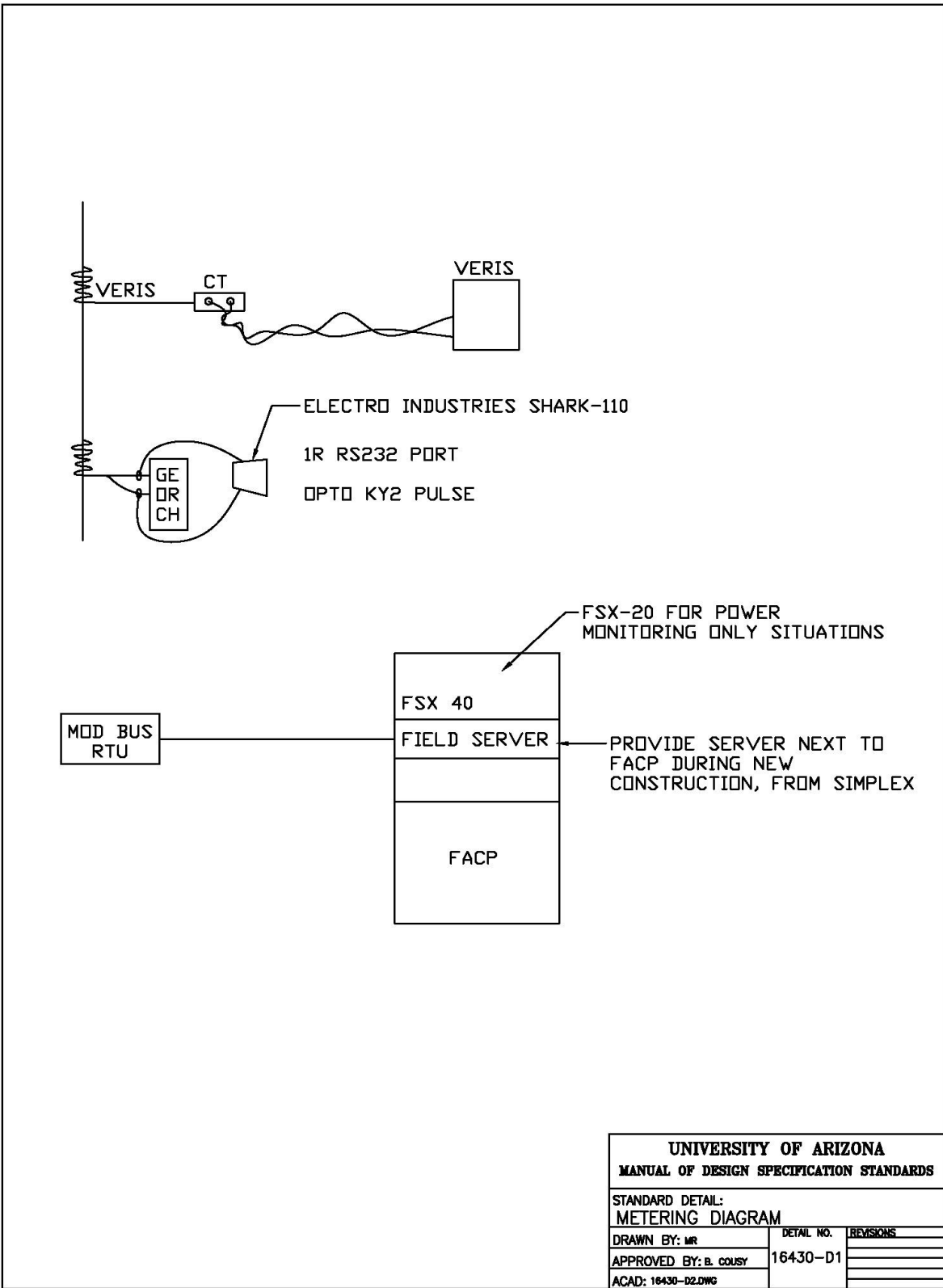

End of Section 16430

DIVISION 16 - ELECTRICAL

Section 16435 – Switchboards

Introduction

There are unique University requirements.

Part 1 - General

- Refer to Appendix Section 16435 and incorporate into project.
 - Provide a comprehensive specification.
 - Include the following in performing the design and specifications.
 - Pull sections shall be required.
 - Top of main device shall be line side.
 - Sections shall have steel barriers or galactic barriers between each section.
 - Metering shall be cold sequence.
 - Metering shall be Veris as specified in Metering Section 16430.
 - Suppressor shall be hard bussed and mounted in it's own cubicle.
 - Areas next to last section shall be planned and marked on the floor for future extension. Provide the housekeeping pad now.
 - Integrated switchboard design is discouraged unless required by the UA Electrical Engineer.
 - Bussing and system design will address coordination of devices. Designer shall provide 4 to 1 separation on motor feeder devices and transformer feeder devices, when referenced to the upstream device.
 - Transformer feeder breakers shall be electronic, and coordinated to the transformer and its inrush.
 - Consultant shall base initial coordination on Cutler Hammer, General Electric, Seimens or Square D.
 - Provide electronic type breakers on devices below 200 amperes whenever clean coordination cannot be achieved, including elevator feeder breakers.
 - NEMA 1 Construction with sprinkler shield.

Part 2 - Products

- Refer to Appendix Section 16435 and incorporate into project.
- Approved manufacturers, subject to submittal review are Cutler Hammer, General Electric, Siemens and Square D.

Part 3 - Execution

- Refer to Appendix Section 16435 and incorporate into project.
- Edit carefully, as required for the project.

End of Section 16435

DIVISION 16 - ELECTRICAL

Section 16440 - Disconnect Switches

Introduction

Disconnect switches shall be used where required to meet OSHA standards for a disconnecting means within line of sight and no more than fifty feet of the actual piece of equipment being controlled.

All disconnect switches shall be heavy duty motor rated switches.

All disconnect switches required for compliance with OSHA shall be lockable.

A disconnect switch is not to be used as a substitute for a motor starter but should be used in conjunction with all motor starters where required as a disconnecting means.

Part 1 - General

- Acceptable manufacturers should include GE, Square D, Seimens, Cutler Hammer, Allen Bradley and approved equal.

Part 2 - Products

- Safety switches shall be heavy duty motor rated with fuses provided to protect downline equipment where required.
- NEMA 3R Environments shall be specified as NEMA 3R/12 gasketed.

Part 3 - Execution

- The maximum mounting height for safety switches should be 6'0" to the top. Safety switches should be rigidly mounted in place.
- Must be readily accessible per NEC
- Label per Section 16195

End of Section 16440

DIVISION 16 - ELECTRICAL

Section 16450 - Secondary Grounding

Introduction

This section shall cover all grounding from the secondary of the main supply transformer OR service entrance main disconnect and all wiring downstream of that point. All systems where the possibility of shock exists due to the lack of grounding shall be grounded.

ALL CONDUITS CONTAINING WIRING TO BE ENERGIZED AT OVER 90 VAC SHALL CONTAIN A SEPARATE GROUNDING CONDUCTOR SIZED PER NEC.

Part 1 - General

- As a minimum per NEC 250.
- Use grounding bond bushings for all *feeder* conduits at panelboards, switchboards, wireways, bus ducts, transformers, generators, transfer switches and any other distribution equipment.
- At panelboards only line conduits shall be required to be bonded. Load conduits for subfeed panels will also need to be bonded at each panel.
- *Wherever grounding requirements are stated in specifications, consultant shall insert requirement that contractor shall submit variance requests in writing and receive approval prior to proceeding with the variance.*
- *Refer to Drawing 16450-D1 on page 3 of this Section.*

Part 2 - Products

- All grounding conductors shall be stranded *insulated* copper wire *except factory tails*.
- Minimum size ground conductor to be #12. Size to be as per NEC.
- All busducts shall contain a separate copper ground bus. This shall be bonded to the enclosure.
- *Receptacle or switch bonding jumpers may be factory crimped stranded assemblies or field assembled with #12 insulated solid conductor.*

Part 3 - Execution

- All grounding conductors shall be color coded green. This must be visible at all visible locations such as in panelboards, cabinets, enclosures, boxes, wireways, etc.
- Isolated grounding conductors shall be green with an orange *or yellow* tracer.
- All light fixtures shall be grounded via a ground screw in the body of the fixture. The ground screw shall not be attached to a removable entrance fitting.
- All enclosures shall be grounded.
- All j-boxes shall be grounded.
- All panelboards shall contain separate isolated neutral and ground busses. An additional isolated ground bus shall be provided where required.
- All enclosures shall be connected to the grounding conductor.

- All conduit systems shall be connected to the grounding conductor.
- Bond transformer neutral to ground at the secondary of the transformer. Do not bond at any other location. An additional ground from the building ground system shall be supplied with the size as per NEC.

DIVISION 16 - ELECTRICAL

Section 16460 - Transformers (Low Voltage)

Introduction

This section covers transformers with primary voltages to 480 volts and secondary voltages to 120/208.

Locate transformers in an area where they are accessible for inspection on a periodic basis. All transformers are to have both secondary and primary circuit protection.

Final connection to transformers shall be in sealtight or steelflex. Minimum length shall be 3'. Conduit shall be left with an ample vibration loop.

Transformer 30 KVA and larger are to be mounted on ground level with a 4" concrete housekeeping pad.

Transformers may be stacked with proper clearances and prior approval of the UA Electrical Engineer.

Part 1 - General

- Transformers are to be as manufactured by PowerSmith, or approved equal.
- Contact UA Electrical Engineer for current listing of approved transformers.
- All approved units shall have been in normal production for a period of two years prior to bid date.

Part 2 - Products

- Provide 4 - 2 ½ % taps on each transformer 10 KVA and above. Two above rated voltage and two below rated voltage.
- Transformers shall be harmonic mitigating type. 3rd harmonic removal shall be considered in design. UA will consider other types of equipment to accomplish 3rd harmonic removal.
- Noise levels shall be 3 db below NEMA Standards, using the lower level NEMA parameter.
- Products shall be energy conserving type TP-1, or better and shall meet the latest DOE efficiency standards
- All protection shall be external to the transformer.

Part 3 - Execution

- Ground transformer neutral to building steel or approved grounding electrode system where building steel is not available.
- Bond frame of transformer.
- When transformers are wall mounted they are to be mounted using factory constructed support assemblies or prior approved supports.

End of Section 16460

DIVISION 16 - ELECTRICAL

Section 16465 - Busduct

Introduction

Busduct should be used where it can effectively replace wire and cable at a competitive rate, or where it is needed to give an area a flexible distribution system.

Part 1 - General

- Acceptable manufacturers are GE, Cutler Hammer, Seimens or approved equal.

Part 2 - Products

- All busducts shall be copper bus with a steel, nonventilated enclosure.
- Shall include full size neutral.
- Shall include a half size copper ground. The duct case shall not be the system ground bus.

Part 3 - Execution

- Support on 5' centers and within 18" of any change in direction, to building structure and as required by manufacturer.
- Support at Tap box or terminal box connection.

End of Section 16465

DIVISION 16 – ELECTRICAL

Section 16470 - Panelboards

Introduction

Design and/or replace panelboards in a manner that provides for expansion for future requirements. For this reason no panel (as a part of the original design) should have more than 60% of the panel filled.

Panelboards shall be readily accessible where located for use by the maintenance personnel.

Wherever possible we would like to see them isolated from view of the general population in localized electrical closets so that unauthorized persons can not operate the breakers.

The general size and construction of the panelboard should be per the required load of the area plus at least 30% spare capacity (calculated).

Minimum AIC ratings for the panel should be 10,000 AIC for 120/208 volt panels, and 14,000 AIC for 277/480 panelboards. All AIC Ratings shall be calculated and displayed on drawings. Series rating is not allowed except with approval of the UA Electrical Engineer.

No Load centers.

Must be readily accessible.

Do not install in doorways.

All circuits from multi pole breakers shall terminate in a single device or piece of equipment. Do not tie more than one receptacle from a multi pole breaker.

Main Breakers shall be fully electronic LSI type. Equal to Cutler Hammer digitrip OPTIMA.

Part 1- General

- Submittals will be required on all panelboards. Suggested manufacturers are GE, Cutler Hammer, Siemens or approved equal.

Part 2 - Products

- All busses shall be full capacity copper.
- Full capacity neutral bus.
- Computer rooms or areas with intensive (200% rated) electronic equipment shall use oversized neutral bus.
- Ground bus isolated from ground.
- Door in door piano hinged front panel.
- Factory installed main breaker with bolted connections to the enclosed bus bars.
- Main circuit breaker required where source is not within line of sight.
- 20" wide minimum cabinets.
- Cans shall be galvanized steel with blank end walls. Knockouts to be field punched.

- 120/208 volt panels shall have bolt on circuit breakers.
 - 100 A panels shall be a minimum 30 circuit.
 - 125 to 225 A panels or larger should be minimum of 42 circuit.
 - Panel sizes shall be based on full size breakers.
 - Back fed mains are unacceptable.
- 277/480 panels and distribution panelboards, shall have bolt on type circuit breakers.
- Use plated bus in NEMA 3R applications.
- Multi pole breakers shall be manufactured for that purpose and shall not be single pole breakers tied together.
- Series rated equipment shall not be used unless approved by UA Electrical Engineer.
- Distribution panelboards shall utilize fully electronic circuit breakers, LSI for sizes 100 amperes and larger.
- Fusible panelboards are not permitted.

Part 3 - Execution

- Support to 500% safety factor.
- For panels mounted flush in walls provide 1 spare 1" conduit per each 3 spare circuits or spaces. Route spare conduits to above lights or to an accessible location.
- Provide Plastic Laminate Label per Section 16195.
- Mount flush wherever possible if not in electric room or equipment room. When installing in an existing building either cut into existing wall and properly support or fir out the wall.
- Maximum mounting height 6'7" to highest breaker (center line).

End of Section 16470

DIVISION 16 - ELECTRICAL

Section 16475 - Overcurrent Protective Devices

Introduction

The general philosophy regarding the application of protective devices is that the circuit breaker or fuse at the source must be sized to protect the wiring. The motor protective device (overloads on a motor starter) should be sized to protect the motor (except where permitted under other sections of the NEC). Where a combination motor starter is used, it is preferred that a fused disconnect be utilized rather than motor circuit protectors. (Both for single units and motor control centers).

Wiring should be always sized to be adequate to serve the load served. The maximum rating of the protective device upstream of the wiring should never be higher than the 75 °C column of Table 310-16 of the NEC or as appropriate for the actual equipment being utilized.

The AIC rating of the protective device must be adequate for the available short circuit of the devices being used. Therefore it is imperative that with each design where the primary distribution to a building is being modified that a proper short circuit calculation be made and applied to the design. Where the short circuit rating of downstream devices is not adequate for the available short circuit current then either the downstream devices must be replaced with higher AIC rated devices or current limiting devices must be used.

The load analysis for the building should be calculated each time a modification to the building loading is done so that a general building overload or a feeder circuit overload will not occur due to inattention to this detail. Should the new loads introduce a situation which would cause either a building or a feeder overload then the Engineer should discuss the situation with the UA Electrical Engineer.

On new facilities all circuit breakers from the main to the 120/208 volt panelboards shall be coordinated and a copy of the coordination study provided to the UA Electrical Engineer during the construction of the facility but prior to ordering any electrical gear

Part 1 - General

- Circuit breakers shall be of the same manufacturer as that of the panelboard or switchboard in which it is manufactured.
- For new equipment circuit breakers shall be either GE, Cutler Hammer, Siemens, or prior approved equal.
- Fuses shall be as manufactured by BUSS, Littlefuse, or prior approved equal.

Part 2 - Products

- Circuit breakers shall be appropriate for the equipment in which they are being installed.
- 10,000 AIC minimum for 120/208 volt systems.
- 14,000 AIC minimum for all 277/480 volt systems.
- The actual ratings shall be as per the short circuit analysis for the appropriate building.
- Circuit breakers for new 120/208 volt panelboards shall be bolt on type.
- Circuit breakers for new 277/480 volt panelboards shall be bolt on type.
- Fuses shall be dual element time delay type fuses.
- Minimum AIC rating for fuses to be 200,000 AIC.

- Panelboard main breakers, panelboard branch breakers 100 amperes and larger, distribution panelboard breakers, and switchboard breakers shall be fully electric type. These breakers shall have at least 5 levels of adjustment, equal to Cutter Hammer “Digitrip OPTIM”. Where 5 levels are not sufficient for CLEAN coordination, the 10 levels of adjustability of the Digitrip OPTIM – 1050 is required. Enhanced thermal magnetic breakers are not to be used and will not be considered. **THIS PARAGRAPH SHALL BE INCLUDED IN ALL SPECIFICATIONS PREPARED BY ENGINEERING CONSULTANTS.** This information shall also be passed on to bidders in situations where contractors, such as CM at risk contractors, are formulating budgets during the early stages of project development.
- All switchboards shall have electronic interlocks for selective tripping.
- All fuses for new equipment shall be rejection type fuses with approved rejection pins at all disconnects.

Part 3 - Execution

- Where multiple breakers are indicated on the drawings they shall be provided with a common trip and not as separate breakers “strapped” or “tied” together.
- Fuses shall be installed in such a manner that the fuse rating can be read from the front of the panel or switch without having to remove or rotate the fuse.

End of Section 16475

DIVISION 16 - ELECTRICAL

Section 16485 - Lighting Controls and Contactors

Introduction

The goal is to provide a standard Lighting Control system with ease of installation and maintenance. The removal of line voltage at the user level is also a safety consideration. The system should be able to continue to operate in the event that the control panel has a failure without impacting the operation of the building users. In addition, the controls shall be networked to allow for offsite access and control without the use of proprietary software and hardware. The system shall also interface with the building automating system (BMS) and be Niagara AX protocol compatible.

Part 1 - General

- Basis of design shall be the Wattstopper DLM series Controls. Designers shall provide submittals for approval for other systems.
- Manufactures Commissioning Agent shall provide access usernames and passwords to access the program and shall provide a back-up media for restoring the control programming to its original state in the event of complete loss of the programming.

Part 2 - Products

- All controller shall have manual override switches.
- Control Architecture shall be a “Buttom Up” type where the individual rooms shall be autonomously controlled and report status back to the controller.
- All relays, contactors and control power backs shall be rated for the overcurrent device protecting the circuit and the load that is being controlled.
- All controls shall be compatible with the lighting ballasts, drivers etc. that are being controlled and shall be coordinated during design.
- All lighting controllers shall be compatible with the Building Management Systems and shall communicate with the network without external translators.
- No system shall be designed that requires proprietary software or offsite Tech support for any reprogramming or systems diagnosis.

Part 3 - Execution

- Lighting control design shall be kept as simple as possible such that a failure of a component does not disable the entire system.

End of Section 16485

DIVISION 16 - ELECTRICAL

Section 16510 - Lighting Design

Introduction

Lighting utilizes approximately 40% of the electrical energy consumed here at the university. In order to conserve the energy it is very important that the lighting design be energy efficient. Soffit lighting must be accessible.

Consideration for maintenance of the light fixtures needs to be taken into account also. If a lamp is known to have a short life or a fixture manufacturer is known for having problems with his equipment make sure to eliminate them from consideration as a manufacturer. Use linear type fixtures whenever possible. Recessed compacts are to be minimized. Long lead, specialty lighting shall be avoided and where the design team request a variance the final approval is by UA Electrical Engineer.

Light levels should be appropriate for the task and per the following guide in Part 1 - General.

Design Guidelines

- Lighting design shall comply with current IESNA guidelines and application notes, with selection of the median illuminance as the target optimum, not the minimum. In all areas designated higher than IESNA category C, specified illuminance shall be on task, with ambient illuminance generally task/3. In all areas, lighting targets shall be achieved by the most current energy efficient technology which meets the requirements of this Section 16510.
- Incorporation of natural daylight, and daylight-supplementing artificial light.
- Area lighting by high-CRI linear tube fluorescent with specular reflectorized interior luminaire. For applications which do not involve frequent switching, use fully electronic instant start parallel-circuit ballasts.
- Task lighting by LED lamps with laterally offset placement so as not to cause direct or veiling glare.
- Conference room dimming: provide continuous architectural-dimming (to 10%) with linear fluorescent luminaires or LED fixtures in place of incandescent can downlights. Fluorescent dimming should be avoided where possible and use in limited spaces. UA Electrical Engineer shall approve fluorescent dimming.
- Reflectorized technologies for interior luminaires.
- Areas with visible daylight may use continuous-dimming photocell-controlled variable light output devices except those controlled by non-defeatable occupancy sensors. Daylighting contribution to be considered in calculation of IESNA target illuminance.
- Fluorescent lamps must meet the Federal TCLP mercury limit of 0.05mg./L
- LED lighting is encouraged as applicable to the desired lighting result. Utilize high quality fixtures with proven industry records for endurance.
- T-8 fixtures and lamps shall not be used unless with prior approval of the UA Electrical Engineer

Prohibited technologies include:

- Rapid start systems (non-dimming applications)
- Tungsten filament incandescent except quartz-halogen
- T12 fluorescent
- VHO and SHO lamps
- Mercury vapor lamps
- U-shaped lamps (except for CFLs)
- Small-cell paracube grates and large cell paracube fixtures where the lamp is not centered into the cell
- Magnetic fluorescent ballasts
- Series-circuit ballasts
- Indirect lighting in restrooms, corridors, and utility areas
- Neon systems of any type

Vacancy Sensors shall be specified and installed in accordance with EPA Green Lights guidelines, with control technology appropriate to the application. Areas with video display terminals shall be primarily illuminated by task lighting, use of overhead luminaires in each space to be evaluated for Visual Comfort Probability. Visual acuity factors are to be treated as minus weighting factors.

Discouraged Practices

- Indirect cone and soffit lighting
- Fixtures inaccessible from a landing or walkway.

Two level Lighting control should be provided in areas where multi use of the area would require various levels of light control. Where a greater variation on the lighting is required then the use of linear fluorescent fixtures with electronic dimming ballasts or LED fixture are is preferable as far as energy consideration than the use of incandescent fixtures with dimmers

Minimize the use of incandescent and quartz halogen type light sources since they are both expensive to operate (in both energy and heat gain) and maintain. Prior approval from the UA Electrical Engineer must be obtained prior to design using either of these light sources.

Where remodeling is being done in an area it shall be considered to be part of the scope of work to bring the existing lighting in the area into compliance with this section.

In both new lighting and remodeling type lighting projects it shall be required to perform lighting calculations for the proposed systems and to submit point to point, area and lighting density calculations. Provide cut sheets for the fixtures proposed as a part of the schematic design of the project.

Part 1 – General

- Contractor to provide submittals of all light fixtures, with actual ballast type when applicable, and lamp types utilized.

- **Lighting Levels**

The following information shall be used by the designer in developing a lighting system for each specific project based on IES recommended practices, codes and ordinances, life safety requirements and good engineering practices. Major deviations due to engineering decisions shall be documented in writing and discussed with the UA Electrical Engineer during the design development stage or schematic design stage. When in doubt, call for a presentation by the University.

- **University Lighting Standards**

Lighting levels at desk or tables tops shall be:

Hallways: 25 foot-candles average maintained foot-candles
Public areas: 30 foot-candles average maintained foot-candles.
Offices: 50 foot-candles average maintained foot-candles.
Reading rooms: 50 foot-candles average maintained foot-candles.
Classrooms: 50 foot-candles average maintained foot-candles.
Laboratories: 70 foot-candles average maintained foot-candles.
Machine Shops/Workshop: 100 foot-candles average maintained foot-candles.

Minimum lighting standards shall be defined as average maintained foot-candles (within the range of -10% to +25%) over the life of the lamps, unless otherwise pre-approved by the University.

• **Preferred Lighting Densities**

The maximum lighting power density (LPD) for any building may be calculated by either the Complete Building Method (Table 2.1) or the Area Category Method (Table 2.2)

**Table 2.1
Complete Building Method**

Building Type	Max. Lighting Power Density (W/sf)	
	Goals	Max *
General Commercial or Industrial Work Buildings	0.8	
Grocery Stores	1.2	
Industrial or Commercial Storage Buildings	0.5	.8
Medical Buildings and Clinics	1.0	A.R.
Office Buildings	1.0	1.8
Religious Worship, Auditorium/Convention Centers	1.3	A.R.
Restaurants	1.0	
Retail and Wholesale Stores	1.3	A.R.
Schools	1.2	
Theaters	1.0	
All Others	0.5	

*AR means "as required"

**Table 2.2
Area Category Method**

Area Type	Max. Lighting Power Density (W/sf)	
	Goals	Max *
Auditorium	1.3	A.R.
Bank and ATM's	1.2	1.8
Classrooms	1.3	1.8
Convention/Conference/Meeting Centers	1.0	2.0
Corridors, Restrooms, Support Areas	0.5	
Dining	0.8	1.4
Exhibit	1.5	2.0
General Commercial and Industrial Work	0.8	A.R.
Grocery	1.3	A.R.
Hotel Function	1.5	
Industrial and Commercial Storage	0.4	1.8
Kitchen	1.5	
Lobbies: Hotel Lobby	1.5	
Main Entry Lobby	1.0	
Malls, Arcades, and Atria	0.8	
Medical and Clinical Care	1.2	A.R.
Office	1.0	1.8
Precision Commercial and/or Industrial Work	1.3	A.R.
Religious Worship	1.4	
Retail Sales, Wholesale Showrooms	1.4	
Theaters: Motion Picture	0.7	
Performance	1.0	A.R.

* AR means "as required"

Part 2 – Products

- Light fixtures are to be the product of a manufacturer of high quality light fixtures generally used in an industrial or commercial type setting. Fixtures shall be UL or CSA listed and certified.

Fluorescent fixtures shall utilize electronic ballasts (not hybrids). Ballasts shall be Advance, Universal/Magnetec or prior approved equal as manufactured. All ballasts shall be CBM certified. Crest factor shall be not greater than 1.7. Harmonic distortion shall be less than 10%. Ballasts/ fixtures shall have internally mounted code conforming disconnect devices.

- Linear fluorescent lamps for 4' or 8' fixtures shall be type T8 32 or T5 28 watt 4 ft. lamps (tandem 4' lamps in 8' fixtures) energy saving lamps and shall be compatible with the type of ballasts supplied (and must be certified as such by both the manufacturer of the lamps and the manufacturer of the ballasts).
- Lamps shall be 3500°K with a CRI of 85. New buildings shall utilize 3500°K lamps. Lamps shall be rated for 24,000 hrs. minimum. Lamps shall be non-hazardous and disposable by normal means.
- For smaller than 4' lamps it is recommended that compact biax lamps be utilized rather than the use of u-tube type lamps. (48" U tubes are not permitted.)
- Ballasts shall be installed such that they are contained within the fixture. Where this is not possible the ballast shall be installed clear of any combustible material and in an accessible location. Ballasts for recessed non-linear type fixtures shall be located between the fixture housing and the junction box.
- Where HID type fixtures are used utilize ballasts without igniters and specify that the igniter be integral with the lamps.
- All ballasts for HID fixtures shall be high power factor/low noise/low emf type ballasts.
- Compact fluorescent ballasts shall be highest quality, HPF, minimum THD and maximum efficiency.

Part 3 – Execution

- Light fixtures shall be installed so that they are accessible for maintenance.
- Reference 16190 for supports.
- Fixtures mounted in a plaster or drywall type ceiling shall be rigidly supported in an approved manner using channels connected to the ceiling support system
- Provide plaster frames for all fixtures requiring them.
- Light fixtures mounted flush in fire rated walls or ceilings shall be rated to the wall/ceiling rating.
- 3/8" light fixture whips may be utilized when fixture whip comes from the factory attached to the fixture via a steel box connection. Wire size shall not be less than #18 THHN. Box connectors must have a locknut, i.e., pop in type connectors will not be permitted. Lengths shall not exceed 6'0". (Tandem whips may be longer with University approval.) Whip will be secured within 18" of J-box.
- Removable snap in entrance fittings shall be secured to the fixture body using a #8 (minimum) self tapping screw.
- 2x2; 2x4; 1x4; 1x6 and 1x8 types of light fixtures including recessed can type fixtures installed in grid ceilings shall be supported using not less than #12 gauge steel galvanized support wire and earthquake clips shall be installed. Each rectangular or square type fixture shall have a minimum of two support wires attached at opposite corners. Each recessed can type fixture shall have a minimum of one support wire. Support wires

shall be secured attached directly and independently to the building structure with minimum size ¼" galvanized steel anchors (use expansion type anchors when in concrete). Wires shall have a minimum of three twists (turns) at each attachment point. Deflection on the support wires shall not exceed 10-degrees from plumb. Refer to Section 16190 – Supports – LIGHT FIXTURE SUPPORTS.

End of Section 16510

DIVISION 16 - ELECTRICAL

Section 16530 - Site Lighting

Introduction

When designing site lighting for the University two areas of major concern arise. The first and most prominent is that of safety for the students and faculty members. Since many times students need to be out and around the facility at late hours it is important to provide lighting such that they can see well enough to feel safe when they are traveling from one building to another.

The second area of concern is to minimize site lighting so as to meet within the guidelines for both Kitt Peak and Mt. Hopkins Observatories.

Lighting design should be in keeping with IES Lighting Standards and the Pima County Lighting Ordinance. Follow the ordinance. Special situations may receive a variance. Submit written requests to the University for written approval.

As a part of the design we expect to see details of both bollard and light pole foundations. Foundation designs shall be sealed by a Structural Engineer.

Metal halide shall not be used unless approved by UA Electrical Engineer.

Low pressure sodium sources are not to be used. High pressure sodium, fully shielded is the preferred source.

Light fixtures should be located in such a manner that they can be easily maintained using standard equipment. Where fixtures can not be easily accessed the use of hinged poles shall be required. All exterior building light fixtures and poles shall be readily accessible and not restricted by other site improvements.

The design should be made in a manner such that is both energy efficient and cost effective as well as meeting the requirements for the local regulations.

The design should be flexible for both the field installation for expansion and for maintenance.

Where large areas are involved provide handholes for maintenance use to trouble shoot the underground wiring when needed, and to allow for easier expansion if required in the future.

As part of the design development phase provide cut sheets and point to point design calculations for all site lighting.

Where site lighting is to be designed either on the fringes of campus or off campus, insure that no light trespass occurs.

Refer to section 02870; as it pertains to street lighting.

Ingrade lighting shall be avoided.

Part 1 - General

- Provide submittals on all fixtures, including poles, bases, and ballasts at the Schematic Design Phase.
- Pole foundations are required for all lighting poles. These shall be engineered concrete foundations, engineered by a structural engineer, registered in the State of Arizona.
- All metal parts of lighting systems shall be bonded to ground. This includes the steel rings on concrete pull boxes.

- Pole foundations shall be grounded with 20 ft. of bare #2 copper wire buried below the concrete foundation.

Part 2 - Products

- Provide high quality products which are both architectural in nature and have an efficient lighting design.
- Use enough fixtures to provide adequate light especially in exterior corridors or areas between buildings to allow proper levels for personnel safety.
- Where available match fixtures in surrounding areas to be able to allow some continuity with the lighting in a general area.
- Light poles need to be designed for a minimum of a 100 mph wind loading. (80 mph + 1.3 gust factor)
- All pole mounted fixtures shall be fused and shall be breakaway type.
- Pole mounted fixtures shall have fuses in base of pole with handhole access.
- **Part 3 - Execution**
- Include requirements for aligning light fixtures, light poles, and bollards to be both level and uniform in layout and light distribution.

End of Section 16530

DIVISION 16 - ELECTRICAL

Section 16535 - Emergency Lighting

Introduction

Provisions for emergency lighting should take into consideration the requirements for location of emergency exit lights in accordance with the new ADA and the requirements of the NFPA for exit lights.

In general for new buildings it is required that all emergency lighting be supplied through the use of an electric generator. Each floor should have its own emergency panel and all emergency lights should be supplied from that panel.

On existing buildings where an emergency generator exists, all new emergency lights should be connected to that system. On buildings without an emergency generator system utilize 2 hour emergency battery packs in fixtures where required.

Do not wire light fixtures with power from two different emergency power systems.

For corridor emergency/night light circuits consider using florescent fixtures with PL type lamps at either 13 or 26 watt levels or LED.

Emergency lights located in classrooms or labs where a fully lit fixture would cause problems with the capability to darken the room (where a dark room is necessary for the room's operation) shall be switched via a lighted red toggle switch.

Part 1 - General

- Provide submittals on all emergency light fixtures.

Part 2 - Products

- Emergency or exit lights shall be the LED type low power use.
- Clear plexiglass exit signs, if used, shall have factory backings to prevent reading the words backwards.
- Battery packs should use the Nicad type batteries with a minimum of 10 year life.
- Where emergency lights contain battery packs the emergency ballast shall be as manufactured by Iota or approved equal.
- Fluorescent fixtures with 4 ft. lamps shall utilize 1000 lumen battery packs when battery packs are permitted.
- HID Lighting shall not be used for emergency lighting.

Part 3 - Execution

- Where used in classroom situations it is generally considered that all emergency lights should be capable of being turned off via normal light switches. However in case of an emergency or loss of power, and where possible they shall all be energized to illuminate the means of egress. Emergency lights shall be supported by the same criteria as normal light fixtures. Use necessary relay and control circuitry to accomplish restoration of emergency and egress lighting.

End of Section 16535

DIVISION 16 - ELECTRICAL

Section 16580 - Theatrical Lighting

Introduction

Since theatrical lighting is a very specialized lighting system it should be left to be designed by experts in this field of lighting. On projects such as this it is required that the engineer responsible for this area of design be experienced in this type of design and should provide documentation in the form of past projects engineered which would back up his claim.

Documentation required on this type of design would be providing a minimum of two proposals for the type of design proposed. Each should include back up information such as type of equipment planned (including cut sheets), typical life expectancy of equipment (including bulbs and ballasts where applicable), and cost estimates for each type of lighting system.

Design should take into account the requirements of maintenance on the system and the reliability of the equipment. For this reason we would expect to have included in the design high quality equipment by the top manufacturer's of this type of equipment.

Theater design should include design calculations and computer printouts on a point to point basis. Cut sheets of intended products shall be provided at the design development phase.

The electrical consultant shall supervise the lighting design and seal the plans.

Part 1 - General

- Complete submittals of all equipment proposed should be provided.
- Maintenance and operational manuals should be provided (minimum of 4 sets) at completion of project.

Part 2 - Products

- All products should be the product of top quality manufacturers and should be designed for the purpose for which it is used.
- All products should be U.L. listed or certified.

Part 3 - Execution

- All equipment should be independently supported to a minimum of a 200% safety factor to the building structure.
- All equipment should be located such that it is accessible for maintenance or can be made available for maintenance through normally available methods.

End of Section 16580

DIVISION 16 - ELECTRICAL

Section 16610 - Uninterruptable Power Supply Systems

Introduction

The design of UPS systems is normally associated only with specialized computer room distribution systems. At the present most of these systems are not associated with the renovation of any building or facility, but rather a piece of equipment that would be provided by the user as a separate item. However where they are to be provided by the contractor as a part of the construction package the following guidelines should be taken into account for the design.

- A minimum of a 20 minute battery backup shall be used.
- Only static UPS units should be used.
- Design should provide for a minimum of 30% spare capacity.
- Design shall be based on top quality static UPS systems such as those supplied by Liebert, and similar manufacturers.
- Design for the electric service to the unit should take into account the losses for the system.
- Since these units generate a large amount of heat and are usually somewhat noisy it is recommended that they be located in a room where the general public will not normally be working, where there is adequate air conditioning for the required heat load, and where the walls provide a good deal of noise attenuation.
- The UPS room or area shall be engineered so that the UPS will operate in its environment without overheating. Cool as necessary.
- Equipment shall be front access only.
- Transformerless UPS systems should be considered.

Should this section be required for an actual project please consult with the UA Electrical Engineer.

Part 1 - General

- All systems must be UL listed.
- Provide complete submittals on UPS system including operations and maintenance manuals (minimum of 4 copies).
- Provide for two years of preventative maintenance as a part of the cost of the UPS.
- Specify seismic anchoring of all UPS cabinets. Provide remote status monitoring for all systems.
- Provide external bypass panel.
- Provide monitor panels for unattended UPS units. Connect to a location satisfactory to the PDC Electrical Engineer.

Part 2 - Products

- To be determined at time of design. Suggested manufacturers to be Liebert or approved equal.

Part 3 - Execution

- Install units in an area where they are fully accessible for maintenance, and with adequate ventilation.

End of Section 16610

DIVISION 16 - ELECTRICAL

Section 16620 - Standby Power Generator Systems

Introduction

The design for emergency power generation takes on two separate designs at this campus. For the typical building at the main campus it is generally used only to provide power to emergency lighting and similar building maintenance type pieces of equipment. In some other buildings additional loads are added for such things as freezers or other types of mechanical equipment which need to be on due to worry about losses of expensive equipment (including some valuable experiments) which are stored in the freezers. However the design for expansions on the AHSC campus sometimes take on a different flavor since it may include areas which could someday become part of the hospital. For this reason it will be necessary to discuss in great detail the design of the emergency generation system with the Engineer, prior to the proposal of the system. As a part of the design the following items should be taken into account:

- In general we require that the fuel type for any new emergency generators be #2 diesel. Be aware that we may require natural gas or bio-fuel units from time to time. Coordinate needs with the CPM.
- Make sure that the generator will be adequately cooled in case of loss of power to the general building system. It may be necessary to provide additional capacity for the generator just to cover an additional fan coil unit to provide cooling to the generator room if it is located inside of a closed room in the building.
- Provide for adequate exhaust from the building in a location where the fumes will not be sucked into the building air conditioning system during normal or emergency conditions.

In addition it may be decided that some of the emergency generator systems will in the future be used for peak shedding. For this reason it is important that the generator provided be of a top brand of manufacture and designed for more than just an occasional run emergency operation. Engine generators shall be site tested for rated output plus 10% for 1 continuous hour, connected for temperature, based on capability to operate continuously at 115°C ambient. (Refer to base specification.)

As a part of the design development documents, provide a load calculation which is used for providing the basis for the sizing of the emergency generator. Take into account that at least 30% spare capacity shall be provided for in the design of the emergency generator.

As part of the plans design make sure that the required circuits for the battery charger and the engine oil and manifold heaters are shown and provided.

Remote control or annunciation panels shall be shown on the drawings with all wiring required.

Show ATS (automatic transfer switch) and all associated wiring on the plans. Fire alarm shall monitor generator run and report to Fire Safety Shop thru the Server (Refer to 16430-2).

For your use a copy of an existing specification for an emergency generator specification and an automatic transfer switch have been provided. (See attached appendix specification sections 16620 and 16622). As a minimum all of the areas covered in this specification shall be covered. This specification can be provided on disk for your use, however it is still the responsibility of the engineer to provide a complete specification for this design.

Where a building EMCS system is available connect the following items to the system. Building power off, generator power on, generator alarm (a common alarm of all generator alarm functions).

Part 1 - General

- Provide complete submittals on the emergency generator, including at least 4 copies of all operations and maintenance manuals. Submittal information shall include documentation of fuel efficiency based on a KW per pound of gas. This should be provided for evaluation by the engineer prior to approving the use of any brand of emergency generator set.

- Provide distribution for legally required loads and optional loads as outlined in Article 700,701 and 702 of the applicable NRC-70. This shall include, but not be limited to, telephone equipment, servers, cooling for telephone and server equipment and elevators. (elevators where required by ANSI 17, SFM or ADA)

Part 2 - Products

- The generator should be the product of top quality generator manufacturers such as Caterpillar or Waukesha. Other manufacturers may be considered based on submittal information. The manufacturer should certify that the generator is capable of providing the necessary power for all of the load as designed, including the spare capacity.
- Generator shall have an onboard circuit breaker for load bank testing without having to disconnect the load feeders from the generator.
- Engine Generator System shall have a 5 year extended warranty. Whenever the transfer switch manufacturer offers an extended warranty, it shall be included,
- The contractor shall provide (2) complete sets of parts and repair manuals for all engine, generator and transfer switch systems and components.

Part 3 - Execution

- The generator shall be bolted to a housekeeping pad and if in a building shall have a containment area built around to contain any oil or antifreeze spills. The generator shall be installed and connected to meet with the requirements of the manufacturer.
- Provide a resistive load bank test of all generators prior to acceptance. Minimum tests should show all required control options of the generator and transfer switch as well as a one hour load bank test at 80% load and an additional one hour load bank test at 110% load, corrected for temperature of 115° C. Generator shall also be tested in a full load live situation test prior to acceptance.

End of Section 16620

DIVISION 16 - ELECTRICAL

Section 16622 Automatic Transfer Switch

Introduction

The intent of this section is to require that at each location where an emergency generator system is utilized an automatic transfer switch (ATS) *or bypass isolation transfer switch shall be utilized.*

Since more and more equipment is being added to the system which is "protected" by the emergency generator system it is important that a top quality transfer switch be utilized. In addition it has been found that though many of the manufacturer's of emergency generators can provide a switch in conjunction with the emergency generator that these are usually of a lower overall quality and more subject to breakdown. Therefore we would suggest that the ATS be of similar quality to that in the accompanying specification.

The ATS should be sized to meet both the maximum short circuit current available from the combined sources (in case of a direct fault during transfer), and for 125% of the available current from either the normal or emergency power source *with a 3 cycle rating in excess of UL 1008.*

Since the ATS generally contains electronic items make sure that the location of the transfer switch is compatible (i.e. adequate cooling and minimum dust) with the transfer switch.

A sample specification (see attached Appendix Section 16622) has been provided for your use outlining all of the standard requirements necessary for new installations here. As a minimum all of the items outlined in this specification should be included.

Whenever GFI is used, provide 4 pole switches.

Transfer switch shall have programmable auto exercising feature for once a week

Part 1 - General

- Complete submittals and operational manuals shall be provided as a part of the system.
- The warranty shall be the same as that of the emergency generator that it is associated with.
- Complete maintenance manuals and spare parts lists be provided as a part of the project close out documents.

Part 2 - Products

- Russelectric, or *prior* approved equal. *Zenith and ASCO may be specified after first documenting proof of third party testing for a 3 cycle rating. (Prior to completing contract documents submit proof at design development stage of design).*

Part 3 - Execution

- Startup and check out to be by a manufacturer's certified technician.

End of Section 16622

DIVISION 16 - ELECTRICAL

Section 16650 - Electromagnetic Shielding Systems

Introduction

Electro magnetic shielding is only required when due to the type of testing going on in a building that high levels of electro magnetic fields (EMF) are generated in an area. Typically if personnel are being exposed to levels of EMF higher than 100 mg then electro magnetic shielding should be provided or special consideration should be taken to lower the EMF.

Sometimes it will be necessary to build a specially shielded room for personnel involved in the testing of special systems so as to minimize the amount of EMF and RF (radio frequencies) which would enter the test space.

The design of such a system in either case shall be done only by personnel who are experienced in design of shielded rooms or special shielding facilities. Special grounding systems shall be taken into account to facilitate complete draining of all EMF energies into the ground and thus protect personnel.

Part 1 - General

- Provide complete submittals for the design whether by the engineering firm or a design build concept is used.

Part 2 - Products

- All grounding parts shall be copper. Copper shielding shall be utilized in the design. Where required for personnel protection the entire system shall be UL certified.

Part 3 - Execution

- The installation of the system shall only be accomplished by personnel experienced in the construction of Electromagnetic shielding systems. Following the construction of the system it shall be the requirement of the installer to have the entire system tested to verify that it complies with the minimum design constraints set up prior to the design of the system.
- Foil systems utilizing foil stapled to walls is unacceptable design.
- Consult PDC Engineer for test/compliance of these facilities during design.

End of Section 16650

DIVISION 16 - ELECTRICAL

Section 16660 - Ground Fault Protection Systems

Introduction

All building main distribution systems shall have a ground fault protection system as a part of the secondary main disconnect at the building. This is required per the NEC for services of 1000 amps and larger.

GFI receptacles shall be used for drinking fountains and wherever a receptacle is within 6' of a sink or an emergency shower and where otherwise required by the NEC or good engineering practice.

GFI receptacles shall not be feed through type. Each location required shall have its own GFI receptacle.

It may be necessary to add GFI protection to services where an adequate ground is not available and where danger of electrocution is possible. An example of this would be an overhead crane where only a three wire system has been connected to the service and where the danger of electrocution is greater than the possible danger from loss of power to the overhead crane.

All kitchen receptacles shall be GFCI per the NEC. Refrigerators shall be placed on 30 milliamp GFCI receptacle.

Part 1 - General

- Provide complete submittals for all devices supplied under this section.

Part 2 - Products

- GFI relays provided as a part of a main switchboard shall be as recommended by the manufacturer of the switchboard.
- GFI receptacles shall be heavy duty specification grade receptacles similar to Plug back Hubbell GFRST20Snap.

Part 3 - Execution

- Install all devices in accordance with the manufacturer's recommendations. For service entrance systems the device shall be tested following installation in accordance with NETA testing standards.
- Each GFI receptacle shall be tested for proper operation following installation.

End of Section 16660

DIVISION 16 - ELECTRICAL

Section 16680 - Variable Speed Drive Systems Coordination

Introduction

Refer to section 15870 for VFD parameters and provide coordination to include mechanical trades.

Part 1 - General

- Note that it will be necessary to interface with the mechanical or instrumentation engineer as to what required connections are necessary for the tie into the EMCS or other control system
- Do not locate drive inside of air handling units unless a dedicated power and control space accessible from the exterior is provided.
- Require complete submittals including wiring diagrams and recommended spare parts at the submittal.
- Require submission of complete operation and maintenance manuals at time of completion of contract prior to conducting the "training session". Operation and maintenance manual shall contain a complete copy of the submittal documents.
- Require a factory representative startup and training on site four hour minimum training session to be scheduled after the VFD is in service and fully operational.

Part 2 - Products

- Refer to section 15870
- Fully transistorized PWM type drives.
- Coordinate use of VFD rated motors with mechanical trade.

Part 3 – Execution

- Utilize Mechanical section 15870 in coordination with the mechanical trade and /or engineer.
- Limit length of feeder from VFD or AFC (adjustable frequency controllers) to motor as per recommendations of the manufacturer. If possible locate drive near motor.
- Feeder must be in steel conduit.
- Control wiring in separate steel conduit. Speed signal wiring to be in twisted shielded pair, minimum of 18 ga. copper.
- Install AY.

End of Section 16680

Section 16700- TELECOMMUNICATIONS

Introduction

- The scope includes a complete telecommunication system that includes riser cables, station wiring, terminations, termination devices, grounding and minimum sizes of MDF and IDF rooms.

General

- All Telecommunications requirements for new and existing buildings shall be coordinated with UA Electrical Engineer and UITS prior to the start of design.
- See Appendix for approved Master Specification. Master Specification shall be incorporated into your specification sections.

Products

- See Master Specification and incorporate into your specification sections.

Execution

- See Master Specification and incorporate into your specification sections.

End of section 16700

DIVISION 16 - ELECTRICAL

Section 16705 – Blue Light Phones

Introduction

Auxiliary Systems and Communications related support systems.

Part 1 - General

- This section must be incorporated into each project and coordinated with related sections. These areas include:
 - “Blue Light” emergency phones
 - Telecommunications grounding
- In projects where “Blue Light” emergency phones are required, the installation of the emergency phone unit and mounting pole or wall-mount housing shall be included in the scope of work. Conduit and power shall also be provided for each emergency phone. Electrical outlet shall be installed inside pole for proper disconnect requirements.

Part 2 - Products

- The following are the part numbers for the Blue Light Phones commonly used at the University of Arizona (include verbal descriptions and verify catalog numbers, require submittals):

Hands-Free Emergency Phone: Talk-a-Phone #ETP-400

Mounting Tower (pedestal): Talk-a-Phone #ETP-MT

Wall-mount Enclosure: Talk-a-Phone #ETP-WM

Authorized Product:

TALK-A-PHONE Co.
5013 North Kedzie Avenue
Chicago, Illinois 60625-4988
Phone: (773) 539-1100
Fax: (773) 539-1241
Email: info@talkaphone.com <http://www.talkaphone.com>

Part 3 – Emergency “Blue Light” Phone Systems

- Blue phones shall be mounted on steel pedestals with concrete bases, or in wall-mount enclosures as directed by the project manager with #6 ground ring.
- Instruments shall be “Talk-A-Phone Co.”, Model ETP-400, with blue light mounted above. Refer to University Standard details.
- “Blue Light” phones shall be cabled and terminated at the closet IDF closet. Provide station protectors at the phone unit where required by NEC 800.30. Final cross-connections and phone programming will be provided by U of A, CCIT-Telecommunications.

Consultant to coordinate locations with University Risk Management department.

- Refer to Drawings 16705-D1 and 16705-D2.

BLUE LIGHT PHONE PEDESTAL DETAIL

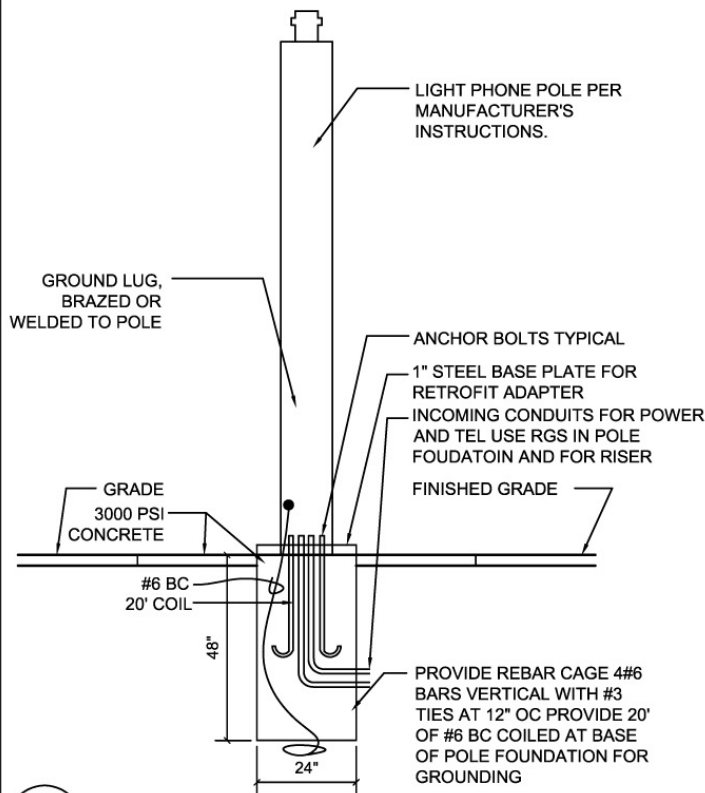

POLE INSTALLATION DETAIL, NEW TOWER, NEW FOUNDATION
NOT TO SCALE

TYPICAL-BLUESTAKE
EACH POLE LOCATION
BEFORE INSTALLATION.
REPAIR ANY DAMAGE TO
EXISTING UTILITIES.
PROVIDE PULL STRING IN
EVERY TELECOM CONDUIT

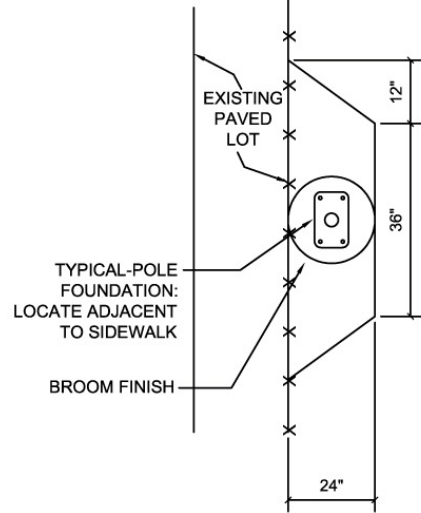

TYPICAL-FOR ADA ACCESSIBILITY POUR 4" SLAB AT GRADE TO DIMENSIONS SHOWN AT EACH LOCATION WHERE SIDEWALK EXISTS.

ADA ACCESSIBILITY DETAIL
NOT TO SCALE

UNIVERSITY OF ARIZONA		
MANUAL OF DESIGN SPECIFICATION STANDARDS		
STANDARD DETAIL:		
BLUE LIGHT PHONE PEDESTAL DETAIL		
DRAWN BY: KML	DETAIL NO.	REVISIONS
APPROVED BY: FD&C	16705-D1	
ACAD: 16705-D1		

BLUE LIGHT PHONE WALL-MOUNT ENCLOSURE

CONTRACTOR SHALL VERIFY WITH EQUIPMENT REQUIREMENTS PRIOR
TO BUILDING A SYSTEM.

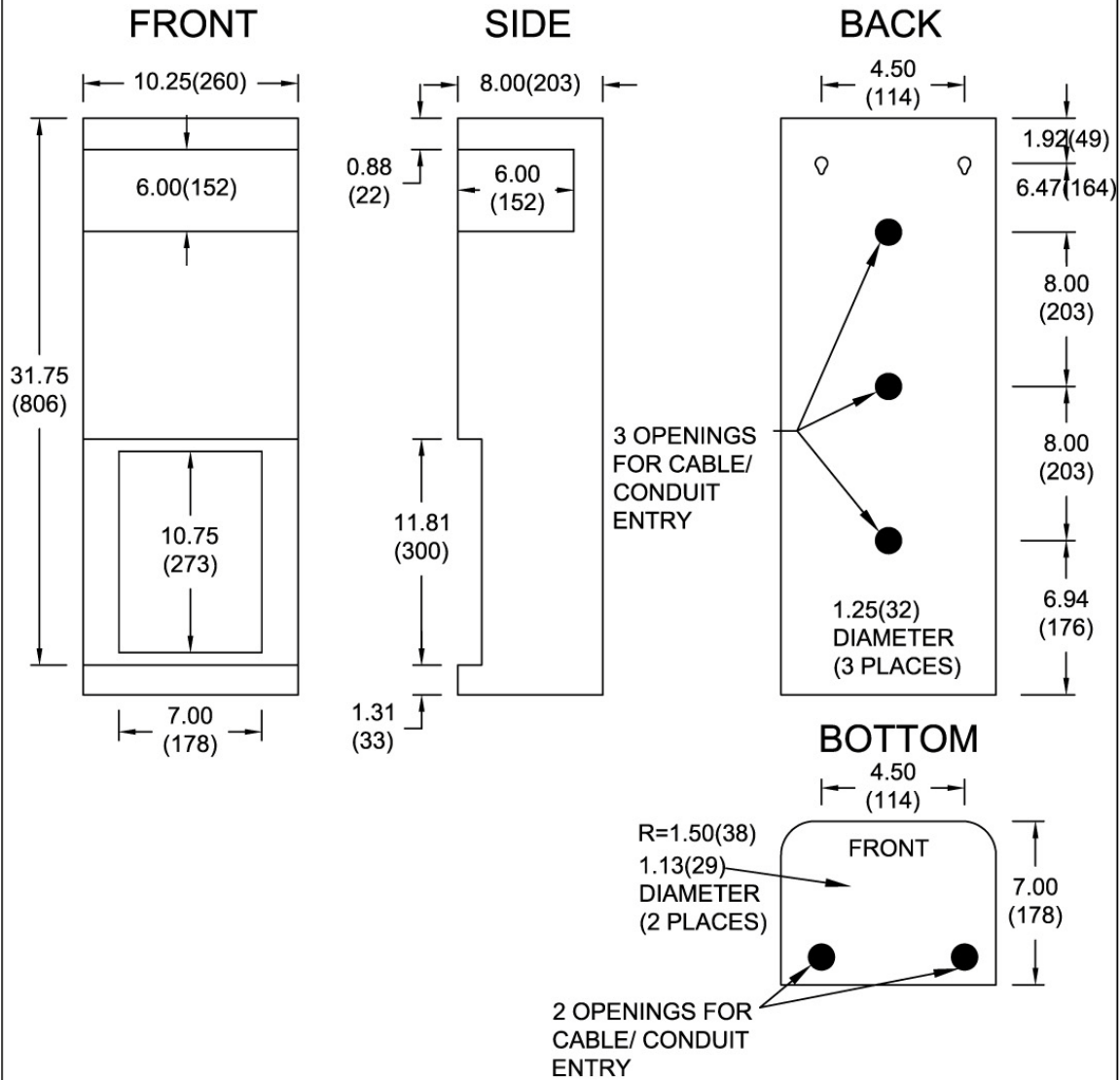

MEASUREMENTS ARE IN(MM),
TOLERANCE = ± 0.01 IN

UNIVERSITY OF ARIZONA		
MANUAL OF DESIGN SPECIFICATION STANDARDS		
STANDARD DETAIL:		
BLUE LIGHT PHONE WALL-MOUNT ENCLOSURE		
DRAWN BY: KML	DETAIL NO.	REVISIONS
APPROVED BY: FD&C	16705-D2	.
ACAD: 16705-D2		.

End of Section 16705

DIVISION 16 - ELECTRICAL

Section 16720 - Fire Alarm Systems

Introduction

The fire alarm systems here at the University are integrated together into a single reporting system which reports to the U of A police department. To maintain system integrity it has been decided that all systems shall be manufactured by Simplex and shall be compatible with the addressable multiplexed system as manufactured by Simplex. To maintain and insure system integrity with new projects, the University has developed a guide form specification, which must be edited by the engineer in charge of each particular project. Each fire alarm system specification must be evaluated on an item by item basis and the specification edited to be project specific. For example some projects by the nature of the type of building and its occupancy will be required to have a voice evacuation signal. For most projects the standard horns and strobes no longer will suffice. Smaller projects will not require the complexity of the design that the larger ones will require, and thus some of the specification may be deleted.

For new projects it will be necessary to connect the system back into the central reporting system loop. This loop is composed of a series of cables routed through the existing tunnel network. During the preliminary design it will be necessary for the engineer to discuss with the University Fire Safety representative as to the exact location of the point of connection to this loop.

For existing buildings the system interconnection should be intact, and it will be necessary only to tie the new system into the existing loop at the point of connection.

Where only a few devices are required it will be necessary for the engineer to delete all non-applicable portions of the guide form specification and make it project specific.

Typically the fire alarm systems are to be considered a higher quality system than what is normally used in a facility of this type. All new systems are to be fully addressable systems with horns and strobes throughout and in compliance with ADA and NFPA requirements. Smoke detectors are to be used in all corridors. Return air duct smoke detectors shall be provided for all AHU's over 2000 cfm per the International Mechanical Code. All conference rooms and classrooms are to have alarm indicators, with A/V's to be used in larger lecture halls. Strobes are to be used in all restrooms. Pull stations are to be used at all exits from a floor on multistory buildings and at any and all building exits. In addition provide pull stations where required by the NFPA 72. All mechanical rooms shall be protected using heat detectors. All electrical rooms, telecommunications rooms, storerooms, and janitor closets shall be protected using smoke detectors.

The requirement for message boards will be required in dormitories, large class rooms and lecture halls with an A3 Occupant load and where deemed required by the AHJ.

Elevators shall recall and monitoring shall comply with the latest AZ Elevator code.

Utilize Class A wiring to all devices on the system. Color codes shall be in accordance with University standards.

All conduits shall run concealed unless no other option is available. Conduit, wiring, j-boxes, etc. shall be installed in compliance with other areas of this standard. Conduits shall have a minimum separation of 6'. This is the University's decision and standards requirement.

All fire alarm systems designed and installed throughout the University shall be capable of being expanded easily and readily. In order to make this easier we would like to require that both alarm and mapnet loops have at least 30% spare capacity.

For all new projects it has been decided that the University will require the new system to be up and fully operational for a minimum of 5 days prior to having the University's State Fire Marshall do his final inspection. At the point in time that the contractor believes that the system is ready to begin the 5 day "burn in" the supplier will certify to the owner that the system is fully operational. Until receipt of this letter the acceptance test will not be considered to have begun. During the acceptance test no modifications to the system can be made. The

contractor may be permitted to remove or demolish the existing system where applicable and where permitted by the owner prior to acceptance of the new system by the owner.

Part 1 - General

- Provide in accordance with the standards set forth in the guide form specification and instructions from the UA Electrical Engineer during the pre-design conference.
- Design shall confirm to NFPA 72 "Performance Based Design, Partial Coverage", including special requirements of UA Fire Safety, Risk Management, the International Fire Code and the requirements of the University of Arizona, Department of Risk Management & Safety Office of the Fire Marshal.
- The consultant shall complete comprehensive plans, and single line diagrams based on the system described in the App-16720 Section of this DSS.
- The consultant shall perform voltage drop calculations as part of the Construction Document Submittal for looped signal circuiting. Signal circuits shall not exceed 70% loading in order to accommodate future system changes.
- Batteries shall support 24 hours of Standby Operation and 15 minutes of Alarm Operation.
- Provide heat detectors in elevator shafts, machine rooms. Set 20°F lower than sprinkler heads, to signal the FACP to shut down the elevators.
- The consultant shall show the following supervisory functions on plans and single line diagrams. All conductors shall be in metal conduit.
- Ethernet circuit from FACP, with jack, to network terminal board.
- Monitoring circuit from each elevator control monitoring circuit (in machine rooms) to the FACP.
- Monitoring circuit from Engine Generator to the FACP, to monitor generator running.
- The consultant shall provide emergency lighting in the vicinity of the FACP.
- Generally speaking, Graphic, LCD, or LED annunciation is not utilized.

Part 2 - Products

- Provide in accordance with the standards set for the in the guide form specification Section 16720, as discussed in the introduction to this section, and as directed.
- Where pull stations are susceptible to nuisance vandal pulling, a protective local alarm type covering device shall be provided.

Part 3 - Execution

- Provide in accordance with the standards set for the in the guide form specification Section 16720 and as discussed in the introduction to this section.
- Wiring color codes shall be as specified in division 16195. J-boxes shall be identified as per division 16195.
- Testing. Insert the following language at this Section:
 - "The fire alarm system shall be 100% complete, operational and free from trouble or alarm conditions prior to a 5 day burn in time, during which the system shall operate under normal conditions with no modifications by the contractor. Owner testing and acceptance shall be in conjunction with the Contractors final testing and verification. At the end of this period the fire alarm system shall be tested and

approved by the University's State Fire Marshal. Only upon receipt of approval by the University's State Fire Marshal shall this system be considered complete."

End of Section 16720

DIVISION 16 - ELECTRICAL

Section 16730 - Clock and Program Systems

Introduction

Clock systems shall be provided for all new buildings when specifically identified in the Project Scope of Work. The University has a master clock system which receives a signal from the National time standard located in Colorado. All campus clocks are synchronized to this signal from the master clock. Therefore it is imperative that the specification and drawings include requirements for connecting the new buildings to the plant distribution system.

Signal systems shall be provided for all new classroom type buildings and construction. The signal system shall be programmable through the building master clock system.

Bell system wiring shall be run with the clock system.

Each new or renovated system shall incorporate a building submaster clock to isolate each building in case of a fault on the main campus master clock.

Part 1 - General

- Provide complete submittals on all new clock systems including complete maintenance and operation manuals for each new system installed.

Part 2 - Products

- Compatible with the present Master time system which is manufactured by Simplex Time Recorder Company.
- Any substitute must prove that it is compatible with this system.
- The existing system is a 24 vdc impulse system with a 24 vdc 3 wire correction. All clocks should be semiflush mounted. Each clock shall have an integral two lobe 5 minute catch up cam.
- Wiring color code should be in accordance with section 16195.

Part 3 - Execution

- For rearrangement type projects final tie-in of clocks to building system will be by the University Facilities Management Electric Shop.
- Final tie in of new building systems with the campus systems will be by the University Facilities Management Electric Shop.
- Testing for new facilities shall be done with factory trained representative of the manufacturer, the U of A electric shop, and the Engineer.

End of Section 16730

DIVISION 16 - ELECTRICAL

Section 16950 - Testing

Introduction

Testing for all areas shall be listed under this section and referenced back to the appropriate Section.

Testing shall be done in accordance with NETA standards.

Part 1 - General

- Written documentation shall be provided to the UA electrical engineer for all testing accomplished under this section.
- Although NETA test standards are referenced herein for brevity it is required that the engineering firm, rewrite the test standards for application to the specific project.
- All the required testing shall be fully spelled out in the specifications.
- Cable shall be tested on their respective reels.
- Cable shall be VLF tested with terminations in place after assembly.

Part 2 - Products

- A partial list of equipment to be tested shall include:
 - Feeders and cables
 - high voltage switchgear
 - transformers
 - panelboards
 - switchboards
 - emergency generator
 - ups type systems.
 - 50 Hp and larger motors - absorption - polarization index
- Testing of medium voltage cables (5KV or 15KV), transformers, and switchgear shall be by a third party testing firm which has all of the equipment and capabilities for performing the specified tests.
- All other testing shall be accomplished by the electrical contractor doing the work.

Part 3 - Execution

- All medium voltage rated cable shall be tested in accordance with NETA testing standards.
- Medium voltage transformers, cable, and switchgear shall be tested in accordance with NETA testing standards, with a complete written report provided to the U of A prior to completion of the project. All testing of this equipment shall be accomplished in the presence of the Engineer or a representative of the University Facilities Management Electric Shop.
- For actual requirements of each area, verify testing requirements with the Engineer.
- All wire and cable utilized on the 120/208 and 480/277 volt systems shall be tested.
- Ground resistance testing shall utilize the fall of potential method of testing.

- All panelboards and switchboards shall be meggar tested prior to energizing.
- All connections inside of switchboards, panelboards, motor control centers, and similar equipment shall be torqued and tested prior to energizing the equipment.

End of Section 16950

GENERAL INFORMATION

Project No.: _____

Project Name: _____

Consultant: _____

CM@Risk: (If applicable) _____

Construction Period: _____ Days

Liquidated Damages: \$ _____ / Calendar Day; \$ _____ / Calendar Day

Optional Prices:	<u>Yes</u>	<u>How Many?</u>	Set Up Item 2 in Bid Form Part 1 (If Design-Bid-Build), coordinate Optional Price wording for Section 01019 or 01030 (whichever section is used for Optional Prices)
	<u>No</u>		Delete from Bid Form Part 1 (If Design-Bid-Build), edit Div 1 section accordingly

Construction Estimate Range: _____

The following information in blue is for Bid Projects. Proceed to Boilerplate Index for CM@Risk projects.

Documents Deposit: \$ _____ / Each for _____ Sets (2 is standard)

Pre-Bid Location: _____

SCHEDULING A BID OPENING DATE AND TIME, AND COMPLETING THE BOILERPLATE/ADVERTISING PROCESS

Upon completion of a boilerplate and before faxing for publication, obtain anticipated Advertising, Pre-Bid Meeting, and Bid Opening Dates from the Project Manager.

- Bid Openings are usually held on Tuesdays or Thursdays; usually at 2:00 p.m. or 4:00 p.m.
- Confirm the availability of the anticipated Bid Date through the Master Bid Schedule
- If the anticipated date is available, make sure all the other dates do not conflict:
 - Second date of publication is one week after first date
 - Pre-bid is about one and a half weeks after first date of publication
 - Bid Date is **at least** three weeks after first date of publication

Scheduling the Bid Opening:

- Go into Meeting Maker and Propose Meeting
- Invite Guests: Construction Group Manager, Facilities Project Manager (construction), Project Manager (Design) and the selected room. cc your backup Support Staff
- Go to Master Bid Schedule and Create New Activity for the Pre-Bid and Bid Dates

If this is a capital project and a large number of bidders are expected, you may need to reserve 104/106

Note the confirmed bidding process dates:

_____ Date of Documents (first ad
date)

&

Ad Dates

Pre-bid Date and Time

Bid Due Date and Time

Complete the Boilerplate by inserting the various dates above in the appropriate locations.

Fax following information:

For Small and Medium Projects:

Fax Cover Sheet, Advertisement ("Notice to Contractors of Intent to Receive Bids") and Letter to Daily Territorial

Fax Cover Sheet and Advertisement to APTAN, and Dodge Plan Service Information **MUST** be received at Newspaper by: 10:00 a.m. two days prior to printing

For Large (Capital) Projects:

Advertisement and Letter to Daily Territorial

Advertisement and Letter to Tribune Newspapers

Advertisement to Construction Market Data (CMD)

Information **MUST** be received at Newspapers by: 10:00 a.m. three days prior to printing, taking into account holidays

DOUBLE CHECK DEADLINES WITH NEWSPAPERS WHEN ANY HOLIDAY IS APPROACHING

Distribute copies of Advertisement and letters as follows

Business Services (advertisement and letter(s))

Project Manager (advertisement only)

Director, Facilities Design & Construction (advertisement only)

Associate Director (advertisement only)

Construction Group Manager (advertisement only)

Design Group Manager (advertisement only)

Engineering Group Manager (advertisement only)

Contracts Administrator, Facilities Design & Construction (advertisement only)

Contracts Administrator, Procurement & Contracting (advertisement only)

Administrative Secretaries, Design & Engineering (fax cover letters, letter(s), and advertisement)

Public Information Coordinator (advertisement only)

Receptionist (advertisement only)

BOILERPLATE INDEX

Use the following four Division 00 Sections for CM@Risk Projects

DIVISION 00 – CM@RISK REQUIREMENTS:

00100	Instructions to CM@RISK	
00102	Prior Approval Request Form	
00200	Information Available to Bidders	<i>Edit title to delete "to Bidders" when using CM@Risk</i>
00800	Supplementary Conditions	<i>Use only if there is any specific contract provisions such as grant language or other Federal requirements that must be passed through into the Construction Contract and have not already been incorporated into the CM@Risk Agreement</i>
00860	Schedule of Drawings	<i>Info to be provided by design consultant</i>

Use the following Division 00, Sections 00030-00900 as required for Design-Bid-Build Projects.

DIVISION 00 – BIDDING REQUIREMENTS:

00030	Notice to Contractors of Intent to Receive Bids
00100	Instructions to Bidders
00101	Inquiries
00102	Prior Approval Request Form
00200	Information Available to Bidders
00300	Bid Form - Stipulated Sum
00400	Supplements to Bid Form
00401	Appendix A - List of Subcontractors/Material Suppliers
00402	Appendix B - List of Unit Prices
00403	Appendix C - List of Optional Prices
00404	Appendix D - List of Separate Prices
00405	Appendix E - Cost Breakdown
00406	Appendix F - List of Supplementary Architectural Information
00407	Appendix G - List of Supplementary Mechanical Information
00408	Appendix H - List of Equipment
00410	Bid Bond
00490	Qualification of Corporation Signature
00491	Qualification of Limited Liability Company Signature

CONTRACT FORMS

00610	Performance Bond	
00620	Payment Bond	
00630	Performance Bond for Subcontracts UA Agreement Between Owner and Contractor (2000) UA Agreement Between Owner and Contractor (CM Edition, 2000)	<i>Determine applicable contract and retrieve latest version from shared library</i>
00800	Supplementary Conditions	
00860	Schedule of Drawings	
00900	Addendum	

Edit the following Division 01 specification list to be project specific. Reference to actual sections may be required to make final selection.

DIVISION 01 – GENERAL REQUIREMENTS

Section	Section Title	Selection Information
01010	SUMMARY OF WORK	
01019	CONTRACT CONSIDERATIONS	<i>For smaller projects, use this section. Larger projects can use expanded sections 01027, 01028 & 01030 in lieu of this section. Note that this section also includes allowances. If there are allowances, this section should be retained even if expanded sections are used as noted above. Edit remainder of section accordingly.</i>
01027	APPLICATIONS FOR PAYMENT	<i>Expanded section in lieu of APPLICATIONS FOR PAYMENT article in Section 01019</i>
01028	MODIFICATION REQUIREMENTS	<i>Expanded section in lieu of CHANGE PROCEDURES article in Section 01019</i>
01030	OPTIONAL PRICES	<i>Expanded section in lieu of OPTIONAL PRICES article in Section 01019</i>
01039	COORDINATION AND MEETINGS	
01043	PARTNERING	
01045	CUTTING AND PATCHING	<i>Use for minor alteration work, Where more significant Alterations are required, consider Section 01120</i>
01050	FIELD ENGINEERING	<i>Expanded section in lieu of FIELD ENGINEERING article in Section 01039</i>
01090	REFERENCE STANDARDS	<i>Expanded section in lieu of REFERENCES article in Section 01400</i>
01120	ALTERATION PROJECT PROCEDURES	<i>In lieu of Section 01045 CUTTING and PATCHING when alteration work is more extensive</i>
01300	SUBMITTALS	
01310	CONSTRUCTION PROGRESS SCHEDULES	<i>Expanded section in lieu of CONSTRUCTION PROGRESS SCHEDULE article in Section 01300</i>
01311	COST-LOADED CONSTRUCTION PROGRESS SCHEDULES	<i>Expanded section in lieu of CONSTRUCTION PROGRESS SCHEDULE article in Section 01300 or in lieu of Section 01310. Note: using a cost loaded schedule has cost implications. For CM@Risk projects this requirement must be identified early in the design process.</i>
01400	QUALITY CONTROL	<i>Use Testing and Inspection services in this Section Typically. For expanded sections on Testing and Inspection services see 01410</i>

01500 CONSTRUCTION FACILITIES AND TEMPORARY CONTROLS	<p><i>and 01411</i></p> <p><i>Use this section for small projects and/or projects with little site work. For large projects and projects with extensive site construction use expanded sections 01510, 01550, 01555, 01560, 01561, 01570 and 01590 in lieu of 01500. These sections address dust control, traffic control, haul routes etc. in a more thorough and detailed way that is required especially when projects are adjacent to the planning boundaries or when surrounding UA facilities will be impacted by construction.</i></p>
01510 TEMPORARY UTILITIES	<i>Expanded section in lieu of Section 01500</i>
01540 SECURITY	<i>When extraordinary security is required use this expanded section</i>
01550 ACCESS ROADS AND PARKING AREAS	<i>Expanded section in lieu of Section 01500</i>
01555 CONSTRUCTION FACILITIES	<i>Expanded section in lieu of Section 01500</i>
01560 TEMPORARY CONTROLS	<i>Expanded section in lieu of Section 01500</i>
01561 CONSTRUCTION CLEANING	<i>Expanded section in lieu of Section 01500</i>
01570 TRAFFIC REGULATION	<i>Expanded section in lieu of Section 01500</i>
01580 PROJECT IDENTIFICATION AND SIGNS	
01590 FIELD OFFICES AND SHEDS	<i>Expanded section in lieu of Section 01500</i>
01600 MATERIAL AND EQUIPMENT	
01601 SUBSTITUTION REQUEST FORM	
01650 STARTING OF SYSTEMS	
01700 CONTRACT CLOSEOUT	
01730 OPERATION AND MAINTENANCE DATA	<i>Expanded section in lieu of OPERATIONS AND MAINTENANCE DATA article in Section 01700</i>
01740 WARRANTIES	<i>Expanded section in lieu of WARRANTIES article in Section 01700</i>
01741 WARRANTY FORM	<i>Use this form in addition to either 01730 or 01740</i>
01810 GENERAL COMMISSIONING REQUIREMENTS	<i>Assume all large capital projects include Commissioning as part of the scope. Independent Commissioning is also part of LEED certification. This section outlines GC, Subcontractor requirements as it relates to the Commissioning scope.</i>



Project Manual and Specifications for

*******PROJECT NAME*******

*****Date*****

UA Project No.: **-****

For:

The Arizona Board of Regents

Project Management:
Department Of Facilities Design And Construction
220 West Sixth Street, University Services Annex
P.O. Box 210300, Tucson, Arizona 85721-0300

Prepared by:

****Consultant Name****

****Address****

****City, State, Zip****

****Phone Number****

NOT FOR CONSTRUCTION

TABLE OF CONTENTS

Project Number:

Project Name:

NO. OF PAGES

DIVISION 0 – CM@RISK REQUIREMENTS:

00100	Instructions to CM@RISK	5
00102	Prior Approval Request Form.....	4
00200	Information Available to Bidders.....	2
00860	Schedule of Drawings	1

DIVISION 0 – BIDDING REQUIREMENTS:

00030	Notice to Contractors of Intent to Receive Bids.....	3
00100	Instructions to Bidders.....	15
00101	Inquiries.....	1
00102	Prior Approval Request Form.....	4
00200	Information Available to Bidders.....	2
00300	Bid Form - Stipulated Sum	5
00400	Supplements to Bid Form.....	3
00401	Appendix A - List of Subcontractors/Material Suppliers	1
00402	Appendix B - List of Unit Prices.....	1
00403	Appendix C - List of Optional Prices.....	1
00404	Appendix D - List of Separate Prices	1
00405	Appendix E - Cost Breakdown	1
00406	Appendix F - List of Supplementary Architectural Information	1
00407	Appendix G - List of Supplementary Mechanical Information	1
00408	Appendix H - List of Equipment.....	1
00410	Bid Bond.....	1
00490	Qualification of Corporation Signature	1
00491	Qualification of Limited Liability Company Signature	1

CONTRACT FORMS

00610	Performance Bond	1
00620	Payment Bond.....	1
00630	Performance Bond for Subcontracts	1
	UA Agreement Between Owner and Contractor (August 1999).....	39
	UA Agreement Between Owner and Contractor (CM Edition, August 1999)	42
00800	Supplementary Conditions	1
00860	Schedule of Drawings	1
00900	Addendum.....	4

DIVISION 01 – GENERAL REQUIREMENTS

01010	SUMMARY OF WORK.....	8
01019	CONTRACT CONSIDERATIONS.....	10
01027	APPLICATIONS FOR PAYMENT	6
01028	MODIFICATION REQUIREMENTS	5
01030	OPTIONAL PRICES.....	3

May 2007

TABLE OF CONTENTS

Project Number:

Project Name:

NO. OF PAGES

01039	COORDINATION AND MEETINGS	6
01043	PARTNERING.....	2
01045	CUTTING AND PATCHING	7
01050	FIELD ENGINEERING	4
01090	REFERENCE STANDARDS	5
01120	ALTERATION PROJECT PROCEDURES.....	5
01300	SUBMITTALS.....	4
01310	CONSTRUCTION PROGRESS SCHEDULES	11
01311	COST-LOADED CONSTRUCTION PROGRESS SCHEDULES	14
01400	QUALITY CONTROL	6
01500	CONSTRUCTION FACILITIES AND TEMPORARY CONTROLS	11
01510	TEMPORARY UTILITIES.....	6
01540	SECURITY	3
01550	ACCESS ROADS AND PARKING AREAS.....	4
01555	CONSTRUCTION FACILITIES	4
01560	TEMPORARY CONTROLS.....	5
01561	CONSTRUCTION CLEANING	3
01570	TRAFFIC REGULATION.....	3
01580	PROJECT IDENTIFICATION AND SIGNS	4
01590	FIELD OFFICES AND SHEDS.....	5
01600	MATERIAL AND EQUIPMENT	6
01601	SUBSTITUTION REQUEST FORM	3
01650	STARTING OF SYSTEMS	5
01700	CONTRACT CLOSEOUT.....	11
01730	OPERATION AND MAINTENANCE DATA.....	6
01740	WARRANTIES	3
01741	WARRANTY FORM	1
01810	GENERAL COMMISSIONING REQUIREMENTS	19

May 2007

DIVISION 00

UA No.

Section 00030

NOTICE TO CONTRACTORS

ARIZONA BOARD OF REGENTS

NOTICE TO CONTRACTORS OF INTENT TO RECEIVE BIDS

Sealed bids will be received until [__p.m., __, __,] 20[___] , by the Arizona Board of Regents, care of the Department of Facilities Design and Construction, University Service Annex, Room __, University of Arizona in Tucson, Attention: Mr. Robert R. Smith, for the furnishing of all labor, materials, transportation and services required for Project No.: [____]; [_____] on the campus of the University of Arizona in accordance with the plans and specifications on file in the office of [____], Tucson, Arizona 857 [___]. The project consists of **[insert example]**

Bids will be opened publicly in Room [___] of the University Service Annex, 220 West Sixth Street, on [___], [___], 20[___] at [___] and read aloud. Plans and specifications for the proposed work may be obtained at **[Reproductions, Inc., 234, East Sixth Street, Tucson, Arizona 85705], Phone [622-7747]**, by making a deposit of **[\$50.00]** per set in the form of check or money order, made payable to the University of Arizona. Bidders may obtain **[2]** sets on deposit, which will be refunded upon the return of the plans and specifications in **good condition**. Bidders desiring to obtain additional sets may do so by a direct, non-refundable purchase. Plans and specifications **shall be returned to [Reproductions, Inc] within ten (10) calendar days after the bid date** to be eligible for refund.

All Potential Bidders are strongly urged to attend the Pre-Bid Conference and Site Visit. The Conference will be held on [__day__], [__date__], at [__time__]. Bidders shall assemble at **[location]**.

All Potential Bidders are cautioned that attendance at the Pre-Bid Conference and Site Visit is mandatory for general contract bidders and for **[subcontractors]** subcontract bidders. Each attending firm must be represented by its actual proposed project manager, superintendent, and/or foreman to qualify as having attended the Meeting. The Meeting will be held on [__day__], [__date__], at [__time__]. Bidders shall assemble at **[location]**. (refer to the map in the drawings).

A certified or cashier's check or a surety bond for ten percent (10%) of the total amount of the Bid (base plus all additive optional prices) and applicable local transaction privilege or use taxes or both must accompany each Bid, as a guarantee that the Contractor will enter into a contract to perform the Bid in accordance with the plans and specifications or as liquidated damages in the event of failure or refusal of the Contractor to enter into the contract, which check or bond will be returned to the unsuccessful bidders, and to the successful bidder upon the execution of a satisfactory bond and contract, as prescribed by Arizona Revised Statutes.

Issued October 2003

00030-1

DIVISION 00

UA No.

Section 00030

NOTICE TO CONTRACTORS

The apparent low bidder, after receiving a Notice of Intent to Award, shall furnish to the aforesaid Board of Regents satisfactory performance and payment bonds, each in an amount equal to one hundred percent (100%) of the full amount of the Bid. These bonds are not to be expressly limited as to time in which action may be instituted against the surety company for possible non-performance of the Contractor.

Work shall commence in accordance with a Notice to Proceed issued after execution of the contract and shall be completed **[within [] [] days from the starting thereof.] [by _____.]**

The Board reserves the right to reject any or all bids, to waive or decline to waive irregularities in any bid, or to withhold the award for any reason it may determine and also reserves the right to hold any or all bids for a period of **[sixty (60) days]** after the date of the opening thereof. No bidder may withdraw his bid during this **[sixty (60)]** day period.

All correspondence relating to this project should be addressed to:

ARIZONA BOARD OF REGENTS

[name**]**
Project Coordinator
Department of Facilities
Design and Construction
University of Arizona
P.O. Box 210300
Tucson, Arizona 85721-0300

By: Robert R. Smith
Director
Department of Facilities
Design and Construction

PUBLISH: **Daily Territorial:** _____, and _____, 20____

[Mesa Tribune _____: _____ and _____, 20 ____]

[Scottsdale Progress _____: _____ and _____, 20 ____]

[Construction Market Data : _____ and _____, 20 ____]

Issued October 2003

1 SUMMARY

1.1 DOCUMENT INCLUDES

A. Invitation

1. Bid Submission.
2. Work Identified in the Contract Documents.
3. Contract Time.

B. Bid Documents and Contract Documents.

1. Definitions.
2. Contract Documents Identification.
3. Availability.
4. Examination.
5. Inquires/Addenda.
6. "Or Equal" Products.

C. Site Assessment.

1. Site Examination.
2. Prebid Conference.

D. Qualifications.

1. Evidence of Qualifications and Responsibility.
2. Subcontractors.

E. Bid Submission.

1. Bidder Interest in More Than One (1) Bid.
2. Submission Procedure.
3. Bid Acceptability.

F. Bid Enclosures/Requirements.

Section 00100

INSTRUCTION TO BIDDERS

1. Security Deposit.
 2. Qualification of Corporate Signature.
 3. Qualification of Limited Liability Company Signature.
 4. Performance Assurance.
 5. Insurance.
 6. Bid For Requirements.
 7. Fees for Changes in the Work.
 8. Bid Form Signature.
 9. Additional Bid Information.
- G. Selection and Award.
1. Contract.
 2. Optional Prices.
 3. Unit Prices.
- H. Bid Acceptance/Rejection.
1. Duration of Bid.
 2. Acceptance of Bid.
- I. Owner Policies/Regulations.
1. Approved Applicator letter.
 2. Policy on Sexual Harassment.
 3. Drugs, Alcohol and Firearms.
 4. Recycling and Reuse of Salvaged/Surplus and Waste Materials.
 5. Payment to Subcontractors.

1.2 RELATED DOCUMENTS

- A. Document 00030 – Notice to Contractors of Intent to Receive Bids.

Section 00100

INSTRUCTION TO BIDDERS

- B. Document 00200 – Information Available to Bidders.
- C. Document 00300 Bid Form– Stipulated Price.
- D. Document 00400 – Supplements to Bid Form.
- E. Document 004100 – Bid Bond.
- F. Document 00490 – Qualification of Corporation Signature.
- G. Document 00491 – Qualification of Limited Liability Company Signature.
- H. **Document 00800 – Supplementary Conditions**

2 INVITATION.

2.1 BID SUBMISSION

- A. Properly executed Bids, signed, dated and under seal, when applicable, will be received by the Owner as stated in the Notice to Contactors of Intent to Receive Bids.
- B. Bids submitted after the stated time will be returned to the bidder unopened.
- C. Submit all of Document 00400 – Supplements to Bid Form with the Bid except as directed by Subsection 7.9 of these Instructions to Bidders.
- D. Bids will be opened publicly at the time and location stated in the Notice to Contractors of Intent to Receive Bids.
- E. Any Bidder may withdraw his bid, either personally or by written request, at any time prior to the scheduled closing time for receipt of bids. No Bid may be withdrawn after the scheduled closing time for receipt of bids.

2.2 WORK IDENTIFIED IN THE CONTRACT DOCUMENTS

- A. Work of this proposed Contract comprises **[general construction], [site development], [remodeling], [renovation], [demolition], [_____] [including structural], [mechanical], [electrical], [_____] Work]**.
- B. This Project is located on the campus of the University of Arizona, Tucson, Arizona.
- C. Work required by any one of the Contract Documents shall be binding as if required by all. The intention of the Documents is to include all labor, equipment, material or other items inferable from the documents as being necessary to produce the intended results.

2.3 CONTRACT TIME

Section 00100

INSTRUCTION TO BIDDERS

- A. Perform the Work within the time stated in the Bid Form. The Bidder, by submitting a Bid, accepts the Contract Time period stated for performing the Work. The completion date in the Agreement shall be the Contract Time added to the commencement date set forth in the Notice to Proceed.
- B. By submitting a Bid, every Bidder represents that the Bid is based upon the completion time specified in the Bidding Documents, and acknowledges that Owner shall not be liable in any way for damages, claims or suits arising from Bidder's intended completion of the Project prior to the contractual completion date.

3 BID DOCUMENTS AND CONTRACT DOCUMENTS

3.1 DEFINITIONS

- A. Bid Documents: Consist of the Contract Documents including Instructions to Bidders, Information Available to Bidders, Bid Form and Appendix A, other Supplements to Bid Forms and Appendices as applicable, Bid securities, and all items listed in the Table of Contents of the Project Manual.
- B. Contract Documents: The Construction Agreement Between Owner and Contractor with General Conditions of the Construction Agreement **[(Construction Manager Edition)]**, including issued Addenda.
- C. Bid or Bidding: Act of submitting a Bid.
- D. Bid Price: Monetary sum identified by the Bidder in the Bid Form.

3.2 CONTRACT DOCUMENTS IDENTIFICATION

- A. The Contract Documents are dated (_____) and identified as Project number (_____) **(insert project name)**, as prepared by **[the Architect/Engineer]** under the direction of the President of the University of Arizona for the Arizona Board of Regents.

3.3 AVAILABILITY

- A. Bid Documents may be obtained as stated in the Notice to Contractors of Intent to Receive Bids.
- B. Deposit will be refunded if Bid Documents are returned complete, undamaged, unmarked and reusable, within the time period stated in the Notice. Failure to comply will result in forfeiture of deposit.
- C. Bid Documents are made available only for the purpose of obtaining Bids for this Project. Their use does not grant a license for other purposes.

3.4 EXAMINATION

Section 00100

INSTRUCTION TO BIDDERS

- A. Bid Documents are on display at Shirley's Plan Services, FW Dodge, and Reed Construction Data.
- B. Upon receipt of Bid Documents, verify that documents are complete. Notify Architect/Engineer should the documents be incomplete.
- C. Immediately notify the Architect/Engineer upon finding discrepancies or omissions in the Bid Documents.

3.5 INQUIRIES/ADDENDA

- A. Should a Bidder find discrepancies in, or omissions from the drawings, specifications or other bidding documents, or should he be in doubt as to their meaning, he should at once notify in writing, using the Form included at the end of these Instructions, **[(Person and Firm names)] telephone [_____]**, who will send a written instruction, correction or interpretation to each person receiving a set of such documents in the form of an Addendum. The Owner will not be responsible for any explanations or interpretations except those duly issued in the form of written Addenda. Addenda so issued during the time of bidding shall be acknowledged on the bid form and will be made part of the contract documents, and all resultant costs shall be included in the Bid Price. Such Addenda shall be binding on all Bidders, and it shall be the responsibility of all Bidders to ascertain the existence of Addenda and the content of each and to acknowledge same on the Bid Form.
- B. Clarifications requested by Bidders must be in writing, using the Form included at the end of these Instructions, not less than **[7]** days before date set for receipt of Bids, to enable reply in the form of an Addendum.
- C. Should any Bidder have questions after complying with the above instruction, he shall notify **[(FDC contact)]** not later than five (5) days prior to the bidding date by calling the following" **() ()**.

3.6 "OR EQUAL" PRODUCTS

- A. Each Bidder represents that his Bid is based upon the materials and equipment described in the Bid Documents.
- B. Any Pre-bid requests for substitution of products shall follow the procedure specified herein.
- C. No "or equal" products will be allowed unless written approval has been obtained for the proposed "or equal" material or equipment prior to the opening of Bids. Such prior approval shall be by the Architect, in writing, in the form of an Addendum to the Bid Documents.
- D. In order for prior approval to be given, a written request for approval of such products shall be submitted at least **[fourteen (14) calendar days]** prior to bidding, using the Form included at the end of these Instructions, and the material submitted shall

Section 00100

INSTRUCTION TO BIDDERS

- include a complete description, drawings, specifications, cut sheets, performance and test data and any other information necessary for a complete evaluation.
- E. Wherever the words "or equal" occur in the Bid Documents, such wording shall be construed to mean "or equal product as approved by the Architect/Engineer prior to submission of Bids."
 - F. For information regarding substitution of material or equipment after Bids have been opened, see Subsection 1.7 of Section 01600 of the Specifications.
 - G. For information regarding substitution of subcontractors see Section 5.2, Subcontractors, of these Instructions to Bidders.

4 SITE ASSESSMENT

4.1 SITE EXAMINATION

- A. Before bidding, Bidder shall examine the site and fully determine the conditions under which he will operate in performing the work under this contract. No allowance will be made subsequently for his failure to do so. He shall satisfy himself as to the nature and location of the work and the general and local conditions. He shall gain full knowledge as to transportation, disposal, handling and storage of materials, availability of water, electric power, and all other facilities in the area which will have a bearing on the performance of his work and the contract for which he submits his bid.
- B. Any failure by the Bidder to acquaint himself with all the available information shall not relieve him from any responsibility for performing his work properly. No additional compensation shall be allowed for conditions reasonably ascertainable by Bidder prior to submission of his Bid.
- C. Bidders are cautioned that certain work hour restrictions (Owner, City of Tucson, or both) may apply to this project, and that all such applicable restrictions will be strictly enforced. Refer to Section 01010 for details of Owner regulations.
- D. A visit to the project site has been arranged for bidders as part of the Prebid Conference.

4.2 PREBID CONFERENCE

- A. A bidders conference has been scheduled as stated in the Notice to Contractors of Intent to Receive Bids. All general contract **[and [major] subcontract]** Bidders **[and suppliers]** are invited.

*****[OR]*****

Due to the nature of this Project, the Owner is requiring all interested Bidders attend the Prebid Conference and site visit. This requirement applies to all general contract bidders, and to the following subcontractors.

[list subcontractor discipline]

General contract bids will be accepted from attendees only, and non-attending subcontractors in the above disciplines will be deemed unacceptable.

The Owner will make every reasonable effort to schedule the Prebid Conference for the convenience of all interested bidders.

- B. Representatives of the **[Owner] [Architect/Engineer] [_____]** will be in attendance.
- C. Summarized minutes of this meeting will be circulated to **[attendees] [all plan holders of record] [_____]**. These minutes **[will not] [will]** form part of the Contract Documents.
- D. Information relevant to the Bid Documents will be recorded in an Addendum.

5 QUALIFICATIONS

5.1 EVIDENCE OF QUALIFICATIONS AND RESPONSIBILITY

- A. Upon request of the Owner, a Bidder whose bid is under consideration for the award of the Contract shall submit promptly to the Owner satisfactory evidence showing the Bidder's financial resources, his construction experience, organization, and resources available for the performance of the Contract.

5.2 SUBCONTRACTORS

- A. The Owner reserves the right to reject a proposed Subcontractor for reasonable cause.
- B. Refer to Section 13 of the General Conditions.
- C. The University of Arizona believes that seeking or encouraging post-bid or post-award price competition among subcontractors ("bid shopping") by an apparent low or successful general contract bidder has a detrimental effect upon quality and delivery of the completed project, and is not in the best interests of the University. Therefore the University will not approve substitution of a subcontractor on the basis of lower price. The conditions under which the University will consider a request for substitution of a subcontractor are:
 - 1. The request for substitution is a result of changes in scope, materials or equipment made by Owner during post-bid cost reduction negotiations as allowed by Subsection 3-803.B.7 of the University Procurement Code.
 - 2. Owner actions, such as the selection of Optional Price(s) or optional work, makes a subcontractor's bid non-responsive or significantly non-competitive.

Section 00100

INSTRUCTION TO BIDDERS

3. Written admission by the subcontractor of its inability to perform the work included in its bid or subcontractor as required by the Contract Document.
 4. A written refusal by the subcontractor to enter into a subcontractor for the price and scope of work included in its bid on bid day, utilizing the standard subcontract form required by Subsection 5.2.E below.
 5. Insolvency or bankruptcy, cessation of business operations, or other inability of the subcontractor to perform the work bid or contracted for.
 6. Persistent or repeated failure or refusal by the subcontractor to perform its work as reasonably expected by the General Contractor to enable the General Contractor to meet its contractual commitment to the University.
 7. No license or improper license for the work included in the bid or subcontract.
- D. When the Bidder proposes to perform certain items of work with its own forces and so indicates on the List of Subcontractors (Appendix A), the Bidder shall, as Contractor, perform the work so designated unless the Owner has a reasonable objection to such arrangement prior to the award of the Contract.
- E. The University of Arizona believes there is a need for uniformity of contract documents at all tiers of the construction contracting process. Therefore, the University requires that all subcontractors on University projects be executed using AIA Form A401-1997. This form shall be fully conformed to be provisions of the Prime Contract, including, but not limited to, the following changes:
1. Delete Paragraph 1.2 in its entirety.
 2. Delete from the first sentence of Paragraph 2.1 the words "the provisions of the edition of AIA Document A201 current as of the date of this Agreement apply to this Agreement pursuant to Paragraph 1.2 and".
 3. Delete Paragraph 3.2.5 in its entirety.
 4. Add Paragraph 6.3 as follows:

"This Article 6 shall not be deemed a limitation of rights or remedies which the Subcontractor may have under Federal law or under applicable labor or material payment bonds unless such rights or remedies are expressly waived by the Subcontractor."
 5. Delete the wording "along with reasonable overhead and profit on the Work not executed" at the end of Paragraph 7.2.4.
 6. Delete Paragraphs 13.7.2, 13.7.3, and 13.8 in their entirety.

As evidence of compliance with this Subsection 5.2.E, the Contractor shall furnish to the Owner, within the time limits stated in Section 01300 of the Project Manual, one fully executed copy of all subcontracts for this project. Each copy shall consist of the

Section 00100

INSTRUCTION TO BIDDERS

subcontract agreement (Form A401), with compensation amounts deleted but including all special or supplementary conditions applicable to the subcontract.

- F. The University of Arizona is subject to and complies with the prompt pay provisions contained in the University Procurement Code under Subsection H of Section 3-804. Bidder's attention is directed to the payment provisions of the subcontract agreement (AIA Form A401-1997) specified under Subsection 5.2.E above for use on all University projects. The provisions of Form A401 regarding payment to subcontractors are in general more stringent than are the provisions contained in the University Procurement Code.

The University of Arizona believes prompt payment at all levels of the construction process is vital to a successful project for all the parties involved. Therefore, the University welcomes inquiries or notices regarding slow payment or nonpayment from any party with appropriate standing. In no event will the University continue to make progress payments when there is or appears to be a violation of Subsection 3-804.H of the University Procurement Code which requires payment to subcontractors by the General Contractor within seven (7) days of receipt of the Owner's payment.

- G. In accordance with Section 13.5 of the General Conditions, the Owner requires from each subcontractor whose subcontract amount is \$100,000 or more a Performance Bond obtained by the subcontractor as a separate entity. These subcontractor bonds shall be written using the form (Arizona Board of Regents—Performance Bond for Subcontractors) bound in the Project Manual, copies of which are available from the Owner. Subcontractor bonds shall accompany the subcontracts when submitted in accordance with Subsection 5.2.E above. If approved in advance by the Owner, the Contractor may provide subcontractor default protection that is equivalent or better than bonds provided by the subcontractors. The cost of such bonds or default protection shall be included in the Bid.

Upon request by the Owner, a Bidder whose bid is under consideration for the award of the Contract shall submit promptly to the Owner a proof of ability to obtain a performance bond as a separate entity for each subcontract bidder subject to the provisions of this Subsection 5.2.G. The proof of ability shall be on the original letterhead of the subcontractor's bonding agent, be signed by the individual within the agency authorized to sign such a certification, and embody the following wording:

"I certify that this agency regularly issues Performance Bonds on behalf of (insert name of subcontractor) with (list name of Surety) as Surety, and that this agency will issue a Performance Bond with that Surety for the work proposed to be performed by (insert name of subcontractor) on University of Arizona Project No. (insert University project number). The Bond will be executed on the prescribed form as bound in the Project Manual for the Project upon award of the subcontract, and the penal sum will equal the full amount of the subcontract."

Failure to submit the required proof for any subcontract bidder subject to the provisions of this Subsection 5.2.G will render the subcontract bidder unacceptable to the Owner.

Section 00100**INSTRUCTION TO BIDDERS****6 BID SUBMISSION****6.1 BIDDER INTEREST IN MORE THAN ONE BID**

- A. No person, firm, or corporation shall be allowed to make or file more than one (1) bid for the same work. A person, firm, or corporation who has submitted a sub-bid to a Bidder, or who has quoted prices on materials to a Bidder, is not hereby disqualified from submitting a sub-bid or quoting prices to other Bidders, but is disqualified from submitting a Bid for the work as a Bidder. All Bidders are disqualified from submitting sub-bids or quoting material prices to other Bidders.

6.2 SUBMISSION PROCEDURE

- A. Bidders shall be solely responsible for the delivery of their bids in the manner and by the time prescribed.
- B. Submit one copy of the executed Bid on the Bid Form provided, signed (and sealed, when applicable) with the required security and supporting documents in a sealed opaque envelope, addressed to the Owner, clearly identified with Bidder's name, project name and number and the date and hour of the opening of the Bids on the outside.

6.3 BID ACCEPTABILITY

- A. Bids that are unsigned, improperly signed or sealed, conditional, illegible, obscure, contain arithmetical errors, erasures, alterations, or irregularities of a similar kind, will, at the discretion of the Owner, be declared unacceptable, and be rejected.
- B. Failure to provide security deposit, bonding or to meet the insurance requirements will invalidate the bid.

7 BID ENCLOSURES/REQUIREMENTS**7.1 SECURITY DEPOSIT**

- A. A bid security (a certified or cashier's check, or a bid bond) in an amount equal to ten percent (10%) of the total Bid (base plus all additive optional prices and applicable local transaction privilege or use taxes or both) must accompany each Bid when submitted. Only Bid Bonds utilizing the form contained in the Bid Documents or a photocopy thereof are acceptable.
- B. A Bid Bond must name the Owner as obligee, contain the name and number of the project, and be signed and sealed by the Bidder and surety.
- C. A certified or cashier's check must be made in the name of the Owner.
- D. The security deposit will be returned after delivery to the Owner of the required Performance and Payment Bonds and insurance certificates, and signing of the Contract by the acceptable Bidder.

Section 00100

INSTRUCTION TO BIDDERS

- E. Include the cost of bid security of the Bid Price.
- F. After a contract has been awarded, all securities will be returned to the respective Bidders.
- G. If no contract is awarded, all security deposits will be returned.

7.2 QUALIFICATIONS OF CORPORATE SIGNATURE

- A. If the Bidder is incorporated, a properly completed Qualification of Corporation Signature form should be submitted with the Bid.
- B. The certification must be made by an authorized Office of the corporation other than the individual named in the top portion of the form.

7.3 QUALIFICATION OF LIMITED LIABILITY COMPANY SIGNATURE

- A. If the bidder is a Limited Liability Company, a properly completed Qualification of Limited Liability Company Signature form should be submitted with the Bid.
- B. The certification must be made by a company member other than the individual named in the top portion of the form.

7.4 PERFORMANCE ASSURANCE

- A. Accepted Bidder: Provide Performance and Payment Bonds as described in Section 16 of the General Conditions.
- B. Subcontracts of \$100,000 or more in value: Provide Performance Bond as described in Section B of the General Conditions.
- C. Include the cost of performance bonds in the Bid Price.

7.5 INSURANCE

- A. Accepted Bidder: Provide insurance certificates as required by the General Conditions as amended.

7.6 BID FORM REQUIREMENTS

- A. Complete all requested information in the Bid Form and Appendices.
- B. Bids shall be submitted only on the forms contained herein or photocopies thereof. All required signatures and initials must be original manual ink signatures or initials of the signer. Copies of signed Bid Form, Appendix A or Bid Bond are not acceptable. Bidders are cautioned to complete all blank spaces on all Bid Forms and Appendices, including dollar amounts (in both words and numerals) for the Base Bid. Failure to complete all blanks shall be a basis for rejection of the bid.

Section 00100

INSTRUCTION TO BIDDERS

- C. All entries on Bid Forms must be entered in ink or typewritten. No alterations or interlineations are permitted to the printed content of the Bid Form. Any alterations or erasures in the content furnished by the Bidder shall be made before submission and be initialed by the signer of the Bid Form or by signer's authorized representative. An authorization letter to the Owner naming such a representative, and bearing the original manual ink signature of the signer of the Bid Form, shall be attached to the Bid Form when this procedure is used.
- D. The Arizona Revised Statutes contain the following provision in Subsection G of Section 41-2533: "The amount of any applicable transaction privilege or use tax of a political subdivision of this state is not a factor in determining the lowest bidder." To enable the Owner to determine the apparent low bidder in accordance with this provision, all bidders must calculate their bid prices (base bid and all optional prices) excluding all applicable local transaction privilege or use taxes.

Upon Owner's request, the apparent low Bidder shall furnish complete and documented information as required for Owner to determine the dollar amount to be added to the low Bid for any local transaction privilege or use taxes or either or both, payable by the Bidder to cities, counties or other political subdivisions within the State of Arizona as a result of the Bidder being located within that political subdivision. The Owner will use this information only to determine the amount of the lump sum Contract Price for the purpose of the contract award. PLEASE NOTE that taxes levied by the State of Arizona, which are effective statewide, are not to be included in such post-bid tax information, but are to be included in the Bid Price (s)

7.7 FEES FOR CHANGES IN THE WORK

- A. Bidders are advised that section 28 of the General Conditions limits the fees that can be charged for Changes in the Work.

7.8 BID FORM SIGNATURES

- A. The Bid Form shall be signed by the bidder as follows:
1. Sole Proprietorship: Signature of sole proprietor in the space provided. Circle or underline the words "Sole Proprietor" above the signature.
 2. Partnership: Signature of a partner in the space provided. Circle or underline the word "Partner" above the signature.
 3. Corporation: Signature of a duly authorized signing officers in their normal signature. Insert the officer's capacity in which the signing officer acts, under the signature. Affix the corporate seal. Circle or underline the word "Corporation" above the signature. A properly executed Qualification of Corporation Signature form or a copy of the authorizing by-law resolution of the board of directors must also be submitted with the Bid Form in the bid envelope.
 4. Limited Liability Company: Signature of duly authorized company member signing in their normal signature. Insert the capacity in which the member acts

Section 00100

INSTRUCTION TO BIDDERS

above the signature and circle or underline the words "Limited Liability Company" above the signature. A properly executed Qualification of Limited Liability Company Signature form must also be submitted with the Bid Form in the bid envelope.

5. Joint Venture: Each party of the joint venture shall execute the Bid Form under their respective seals in a manner appropriate to such party as described above. Insert words clearly indicating Bidder is a joint venture.

7.9 ADDITIONAL BID INFORMATION

A. Submit the following Appendices concurrent with bid submission:

1. Document 00401 – Appendix A – Subcontractors: Include the names of all Subcontractors and the portions of the Work they will perform.
2. **[Document 00402 – Appendix B – Unit Prices: Include a listing of unit prices specifically requested by the Contract Documents.]**
3. **[Document 00403 – Appendix C – List of Optional Prices: Include the cost variation to the Bid Price applicable to the Work described in Section [_____]].**

B. Submit the following Appendices **[[24] hours after bid submission:]**

1. Document 00404 – Appendix D – List of Separate Prices: Include a listing of separate prices as specifically requested in the Contract Documents.
2. Document 00405 – Appendix E – Cost Breakdown identifies the Bid Price/Sum segmented into portions as requested.
3. Document 00406 – Appendix F – Supplementary Architectural Information.
4. Document 00407 – Appendix G – Supplementary Mechanical and Electrical Information.
5. Document 00408 – Appendix H – List of Equipment.

8 SELECTION AND AWARD

8.1 CONTRACT

A. The award of the contract, if made by the Owner, will be made to the responsible Bidder submitting the lowest responsive Base Bid.

8.2 OPTIONAL PRICES

A. All Optional Prices requested by the Owner are described in the Supplements to the Bid Form and in Division 01 of the Specifications. In the Supplements to Bid Form all blank spaces, opposite the correspondingly numbered Options, shall be completed

Section 00100

INSTRUCTION TO BIDDERS

by inserting the exact amount to be added to, or deducted from, the Base Bid for each particular Option. The Owner reserves the right to choose none, or any combination of the Optical Prices.

- B. Bids will be evaluated on the base bid price. After determination of a successful bidder, consideration will be given to options.

8.3 UNIT PRICES

- A. All Unit Prices requested by the Owner are described in the Supplements to Bid Form and in Division 01 of the Specifications. In the Bid Form, all blank spaces opposite the correspondingly number Unit Prices, shall be completed by inserting the exact amount to be added to, or deducted from, the Contract Sum for each unit of work added to, or deducted from, the scope of the Contractor's work under the Contract by means of applicable unit pricing.
- B. The Owner reserves the right to accept or reject any individual unit price when awarding the Contract and to utilize either a negotiated lump sum price or applicable unit price (as contained in the Contract), or a combination thereof, to adjust the Contract Sum for variations in the Contractor's scope of work. This determination will be made by Owner when authorizing the work to be performed.

9 BID ACCEPTANCE/REJECTION

9.1 DURATION OF BID

- A. Bid shall remain open to acceptance and shall be irrevocable for a period of **thirty (30) [sixty (60)] [ninety (90)]** [_____] days after the bid closing date.

9.2 ACCEPTANCE OF BID

- A. The Owner reserves the right to accept or reject any or all Bids, and to waive or decline to waive any irregularities in any Bid received.
- B. After acceptance, the Owner will issue to the successful Bidder a written Notice of Intent to Award with a copy to all Bidders.

10 OWNER POLICIES/REGULATIONS

10.1 APPROVED APPLICATOR LETTER

- A. If roofing work is involved in the project, the successful bidder must provide, at the preconstruction conference, a copy of the roofing subcontractor's Approved Applicator Letter as issued by the approved roofing manufacturer.

10.2 POLICY ON SEXUAL HARASSMENT

- A. The successful contractor will be required to comply with University of Arizona Policy on Sexual Harassment (adopted 12/82 – revised 11/88). The University prohibits sexual harassment by any person on University premises or at University affiliated functions.

10.3 DRUGS, ALCOHOL AND FIREARMS

- A. Bidders are notified that the University of Arizona requires its construction sites to be drug, alcohol, and firearm free areas, and that the University considers the presence of any person either using or possessing any of these items to be a violation of the provisions of Subsection 11.2 of the General Conditions. Therefore, the successful Bidder, as Contractor, shall insure that all persons on the site with Contractor's permission or in any way connected with the Contractor observe the prohibitions against the possession or use of drugs, alcohol, or firearms.

10.4 RECYCLING AND REUSE OF SALVAGED/SURPLUS AND WASTE MATERIALS

- A. The University of Arizona encourages its construction contractors to consider the recycling of reuse of all usable salvaged and surplus building materials through the program operated by Habitat Restore – TMM or any similar non-profit program operated by a responsible independent social service agency.
- B. The University of Arizona encourages its construction contractors to consider the recycling of all corrugated cardboard boxes used for the shipping of construction materials. Deliver the boxes to Campus location designated by Owner. There is no charge for this service.

END OF INSTRUCTION TO BIDDERS

1 SUMMARY

1.1 DOCUMENTS INCLUDES

A. Contract Documents

1. Definitions
2. Contract Documents Identification
3. Inquiries/Addenda
4. "Or Equal" Products

B. Site Assessment

1. Site Examination

C. Qualifications

1. Subcontractors

D. Guaranteed Maximum Price

1. Optional Prices **[Not Used]**
2. Unit Prices **[Not Used]**

E. Owner Prices/Regulations

1. Approved Applicator letter
2. Policy on Sexual Harassment
3. Drugs, Alcohol, and Firearms
4. Recycling and Reuse of Salvaged/Surplus and Waste Materials
5. Payment to Subcontractors

2 CONSTRUCTION DOCUMENTS

2.1 DEFINITIONS

Section 00100

INSTRUCTIONS TO CM@RISK

- A. Definitions are generally as set forth in the General Conditions of the Agreement, and are applicable to these Construction Documents. Additionally, wherever the word "Owner" is used, it shall mean the Arizona Board of Regents. Wherever the words "Architect", "Engineer", or "Design Professional" are used, they shall mean [DP Name] [Address].
- B. Wherever the word "Contractor" is used in these specifications it shall mean Construction Manager at Risk or the sub-contractor, as indicated by the context in which it appears.
- C. Wherever the title "Construction Manager" appears in Division 1 of these specifications, it shall mean the Owner's Construction Project Manager.
- D. Guaranteed Maximum Price Documents: Consist of the Contract Documents including Instructions to CM@Risk, Information Available, and all items listed in the Table of Contents of the Project Manual.
- E. Contract/Agreement: THE UNIVERSITY OF ARIZONA® STANDARD FORM AGREEMENT BETWEEN OWNER AND CM@RISK ON THE BASIS OF A GUARANTEED MAXIMUM PRICE including issued Addenda.

2.2 CONTRACT DOCUMENT IDENTIFICATION

- A. The Contract Documents are dated [_____] and identified as Project number [_____] **[Project Name]** as prepared by **[DP]** under the direction of the President of the University of Arizona for the Arizona Board of Regents.

2.3 INQUIRIES/ADDENDA DURING PREPARATION OF GUARANTEED MAXIMUM PRICE (GMP)

- A. Should the CM@Risk find discrepancies in, or omissions from the drawings, specifications or other construction documents, or should be in doubt as to their meaning, they should at once notify in writing, **[DP]** [Address], phone [()] who will send a written instruction, correction or interpretation to the CM@Risk in the form of an Addendum. The Owner will not be responsible for any explanations or interpretations except those duly issued in the form of written Addenda. Addenda so issued during the time of preparing the Guaranteed Maximum Price shall be acknowledged on the GMP form and will be made part of the construction documents, and all resultant costs shall be included in the Guaranteed Maximum Price.
- B. Should the CM@Risk have questions after complying with the above instruction, they shall notify [FDC Contact] UA Facilities Design and Construction not later than five (5) days prior to the submission of the GMP by calling the following: [(520) 62*-****].

Section 00100

INSTRUCTIONS TO CM@RISK

2.4 "OR EQUAL" PRODUCTS

- A. The Construction Manager @ Risk represents that the Guaranteed Maximum Price is based upon the materials and equipment described in the Construction Documents.
- B. Any Pre-GMP requests for substitution of products shall follow the procedure specified herein.
- C. No "or equal" products will be allowed unless written approval has been obtained for the proposed "or equal" material or equipment prior to the submission of the GMP. Such prior approval shall be by the Architect, in writing, in the form of an Addendum to the Construction Documents.
- D. In order for prior approval to be given, a written request for approval of such products shall be submitted at least **[fourteen (14)]** calendar days prior to submission of the GMP, using the Form included at the end of these Instructions, and the material submitted shall include a complete description, drawings, specifications, cut sheets, performance and test data and any other information necessary for a complete evaluation.
- E. Wherever the words "or equal" occur in the Construction Documents, such wording shall be construed to mean "or equal product as approved by the Architect/Engineer prior to submission of the GMP."
- F. For information regarding substitution of material or equipment after the GMP has been accepted, see Subsection 1.7 of Section 01600 of the Specifications.
- G. For information regarding substitution of subcontractors see Section 4.1, Subcontractors, of these Instructions to CM@Risk.

3 SITE ASSESSMENT

3.1 SITE EXAMINATION

- A. Before submitting the Guaranteed Maximum Price, the Construction Manager @ Risk shall examine the site and fully determine the conditions under which he will operate in performing the work under this contract. No allowance will be made subsequently for failure to do so. The Construction Manager @ Risk shall be satisfied as to the nature and location of the work and the general and local conditions. The Construction Manager @ Risk shall gain full knowledge as to transportation, disposal, handling and storage of materials, availability of water, electric power, and all other facilities in the area which will have a bearing on the performance of their work.
- B. Any failure by the Construction Manager @ Risk to acquaint themselves with all the available information shall not relieve them from any responsibility for performing their work properly. No additional compensation shall be allowed for conditions reasonably ascertainable by the CM@Risk prior to submission of the GMP.

Section 00100

INSTRUCTIONS TO CM@RISK

- C. Construction Manager @ Risk is cautioned that certain work hour restrictions (Owner, City of Tucson, or both) may apply to this project, and that all such applicable restrictions will be strictly enforced. Refer to Section 01010 for details of Owner regulations.

4 QUALIFICATIONS

4.1 SUBCONTRACTORS

- A. The Owner reserves the right to reject a proposed Subcontract for reasonable cause.
- B. The conditions under which the University will consider a request for substitution of a subcontractor are:
1. Owner actions, such as the selection of Optional Price(s) or optional work, makes a subcontractor's bid non-responsive or significantly non-competitive.
 2. Written admission by the subcontractor of its inability to perform the work included in its bid or subcontract as required by the Construction Documents.
 1. A written refusal by the subcontractor to enter into a subcontract for the price and scope of work included in its bid on bid day, utilizing the standard subcontract form required by Subsection 4.1.C below.
 2. Insolvency or bankruptcy, cessation of business operations, or other inability of the subcontractor to perform the work bid or contracted for.
 3. Persistent or repeated failure or refusal by the subcontractor to perform its work as reasonably expected by the CM@Risk to enable the CM@Risk to meet its contractual commitment to the University.
 4. No license or improper license for the work included in the bid or subcontract.
- C. When the CM@Risk proposes to perform certain items of work with its own forces and so indicates on the List of Subcontractors, the CM@Risk shall, as Contractor, perform the work so designated unless the Owner has a reasonable objection to such arrangement prior to the acceptance of the GMP. The University of Arizona requires that all subcontracts on University projects be executed using AIA Form A401-1997. This form shall be fully conformed to the provisions of the Prime Contract, including, but not limited to, the following changes:
1. Delete Paragraph 1.2 in its entirety.
 2. Delete from the first sentence of Paragraph 2.1 the words "the provisions of the edition of AIA Document A201 current as of the date of this Agreement apply to this Agreement pursuant to Paragraph 1.2 and".
 3. Delete Paragraph 3.2.5 in its entirety.

Section 00100

INSTRUCTIONS TO CM@RISK

4. Add Paragraph 6.3 as follows:

“This Article 6 shall not be deemed a limitation of rights or remedies which the Subcontractor may have under Federal law or under applicable labor or material payment bonds unless such rights or remedies are expressly waived by the Subcontractor.”

5. Delete the wording “along with reasonable overhead and profit on the Work not executed” at the end of Paragraph 7.2.4.
6. Delete Paragraphs 13.7.2, 13.7.3, and 13.8 in their entirety.

As evidence of compliance with this Subsection, the Contractor shall furnish to the Owner, within the time limits stated in Section 01300 of the Project Manual, one fully executed copy of all subcontracts for this project. Each copy shall consist of the subcontract agreement (Form A401), with compensation amounts deleted but including all special or supplementary conditions applicable to the subcontract.

5 GUARANTEED MAXIMUM PRICE

- A. All Optional Prices requested by the Owner are described in Division 01 of the Specifications. The Guaranteed Maximum Price shall indicate the exact amount to be added, or deducted from, the Guaranteed Maximum Price for each particular Option. The Owner reserved the right to choose none, or any combination of the Optional Prices.

6 OWNER POLICIES/REGULATIONS

A. APPROVED APPLICATOR LETTER

1. The CM@Risk must provide, at the preconstruction conference, a copy of the roofing subcontractor’s Approved Applicator Letter as issued by the approved roofing manufacturer.

B. POLICY ON SEXUAL HARASSMENT

1. The CM@Risk will be required to comply with University of Arizona Policy on Sexual Harassment (adopted 12/82 – revised 11/88). The University prohibits sexual harassment by any person on University premises or at University affiliated functions.

C. DRUGS, ALCOHOL AND FIREARMS

1. The University of Arizona requires its construction sites to be drug, alcohol, and firearm free areas, and that the University considers the presence of any person either using or possessing any of these items to be a violation of the provisions of Subsection 2.6 of the General Conditions. Therefore, the Construction Manager @ Risk shall insure that all persons on the site with Contractor’s permission or in

any way connected with the CM@Risk observe the prohibitions against the possession or use of drugs, alcohol, or firearms.

D. RECYCLING AND REUSE OF SALVAGED/SURPLUS AND WASTE MATERIALS

1. The University of Arizona encourages its construction contractors to consider the recycling of reuse of all usable salvaged and surplus building materials through the program operated by Habitat Restore – TMM or any similar non-profit program operated by a responsible independent social service agency.
2. The University of Arizona encourages its construction contractors to consider the recycling of all corrugated cardboard boxes used for the shipping of construction materials. Deliver the boxes to Campus location designated by Owner. There is no charge for this service.

END OF SECTION

DIVISION 0

UA No.

Section 00101

INQUIRIES

Project: _____ Date: _____

Subject: _____

Reference Drawings: _____ Spec Section: _____

Information Requested: _____

Attachments: _____

Signed: _____

END OF SECTION

DIVISION 00

UA No.

Section 00102

Prior Approval Request Form

PRIOR APPROVAL REQUEST FORM

UA Project Name:

UA Project No.:

We hereby submit for your consideration the following material/product in lieu of the specified item for the above referenced product.

Section No.:

Page:

Paragraph / Line:

Item:

Proposed Substitution:

Attach complete product descriptions, drawings, specifications, and any other information or data to fully describe the proposed item.

A. The proposed item meets or exceeds specification requirements?

Yes:

No:

B. Will any changes be required to building design in order to properly install the proposed item?

Yes:

No:

If yes, please explain:

8/11/05

DIVISION 00

UA No.

Section 00102

Prior Approval Request Form

PRIOR APPROVAL REQUEST FORM

UA Project Name:

UA Project No.:

C. Supplier is responsible for all changes to the building design, including engineering and drawings costs, caused by requested approval/substitution?

Yes:

No:

D. List all differences between proposed substitution and specified item.

SPECIFIED ITEM

PROPOSED ITEM

SPECIFIED ITEM	PROPOSED ITEM

E. Does substitution affect drawing dimensions?

If yes, please explain:

F. What affect does the substitution have on other trades?

Yes:

No:

G. Proposed product is subject to all requirements of specifications, including warranties.

Yes:

No:

8/11/05

DIVISION 00

UA No.

Section 00102

Prior Approval Request Form

PRIOR APPROVAL REQUEST FORM

UA Project Name:

UA Project No.:

H. Will proposed substitution affect progress schedule?

Yes:

No:

If yes, please explain:

I. Will maintenance and service parts be locally available for proposed substitution?

Yes:

No:

J. Will proposed substitution require more license fees or royalties than specified product?

Yes:

No:

K. Will proposed product meet all requirements of reviewing agencies (health, life, safety, fire, etc.)?

Yes:

No:

If no, please explain:

Please quantify or explain benefits to the Owner:

Submitted By:

Representative:

Company:

8/11/05

DIVISION 00

UA No.

Section 00102

Prior Approval Request Form

PRIOR APPROVAL REQUEST FORM

UA Project Name:

UA Project No.:

Address:

Phone:

Representative's Signature:

Date:

For Architect's Use Only:

Accepted:

Accepted As Noted:

Rejected:

Received Too Late:

By:

Date:

Remarks:

END OF SECTION

Section 00200

INFORMATION AVAILABLE [TO BIDDERS]

1 GENERAL

The following documents are available for review at **[list the offices of the Architect, Engineers, Construction Manager, plan rooms, etc. as applicable]** but are not part of the Contract Documents and are made available to the Bidders for their convenience only.

2 SUBSURFACE SOIL INVESTIGATION

- A. A subsurface soil investigation has been made at Project Site. The resultant report on soil and foundation investigation(s) was prepared by: _____ **(Firm)** _____, _____ **(Address)** _____, _____ **(phone #)** _____, **Job No.** _____, **Dated** _____, for Owner's use in preparation of site and structural foundation design and engineering for this Project.
- B. Making this data on subsurface conditions available is not intended by the Owner as any representation or warranty, either express or implied, that the conditions indicated are representative of those existing throughout the site or any part thereof, or of any continuity between borings. It is expressly understood and agreed that the Owner will not be responsible for interpretations or conclusions drawn therefrom by Contractor. Bidders are expected to examine the site of the Work, and will be permitted to conduct their own subsurface explorations upon proper application to the Owner.
- C. The recommendations contained in the report shall not be construed as a requirement of this Contract, unless specifically referenced in the Contract Documents.

3 AS BUILT DRAWINGS

- A. The following documents are available for review at the [_____], **[address]** [_____]. This information is NOT part for the Contract Documents, and is made available to bidders **[CM@Risk]** for convenience only.
 - 1. As Build Drawings for [_____].

4 TOPOGRAPHIC SURVEY

- A. A copy of a topographic survey with respect to the project site is available for viewing at the office of the **[Owner] [Architect/Engineer] [Construction Manager]**

[_____] titled [as _____]

Dated [_____] and prepared by:

[_____]
- B. This survey identifies grade elevations prepared primarily for the use of the Architect/Engineer in establishing new grades and identifying natural water shed.

DIVISION 00

UA No.

Section 00200

INFORMATION AVAILABLE [TO BIDDERS]

END OF INFORMATION AVAILABLE [TO BIDDERS]

DIVISION 00

UA No.

Section 00300

Bid Form - Stipulated Sum

To: Arizona Board of Regents
Administration Building
Tucson, Arizona 85721

Project Name: [_____]
Project No: [_____]

Date: _____

Submitted by:

(full name) _____

(full address) _____

(Arizona License) Class _____ Number _____
 Class _____ Number _____
 Class _____ Number _____

Gentlemen:

1. OFFER

A. In compliance with your Notice to Contractors of Intent to Receive Bids, Instructions to Bidders, University Procurement Code and applicable State and Federal Regulations, the undersigned hereby offers to furnish the necessary materials and equipment to perform the work, and to provide necessary transportation for the **[(project name and number) _____]** in strict accordance with the Contract Documents prepared by **[(name and address of Architect) _____]**, and agrees upon receipt of a Notice of Intent to Award showing acceptance of this bid within **[thirty (30)] [sixty (60)] [ninety (90)] [_____] calendar days** after date of opening thereof, that he will execute a contract in accordance with the Bid as accepted, and that he will give performance and payment bonds, with sufficient surety, each in the amount of one hundred percent (100%) of the Contract price, and submit required insurance certificates, all within five (5) working days after the receipt of the Notice of Intent To Award the Contract.

The Undersigned Bidder hereby agrees that he will perform all the work shown on the contract documents, excluding all applicable local transaction privilege or use taxes or both and any Optional Prices listed on Appendix C, for the sum of:

Issued September 2000

_____ Dollars (\$ _____), which sum represents the BASE BID including all work as indicated on the drawings and specifications.

- B. Excluded from the above amounts are all applicable local transaction privilege or use taxes. The apparent low Bidder shall furnish within 48 hours after Owner's request, complete detailed and documented information setting forth the amounts of such taxes and the political subdivisions(s) to which they will be paid.
- C. Enclosed is the required Bid Security in an amount which is not less than ten percent (10%) of the above total bid (base plus all additive optional prices and applicable local transaction privilege or use taxes).

2. ACCEPTANCE

- A. This offer shall be open to acceptance and is irrevocable for **[thirty (30)] [sixty (60)] [ninety (90)] [_____]** days from the bid closing date.
- B. If this Bid is accepted by the Owner within the time period stated above, Bidder agrees that he will:

Furnish the required bonds and insurance certificates within five (5) working days of receipt of Notice of Intent to Award the Contract.

Execute the Agreement within **[seven] [_____]** days of receipt of Agreement for signature.

Commence work in accordance with the written Notice to Proceed to be issued by the Owner after complete execution of the Agreement.

- C. If this bid is accepted within the time stated, and Bidder fails to comply in all respects with the requirements of the Bid Documents, the security deposit shall be forfeited as damages to the Owner by reason of the Bidder's failure.
- D. In the event this Bid is not accepted within the time stated above, the required security deposit shall be returned to the undersigned, in accordance with the provisions of the Instructions to Bidders; unless a mutually satisfactory arrangement is made for its retention and validity of this Bid for an extended period of time.

3. CONTRACT TIME

It is understood and agreed that the Work under the Contract shall be commenced by the Undersigned Bidder, as Contractor, if awarded the Contract for the project, in accordance

Section 00300

Bid Form - Stipulated Sum

with the Notice To Proceed and shall be substantially completed by the Undersigned Bidder, as Contractor, not later than [_____ (__) calendar days after the commencement date shown in the Notice To Proceed] [_____, 20__].

4. LIQUIDATED DAMAGES

If the Work[or **designated portion thereof**] is not substantially completed by the designated date, the Contractor shall pay to the Owner _____ dollars (\$____.00) as liquidated damages for each day after the designated date during which the Contractor fails to substantially complete the Work [or **designated portion thereof**]. If the Work is not totally and finally complete by the date designated in the Certificate of Substantial Completion, the Contractor shall pay to the Owner _____ dollars (\$____.00) as liquidated damages for each day after the designated date during which the Work remains uncompleted.

5. ADDENDA

The following Addenda have been received by the undersigned Bidder and the modifications to the Bid Documents noted therein below have been considered and all costs are included in the Bid Sum.

Addendum # Dated

Addendum # Dated

Addendum # Dated

Addendum # Dated

Addendum # Dated

6. SUPPLEMENTS TO BID FORM

Submit the following Appendices concurrent with Bid submission:

Document 00401 - Appendix A - List of Subcontractors: Include the names of all Subcontractors and the portions of the Work they will perform.

[Document 00402 - Appendix B - List of Unit Prices: Include a listing of unit prices specifically requested by the Contract Documents.]

Section 00300

Bid Form - Stipulated Sum

[Document 00403 - Appendix C - List of Optional Prices: Include the cost variation to the Bid Sum applicable to the Work described in Section [____].]

[Submit Document 00400] - Supplements to Bid Form and following Appendices [____] [24] [48] [____] hours after submission of this Bid.]

[Submit Document 00404 - Appendix D - List of Separate Prices: Include a listing of separate prices as specifically requested in the Contract Documents.]

[Submit Document 00405 - Appendix E - Cost Breakdown identifies the Bid Sum segmented into portions as requested.]

[Submit Document 00406 - Appendix F - List of Supplementary Architectural Information.]

[Submit Document 00407 - Appendix G - List of Supplementary Mechanical and Electrical Information.]

[Submit Document 00408 - Appendix H - List of Equipment.]

7. BID FORM SIGNATURE(S)

The Corporate Seal of

DATE _____

(Official Name of Firm)
(Individual) (Partnership) (Corporation)
(Limited Liability Company) (Other - give details)

(Business Address)

BY _____
(Signing official's name-printed or typewritten)

DIVISION 00

UA No.

Section 00300

Bid Form - Stipulated Sum

(Signature of Authorized Official)

(Title)

If the Bid is a joint venture or partnership, add additional forms of execution for each member of the joint venture in the appropriate form or forms above in the space below.

END OF BID FORM - STIPULATED SUM

DIVISION 00

UA No.

Section 00400

Supplements to Bid Form

To: Arizona Board of Regents
Administration Building
University of Arizona
Tucson, Arizona 85721

Project Name: [_____]

Project No.: [_____]

Date: [_____]

Submitted by: [_____] (full name)

(full address) [_____]

[_____]

In accordance with Document 00100 - Instructions to Bidders and Document 00300 - Bid Form - Stipulated Price, included are the Supplements To Bid Form Appendices listed below. The information provided shall be considered an integral part of the Bid Form.

These Appendices are as follows:

Document 00401 - Appendix A - List of Subcontractors: Include the names of all Subcontractors and the portions of the Work they will perform.

Document 00402 - Appendix B - List of Unit Prices: Include a listing of unit prices specifically requested by the Contract Documents.

Document 00403 - Appendix C - List of Optional Prices: Include the cost variation to the Bid Sum applicable to the Work described in Section 01030.

Document 00404 - Appendix D - List of Separate Prices: Include a listing of separate prices as specifically requested in the Contract Documents.

Issued September 2000

DIVISION 00

UA No.

Section 00400

Supplements to Bid Form

Document 00405 - Appendix E - Cost Breakdown identifies the Bid Sum segmented into portions as requested.

Document 00406 - Appendix F - List of Supplementary Architectural Information.

Document 00407 - Appendix G - List of Supplementary Mechanical and Electrical Information.

Document 00408 - Appendix H - List of Equipment.

SUPPLEMENTS TO BID FORM SIGNATURE(S)

DATE _____

(Official Name of Firm)
(Individual) (partnership) (Corporation) (Limited Liability Company) (Other)

(Business Address)

BY _____
(Signing official name-printed or typewritten)

(Signature of authorized official)

(Title)

END OF SUPPLEMENTS TO BID FORM

DIVISION 00

UA No.

Section 00401

Appendix A - List of Subcontractors

PROJECT NAME: _____
PROJECT NUMBER: _____

This Appendix A shall be sealed in a separate envelope and shall be submitted along with Document 00300, Bid Form - Stipulated Price, both of which shall be placed in an outer sealed envelope. The inner envelope shall be marked "Appendix A - List of Subcontractors".

The Bidder shall list below for each portion of the Work shown, the name of the firm being proposed to perform that portion of the work. Where the Bidder is proposing to perform the item of work with its own forces, the Bidder's name shall be entered and the work shall be performed per the provisions of Subsection 5.2.D of the Instructions to Bidders. After entering all the required information, Bidder shall certify the entries by signing this form in the space provided at the end.

Bidder shall be prepared to furnish documentary evidence of subcontractor license numbers and expiration dates within 24 hours after request for same by the Owner.

Proof of ability to obtain a performance bond shall be submitted for each subcontract bidder subject to the provisions of subsection 5.2.G of the Instructions to Bidders.

NOTE: See Section 5, Subcontractors, of the Instructions to Bidders for information regarding substitution of subcontractors.

*Note To Contractor: All items or "portions of the work" exceeding \$10,000 in cost or 5% of the total construction cost must be entered, by trade in the "Portion of Work" column. Where the Owner has indicated that the material or equipment suppliers names are desired also, use Appendices F, G and/or H as applicable.

Issued September 2000

DIVISION 00

UA No.

Section 00401

Appendix A - List of Subcontractors

PORTION OF WORK	FIRM NAME
1.	
2.	
3.	
4.	
5.	
6.	
7.	
8.	
9.	
10.	
11.	
12.	
13.	

SIGNED BY _____

BIDDER FIRM: _____

END OF SECTION

DIVISION 00

UA No.

Section 00402

Appendix B - List of Unit Prices

PROJECT NAME: _____
PROJECT NUMBER: _____

The following is the list of Unit Prices for the bid submitted by:

(Bidder)

Dated _____ and which is an integral part of the Bid Form.

The following are Unit Prices for changes to specific portions of the Work as listed, and are applicable to variations from the Contract Documents only in accordance with Section 8.3 of the Instructions to Bidders.

ITEM DESCRIPTION	UNIT	UNIT PRICE
[_____]	[_____]	_____
[_____]	[_____]	_____
[_____]	[_____]	_____
[_____]	[_____]	_____
[_____]	[_____]	_____

END OF SECTION

DIVISION 00

UA No.

Section 00403

Appendix C - List of Optional Prices

PROJECT NAME: _____
PROJECT NUMBER: _____

The following is the list of Optional Prices for the bid submitted by:

(Bidder) _____

Dated _____ and which is an integral part of the Bid Form.

The following amounts shall be added to or deducted from the Base Bid Sum. Refer to Section **[01019 - Contract Considerations] [01030 - Optional Prices]**: Schedule of Optional Prices.

Optional Price # 1 [Add] [Deduct] \$ _____

Optional Price # 2 [Add] [Deduct] \$ _____

END OF SECTION

DIVISION 00

UA No.

Section 00404

APPENDIX D - LIST OF SEPARATE PRICES

PROJECT NAME: _____
PROJECT NUMBER: _____

The following is the list of Separate Prices for the bid submitted by:

(Bidder) _____

Dated _____ and which is an integral part of the Bid Form.

ITEM DESCRIPTION

VALUE

Separate Price # 1:

[_____]

\$ _____

Separate Price # 2:

[_____]

\$ _____

END OF SECTION

Issued September 2000

DIVISION 00

UA No.

SECTION 00405

APPENDIX E - COST BREAKDOWN

PROJECT NAME: _____
PROJECT NUMBER: _____

The following is a Cost Breakdown for the bid submitted by:

(Bidder) _____

Dated _____ and which is an integral part of the Bid Form.

ITEM OF WORK	VALUE
	[Overhead] [Profit] [_____] [Included] [Excluded]
[_____]	\$ _____
[_____]	\$ _____
[_____]	\$ _____
[_____]	\$ _____
[_____]	\$ _____
[_____]	\$ _____

END OF SECTION

Issued September 2000

DIVISION 00

UA No.

Section 00406

Appendix F - List of Supplementary Architectural Information

PROJECT NAME: _____
PROJECT NUMBER: _____

The following is Supplementary Architectural Information for the bid submitted by:

(Bidder) _____

Dated _____ and which is an integral part of the Bid Form.

COMPONENT OR ITEM	MANUFACTURER
[_____]	_____
[_____]	_____
[_____]	_____
[_____]	_____
[_____]	_____
[_____]	_____

END OF SECTION

Issued September 2000

DIVISION 00

UA No.

Section 00407

**Appendix G - List of Supplementary
Mechanical & Electrical Information**

PROJECT NAME: _____
PROJECT NUMBER: _____

The following is Supplementary Mechanical and Electrical Information for the bid submitted by:

(Bidder) _____

Dated _____ and which is an integral part of the Bid Form.

COMPONENT OR ITEM	MANUFACTURER
[_____]	_____
[_____]	_____
[_____]	_____
[_____]	_____
[_____]	_____
[_____]	_____

END OF SECTION

Issued September 2000

DIVISION 00

UA No.

Section 00408

Appendix H - List of Equipment

PROJECT NAME: _____
PROJECT NUMBER: _____

The following is a List of Equipment for the bid submitted by:

(Bidder) _____

Dated _____ and which is an integral part of the Bid Form.

COMPONENT OR ITEM	MANUFACTURER
[_____]	_____
[_____]	_____
[_____]	_____
[_____]	_____
[_____]	_____
[_____]	_____

END OF SECTION

Issued September 2000

BID BOND

KNOW ALL MEN BY THESE PRESENTS, that we, the undersigned,

_____ as Principal, and

_____ as Surety, are hereby held and

firmly bound unto the Arizona Board of Regents for and on behalf of the University of Arizona as Owner in the penal sum of ten percent (10%) of its total Bid (base bid plus all additive optional prices and applicable local transaction privilege or use taxes or either for the payment of which, well and truly to be made, we hereby jointly and severally bind ourselves, our heirs, executors, administrators, successors and assigns. Signed, this ____ day of _____, 20__.

The condition of the above obligation is such that whereas the Principal has submitted to the Owner a certain Bid, attached hereto and hereby made a part hereof to enter into a contract in writing, for Project No. [____ (insert project number and title)_____]

NOW THEREFORE,

- (a) If said Bid shall be rejected, or in the Alternate,
- (b) If said Bid shall be accepted and the principal shall execute and deliver a contract in the Form of Contract provided (properly completed in accordance with said Bid) and shall furnish a bond for his faithful performance of said contract, and for the payment of all persons performing labor or furnishing materials in connection therewith, and shall in all other respects perform the agreement created by the acceptance of said Bid, then this obligation shall be void, otherwise the same shall remain in force and effect; it being expressly understood and agreed that the liability of the Surety for any and all claims hereunder shall, in no event, exceed the penal amount of this obligation as herein stated.

DIVISION 00

UA No.

Section 00410

Bid Bond

The Surety, for value received, hereby stipulates and agrees that the obligations of said Surety and its bond shall be in no way impaired or affected by any extension of the time within the Owner may accept such Bid; and said Surety does hereby waive notice of any such extension.

IN WITNESS WHEREOF, the Principal and the Surety have hereunto set their hands and seals, and such of them as are corporations have caused their corporate seals to be hereto affixed and these presents to be signed by their proper officers, the day and year first set forth above.

Principal (L.S.)

Surety

By

SEAL

END OF SECTION

Issued September 2000

QUALIFICATION OF CORPORATION SIGNATURE
MEETING OF THE BOARD OF DIRECTORS

_____, An Arizona Corporation
(Construction Company)

RESOLVED:

That _____ of this
(name) (office)

corporation, whose signature appears below, is hereby authorized, empowered and directed for and on behalf of this corporation and its corporate name to make and execute bids, offers and contracts binding upon this corporation for supplies and services required or rendered by this corporation in the course of this business in amount, up to:

_____ Dollars (\$_____).

(signature of individual named above)

CERTIFICATE

I hereby certify that I am a duly elected and qualified _____ of
(office)
_____, the above
(Construction Company)

named corporation, that the foregoing is a true and correct copy of a resolution adopted at a special meeting of the Board of Directors of said corporation held on _____, and that the foregoing resolution is in full force and effect and has not been repealed, amended, or canceled.

IN WITNESS WHEREOF I have hereunto set my hand and official seal of said corporation.

SEAL

(signature)

(typed name)

Must be submitted if firm is a corporation.

QUALIFICATION OF LIMITED LIABILITY COMPANY SIGNATURE
MEETING OF THE MEMBERS

_____, An Arizona Limited Liability Company
(Construction Company)

RESOLVED:

That _____, a member of this Limited Liability Company,
(name)

whose signature appears below, is hereby authorized, empowered and directed for and on behalf of this Limited Liability Company and its company name to make and execute bids, offers and contracts binding upon this company for supplies and services required or rendered by this company in the course of this business in amount, up to:

_____ Dollars (\$_____).

(signature of member named above)

CERTIFICATE

I hereby certify that I am a duly qualified member of _____, the above named Limited Liability Company, that management of this Limited Liability Company is reserved to its _____ by the Articles of Organization which have not since been amended, that the foregoing is a true and correct copy of a resolution adopted at a special meeting of the members of said Limited Liability Company held on _____, and that the foregoing resolution is in full force and effect and has not been repealed, amended, or canceled.

IN WITNESS WHEREOF I have hereunto set my hand as an authorized member of said Limited Liability Company.

(signature)

(typed name)

Must be submitted if firm is a Limited Liability Company

ARIZONA BOARD OF REGENTS

PERFORMANCE BOND

Pursuant to Board of Regents Policy 3-804E
(Penalty of this bond must be 100% of the contract amount.)

KNOW ALL MEN BY THESE PRESENTS:

THAT, (hereinafter called Principal), as Principal, and (hereinafter called the Surety), as Surety, are held and firmly bound unto the Arizona Board of Regents, (hereinafter called the Obligee) in the amount of (Dollars) (\$) for the payment whereof, the said Principal and Surety bind themselves, and their heirs, administrators, executors, successors and assigns, jointly and severally, firmly by these presents.

WHEREAS, the Principal has entered into a certain written contract with the Obligee, dated the day of , 20, to construct and complete a certain work described as which contract is hereby referred to and made a part hereof as fully and to the same extent as if copied at length herein.

NOW, THEREFORE, THE CONDITION OF THIS OBLIGATION IS SUCH, that if the said Principal shall faithfully perform and fulfill all the undertakings, covenants, terms, conditions and agreements of said contract during the original term of said contract and any extension thereof, with or without notice to the Surety and during the life of any guaranty required under the contract, and shall also perform and fulfill all the undertakings, covenants, terms, conditions, and agreements of any and all duly authorized modifications of said contract that may hereafter be made, notice of which modifications to the Surety being hereby waived; then the above obligation shall be void, otherwise to remain in full force and effect.

PROVIDED, HOWEVER, that this bond is executed pursuant to the provisions of Arizona Board of Regents Policy 3-804E, and all liabilities on this bond shall be determined in accordance with provisions of this section, to the extent as if copied at length herein.

The prevailing party in a suit on this bond, including any appeal thereof, shall recover as a part of his judgment such reasonable attorneys' fees as may be fixed by a judge of the Court.

Witness our hands this day of , 20.

Principal Seal
By
Print Name

Surety Seal
By
Print Name
Address
Telephone #

ARIZONA BOARD OF REGENTS

PAYMENT BOND

Pursuant to Board of Regents Policy 3-804E
(Penalty of this bond must be 100% of the contract amount)

KNOW ALL MEN BY THESE PRESENTS:

THAT, _____
(hereinafter called Principal), as Principal, and _____
_____, a corporation organized and existing under the laws of the State of
_____, with its principal office in the City of _____, (hereinafter called the Surety),
as Surety, are held and firmly bound unto the Arizona Board of Regents, (hereinafter called the Obligee) in the amount of
_____(Dollars)
(\$ _____) for the payment whereof, the said Principal and Surety bind themselves, and their heirs,
administrators, executors, successors and assigns, jointly and severally, firmly by these presents.

WHEREAS, the Principal has entered into a certain written contract with the Obligee, dated the ____ day of
_____, 20____, to construct and complete a certain work described as

which contract is hereby referred to and made a part hereof as fully and to the same extent as if copied at length herein.

NOW, THEREFORE, THE CONDITION OF THIS OBLIGATION IS SUCH, that if the said Principal shall
promptly pay all monies due to all persons supplying labor or materials to him or his subcontractors in the prosecution of
the work provided for in said contract, then this obligation shall be void, otherwise to remain in full force and effect.

PROVIDED, HOWEVER, that this bond is executed pursuant to the provisions of Arizona Board of Regents
Policy 3-804E, and all liabilities on this bond shall be determined in accordance with the provisions of this section, to the
same extent as if copied at length herein.

The prevailing party in a suit on this bond, including any appeal thereof, shall recover as a part of this judgment
such reasonable attorneys' fees as may be fixed by a judge of the Court.

Witness our hands this ____ day of _____, 20_____.

Principal _____ Seal
By _____
Print Name _____

Surety _____ Seal
By _____
Print Name _____
Address _____

Telephone # _____

ARIZONA BOARD OF REGENTS

**PERFORMANCE BOND
FOR SUBCONTRACTS**

Pursuant to Board of Regents Policy 3-804E
(Penalty of this bond must be 100% of the subcontract amount.)

KNOW ALL ME BY THESE PRESENTS:

THAT, _____
(hereinafter called Principal), as Principal, and _____
_____, a corporation organized and existing under the laws of the State
of _____ with its principal office in the City of _____, (hereinafter
called the Surety), as Surety, are held and firmly bound unto _____
_____, (General Contractor) and the Arizona Board of Regents, (hereinafter called
the Obligees) in the amount of _____
(Dollars) (\$ _____) for the payment whereof, the said Principal and Surety bind
themselves, and their heirs, administrators, executors, successors and assigns, jointly and severally,
firmly by these presents.

WHEREAS, the Principal has entered into a certain written subcontract with the General
Contractor, dated the _____ day of _____, 20____, to construct and complete
certain work described as the _____ work for The University of
Arizona Project Number _____, known as _____,
which subcontract is hereby referred to and made a part hereof as fully and to the same extent as if
copied at length herein.

NOW, THEREFORE, THE CONDITION OF THIS OBLIGATION IS SUCH, that if the said
Principal shall faithfully perform and fulfill all the undertakings, covenants, terms, conditions and
agreements of said subcontract during the original term of said subcontract and any extension
thereof, with or without notice to the Surety and during the life of any guaranty required under the
subcontract, and shall also perform and fulfill all the undertakings, covenants, terms, conditions, and
agreements of any and all duly authorized modifications of said subcontract that may hereafter be
made, notice of which modifications to the Surety being hereby waived; then the above obligation
shall be void, otherwise to remain in full force and effect.

PROVIDED, HOWEVER, that this bond is executed pursuant to the provisions of the Arizona
Board of Regents Policy 3-804E, and all Liabilities on this bond shall be determined in accordance
with provisions of this section, to the extent as if copied at length herein.

The prevailing party in a suit on this bond, including any appeal thereof, shall recover as a
part of his judgment such reasonable attorneys' fees as may be fixed by a judge of the Court.

Witness our hands this _____ day of _____, 20____.

PRINCIPAL
By _____
Print Name _____
Address _____

Telephone # _____
Seal

SURETY
By _____
Print Name _____
Address _____

Telephone # _____
Seal

Issued September 2000

The following provisions shall be considered part of **[the General Conditions of the Construction Agreement] [the designated Contract Documents]**.

(Example:

The following provisions shall be considered part of the General Conditions of the Construction Agreement.

1 CONFIDENTIALITY

- 1.1. The Contractor warrants and represents that the Contractor shall not knowingly or negligently communicate or disclose at any time to any person or entity any information in connection with the Work or the Project, except: (1) with prior written consent of the Owner, (2) information that was in the public domain prior to the date of this Agreement, (3) information which becomes part of the public domain by publication or otherwise not due to any unauthorized act or omission of the Contractor, or (4) as may be required to perform the Work or by any applicable law.**
- 1.2. The Contractor, at any time upon the request of the Owner, shall immediately return and surrender to the Owner all copies of any materials, records, notices, memoranda, recordings, drawings, specifications and mock-ups and any other documents furnished by the Owner or the Architect to the Contractor.**
- 1.3.**
- 1.4. The Contractor shall specifically cause all Subcontractors or any other person or entity performing any services, or furnishing any materials or equipment, for the Work to warrant and represent all items set forth in this Section 41.**
- 1.5.**
- 1.6. The representations and warranties contained in this Section 41 shall survive the complete performance of the Work or earlier termination of this Agreement.)**

END OF SECTION

Issued March 2007

DIVISION 0

Section 00860

UA No.

SCHEDULE OF DRAWINGS

Sheet No.

Sheet Title

Division 00

UA No.

Section 00900

Addendum Number [____]

DATE: [_____]

PROJECT: [_____]

[_____]

PROJECT NUMBER: [_____]

OWNER: [_____]

[_____]

[ARCHITECT]: [_____]

[ENGINEER]: [_____]

TO: **[All Prospective Bidders]** [_____]

Issued February 1996

Division 00

UA No.

Section 00900

Addendum Number [____]

This Addendum forms a part of the Contract Documents and modifies the Bidding Documents dated [____], **Addendum Number [1] [____] issued [____]**, and **Addendum Number [2] [____] issued [____]**, with amendments and additions noted below.

Acknowledge receipt of this Addendum in the space provided in the Bid Form. [____.] Failure to do so may disqualify the Bidder.

This Addendum consists of [____] pages and the following Drawings:

No.	Drawing Title	Issue Date
[____]	[_____]	[_____]
[____]	[_____]	[_____]
[____]	[_____]	[_____]
[____]	[_____]	[_____]

CHANGES TO ADDENDUM NUMBER 1 - Issued July 6, 1994

1. Revise Item #3, bid closing date and time to July 31, 1994, 2:00 pm Central Standard time.

CHANGES TO THE PROJECT MANUAL

TABLE OF CONTENTS

2. Delete "Section 09686 - Carpeting with Cushion" from the listing.

DOCUMENT 00100 - INSTRUCTIONS TO BIDDERS

3. Article 2.1 Paragraph C:

Issued February 1996

Division 00

UA No.

Section 00900

Addendum Number [____]

Add to the end of the sentence: ". . . to the offices of the Architect."

SECTION 01019 - CONTRACT CONSIDERATIONS

4. Article 1.3 Paragraph F: Add the following Subparagraph:

4. Section 09688 - Carpeting - Glue Down: Allow the stipulated sum of \$26.75 per sq yd (sq m) for carpet purchase, delivery to site, unloading, and temporary protected storage.

SECTION 09686 - CARPETING WITH CUSHION

5. Delete this section in its entirety.

SECTION 10800 - TOILET AND BATH ACCESSORIES

6. Add the following Acceptable Manufacturers:
Ace Distributors
Forman Manufacturing, Inc.

CHANGES TO THE DRAWINGS

DRAWING A1 - SITE PLAN

7. Revise dimension between the main building and the Boiler House from 30' - 0" (9.1 m) to 36' - 9" (11.2 m).
8. To the List of Drawings add: "L1 - Landscaping Plan".

DRAWING S4 - JOIST FRAMING PLAN

9. Delete this Drawing and replace with Drawing S4a issued with this Addendum.

DRAWING L1 - LANDSCAPING PLAN

10. Include this new Drawing issued with this Addendum in the list of Contract Documents.

APPROVAL OF ADDITIONAL PRODUCTS/SYSTEMS

Section #	Acceptable Manufacturer(s)
-----------	----------------------------

Issued February 1996

Division 00

UA No.

Section 00900

Addendum Number [____]

11. 03300

Acme Admixtures, Inc.

END OF ADDENDUM NUMBER [____]

Issued February 1996

Section 01010

SUMMARY OF WORK

1 PART 1 GENERAL

1.1 SECTION INCLUDES

- A. Contract Description.
- B. Work by Owner.
- C. Owner supplied Products.
- D. Contractor use of site **[and premises]**.
- E. Work Sequence.
- F. Owner occupancy.

1.2 CONTRACT DESCRIPTION

- A. Contract Type: Stipulated Price as described in the Standard Form Agreement Between Owner and Contractor **[(Construction Management Edition)]**.
- A. Contract Type: The University of Arizona® Standard Form Agreement Between Owner and CM@Risk on the Basis of a Guaranteed Maximum Price including issued Addenda.
- B. The work to be performed includes, but is not limited to the following:
 - 1. **[**insert short outline description**]**
 - 2. All other work shown on the drawings and/or miscellaneous incidental work not shown that may be required to complete the project.
- C. Documents Furnished To The Contractor:
 - 1. Owner will furnish the General Contractor **[fifteen (15)]** [_____] sets of drawings and specifications for use in construction of the project. Any additional sets required by the Contractor may be purchased from the Owner.

1.3 WORK BY THE OWNER

- A. Other Contractors, Vendors, and/or forces of the Owner will be working at **[Project Name]** during the construction period and during the Contractor's work on punch list items following substantial completion**[s]**. The areas of other work include, but are not limited to **[furniture installation], [art installation], [lab equipment installation]**.
 - 1. The sequencing of [_____] installation shall be coordinated between the Owner, the Contractor, and the **[Vendor] [Contractor] [UA Forces]**.

Section 01010

SUMMARY OF WORK

- A. The Owner **[has awarded] [will award] [a contract] [contracts]** for **[supply] [and] [installation]** of **[_____]** which **[commences] [will commence on] [_____]**.
- B. Work under **[this contract] [these contracts] [will include:] [includes:]**
- Existing Building Demolition: *The Owner has contracted for demolition of the existing garage structure on site and removal of its foundations. The site will be backfilled at the removed foundations and filled to existing grade elevation. Work will be completed on July 1, 1994.*
 - Elevators: The Owner intends to award a separate contract for elevator work associated with this contract. The proposed elevator contract documents are available for inspection at the office of the Owner.
- C. Items noted NIC (Not in Contract), **[movable cabinets,] [furnishings,] [minor equipment,] [and] [_____]** will be supplied and installed by Owner **[beginning] [before] [after] [_____]**.
- D. Owner will remove and retain possession of the following items before start of work:
- [_____]**.
 - [_____]**.
- E. Contractor shall remove and Owner will take possession of **[the following items:] [items indicated.]**
- [_____]**.
 - [_____]**.

1.4 OWNER SUPPLIED PRODUCTS

- A. Owner's Responsibilities:
- Arrange for and deliver review Shop Drawings, Product Data, and Samples to Contractor.
 - Arrange and pay for Product delivery to site.
 - On delivery, inspect Products jointly with Contractor.
 - Submit claims for transportation damage and replace damaged, defective, or deficient items.
 - Arrange for manufacturers; warranties, inspections, and service.

Section 01010

SUMMARY OF WORK

B. Contractor's Responsibilities:

1. Review Owner furnished Shop Drawings, Product Data, and Samples.
2. Receive and unload Products at site: inspect for completeness or damage jointly with Owner.
3. Handle, store, install, and finish Products.
4. Repair or replace items damaged after receipt.

C. Products supplied to site and installed by Owner.

1. [_____].
2. [_____].

D. Items supplied by Owner for installation by Contractor.

1. [_____].
2. [_____].

1.5 CONTRACTOR USE OF SITE **[AND PREMISES]**.

A. Limit use of site **[and premises]** to allow:

1. Owner occupancy.
2. **[Work by Others] [and] [Work by Owner]/**
3. Use of site **[and premises]** by **[the public.] [_____].]**
4. In addition to site utilization limitations and requirements shown on drawings, and other contract documents, Contractor shall administer allocation of available space equitably among entities needing access and space, so as to produce the best overall efficiency in performance of total work on project. Contractor shall schedule deliveries as so to minimize space and time requirements for storage of materials and equipment on site. Use of the site, other than as specified in the Contract Documents, shall be requested in writing for the Owner's review and approval.

B. Access to Site: **[Limited to [_____].] [_____].]**

C. Emergency Building Exits During Construction: **[Limited to [_____]. [_____].]**

Section 01010

SUMMARY OF WORK

D. Construction Operations: **[Limited to [areas noted on Drawings] [_____].]**
[_____].]

1. Protect all existing work from damage. All damaged work shall be replaced or repaired a no cost to the Owner and to the satisfaction of the Owner or the Authority having jurisdiction thereover.

E. Time Restrictions for Performing Work:

1. No work shall be performed before **[7:00 a.m.]** and after **[5:00 p.m.]**, Monday through Friday, except with approval of the Owner. Hot weather concrete work and other critical work may require work between **[5:00 p.m.]** and **[7:00 .am.]** in which event the Contractor shall, in advance, coordinate time and obtain the prior written approval of Owner for such work.

2. Night Work:

- a. In general, all work shall be performed during regulated daytime hours. Night work hours shall be defined as 6 p.m. to 6 a.m. Approval for night work must be obtained in writing from the Owner.
- b. If night work is allowed, the Contractor shall furnish, erect and maintain an amount of artificial lighting sufficient for the construction, flagging, inspection, etc., and for the safety of the workmen and the general public. Lighting shall be directed downward towards the construction site and away from the adjacent residential area to the greatest extend possible. Refer to requirements in Section 01510. No night work shall be performed until the Construction Project Manager is satisfied that an adequate amount of artificial light has been furnished and placed properly.
- c. When doing night work, deactivation of the vehicle back-up devices will be required. When vehicle back-up alarm devices are deactivated, the Contractor shall provide flag personnel to direct traffic at all times in order to comply with OSHA requirements.
- d. Every effort shall be made to minimize noise and disruptions during all night work activities.

3. In addition to the above provision, Contractor must restrict work activities during certain critical periods of Owner's operations. These time periods and application restrictions are as follows:

[incorporate UA schedule with desired restrictions**]**

4. On any project located adjacent to (within 150 feet) non-University residential areas, all applicable City of Tucson ordinances concerning nuisance abatement shall be observed by the Contractor. These ordinances shall apply to all work under this Contract whether or not they are applicable to said work as enacted. Where there are variations between the Owner's regulations and applicable City ordinances, the more restrictive shall be observed.
5. In addition to all the above provisions, Owner reserves the right to restrict Contractor's work activity as may be necessary proper and uninterrupted

Section 01010

SUMMARY OF WORK

operation of Owner's facilities. Owner will attempt to coordinate Contractor's schedule with Owner's schedule of activities so as to minimize any unscheduled restrictions of Contractor's work.

F. Utilities Outages and Shutdowns

1. The Contractor shall perform the work under this Contract with a minimum of outage time for all utilities. Coordinate all interruptions with the Owner. Interruption shall be by approved section of the utility. In some cases, the Contractor may be required to perform the work while the existing utility is in service. When it is necessary to interrupt the existing utilities, the Contractor shall notify the Architect and the Owner in writing at least two weeks in advance of the time the existing service is to be interrupted. Depending upon the activities at the facility which require continuous service from the existing utility, an interruption may not be subject to schedule at the time desired by the Contractor. In such cases the interruption may have to be scheduled at a time of minimum requirement of demand from the utility. The amount of time requested by the Contractor for interruption of existing utility services shall be as approved by the Owner. Service interruptions may occur outside regular working hours without any additional expense to the Owner.

G. Hot Work Permit;

1. Hot work is defined as cutting, welding, soldering, sweating, brazing, and other similar activities conducted with portable gas or arc equipment.
2. Hot work permits are required for demolition, structural, mechanical, and general hot work activities, in new and existing buildings (including utility tunnels and vaults).
3. Hot work permits must be obtained by each individual entity performing hot work on a project. More than one permit may be required for each project. A separate permit is required for each building where hot work is being conducted when a particular project includes multiple buildings.
4. Secure permits prior to the commencement of any on-site hot work from the Owner's Department of Risk Management and Safety, 220 West Sixth Street, Fourth Floor, 621-1790. Detailed procedures for obtaining and complying with the hot work permit (including validity periods and renewal requirements) will be issued with the actual permit.
5. All permits must be turned in to Owner upon expiration.

H. Safety

1. The Contractor shall comply with the Williams-Steiger Occupational Safety and Health Act of 1970 and shall submit a written statement to Architect that he will do so.

Section 01010

SUMMARY OF WORK

2. Contractor shall maintain adequate emergency exiting at all times for construction area and areas adjacent to the construction area while work is being completed.

1.6 WORK SEQUENCE

- A. Construction Work in **[phase] [to accommodate Owner's occupancy requirements] [_____]** during the construction period, coordinate construction schedule and operations with **[Owner:] [Architecture/Engineer:]**
 1. **[Phase] 1:** [_____].
 2. **[Phase] 2:** [_____].
 3. **[Phase] 3:** [_____].

1.7 OWNER OCCUPANCY

- A. The Owner intends to occupy the [_____] portion of the Project by [_____].

- A. The Owner will occupy the **[site] [premises] [_____]** during **[the entire period of construction.] [[Stage] [Phase] of construction.] [for the conduct of normal operations.] [for installation of [_____].]**
- B. Cooperate with Owner to minimize conflict, and to facilitate Owner's operations.
- C. Schedule the Work to accommodate Owner occupancy.

2 PART 2 PRODUCTS

Not Used.

3 PART 3 EXECUTION

Not Used.

END OF SECTION

Section 01019

CONTRACT CONSIDERATIONS

1 PART 1 GENERAL

1.1 SECTION INCLUDES

- A. Allowances.
- B. Schedule of Values.
- C. Application for payment.
- D. Change procedures.
- E. Defect Assessment.
- F. Measurement and payment – unit prices.
- G. Optional Prices.

1.2 RELATED SECTIONS

- A. Section 01027 – Application For Payment.
- B. Section 01028 – Modification Requirements.
- C. Section 01030 – Optional Prices.
- D. Section 01600 – Material and Equipment: Product substitutions.

1.3 ALLOWANCES

- A. Costs Included in Allowances: Cost of Product to Contractor or Subcontractor, less applicable trade discounts; **[delivery to site] [and] [applicable taxes]** [_____]. Subcontractor, less applicable trade discounts; **[delivery to site] [and] [applicable taxes]** [_____].
- B. Costs Not Included in Allowances but Included in the Contract Sum: Product **[delivery to site and] handling at site, including unloading, uncrating, and storage; [protection of Products from elements and from damage;] [and] [labor for installation and finishing;]** [_____].
- C. **[Architect/Engineer] [Construction Manager]** Responsibilities:
 - 1. Consult with Contractor for consideration and selection of Products, **[suppliers] [and] [installers]**.
 - 2. Select Products in consultation with Owner and transmit decision to Contractor.

Section 01019

CONTRACT CONSIDERATIONS

3. Prepare Change Order.
- D. Contractor Responsibilities:
1. Assist **[Architect/Engineer] [and Construction Manager]** in selection of Products, suppliers **[and installers]**.
 2. Obtain proposals from suppliers **[and installers]**. and offer recommendations.
 3. On notification of selection by **[Architect/Engineer] [Construction Manager] [Owner]** execute purchase agreement with designated supplier **[and installer]**.
 4. Arrange for and process shop drawings, product data, and samples. Arrange for delivery.
 5. Promptly inspect Products upon delivery for completeness, damage, and defects. Submit claims for transportation damage.
- E. Differences in costs will be adjusted by Change Order.
- F. Allowances Schedule:
1. Section [_____]: Include the stipulated sum of \$[_____] for purchase and delivery of [_____].
 2. Section [_____]: Include the stipulated sum of \$[_____] for installation of [_____].
 3. Section [_____]: Include the stipulated sum of \$[_____] for purchase, delivery, and installation of [_____].
 4. Section [_____]: Include the unit price of \$[_____] per [_____] for purchase, delivery, and installation of [_____].
 5. **Section 01312 – Cost Loaded Construction Progress Schedules (Third Party Scheduler): Included the stipulated sum of \$[_____] for Contractor’s share of the cost of the Third Party Scheduler.**

1.4 SCHEDULE OF VALUES

- A. Submit a printed schedule on AIA Form G702 and G703 – Application and Certification for Payment Continuation Sheet. Contractor’s electronic media printout of this form will also be considered.
- B. Submit Schedule of Values in duplicate within **[15] [20] [_____]** days after date established in Notice to Proceed.

Section 01019

CONTRACT CONSIDERATIONS

- C. Format: **[Utilize the Table of Contents of this Project Manual. Identify each line with number and title of the major specification Section.] [Identify [site mobilization,] [bonds and insurance.] [_____].]**

**** OR ****

- D. Submit a Schedule of Values for review by the Owner's Representative. The Schedule of Values shall be based on the breakdown of the computer listing of activities. The Schedule of Values produced for the Cost-Loaded Construction Progress Schedule specified in Section **[01311] [01312]** shall allocate a dollar Value (cost), an estimate of manpower, and crew size for each activity of the Construction CPM Network. Activity costs, summed by responsibility, shall equal the actual subcontract price, or cost to the Contractor for work it is to perform. Bonds and insurance for which payment is made in full at the commencement of the project shall be a separate line item. The cost breakdown shall also indicate preparation and delivery of operations and maintenance manuals, record documents, and punch lists as separate line items. The sum of all activity costs shall equal the total Contract Sum. Each activity cost shall be coded with a cost code corresponding to the subcontractor responsible for performing the work so that subtotals for each division of the work can be prepared.
- E. Include as separate line items, the amount of each Allowance specified in this section. **[For unit cost Allowances, identify quantities taken from Contract Documents multiplied by the unit cost to achieve the total for the item.]**

****OR****

- F. Within **[seven (7)] [_____]** calendar days following receipt of the final cost-loaded schedule, Contractor shall participate in a conference with the Owner's Representative, **[Architect] [and the Third Party Scheduler]** to review and evaluate the Schedule of Values. The accepted Schedule of Values shall, in the best judgment of the Contractor, Owner's Representative, **[Architect] [and the Third Party Scheduler]**, represent a fair, reasonable, and equitable dollar cost and manpower allocation for each activity in the cost-loaded construction schedule.
- G. **[Include within each line item a direct proportional amount of Contractor's overhead and profit.] [_____].**
- H. Submit revised schedule listing approved Change Orders with each Application For Payment.

1.5 APPLICATIONS FOR PAYMENT

- A. Submit **[three] [_____]** copies of each application on **Application and Certificate for Payment and AIA G703 – Continuation Sheet.] [AIA G722 – Project Application and Project Certificate for Payment and AIA G723 – Project Application Summary.]** Contractor's electronic media printout of this form will also be considered.

Section 01019

CONTRACT CONSIDERATIONS

- B. Content and Format: Utilize current approved Schedule of Values for listing items in Application for Payment.
- C. Payment Period: **[Monthly]**.
- D. Waiver of **[Claims]**.
- E. Include Vendor Claim Forms and other forms required by Owner.
- F. Include an updated construction progress schedule.
- G. Payment for stored materials and equipment will be restricted by Owner to custom fabricated materials identified with mark numbers on shop or erection drawings, and to equipment specified with tag numbers in the Contract Documents.
- H. Payment for bulk materials which are normally stocked by suppliers will be made by Owner only when such materials have been physically incorporated into the Work.
- I. Materials Stored Offsite: Submit all requests for off-site storage to the Owner for consideration and approval. Options and requirements for off-site storage include, but may not be limited to:
 - 1. Possibility of off-site Owner property on which adequately secured storage can be made available during the contract period, at rental rates as set by the Owner; or the availability of an Owner approved bonded warehouse or secured bonded site.
 - 2. Provision by the Contractor, at no cost to the Owner, of off-site storage on non-University property with insurance (naming the Owner as additional insured) and bonding to hold the Owner free of all risks, including delay attributed to loss, damage or destruction of stored materials off job site.
 - (a) Bonding shall protect the Owner's exclusive right of possession, and indemnify the Owner against any loss of use or possession of materials paid for by the Owner and not stored on University property.
 - 3. Contractor shall provide suitable security fence/materials enclosure for locked containment of materials submitted for payment.
 - 4. Contract shall bear all costs for inspection of quantities at time of storage, and monthly thereafter if the list of materials changes.
 - 5. Contractor shall bear all costs for security monitoring of the storage site as deemed required by the Owner.
 - 6. All Payment Applications for stored materials billed must be accompanied by a Bill of Sale, indicating transfer of ownership of such materials to the Owner.

Submit all requests for off-site storage to Owner for consideration. Materials stored off-site on non-University property must be bonded and insured, adequately secured. Owner must be named as additional insured for all stored materials. Any and all costs of inspection of quantities

Section 01019

CONTRACT CONSIDERATIONS

at time of storage and/or for security monitoring of the storage site (if required) shall be borne by the Contractor.

1.6 CHANGE PROCEDURES

- A. The **[Architect/Engineer]** will advise of minor changes in the Work not involving an adjustment to Contract Sum or Contract Time by issuing a written order.
- B. The **[Architect/Engineer] [Construction Manager] [Owner]** may issue a Proposal Request which includes a detailed description of a proposed change with supplementary or revised drawings and specifications, a request for any change in Contract Time for executing the change **[and] [the period of time during which the requested price will be considered valid]**. Contractor shall prepare and submit an estimate within the number of days stated in the Proposal Request.
- C. The Contractor may propose changes by submitting a request for change to the **[Architect/Engineer], [Construction Manager], [Owner]**, describing the proposed change and its full effect on the Work. Include a statement describing the reason for the change, and the effect on the Contract Sum and Contract Time with full documentation **[and a statement describing the effect on Work by separate or other Contractors]**. **[Document any requested substitutions in accordance with Section [01600.] [_____].]**
- D. Stipulated Sum Change Order: Based on **[Proposal Request] [Notice of Change]** and Contractor's **[fixed] [estimated] [maximum]** price quotation **[or Contractor's request for a Change Order as approved by [Architect/Engineer] [Construction Manager] [Owner].]**
- E. Unit Price Change Order: For contract unit prices and quantities, the Change Order will be executed on a fixed unit price basis. For unit costs or quantities of units of work which are not pre-determined, execute Work under a Work Directive issued by **[Owner] [Architect] [Engineer] [Construction Manager]** and changes in the Contract Sum will be computed in accordance with **[Section 28] [Section 10]** of the General Conditions.
- F. **[Architect/Engineer] [Construction Manager] [Owner]** may issue a written directive, instructing the Contractor to proceed with a change in the Work, for subsequent inclusion in a Change Order. Document will describe changes in the Work, and designate method of determining any change in Contract Sum or Contract Time. Promptly execute the change.
- G. Cost Basis Change Order: Submit itemized account and supporting data after completion of change, within time limits indicated in the Conditions of the Contract. **[Architect/Engineer] [Construction Manager] [Owner]** will determine the change allowable in Contract Sum and Contract Time as provided in the Contract Documents.

Section 01019

CONTRACT CONSIDERATIONS

- H. Maintain detailed records of work done on cost basis. Provide full information required for evaluation of proposed changes, and to substantiate costs for changes in the Work.
- I. Change Order Forms: **[AIA G701]** **[AIA G701/CM]** Change Order.
- J. Execution of Change Orders: **[Architect/Engineer]** **[Construction Manager]** **[Owner]** will issue Change Orders for signatures of parties as provided in the Conditions of the Contract.

1.7 DEFECT ASSESSMENT

- A. Replace the Work, or portions of the Work, not conforming to specified requirements.
- B. If, in the opinion of the **[Architect/Engineer]** **[Construction Manager]** **[Owner]** **[_____]**, it is not practical to remove and replace the Work, the **[Architect/Engineer]** **[Construction Manager]** **[Owner]** **[_____]** will direct an appropriate remedy or adjust payment.

1.8 MEASUREMENT AND PAYMENT – UNIT PRICES

- A. Authority: Measurement methods are delineated in the individual specification sections.
- B. Take measurements and compute quantities. The **[Architect/Engineer]** **[Construction Manager]** **[Owner]** **[_____]** will verify measurements and quantities.

****OR****

- B. The **[Architect/Engineer]** **[Construction Manager]** **[Owner]** will take measurements and compute quantities accordingly. Provide and assist in the taking of measurements.
- C. Unit Quantities: Quantities and measurements indicated in the **[Bid Form]** **[_____]** are for contract purposes only. **[Quantities and measurements supplied or placed in the Work shall determine payment.]** **[Actual quantities provided shall determine payment.]**
- D. Payment Includes: Full Compensation for required labor, Products, tools, equipment, plant and facilities, transportation, services and incidentals; erection, application or installation of an item of the Work; overhead and profit.
- E. Unit Price Schedule:
 - 1. **[Item: [_____]; Section [_____].]**

Section 01019

CONTRACT CONSIDERATIONS

2. **[Item: [_____]; Section [_____].]**

3. **[Item: [_____]; Section [_____].]**

1.9 OPTIONAL PRICES

A. Accepted Options will be identified in Owner-Contractor Agreement.

B. Coordinate related work and modify surrounding work as required.

C. Schedule of Optional Prices:

1. Optional Price No. 1: **[Foundation Wall Construction:**

Based Bid Item: Sections 03100, 03200, and 03300 (Cast-In-Place Concrete including pre-molded control joints) and Drawing numbers A-3 and S-2 including referenced details.

Optional Price No. 1: Sections 04100 and 04310 (mortar and masonry including integral reinforcement) and Drawing numbers A-3-a and S-2-a including referenced details.]

2. Optional Price No. 2 **[Title]:**

Base Bid item: Section [_____] and Drawing number { _____ } including [_____].

Optional Price No. 2: Section [_____] and Drawing number [_____] including { _____ }.

3. Optional Price No. 3: **[Title]:**

Base Bid Item: Section [_____] and Drawing number [_____] including [_____].

Optional Price No. 3: Section [_____] and Drawing number [_____] including [_____].

2 PART 2 PRODUCTS

Not Used.

3 PART 3 EXECUTION

Not Used.

DIVISION 1

UA No.

Section 01019

CONTRACT CONSIDERATIONS

END OF SECTION

Section 01027

APPLICATIONS FOR PAYMENT

1 PART 1 GENERAL

1.1 SECTION INCLUDES

- A. Format
- B. Preparation of Applications
- C. Submittal Procedures
- D. Substantiating Data
- E. Materials Stored Offsite

1.2 RELATED SECTIONS

- A. Section 01019 – Contract Considerations.
- B. Section 01028 – Modification Requirements.
- C. Section 01019 – Contract Considerations.
- D. Section 01300 – Submittals.
- E. Section 01700 – Contract Closeout.

1.3 FORMAT

- A. **[AIA G702 – Application and Certificate for Payment and AIA G703 – Continuation Sheet] [AIA G722 – Project Application and Project Certificate for Payment and AIA G723 – Project Application Summary] [Contractor’s electronic media driven form] [_____]** including continuation when required.
- B. For each item, provide a column for listing each of the following:
 - 1. Item Number.
 - 2. Description of work.
 - 3. Scheduled Values.
 - 4. Previous Applications.
 - 5. Work in Place **[and Stored Materials]** under this Application.
 - 6. Authorized Change Orders.
 - 7. Total Completed **[and Stored]** to Date of Application.

Section 01027

APPLICATIONS FOR PAYMENT

8. Percentage of Completion.
9. Balance to Finish.
10. Retainage.

1.4 PREPARATION OF APPLICATIONS

- A. General: Unless otherwise indicated, sequence of progress payments shall be regular, and each must be consistent with previous applications and payments. Certain applications will involve extra requirements, including initial application, application at time of substantial completion, and final payment application which is addressed in Section 01700.
- B. Present required information **[in typewritten form.] [or] [on electronic media printout.]**
- C. Execute certification by notarized signature of authorized officer.
- D. Use data from current approved Schedule of Values. Provide dollar value in each column for each line item for portion of work performed **[and for stored Products]**.
- E. Applications for payment of allowance items shall include invoices and/or receipts for documentation of payment amount.
- F. List each authorized Change Order as an extension on AIA G703 – Continuation Sheet, listing Change Order number and dollar amount(s) for each item of Work.
- G. The following submittals must precede submittal of first payment application:
 1. Listing of subcontractors and material vendors **[submitted with the bid]**.
 2. Schedule of Values.
 3. Construction Schedule – See Section **[01300] [01310] [01311]** for specific requirements.
 4. Proposed Products List and Submittal Schedule.
 5. Copies of any required authorizations from governing authorities for current performance of the work.
 6. Performance and Payment Bonds and Certificate(s) of Insurance (submitted to the Owner prior to contract award).
 7. Copies of executed contracts for all subcontractors.
 8. Copies of Performance Bond from required subcontractors.

Section 01027

APPLICATIONS FOR PAYMENT

- H. Following issuance of the final Certificate of Substantial Completion, a "special" payment application may be prepared and submitted. The principal actions and submittals which must precede such special Application for Payment include the following:
1. Any required approvals or certifications by governing authorities and/or franchised services, assuring Owner's full access and use of completed Work.
 2. Warranties, guaranties, maintenance agreements, and similar provisions of Contract Documents.
 3. Test/adjust/balance records, Operation and maintenance instructions, meter readings, start-up performance reports, and similar information for Owner's use.
 4. Consent of Surety for any requested reduction of retainage.
 5. Final progress photographs, when required.
 6. Change-over of door locks and other access to Owner's property.
 7. Complete start-up and testing of systems and instructions for Owner's operating/maintenance personnel. Discontinue or change over and remove from project site temporary facilities and services, along with construction tools and facilities, mock-ups, and similar elements.
 8. Complete final cleaning requirements.
 9. Touch-up and otherwise repair and restore marred exposed finishes.
- I. Prepare Application for Final Payment as specified in Section 01700.

1.5 SUBMITTAL PROCEDURES

- A. Submit **[three]** [_____] copies of each Application for Payment.
- B. Submit an updated [_____] construction schedule with each Application for Payment.
- C. Payment Period: **[Submit at intervals stipulated in the Agreement.]** [_____.]
- D. Submit with transmittal letter as specified for Submittals in Section **[01300.]**
- E. Submit [_____] waivers.

1.6 SUBSTANTIATING DATA

- A. When **[Architect/Engineer]** **[Construction Manager]** or Owner requires substantiating information, submit data justifying dollar amounts in question.

Section 01027

APPLICATIONS FOR PAYMENT

- B. Provide one copy of data with cover letter for each copy of submittal. Show application number and date, and line item by number and description.
- C. Include the following with the application:
 - 1. Current construction photographs specified in Section 01300.
 - 2. Partial release of liens from major subcontractors and vendors.
 - 3. Record documents as specified in Section 01700, for review by the Owner which will be returned to the Contractor.
 - 4. Affidavits and other specified documents attesting to off-site stored products.
 - 5. Construction progress schedules, revised and current as specified in Section **[01300] [01310] [01311] [01312]**.

1.7 MATERIALS STORED OFFSITE

1 Materials Stored Offsite:

Submit all requests for off-site storage to the Owner for consideration and approval. Options and requirements for off-site storage include, but may not be limited to:

- A. Possibility of off-site Owner property on which adequately secured storage can be made available during the contract period, at rental rates as set by the Owner; or the availability of an Owner approved bonded warehouse or secured bonded site.
- B. Provision by the Contractor, at no cost to the Owner, of off-site storage on non-University property with insurance naming the Owner as additional insured and bonding to hold the Owner free of all risks, including delay attributed to loss, damage or destruction of stored materials off jobsite.
 - 1. Bonding shall protect the Owner's exclusive right of possession and indemnify the Owner against any loss of use or possession of materials paid for by the Owner and not stored on University property.
- C. Contractor shall provide suitable security fence/materials enclosure for locked containment of materials submitted for payment.
- D. Contractor shall bear all costs for inspection of quantities at time of storage, and monthly thereafter if the list of materials changes.
- E. Contractor shall bear all costs for security monitoring of the storage site as deemed required by the Owner.

Section 01027

APPLICATIONS FOR PAYMENT

F. All Payment Applications for stored materials billed must be accompanied by a Bill of Sale, indicating transfer of ownership of such materials to the Owner.

2 PART 2 PRODUCTS

Not Used.

3 PART 3 EXECUTION

Not Used.

END OF SECTION

Section 01028

MODIFICATION REQUIREMENTS

1 PART 1 GENERAL

1.1 SECTION INCLUDES

- A. Submittals.
- B. Documentation of change in Contract Sum and Contract Time.
- C. Change procedures.
- D. Owner Order.
- E. Stipulated Sum change order.
- F. Unit price change order.
- G. Cost Basis change order.
- H. Execution of change orders.
- I. Correlation of Contractor submittals.

1.2 RELATED SECTIONS

- A. Document **[00500 - Agreement]** [_____]
- B. Document **[00700 – General Conditions]** [_____]
- C. Section 01019 – Contract Considerations.
- D. Section [____ -- _____]: Scope of unit prices.
- E. Section 01027 – Applications for Payment:
- F. Section 01300 – Submittals:
- G. Section 01310 – Construction Progress Schedules:
- H. Section 01311 – Cost Loaded Construction Progress Schedules:
- I. Section 01312 – Third Party Scheduler:
- J. Section 01600 – Material and Equipment: Product options and substitutions.
- K. Section 01700 – Contract Closeout: Project record documents.

1.3 SUBMITTALS

Section 01028

MODIFICATION REQUIREMENTS

A. Submit name of the individual authorized to receive change documents and be responsible for informing others in Contractor's employ or Subcontractors of changes to the Work.

B. Change Order Forms: **[AIA G701] [AIA G701/CM]** Change Order.

1.4 DOCUMENTATION OF CHANGE IN CONTRACT SUM AND CONTRACT TIME

A. Maintain detailed records of work done on a cost basis. Provide full information required for evaluation of proposed changes, and to substantiate costs of changes in the Work.

B. Document each quotation for a change in cost or time with sufficient data to allow evaluation of the quotation.

C. Provide data to support computations: (For computation of items 2 and 3, refer to example of Change Order Pricing included at the end of this section).

1. Quantities of products, labor and equipment.
2. Taxes, Insurance, and bonds.
3. Overhead and profit.
4. Justification for any change in Contract Time.
5. Credit for deletions from Contract, similarly documented.

D. Support each claim for additional costs, and for work done on a cost basis, with additional information.

1. Origin and date of claim.
2. Dates and times work was performed, and by whom.
3. Time records and wage rates paid.
4. Invoices and receipts for products, equipment, and subcontracts, similarly documented.

1.5 CHANGE PROCEDURES

A. The Architect/Engineer will advise of minor changes in the Work not involving an adjustment to Contract Sum or Contract Time as authorized by AIA A201, by issuing supplemental instructions on **[AIA Form G710.] [_____].**

B. The **[Architect/Engineer] [Construction Manager] [Owner]** may issue a Proposal Request which includes a detailed description of a proposed change with supplementary or revised Drawings and specifications, **[a change in Contract Time]**

Section 01028

MODIFICATION REQUIREMENTS

for executing the change] [with a stipulation of any overtime work required] [and] [the period of time during which the requested price will be considered valid.]

- C. The Contractor may propose a change by submitting a request for change to the **[Architect/Engineer] [Construction Manager] [Owner]** describing the proposed change and its full effect on the Work, with a statement describing the reason for the change, and the effect on the Contract Sum and Contract Time with full documentation [and a statement describing the effect on Work by separate or other contractors]. [Document any requested substitutions in accordance with Section [01600.] [_____].]

1.6 OWNER DIRECTIVE

- A. The **[Architect/Engineer] [Construction Manager]** may issue a written order, signed by the Owner, instructing the Contractor to proceed with a change in the Work, in accordance with Section **[28.4] [10.2 CM@R]** of the General Conditions, for subsequent inclusion in a Change Order.
- B. The document will describe changes in the Work, and will designate the method of determining any change in Contract Sum or Contract Time.
- C. Promptly execute the change in Work.

1.7 STIPULATED SUM CHANGE ORDER

- A. Based on a **[Proposal Request]** and the Contractor's **[fixed] [estimated] [maximum]** price quotation [or Contractor's request for a Change Order as approved by the [Architect/Engineer] [Construction Manager] [and Owner].

1.8 UNIT PRICE CHANGE ORDER

- A. For pre-determined unit prices and quantities, the Change Order will be executed on a fixed unit price basis.
- B. For unit costs or quantities of units of work which are not pre-determined, execute Work under a written order from Owner.
- C. Changes in Contract Sum or Contract Time will be computed as specified for a Cost Basis Change Order.

1.9 COST BASIS CHANGE ORDER

- A. Submit itemized account and supporting data after completion of change, within time limits indicated in the Conditions of the Contract.
- B. The **[Architect/Engineer] [Construction Manager] [Owner]** will determine the change allowable in Contract Sum and Contract Time as provided in the Contract Documents.

Section 01028

MODIFICATION REQUIREMENTS

- C. Maintain detailed records of work done on cost basis.
- D. Provide full information required for evaluation of proposed changes, and to substantiate costs for changes in the Work.

1.10 EXECUTION OF CHANGE ORDERS

- A. Execution of Change Orders: The [Architect/Engineer] [Construction Manager] [Owner] will issue Change Orders for signatures of parties as provided in the Conditions of the Contract.

1.11 CORRELATION OF CONTRACTOR SUBMITTALS

- A. Promptly revise Schedule of Values and Application for Payment forms to record each authorized Change Order as separate line items and adjust the Contract Sum.
- B. Promptly revise progress schedules to reflect any change in Contract Time, revise sub-schedules to adjust times for other items of work affected by the change, and resubmit.
- C. Promptly enter changes in Project Record Documents.

2 PART 2 PRODUCTS

Not Used

3 PART 3 EXECUTION

Not Used

END OF SECTION

Section 01030

OPTIONAL PRICES

1 PART 1 GENERAL

1.1 SECTION INCLUDES

- A. Submission requirements.
- B. Schedule of Options.

1.2 RELATED SECTIONS

- A. Document **[00500] [00500CM Agreement:]** Incorporating monetary value of accepted Options.
- B. Document 00100 – **[Instruction to Bidders.] [Instructions to CM@Risk.]**
- C. Section 01019 – Contract Considerations.
- D. Section 01300 – Submittals.
- E. Section 01600 – Material and Equipment: Product options and substitutions.

1.3 SUBMISSION REQUIREMENTS

- A. As set forth in the Instructions to **[Bidders] [CM@Risk]** the amount quoted for each *Optional Price* is to include the *furnishing of all materials, plant, equipment, tools and all other facilities called for in the Contract Documents, and the performance of all labor and services necessary and proper for the completion of the Option(s) except such as may be otherwise expressly provided in the Contract Documents.*
- B. Options quoted **[on Bid Forms] [in the GMP]** will be reviewed and accepted or rejected at the Owner's option. Accepted options will be identified in the Owner-Contractor Agreement.
- C. Coordinate related work and modify surrounding work to integrate the Work of each Option.

1.4 SCHEDULE OF OPTIONS

- A. Optional Price No. 1 – *[*Provide a fire sprinkler system.*
 - 1. **This Optional Price is for providing a complete automatic fire sprinkler system installation for the areas shown on the drawings and as described in the Specifications.]*
- B. Optional Price No. 2 – *[*Provide an acid neutralization system.*

DIVISION 1

UA No.

Section 01030

OPTIONAL PRICES

1. **This Optional Price includes installing new concrete curbs and a new drain line connecting the new installation to an existing sewer. Also included is the relocation of two tanks, three steel cover plates, one trap, one sensor, one sink, one eye wash and shower, and one controller from an existing location shown on the drawings. These items to be relocated must be installed as a complete system at the new location as indicated.*]*

2 PART 2 PRODUCTS

Not Used.

3 PART 3 EXECUTION

Not Used

END OF SECTION

Issued October 2003

Section 01039

COORDINATION AND MEETINGS

1 PART 1 GENERAL

1.1 SECTIONS INCLUDES

- A. Coordination and Project Conditions.
- B. Coordination Drawings.
- C. Staff Names.
- D. Field Engineering.
- E. Preconstruction Meeting.
- F. Progress Meetings.
- G. Preinstallation Meetings.

1.2 RELATED SECTIONS

- A. Section 01045 – Cutting and Patching.
- B. Section 01050 – Field Engineering.
- C. Section 01120 – Alteration Project Procedures.

1.3 COORDINATION AND PROJECT CONDITIONS

- A. Coordinate scheduling, submittals, and Work of the various sections of the Project Manual to ensure efficient and orderly sequence of installation of interdependent construction elements, **[with provisions for accommodating items installed later.]**
- B. Verify utility requirements and characteristics of operating equipment are compatible with building utilities. Coordinate work of various sections having interdependent responsibilities for installing, connecting to, and placing in service, such equipment.
- C. The Installer or Subcontractor of each element of the work must examine the conditions of the substrate to receive the work, dimensions and spaces adjacent, tolerances, interfacing with other elements and services, and the conditions under which the work will be performed, and must notify the Contractor in writing of conditions detrimental to the proper or timely completion of the work. If work proceeds the substrate will be deemed acceptable by Installer or Subcontractor. Do not proceed with the work until unsatisfactory conditions have been corrected in a manner acceptable to the Installer.

Section 01039

COORDINATION AND MEETINGS

- D. Coordinate space requirements, supports, and installation of mechanical and electrical Work which are indicated diagrammatically on Drawings. Follow routing shown for pipes, ducts, and conduit, as closely as practicable; place runs parallel with lines of building. Utilize spaces efficiently to maximize accessibility for other installations, for maintenance, and for repairs.
- E. In finished areas **[except as otherwise indicated]**, conceal pipes, ducts, and wiring within the construction. Coordinate locations of fixtures and outlets with finish elements.
- F. Coordinate completion and clean-up of Work of separate sections in preparation for Substantial Completion **[and for portions of Work designated for Owner's [partial] occupancy]**.
- G. After Owner occupancy of premises, coordinate access to site for correction of defective Work and Work not in accordance with Contract Documents, to minimize disruption of Owner's activities.

1.4 COORDINATION DRAWINGS

- A. For locations where several elements of equipment mechanical, electrical or other work must be sequenced and positioned with precision in order to fit into the available space, prepared coordination drawings showing the actual physical dimensions at accurate scale required for the installation. Prepare and submit coordination drawings prior to purchase/fabrication/installation of any of the elements involved in the coordination.
- B. Lay out the work in conformity with the Contract Drawings, coordination drawings and other shop drawings, product data and similar requirements, so that the entire installation will perform as a properly interfaced and integrated system.
- C. Comply with submittal requirements, Section 01300.
- D. The submittal by the Contractor of suitable coordination drawings meeting the above requirements shall be a condition precedent to the Owner making monthly progress payments.

1.5 STAFF NAMES

- A. Within 5 days of Notice of Intent to Award, submit a list of the Contractor's principle staff assignments, including the Project Manager, Superintendent, and other coordinating, administrative and supervisory personnel in attendance at the site. Contractor shall provide relevant work experience data for all assigned personnel to the Owner for review and approval, including authority assignment, addresses, and phone numbers.

1.6 FIELD ENGINEERING

Section 01039

COORDINATION AND MEETINGS

- A. Employ a Land Surveyor registered in the State of Arizona and acceptable to Architect/Engineer.
- B. Contractor confirms and protects survey control and reference points.
- C. Verify set-backs and easements, confirm drawing dimensions and elevations. Prior to commencing work, carefully check existing conditions and compare all drawings that in any way affect the location or elevation of the Work, and immediately report any discrepancy to Architect for verification and adjustments. Any duplication of work made necessary by failure or neglect to comply with this requirement shall be done at Contractor's sole expense.
- D. Provide field engineering services. Establish elevations, lines, and levels, utilizing recognized engineering survey practices. Working from existing or Owner established reference points, establish and maintain bench marks and other dependable markers, and set lines and levels for the work at each story of construction and elsewhere on site as needed to properly locate each element of entire project. Calculate and measure required dimensions as shown within recognized tolerances. Do not scale drawings to determine dimensions. Advise tradesmen performing the work of the marked lines and levels provided for their use in layout of work.
- E. Submit a copy of **[site drawing] [and] certificate** signed by the Land Surveyor certifying that the elevation and locations of the Work are in conformance with the Contract Documents.

1.7 PRECONSTRUCTION MEETING

- A. Owner will schedule a meeting after Notice of Intent to Award has been issued.
- B. Attendance Required: Owner, **[Architect/Engineer,] [Construction Manager] [_____]** and Contractor.
- C. Agenda:
 - 1. Receipt of Construction Agreement Between Owner and Contractor signature (if applicable).
 - 2. Submission of executed bonds and insurance certificates (if applicable).
 - 3. Distribution of Contract Documents (if applicable).
 - 4. Submission of complete **[list of Subcontractors,]** list of Products, schedule of values, and progress schedule.
 - 5. Designation of personnel representing the parties in Contract, **[_____,]** and the Architect/Engineer.

Section 01039

COORDINATION AND MEETINGS

6. Procedures and processing of field decisions, submittals, **[substitutions]**, applications for payments, proposal request, Change Orders, and Contract closeout procedures.
7. Scheduling.
8. Scheduling activities of a(n) **[Geotechnical Engineer,] [Special Inspector] [_____].**
9. Site Mobilization
 - a. Use of premises by Owner and Contractor.
 - b. Owner's requirements **[and [partial] occupancy].**
 - c. Construction facilities and controls provided by Owner.
 - d. Temporary utilities.
 - e. Survey and layout.
 - f. Security and housekeeping procedures.
10. **[Owner] [Architect] [Construction Manager]** will record minutes and distribute copies.

1.8 PROGRESS MEETINGS

- A. **[Architect] [Construction Manager]** will schedule and administer meetings throughout progress of the Work at weekly intervals.
- B. **[Architect/Engineer,] [Construction Manager]** will make arrangements for meetings, prepare agenda with copies for participants, preside at meetings.
- C. Attendance Required: Job superintendent, major Subcontractors and suppliers, Owner, **[Architect/Engineer,] [Construction Manager,]** as appropriate to agenda topics for each meeting.
- D. Agenda:
 1. Progress noted.
 2. Schedule Status/Look Ahead.
 3. Contractual and Administrative Items.
 4. Job Safety/Cleanliness.

Section 01039

COORDINATION AND MEETINGS

- 5. Old Business.
 - 6. New Business.
 - 7. Clarifications.
 - E. **[Architect/Engineer] [Construction Manager]** will record minutes and distribute copies of meeting minutes.
- 1.9 PREINSTALLATION MEETINGS
- A. When required in individual specification sections, convene a preinstallation meeting at **[the site] [_____]** prior to commencing work of the section.
 - B. Require attendance of parties directly affecting, or affected by, work of the specific section.
 - C. Notify Architect/Engineer, Owner, **[Construction Manager] [one week] [_____]** days in advance of meeting date.
 - D. Prepare agenda and preside at meeting:
 - 1. Review conditions of installation, preparation and installation procedures.
 - 2. Review coordination with related work.
 - E. **[Architect/Engineer] [Construction Manager]** will record minutes and distribute copies of minutes.
- 2 PART 2 PRODUCTS
- Not Used
- 3 PART 3 EXECUTION
- 4 Not Used

END OF SECTION

Section 01043

PARTNERING

1 PART 1 GENERAL

1.0 RELATED DOCUMENTS

- A. Drawings and general provisions of Contract, including General and Supplementary Conditions and other Division 1 Specifications Sections, apply to this section.

1.1 SUMMARY

- A. Section includes:

- 1. Owner's intention for partnering.
- 2. Goals and concepts of partnering.
- 3. Team building workshop.

1.2 INTENTION

- A. The Owner expects a cohesive team-orientated relationship between the successful contractor, its suppliers and subcontractors, the Architect/Engineer, **Construction Manager** and the Owner to accomplish the Work under this Contract.
- B. This relationship will be structured to draw on the strengths of each organization to identify and achieve such mutual beneficial goals as a quality project done right the first time, within the contract prices at all levels and on schedule.
- C. The terms of Partnering arrangement will be negotiated and agreed upon by all concerned.

1.3 GOALS AND CONCEPTS

- A. Other supplemental information is outlined below to assist the contractor in understanding the intended goals and concepts.
- B. The concept of Partnering involves developing a cooperative management team consisting of the key players from the organizations involved in the construction project. The team focuses on common goals and benefits to be achieved during project execution and develops processes to keep the team working toward those goals. The idea is best summarized as an environment that nurtures team building cooperation. Successful Partnering depends upon both commitment and communication. All team members need to participate in the identification of goals and objectives for the project, and also in the decisions as to how these goals and objectives can best be achieved.
- C. The Partnering relationship will be multilateral. To implement this partnering initiative, it is anticipated that, within 30 calendar days of a Notice to Proceed, the project managers and key management representatives of all the team members will

Section 01043

PARTNERING

attend an initial partnering (team-building) workshop. Follow-up workshops will be held periodically throughout the duration of the Contract as agreed to by the team members.

- D. An integral aspect of partnering is the resolution of problems or disputes in a timely, professional and non-adversarial manner. A project dispute resolution process will be developed to assist in promoting and maintaining an amicable working relationship. This process is intended to be a non-binding procedure available for use by the parties to this Contract to resolve any dispute that may arise during performance of the Work.
- E. Good working relationships need to be developed between team members. These relationships form a basis for trust and understanding between team members and thus foster more open communications between them.

1.4 TEAM BUILDING WORKSHOP

- A. Certain topics and agenda items for a typical team building workshop include, but are not limited to, those listed below:
 - 1. The Work.
 - 2. The Challenge.
 - 3. The Players—the Champions.
 - 4. Team Goals (derived by team members: Contractor, Owner, Architect/Engineer, **Construction Manager,** Subcontractor/Supplier)
 - 5. Action Plans for:
 - a. Accident prevention.
 - b. Achieving the desired quality product.
 - c. Continuing the partnering commitment.
 - d. Project dispute resolutions (informal procedures)

2 PART 2 PRODUCTS

Not Used.

3 PART 3 EXECUTION

Not Used.

DIVISION 1

UA No.

Section 01043

PARTNERING

END OF SECTION

Section 01045

CUTTING AND PATCHING

1 PART 1 GENERAL

1.1 SECTION INCLUDES

A. Requirements and limitations for cutting and patching of Work.

1.2 RELATED SECTIONS

A. Section 01010 – Summary of Work for Work by Owner or by separate contractors.

B. Section 01300 – Submittals.

C. Section 01500 – Construction Facilities and Temporary Controls for cleaning requirements.

D. Section 01600 – Material and Equipment.

E. Section [] – Selective Demolition for demolition of selected portions of the building for alterations.

F. Section [] – Firestopping.

G. Individual Product Specification Sections.

1. Cutting and patching incidental to work of the section.

2. Coordination of required openings.

3. Limitations on cutting structural members.

4. Division 15 and 16 Sections for other requirements and limitations applicable to cutting and patching mechanical and electrical installations.

1.3 SUBMITTALS

A. Submit written request in advance of cutting or alteration which affect:

1. Structural integrity of any element of Project, including its load-carrying capacity or load/deflection ratio.

2. Integrity of weather exposed or moisture resistant element.

3. Efficiency, maintenance, or safety of any operational element.

4. Visual qualities of sight exposed elements.

5. Work of Owner or separate contractor.

B. Include in request:

Section 01045**CUTTING AND PATCHING**

1. Identification of Project.
2. Location and description of affected Work.
3. Necessity for cutting or alteration.
4. Description of proposed Work and Products to be used.
5. Firms or entities that will perform work.
6. Alternatives to cutting and patching.
7. Effect on work of Owner or separate contractor.
8. Written permission of affected separate contractor.
9. Date and time the Work will be executed.
10. Utilities that will be disturbed or affected. List utilities that will be relocated and those that will be temporarily out of service. Indicate how long service will be disrupted.
11. Details and engineering calculations for any required structural reinforcement and how reinforcement is integrated with the original structure.

1.4 QUALITY ASSURANCE

- A. Do not cut and patch structural elements in a manner that would change their load-carrying capacity or load-deflection ratio.
 1. Obtain approval of the cutting and patching proposal before cutting and patching the following structural elements:
 - a. Structural Concrete.
 - b. Structural Steel.
 - c. Structural Decking.
 - d. Stair Systems.
 - e. Miscellaneous structural metals.
 - f. Equipment supports.
 - g. Piping, ductwork, vessels, and equipment.
- B. Operational Limitations: Do not cut and patch operating elements or related components in a manner that would result in reducing their capacity to perform as intended. Do not cut and patch operating elements or related components in a manner that would result in increased maintenance or decreased operational life or safety.

Section 01045

CUTTING AND PATCHING

1. Obtain approval of the cutting and patching proposal before cutting and patching the following operating elements or safety related systems:
 - a. Primary operational systems and equipment.
 - b. Air or smoke barriers.
 - c. Water, moisture, or vapor barriers.
 - d. Membranes and flashings.
 - e. Fire protection systems.
 - f. Noise and vibration control elements and systems.
 - g. Control systems.
 - h. Communication systems.
 - i. Electrical wiring systems.

C. Visual Requirements: Do not cut and patch construction exposed on the exterior or in occupied spaces in a manner that would, in the Architect's opinion, reduce the building's aesthetic qualities. Do not cut and patch construction in a manner that would result in visual evidence of cutting and patching. Remove and replace construction cut and patched in a visually satisfactory manner.

D. Warranty:

1. Existing Warranties: Replace, patch, and repair material and surfaces cut or damaged by methods and with materials in such a manner as not to void any warranties required or existing.

2 PART 2 PRODUCTS

2.1 MATERIALS

A. Primary Products: Use materials identical to existing materials. For exposed surfaces, use materials that visually match existing adjacent surfaces to the fullest extent possible if identical materials are not available or cannot be used. Use materials whose installed performance will equal or surpass that of existing materials.

3 PART 3 EXECUTION

3.1 EXAMINATION

- A. Examine existing conditions prior to commencing Work, including elements subject to damage or movement during cutting and patching.
- B. Meet at the project site with parties involved in cutting and patching, including mechanical and electrical trades. Review areas of potential interference and conflict. Coordinate procedures and resolve conflicts before proceeding.
- C. After uncovering existing Work, assess conditions affecting performance of work.

Section 01045

CUTTING AND PATCHING

- D. Beginning of cutting or patching means acceptance of existing conditions.

3.2 PREPARATION

- A. Coordinate work of alterations and renovations to expedite completion and to accommodate Owner occupancy.
- B. Provide temporary supports to ensure structural integrity of the Work. Provide devices and methods to protect other portions of Project from damage.
- C. Provide protection from elements for areas, which may be exposed by uncovering work.
- D. Maintain excavations free of water.
- E. Avoid interference with use of adjoining areas or interruption of free passage to adjoining areas.
- F. Avoid cutting existing pipe, conduit, or ductwork serving the building but scheduled to be removed or relocated until provisions have been made to by pass them.

3.3 INSTALLATION

- A. Remove, cut, and patch Work in a manner to minimize damage and to provide a means of restoring products and finishes to **[original] [specified]** conditions.
- B. In addition to specified replacement of **[equipment] [and] [fixtures]** restore existing **[plumbing,] [heating,] [ventilation,] [air conditioning,] [electrical,] [and] [_____]** systems to full operational condition.
- C. Re-cover and refinish Work that exposes mechanical and electrical work exposed accidentally during the work.

3.4 CUTTING

- A. Execute cutting and fitting to complete the Work.
- B. Remove and replace defective or non-conforming work.
- C. Remove samples of installed work for testing when requested.
- D. Provide openings in the Work for penetration of mechanical and electrical work.
- E. Employ skilled and experienced installer to perform cutting for weather exposed and moisture resistant elements, and sight exposed surfaces.
- F. Cut rigid materials using masonry saw or core drill. Pneumatic tools not allowed without prior approval.

Section 01045

CUTTING AND PATCHING

3.5 PATCHING

- A. Execute patching to complement adjacent Work.
- B. Fit products together to integrate with other Work.
- C. Execute work by methods to avoid damage to other Work, and which will provide appropriate surfaces to receive patching and finishing.
- D. Employ approved installer to perform patching for weather exposed and moisture resistant elements, and sight-exposed surfaces.
- E. Restore work with new products in accordance with requirements of Contract Documents.
- F. Fit work to pipes, sleeves, ducts, conduit, and other penetrations through surfaces.
- G. At penetrations of fire rated walls, partitions, ceiling, or floor construction, completely seal voids with **[fire rated] [fire resistant] [_____]** material **[in accordance with Section 07270] [_____]**, to full thickness of the penetrated element.
- H. Patch or replace portions of existing surfaces, which are damaged, lifted, discolored, or showing other imperfections.
- I. Repair substrate prior to patching finish.
- J. Refinish surfaces to match adjacent finish. For continuous surfaces, refinish to nearest intersection or natural break. For an assembly, refinish entire unit.
 - 1. Where Work abuts or aligns with existing, perform a smooth and even transition. Patch Work to match existing adjacent Work in texture and appearance.
 - 2. When finished surfaces are cut so that a smooth transition with new Work is not possible, terminate existing surface along a straight line at a natural line of division and make recommendation to Architect/Engineer.
 - 3. Where removal of partitions or walls result in adjacent spaces becoming one, rework floors, walls, and ceilings to a smooth plane without breaks, steps, or bulkheads.
 - 4. Where a change of plane of **[1/4] [_____] inch [[6] [_____]mm]** or more occurs, request instructions from **[Architect/Engineer] [Construction Manager] [Owner]**.
 - 5. Trim existing doors as necessary to clear new floor finish. Refinish trim as required.

DIVISION 1

UA No.

Section 01045

CUTTING AND PATCHING

END OF SECTION

Section 01050

FIELD ENGINEERING

- 1 PART 1 GENERAL
- 1.1 SECTION INCLUDES
 - A. Quality assurance.
 - B. Submittals for review.
 - C. Project Record Documents.
 - D. Examination.
 - E. Survey reference points.
 - F. Survey requirements.
- 1.2 RELATED SECTIONS
 - A. Document 00200 – Information Available to **[Bidders.] [CM@Risk.]**
 - B. Document **[00700 – General Conditions]. [00700CM – General Conditions (CM Edition)].**
 - C. Section 01700 – Contract Closeout.
- 1.3 QUALITY ASSURANCE
 - A. Employ an individual acceptable to Architect/Engineer to perform survey work of this section.
 - B. Submit evidence of satisfactory completion of a number of similar projects within last 5 years.
 - C. Employ a Professional Engineer of the discipline required for specific service on Project, licensed in the State of Arizona.
- 1.4 SUBMITTALS FOR REVIEW
 - A. Submit name, address, and telephone number of proposed individual before starting survey work.
 - B. On request, submit documentation verifying accuracy of survey work.
 - C. Submit a copy of site drawing signed by the responsible individual, certifying that the elevations and locations of the Work are in conformance with Contract Documents.

Section 01050

FIELD ENGINEERING

1.5 PROJECT RECORD DOCUMENTS

- A. Maintain a complete and accurate log of control and survey work as it progresses.
- B. On completion of foundation walls, major site improvements, and underground utilities, prepare and submit a survey showing as-built locations.
- C. Maintain and submit Record Documents under provisions of Section 01700.

1.6 EXAMINATION

- A. Verify locations of survey control points prior to starting work.
- B. Prior to commencing work, carefully check existing conditions and compare all drawings that in any way affect the location or elevation of the Work, and immediately report any discrepancy to Architect for verification and adjustments. Any duplication of work made necessary by failure or neglect to comply with this requirement shall be done at Contractor's sole expense.
- C. Promptly notify **[Architect/Engineer]** **[Construction Manager]** of any discrepancies discovered.

1.7 SURVEY REFERENCE POINTS

- A. Contractor confirm and protect survey control and reference points.
- B. Protect survey control points prior to starting site work; preserve permanent reference points during construction.
- C. Promptly report to **[Architect/Engineer]** **[Construction Manager]** **[Owner]** the loss or destruction of any reference point or relocation required because of changes in grades or other reasons.
- D. Replace dislocated survey control points based on original survey control. Make no changes without prior written notice to **[Architect/Engineer]** **[Construction Manager]** **[Owner]**.

1.8 SURVEY REQUIREMENTS

- A. Provide field engineering services. Utilize recognized engineering survey practices. Working from existing or Owner established reference points, establish and maintain bench marks and other dependable markers, and set lines and levels for the work at each story of construction and elsewhere on site as needed to properly locate each element of entire project. Calculate and measure required dimensions as shown within recognized tolerances. Do not scale drawings to determine dimensions. Advise tradesmen performing the work of the marked lines and levels provided for their use in layout of work.

Section 01050

FIELD ENGINEERING

- B. Establish a minimum of two permanent bench marks on site, referenced to established control points. Record locations, with horizontal and vertical data, on project record documents.
- C. Establish elevations, lines and levels. Locate and lay out by instrumentation and similar appropriate means:
 - 1. Site improvements including pavements; stakes for grading, fill and topsoil placement; utility locations, slopes, and invert elevations; **[and]** [_____].
 - 2. Grid or axis for structures.
 - 3. Building foundation, column locations, ground floor elevations, **[and]** [_____].
- D. Periodically verify layouts by same means.

2 PART 2 PRODUCTS

Not Used.

3 PART 3 EXECUTION

Not Used.

END OF SECTION

Section 01090

REFERENCE STANDARDS

1 PART 1 GENERAL

- A. Conform to reference standard by date of issue on date of Contract Documents except where a specific date is established by code or in individual specification section.
- B. Obtain copies of standards where required by product specification sections.
- C. Neither the contractual relationships, duties, or responsibilities of the parties in Contract nor those of the Architect/Engineer shall be altered from the Contract Documents by mention or inference otherwise in any reference document.

1.1 SECTIONS INCLUDES

- A. Quality assurance.
- B. Applicable Standards.

1.2 RELATED SECTIONS

1.3 QUALITY ASSURANCE

- A. Throughout the Contract Documents, reference is made to Codes and Standards which establish qualities and types of workmanship and materials and which establish methods for testing and reporting on the pertinent characteristics.
- B. Work Included: Where materials or workmanship are required by these Contract Documents to meet or exceed the specifically named Code or Standard, it is the Contractor's responsibility to provide materials and workmanship which meet or exceed the specifically named Code or Standard.
- C. Related Work: Specific naming of the Codes or Standards occurs on the Drawings and in other Sections of these Specifications.
- D. Quality Control: It is the Contractor's responsibility to verify the requirements of the specifically named Codes and Standards to verify that the items produced for this work meet or exceed the specified requirements.
- E. The Architect/Engineer reserves the right to reject items incorporated in the work which fail to meet the specified minimum requirements or accept non-complying items subject to an adjustment in the Contract amount approved by the Architect and the Owner.

1.4 APPLICABLE STANDARDS:

- A. Applicable standards listed in these Specifications may include, but are not limited to:

Section 01090

REFERENCE STANDARDS

AAMA	Architectural Aluminum Manufacturing Association 35 East Wacker Drive Chicago, IL 60601
ACI	American Concrete Institute Box 10150, Redford Station Detroit, MI 48219
ADA	Americans with Disabilities Act, Public Law 101-336 Office of the Americans with Disabilities Act Civil Rights Division U.S. Department of Justice Washington, D.C. 20530
AISC	American Institute of Steel Construction Inc. 122 Avenue of the Americas New York, NY 10020
AMCA	Air Movement and Control Association 30 West University Drive Arlington Heights, IL 60004
ANSI	American National Standards Institute (successor to USASI & ASA) 1430 Broadway New York, NY 10018
A.P.A.	American Plywood Association P.O. Box 11700 Tacoma, WA 98411
ASTM	American Society for Testing and Materials 1916 Race Street Philadelphia, PA 19103
A.W.I.	Architectural Woodwork Institute 2310 South Walter Reed Drive Arlington, VA 22206
AWS	American Welding Society, Inc. 2501 N.W. 7th Street Miami, FL 33125
AWWA	American Water Works Association, Inc. 6666 West Quincy Avenue Denver, CO 80235
CRSI	Concrete Reinforcing Steel Institute

DIVISION 1**UA No.****Section 01090****REFERENCE STANDARDS**

	228 North LaSalle Street Chicago, IL 60610
CS	Commercial Standard of NBS U.S. Department of Commerce Government Printing Office Washington, D.C. 20402
FGMA	Flat Glass Marketing Association 3310 Harrison Topeka, KS 66611
NAAMM	The National Association of Architectural Metal Manufacturers 1033 South Boulevard Oak Park, IL 60302
NEC	National Electrical Code (See NFPA)
NEMA	National Electrical Manufacturer's Association 155 East 44 Street New York, NY 10017
NFPA	National Fire Protection Association 470 Atlantic Avenue Boston, MA 02210
NRCA	National Roofing Contractors Association 8600 Bryn Mawr Avenue Chicago, IL 60631-3502
OSHA	Occupational Safety Health Administration Government Printing Office Washington, D.C. 20402
SAMA	Scientific Apparatus Makers Association 1101 16th Street Washington, D.C. 20036
S.D.I.	Steel Door Institute 712 Lakewood Center N. Cleveland, OH 44107
SDI	Steel Deck Institute 135 Addison Avenue Elmhurst, IL 60125
SSPC	Steel Structures Painting Council 4400 5th Avenue Pittsburg, PA 15213

Issued October 2007

Section 01090

REFERENCE STANDARDS

SMACNA	Sheet Metal & Air Conditioning Contractors National Association 8224 Old Courthouse Road Vienna, VA 22180
TCA	Tile Council of America, Inc. P.O. Box 326 Princeton, NJ 08540
IBC	International Building Code International Building Code Council Los Angeles District Office 5360 South Workman Mill Road Whittier, CA 90601
UL	Underwriter's Laboratories, Inc. 207 East Ohio Street Chicago, IL 60611
IMC	International Mechanical Code International Mechanical/Plumbing Code Council Los Angeles District Office 5360 South Workman Mill Road Whittier, CA 90601
IPC	International Plumbing Code International Mechanical/Plumbing Code Council Los Angeles District Office 5360 South Workman Mill Road Whittier, CA 90601

FED SPEC & FED STANDARDS

Specifications Sales (3FRI) Bldg. 197
Washington Navy Yard
General Services Administration
Washington, D.C. 20407

- B. Governing authorities have been contacted where necessary to obtain information needed for the preparation of Contract Documents. It is the Intention of the Contract Document to comply with all applicable laws, statues, building codes, and regulations.
- C. Codes and Guidelines referred to in the preparation of these Contract Documents include, but are not necessarily limited to, the latest edition and/or most recent revision of the following:
 - 1. Arizona State Fire Code.

DIVISION 1

UA No.

Section 01090

REFERENCE STANDARDS

2. International Building Code (2003).
3. International Plumbing Code (2003).
4. International Mechanical Code (2003).
5. National Electrical Code (2003).
6. National Fire Protection Association Codes (in total).
7. Life Safety Code (NFPA 101).
8. Occupational Safety and Health Administration Regulations.
29 CFR 1910 and 1926.
9. ANSI A. 117.1 (handicapped accessibility).
10. Arizona Revised Statutes, including:
 - 41-1492 et seq (handicapped accessibility)
 - 34-451 (energy conservation standards)
 - 34-452 (solar design standards and energy life cycle costing)
11. The Americans with Disabilities Act Accessibility Guidelines (ADAAG)
12. IAQ Guidelines for Occupied Buildings Under Construction.

2 PART 2 PRODUCTS

Not Used

3 EXECUTION

Not Used

END OF SECTION

Issued October 2007

Section 01120

ALTERATION PROJECT PROCEDURES

- 1 PART 1 GENERAL
 - 1.1 SECTION INCLUDES
 - A. Products and installation for patching and extending work.
 - B. Transition and adjustments.
 - C. Repair of damaged surfaces, finishes, and cleaning.
 - 1.2 RELATED SECTIONS
 - A. Section 01039 – Coordination and Meetings: **[Work sequence,] [Owner occupancy,] [maintenance of utility services,] [and] [_____].**
 - B. Section **[01039 – Coordination and Meetings:] [01045 – Cutting and Patching:] [Cutting and patching.] [_____].**
 - C. Section **[_____ - _____]:** Special procedures for historic restorations.
 - D. Section 01500 – Construction Facilities and Temporary Controls: **[Temporary enclosures,] [protection of installed work,] [and] [cleaning during construction].**
- 2 PART 2 PRODUCTS
 - 2.1 PRODUCTS FOR PATCHING AND EXTENDING WORK
 - A. New Materials: As specified in product sections; match existing Products and work for patching and extending work.
 - B. Type and Quality of Existing Products: Determine by inspecting and testing Products where necessary, referring to existing Work as a standard.
- 3 PART 3 EXECUTION
 - 3.1 EXAMINATION
 - A. Verify that demolition is complete and areas are ready for installation of new Work.
 - B. Beginning of restoration Work means acceptance of existing conditions.
 - C. The Installer or Subcontractor of each element of work must examine the conditions of the substrate to receive the work, dimensions and spaces adjacent, tolerances, interfacing with other elements and services, and the conditions under which the work will be performed, and must notify the Contractor in writing of conditions detrimental to the proper or timely completion of the work. If work proceeds the substrate will be deemed accepted by Installer or Subcontractor. Do not proceed

Section 01120

ALTERATION PROJECT PROCEDURES

with the work until unsatisfactory conditions have been corrected in a manner acceptable to the Installer.

3.2 PREPARATION

- A. Cut, move, or remove items as necessary for access to alterations and renovation Work. Replace and restore at completion.
- B. Remove unsuitable material not marked for salvage, such as rotted wood, corroded metals, and deteriorated masonry and concrete. Replace materials as specified for finished Work.
- C. Remove debris and abandoned items from area and from concealed spaces.
- D. Prepare surface and remove surface finishes to provide for proper installation of new work and finishes.
- E. Close openings in exterior surfaces to protect existing work **[and salvage items]** from weather and extremes of temperature and humidity. Insulate duct work and piping to prevent condensation in exposed areas.

3.3 INSTALLATION

- A. Coordinate work of alterations and renovations to expedite completion **[sequentially] [and] [to accommodate Owner occupancy]**.
- B. Remove, cut, and patch Work in a manner to minimize damage and to provide a means of restoring Products and finishes to **[original] [specified]** condition **[in accordance with Section [01039] [01045]]**.
- C. Refinish visible existing surfaces to remain in renovated rooms and spaces, to specified condition for each material, with a neat transition to adjacent finishes **[in accordance with Section [01039] [01045]]**.
- D. **[Project,] [Designated areas,] [Rooms and spaces,] [and] [Finishes]:** Complete **[including operational mechanical and electrical work] [and] [_____]**.
- E. In addition to specified replacement of **[equipment] [and] [fixtures]** restore existing **[plumbing,] [heating,] [ventilation,] [air conditioning,] [electrical,] [and] [_____]** systems to full operational condition.
- F. Re-cover and refinish Work that exposes mechanical and electrical work exposed accidentally during the work.
- G. Install Products as specified in individual sections.

3.4 TRANSITIONS

Section 01120

ALTERATION PROJECT PROCEDURES

- A. Where new Work abuts or aligns with existing, perform a smooth and even transition. Patch Work to match existing adjacent Work in texture and appearance.
- B. When finished surfaces are cut so that a smooth transition with new Work is not possible, terminate existing surface along with straight line at a natural line of division and make recommendation to Architect/Engineer.

3.5 ADJUSTMENTS

- A. Where removal of partitions or walls results in adjacent spaces becoming one, rework floors, walls, and ceilings to a smooth plane without breaks, steps, or bulkheads.
- B. Where a change of plane of 1/4 [_____] inch (6 [_____] mm) or more occurs, **submit recommendation for providing a smooth transition for Architect/Engineer [Construction Manager] [Owner] review. [request instructions from Architect/Engineer.] [Construction Manager] [Owner] [_____].**
- C. Trim existing doors as necessary to clear new floor finish. Refinish trim as required.
- D. Work at penetrations of surfaces as specified in Section **01045.** [_____].

3.6 REPAIR OF DAMAGED SURFACES

- A. Patch or replace portions of existing surfaces which are damaged, lifted, discolored, or showing other imperfections.
- B. Repair substrate prior to patching finish.

3.7 FINISHES

- A. Finish surfaces as specified in individual Product sections.
- B. Finish patches to produce uniform finish and texture over entire area. When finish cannot be matched, refinish entire surface to nearest intersections.

3.8 CLEANING

- A. In addition to cleaning specified in Section **01500** [_____], clean Owner occupied areas of work.

END OF SECTION

1 PART 1 GENERAL

1.1 SECTION INCLUDES

- A. Submittal Procedures.
- B. Submittal Log.
- C. Construction Progress Schedules.
- D. Proposed Products List.
- E. Product Data.
- F. Shop Drawings.
- G. Samples.
- H. Design Data.
- I. Electronic Files.
- J. Test reports.
- K. Certificates.
- L. Manufacturer's Instructions.
- M. Manufacturer's Field Reports.
- N. Erection Drawings.
- O. Construction Photographs.

1.2 RELATED SECTIONS

- A. Section 01027 – Applications for Payment.
- B. Section 01400 – Quality Control.
- C. Section 01700 – Contract Closeout.

1.3 REFERENCES

- A. AGC (Associated General Contractors of America) publication "Construction Planning and Scheduling", June 1997.

Section 01300

SUBMITTALS

1.4 SUBMITTAL PROCEDURES

- A. Transmit each submittal with **[Architect/Engineer]** **[Construction Manager]** **[Owner]** accepted form.
- B. Sequentially number submittals in the following format:

Section number. submittal number. submission number.
Example: 15300.1.1 First shop drawing submittal. First submission.
15300.2.1 Second shop drawing submittal. First submission
- C. Identify Project, Contractor, Subcontractor or supplier; pertinent drawing and detail number, and specification section number, as appropriate.
- D. Apply Contractor's stamp, signed or initialed certifying that review, approval, verification of Products required, field dimensions, adjacent construction Work, and coordination of information is in accordance with the requirements of the Work and Contract Documents.
- E. Schedule submittals to expedite the Project, and deliver to **[Architect/Engineer]** **[Construction Manager]** **[Owner]** [] at **[location]** Coordinate submission of related items.
- F. For each submittal for review, allow **[20]** [] days excluding delivery time to and from the Contractor.
- G. Identify variations from Contract Documents and Product or system limitations which may be detrimental to successful performance of the completed Work.
- H. Provide space for Contractor **[Construction Manager]** and Architect/Engineer review stamps.
- I. When revised for resubmission, identify all changes made since previous submission.
- J. Distribute copies of reviewed submittals as appropriate. Instruct parties to promptly report any inability to comply with requirements.
- K. Submittals not requested will not be recognized or processed.

1.5 SUBMITTAL LOG

- A. Submittal Log: Within 14 days of Notice to Proceed the Contractor shall submit a Submittal log and Submittal schedule for review and approval by the Architect. The log shall include a list of all Shop Drawings, Materials List and Literature and Samples specified to be submitted and organized by specification section.

1.6 CONSTRUCTION PROGRESS SCHEDULES

Section 01300

SUBMITTALS

- A. Submit initial schedule in duplicate within **[10] [20] [_____]** days after date **[of Owner-Contractor Agreement.] [established in Notice to Proceed.]** No payment requests from Contractor will be paid after **[10] [20] [_____]** calendar days after Notice to Proceed unless the initial project schedule has been submitted and agreed to in principle.
- B. Revise and resubmit as required.
- C. Submit revised schedules with **[each] [_____]** Application for Payment, identifying changes since previous version.
- D. Submit a computer generated **[or hand-drawn]** comprehensive horizontal bar chart with separate line for each major portion of Work or operation to be performed at the Project Site, identifying first work day of each week and showing completion of the Work by the date established for Substantial Completion.

***** **[OR]** *****

- D. Submit computer generated network analysis diagram using the critical **path** method, as outlined in AGC – “Construction Planning and Scheduling”, June 1997, showing completion of the Work by the date established for Substantial Completion.
- E. The schedule shall incorporate all schedule constraints (phasing or sequence of construction, delivery windows for Owner furnished items, interim milestone dates, etc.) specified in the Contract Documents.
- F. The schedule shall show separate procurement activities for all specially fabricated or custom produced items of material or equipment including order, design, submittals, fabrication and delivery.
- G. The schedule shall include separate activities for both submittal and review of all required submittals. The minimum time allocated for review and return of submittals and all resubmittals shall be **[__ days]** as stated in Subsection 1.4 above for each submittal or resubmittal. Indicate submittal dates required for shop drawings, product data, samples, and product delivery dates, including those furnished by Owner and required by Allowances.
- H. Secure critical time commitments for performing major elements of the Work by meeting with subcontractors and material suppliers to ascertain crew size, anticipated production, and lead times for materials and equipment to be incorporated into the Work. The schedule shall demonstrate fulfillment of all Contract requirements so that it can be utilized for scheduling, coordinating, and monitoring work under this Contract.
- I. Submit schedule for initial approval and then update and resubmit monthly or more often as required in order to demonstrate contract compliance and facilitate evaluation of monthly payment requests and requests for time extension. All monthly updates shall show schedule revisions and actual progress **[by use of additional parallel time bars for each activity, while retaining the original approved schedule time bars.]**

- J. At the preconstruction conference, Contractor shall submit a preliminary **[major milestone type]** project schedule **[and a 90-day “look ahead” schedule for the work to be done during the first 90 days of the Contract Time.]** No onsite construction work will be permitted and no progress payments will be made by Owner until the **[preliminary 90-day] [preliminary] [project]** schedule has been submitted **[and approved.]**
- K. Show the sequence and interdependence of activities required for complete performance of all items of work under this Contract or portion thereof. Show complete and proper sequence of construction by activity, identifying Work of separate stages and other logically grouped activities. **[Indicate the early and late start, early and late finish, float dates, and duration.]** Preparing the schedule:
1. Exercise sufficient care to produce a clear, legible, and accurate schedule. Activities related to specific physical areas of the project shall be grouped on the schedule for ease of understanding and simplification.
 2. In addition to the performance of work in place, show special activities such as:
 - a. Interruption of utilities, delivery of Owner furnishings and equipment, special inspections, or other project phasing requirements.
 - b. Testing and balancing of mechanical equipment, special testing, equipment start-up, Owner training, etc.
 - c. Final cleaning, punch list inspections, final inspection, demobilization.
 3. Break up the Work into activities of a duration no longer than 20 work days each, except as to non-construction activities (such as procurement of materials, delivery of equipment and concrete curing) and any other activities for which the Owner may approve the showing of longer duration.
 4. Show time periods for the start-up and shakedown operation of the following systems:
 - a. HVAC
 - b. Life Safety Systems
 - c. Elevators
 - d. **(Other special systems as applicable)**
- L. Submit the following supporting data with the schedule:
- a. The proposed number of working days per week.
 - b. The holidays to be observed during the life of the Contract (by day, month, and year).
 - c. The planned number of shifts per day.
- M. Unless otherwise agreed upon, the schedule format shall be 11” x 17” minimum.

Section 01300

SUBMITTALS

- N. All changes to the Work resulting in a time change shall be reflected in the schedule. Minor changes may be omitted from the schedule provided that there is no change in time and that the Owner is in agreement with the procedure.
- O. Following initial submittal and response by Owner, print and distribute Construction schedule to Owner (____ copies), Architect (____ copies), [**Construction Manager (____ copies)**] subcontractors, suppliers, fabricators, and other with schedule-compliance requirements. Post copies in Project meeting rooms and field office. When revisions are made, distribute updated issues to same entities. Those who are no longer involved in performance of scheduled work may be deleted from distribution list.
- P. The submittal of monthly schedule updates by the Contractor shall be a condition precedent to the making of monthly progress payments by the Owner.
- Q. Owner may request expediting of material and equipment deliveries without assuming the responsibility for said deliveries. Upon request, furnish to the Owner copies of equipment and material purchase orders complete with scheduled shipping and receiving dates.
- R. When the monthly update of the schedule indicates that any critical activity directly affecting completion of the Project will not be completed as scheduled, Contractor shall take some or all of the following actions at no additional cost to the Owner unless the late completion of the activity is due to an excusable delay:
- a. Increase construction manpower in quantities needed to eliminate the backlog of work and put the Project back on schedule.
 - b. Increase the number of working hours per shift, shifts per working day, working days per week, or the amount of construction equipment or any combination of the foregoing which will eliminate backlog of work and put the Project back on schedule.
 - c. Reschedule activities to achieve maximum practical concurrency of accomplishment of activities and put the Project back on schedule.
- S. Ownership and Use of Float: Float is defined as the amount of time between the early and late completion dates of a scheduled activity. Float time on this Project is a project resource jointly owned by the Owner and Contractor. This resource expires as the Project progresses, and it is to be available to and consumed by the joint owners on a first-come first-served basis. If Contractor's schedule indicates a completion date for the project prior to the contractual completion date, then the time period between the two dates shall be considered as project float and shall be owned and used in accordance with this paragraph.

1.7 PROPOSED PRODUCTS LIST

- A. Within **[15]** [____] days after date of Notice to Proceed, submit list of major products proposed for use, with name of manufacturer, trade name, and model number of each product.

Section 01300

SUBMITTALS

- B. For products specified only by reference standards, give manufacturer, trade name, model or catalog designation, and reference standards.
- C. Overstock Materials Log: Within 15 days of Notice to Proceed, the Contractor will submit a list of all materials and quantities specified as extra stock.

1.8 PRODUCT DATA

- A. Product Data For Review:
 - 1. Submitted to Architect/Engineer, **[Construction Manager]** for review for the limited purpose of checking for conformance with information given and the design concept expressed in the contract documents.
 - 2. After review, provide copies and distribute in accordance with SUBMITTAL PROCEDURES article above and for the record documents purposes described in Section 01700 – CONTRACT CLOSEOUT.
- B. Product Data For Information:
 - 1. Submitted for the **[Architect/Engineer's] [Construction Manager's]** knowledge as contract administrator or for the Owner.
- C. Product Data For Project Close-out:
 - 1. Submitted for the Owner's benefit during and after project completion.
- D. Submit the number of copies which the Contractor requires, plus **[three]** **[_____]** copies which will be retained by the Architect/Engineer.
- E. Mark each copy to identify applicable products, models, options, and other data. Supplement manufacturers' standard data to provide information specific to this Project.
- F. Indicate Product utility and electrical characteristics, utility connection requirements, and location of utility outlets for service for functional equipment and appliances.
- G. After review, distribute in accordance with the Submittal Procedures article above and provide copies for record documents described in Section 01700 – CONTRACT CLOSEOUT.

1.9 SHOP DRAWINGS

- A. Shop Drawings For Review:
 - 1. Submitted to Architect/Engineer **[Construction Manager]** for review for the limited purpose of checking for conformance with information given and the design concept expressed in the contract documents.

Section 01300

SUBMITTALS

2. After review, produce copies and distribute in accordance with SUBMITTAL PROCEDURES article above and for record documents purposes described in Section 01700 – CONTRACT CLOSEOUT.
- B. Shop Drawings For Information:
1. Submitted for the **[Architect/Engineer's] [Construction Manager's]** knowledge as contract administrator or for the Owner.
- C. Indicate special utility and electrical characteristics, utility connection requirements, and location of utility outlets for service for functional equipment and appliances.
- D. Submit in the form of one reproducible transparency **[and] [4_____]** opaque reproductions.

1.10 SAMPLES

- A. Samples For Review:
1. Submitted to Architect/Engineer **[Construction Manager]** for review for the limited purpose of checking for conformance with information given and the design concept expressed in the contract documents.
 2. After review, produce duplicates and distribute in accordance with SUBMITTAL PROCEDURES article above and for record documents purposes described in Section 01700 – CONTRACT CLOSEOUT.
- B. Samples For Information:
1. Submitted for the **[Architect/Engineer's] [Construction Manager's]** knowledge as contract administrator for the Owner.
- C. Samples For Selection:
1. Submitted to Architect/Engineer for aesthetic, color, or finish selection.
 2. Submit samples of finishes, textures, and patterns for Architect/Engineer selection, as specified in individual specification sections.
 3. After review, produce duplicates and distribute in accordance with SUBMITTAL PROCEDURES article above and for record documents purposes described in Section 01700 – CONTRACT CLOSEOUT.
- D. Submit samples to illustrate functional and aesthetic characteristics of the Product, with integral parts and attachment devices. Coordinate sample submittals for interfacing work.
- E. Include identification on each sample, with full Project information.

Section 01300

SUBMITTALS

- F. Submit the number of samples specified in individual specification sections; **[one]** **[_____]** of which will be retained by Architect/Engineer.
- G. Reviewed samples which may be used in the Work are indicated in individual specification sections.
- H. Samples will not be used for testing purposes unless specifically stated in the specification section.

1.11 DESIGN DATA

- A. Submit for the Architect/Engineer's **[Construction Manager's]** knowledge as contract administrator or for the Owner.
- B. Submit for information for the limited purpose of assessing conformance with information given and the design concept expressed in the contract documents.

1.12 TEST REPORTS

- A. Submit for the **[Architect/Engineer's] [Construction Manager's]** knowledge as contract administrator or for the Owner.
- B. Submit test reports for information for the limited purpose of assessing conformance with information given and the design concept expressed in the contract documents.

1.13 CERTIFICATES

- A. When specified in individual specification sections, submit certification by the manufacturer, installation/application subcontractor, or the Contractor to **[Architect/Engineer] [Construction Manager]**, in quantities specified for Product Data.
- B. Indicate material or Product conforms to or exceeds specified requirements. Submit supporting reference data, affidavits, and certifications as appropriate.
- C. Certificates may be recent or previous test results on material or Product, but must be acceptable to Architect/Engineer.

1.14 MANUFACTURER'S INSTRUCTIONS

- A. When specified in individual specification sections, submit printed instructions for delivery, storage, assembly, installation, **[start-up]** adjusting, and finishing, to **[Architect/Engineer] [Construction Manager]** for delivery to Owner in quantities specified for Product Data.
- B. Indicate special procedures, perimeter conditions requiring special attention, and special environmental criteria required for application or installation.
- C. Refer to Section 01400 – Quality Control, Manufacturers' Field Service article.

Section 01300

SUBMITTALS

1.15 MANUFACTURER'S FIELD REPORT

- A. Submit reports for the Architect/Engineer's **[Construction Manger's]** benefit as contract administrator or for the Owner.
- B. Submit report **[in duplicate]** within **[30]** **[_____]** days of observation to **[Architect/Engineer]** **[Construction Manager]** for information.
- C. Submit for information for the limited purpose of assessing conformance with information given and the design concept expressed in the contract documents.

1.16 ERECTION DRAWINGS

- A. Submit drawings for the **[Architect/Engineer's]** **[Construction Manager's]** benefit as contract administrator or for the Owner.
- B. Submit for information for the limited purpose of assessing conformance with information given and the design concept expressed in the contract documents.
- C. Data indicating inappropriate or unacceptable Work may be subject to action by the **[Architect/Engineer's]** **[Construction Manager]** or Owner.

1.17 CONSTRUCTION PHOTOGRAPHS

- A. **[Twice monthly]** **[Each month]** **[On alternating months]** submit photographs **[with Application for Payment]** **[_____].**
- B. Photographs: **[One print]** **[two]** **[_____]** prints; **[color]** **[black and white]**, **[glossy]** **[matte]**; **[8 x 10]** **[_____]** inch (**[200 x 250]** **[_____]**mm) size; mounted on **[8-1/2 x 11]** **[_____]** inch (**[216 x 280]** **[_____]** mm) soft card stock, with left edge binding margin for **[three hole punch.]** **[_____].**
- C. Take **[two]** **[_____]** site photographs from differing directions and **[five]** **[_____]** interior photographs of **[_____]** indicating the relative progress of the Work, **[_____]** days maximum prior to submitting.
- D. Identify photographs with date, time, orientation, and project identification.

2 PART 2 PRODUCTS

Not Used

3 EXECUTION

Not Used.

DIVISION 1

UA No.

Section 01300

SUBMITTALS

END OF SECTION

Section 01310

CONSTRUCTION PROGRESS SCHEDULES

1 PART 1 GENERAL

1.1 SECTION INCLUDES

- A. General Requirements.
- B. Format.
- C. Content.
- D. Updating of Schedules.
- E. Revisions to Schedules.
- F. Submittals.
- G. Distribution.

1.2 RELATED SECTIONS

- A. Section **[01010 – Summary of Work:] [Work sequence.] [Owner occupancy.] [_____.]**
- B. Section 01019 – Contract Considerations.
- C. Section **[01019 – Contract Considerations] [01027 – Application for Payment.]**
- D. Section 01039 – Coordination & Meetings.
- E. Section 01300 – Submittals.

1.3 REFERENCES

- A. AGC (Associated General Contractors of America) publication “Construction Planning and Scheduling”, June 1997.

1.4 GENERAL REQUIREMENTS

- A. General: Prepare and maintain a progress schedule consisting of a computer generated network analysis system generally known as the Critical Path Method (CPM) Schedule. Proceed with the preparation immediately following first notification of Contract Award. Submit schedule and pursue the necessary steps of development and analysis as specified below. Establish regular procedures for monitoring, updating and reporting, coordinated with progress meeting dates and payment request dates.

Section 01310

CONSTRUCTION PROGRESS SCHEDULES

- The Construction Progress Schedule shall establish a baseline from which actual project progress will be measured, utilizing more than one level of schedule detail. All levels of the schedule shall roll-up into one or more summaries.
- B. The principles and definitions of the terms used herein shall be as set forth in the Associated General Contractors of America (AGC) publication, "Construction Planning and Scheduling", copyright 1997, but the provisions of this section shall govern.
- C. Program: Utilize computer hardware/software systems as approved by Owner. System shall be intended for building construction progress schedule management. The scheduling program must be capable of calculating and presenting negative float.
- D. Preliminary Schedule: At the preconstruction conference the Contractor shall submit for the Owner's review a preliminary bar chart progress schedule covering the first 30 calendar days of the Project. This schedule shall include both procurement and construction activities. The Notice to Proceed will not be issued by the Owner until this preliminary schedule has been submitted and agreed to in principle.
- E. Interim Diagram: Within 20 calendar days after issue date of Notice to Proceed, the Contractor shall submit for the Owner's review an Interim Diagram covering the first 90 calendar days of the Project in detail. The Interim Diagram shall include construction and shop drawing submission and approval activities occurring during the 90 calendar day period. Format shall be as identified in the section, except manpower shall not be required for the interim schedule. No interim progress payments will be made by Owner until the 90-day schedule has been approved.
- F. Final Network Diagram: Within **[60]** calendar days after issue date of Notice to Proceed, the Contractor shall submit for the Owner's review the complete CPM system. The submittal shall include computer-produced time-scaled network diagram(s) and tabular management reports showing the information required by this Section. The complete working diagram shall reflect the Contractor's approach to scheduling the complete project, taking into account the accuracy of the logic and the experience gained from the interim diagram. No payment requests from Contractor will be paid after **[60]** calendar days after start date contained in Notice to Proceed unless the Final CPM Diagram has been submitted and agreed to in principle.
- G. Subcontractor Participation: The Contractor shall consult with its subcontractors and suppliers relating to the preparation and updating of its construction plan and construction schedule. Subcontractors shall receive copies of those portions of the Contractor's CPM which relate to their work. They, in turn, shall supply comments on activity definitions, scope, and durations, as needed, for each activity. The Contractor shall continually advise subcontractors and suppliers of any updates or revisions to the Construction Schedule as the work progresses, and obtain their concurrence with the changes affecting their portions of the Work.
- H. The CPM schedule shall be utilized for scheduling, coordinating, and monitoring work under this Contract. The CPM Schedule shall be submitted for initial approval and then be updated and resubmitted monthly or more often as required in order to

Section 01310

CONSTRUCTION PROGRESS SCHEDULES

demonstrate contract compliance and facilitate evaluation of monthly payment requests and requests for time extension.

- I. The CPM Schedule shall consist of a time scaled Network Analysis Diagram (logic diagram), a time scaled bar chart, a cost loaded schedule (computer data printout) and any other standard tabular reports as requested by Owner, all of which shall be submitted together in triplicate.
- J. Computer-Produced Schedule: The computer produced schedule shall meet all contractual requirements, such as contract duration, phasing, and phasing restraints, and cover all procurement activities, including submittals, submittals status, fabrication and delivery times, and reflect all key long lead or critical procurement activities.
- K. Ownership and Use of Float: Float is defined as the amount of time between the early and late completion dates of a scheduled activity. Float time on this Project is a project resource jointly owned by the Owner and Contractor. This resource expires as the Project progresses, and it is to be available to and consumed by the joint owners on a first-come first-serve basis. If Contractor's schedule indicates a completion date for the project prior to the contractual completion date, then the time period between the two dates shall be considered as project float and shall be owned and used in accordance with this paragraph.

1.5 FORMAT

- A. Prepare computer generated network analysis system using the critical path method, as outlined in AGC – The Use of CPM in Construction.
- B. Network Analysis Diagram: The logic diagram shall show the sequence and interdependence of activities required for complete performance of all items of work under this Contract in the time frame allowed. The diagram shall be drafted or plotted to show a continuous flow of work, from start to finish for the entire project, reading from left to right with all activities and subnets interfaced and matchlined to allow assembly as one total project schedule.
- C. Exercise sufficient care to produce a clear, legible, and accurate diagram. Activities related to specific physical areas of the project shall be grouped on the diagram for ease of understanding and simplification. Critical path activities must be clearly identified in red. The critical path shall be plotted generally along the center of the sheet with channels with increasing floats placed towards the top or bottom.
- D. Uniquely number each activity with event numbers ranging up to 9999 only. The diagram should be generally numbered in sequence; left to right, and top to bottom. Activity number to be prefixed or suffixed with corresponding specification division. Number activities in the general progressive order that they will be completed in. Allow for inserting of additional activities should further breakdown of the work be required.

Section 01310

CONSTRUCTION PROGRESS SCHEDULES

- E. The Network Analysis Diagram must clearly show the Critical Path for the Project at all times.
- F. Sequence of Listings: [The Table of Contents of this Project Manual.] [The chronological order of the start of each item of Work.] [_____].]
- G. Scale and Spacing: To provide space for notations and revisions.
- H. Sheet Size: [_____x_____] inches.

1.6 CONTENT

- A. Activities: Before attempting to produce the CPM schedule, prepare a listing of activities involved. Include every activity having a possible bearing on the time required to complete the project. This listing of activities and levels of detail to be presented to Owner for approval.

Show the following on each work activity in alphanumeric form:

1. Work activity number (unique number identifying the work activity).
 2. Concise description of the work activity. Activity descriptions shall be unique to an activity and understandable at the working level.
 3. Duration (in work days).
 4. Total float.
 5. Early start, early finish, late start, late finish.
- B. In addition to the performance of work in place, show special activities such as:
 1. Interruption of utilities, delivery of Owner furnishings and equipment, special inspections, or other project phasing requirements.
 2. Testing and balancing of mechanical equipment, special testing, equipment start-up, Owner training, etc.
 3. Final cleaning, punch list inspections, final inspection, demobilization.
 4. Punchlist: Show two separate activities totaling a minimum of [30] work days for completion of punch list items and final cleanup.
 5. Weather Delays: Total weather delays for this project are anticipated to be [_____] work days. A [_____] work day "Planned Weather Delay" activity shall be inserted between the Contract Directed Completion Date and the Scheduled Completion Date. The planned weather delays duration will be reduced by the number of actual critical path weather delays experienced at each monthly update until the activity duration reaches 0 days. Thereafter weather delays will be an excusable delay (see General Conditions, **[Article 8]** **[Article 9]**).

Section 01310

CONSTRUCTION PROGRESS SCHEDULES

- C. Show not only the activities for actual construction work for each trade category of the project, but also include trade restrictions to indicate the movement of trades from one area, floor, etc., to another area, floor, etc., for trades who are performing major portions of the work under this contract.
- D. Break up the work into activities of a duration no longer than 20 work days each, except as to nonconstruction activities (such as procurement of materials, delivery of equipment and concrete curing) and any other activities for which the Owner may approve the showing of longer duration. The duration for Architect's approval of any required submittal, shop drawing, etc., shall be as stated in Section 01300. The construction time as determined by the Construction Progress Schedule from early start to late finish for any sub-phase, phase, or the entire project shall not exceed the Contract times indicated in Contract Documents.
- E. Describe work activities such that the work is readily identifiable for assessment of completion. Activities labeled "start", "continue", or "completion" will not be allowed. All constraints will be start finish relationships. Lead and lag time activities will be acceptable only if the description accurately identifies such a restraint and that such restraints are realistic with respect to the schedule of the project. Partial dependencies of activities will not be permitted without approval of the Owner.
- F. The schedules shall include separate activities for both submittal and review of all required submittals. The minimum time allocated for review and return of submittals and all resubmittals shall be as stated in Section 01300 for each submittal or resubmittal.
- G. The schedule shall incorporate all schedule constraints (phasing or sequence of construction, delivery windows for Owner furnished items, interim milestone dates, etc.) specified in the Contract Documents.
- H. The schedule shall show separate procurement activities for all specially fabricated or custom produced items of material or equipment including order, design, submittals, fabrication and delivery.
- I. Show complete sequence of construction by activity, with dates for beginning and completion of each element of construction.
- J. Identify work of **[separate stages]** **[separate floors]** and other logically grouped activities.
- K. Provide sub-schedules for each stage of Work identified in Section **[01010]**.
- L. Provide sub-schedules to define critical portions of the entire schedule.
- M. Include conferences and meetings in schedule.
- N. Provide separate schedule of submittal dates for shop drawings, product data, and samples, including **[Owner furnished products]** **[and]** **[Products identified under**

Section 01310

CONSTRUCTION PROGRESS SCHEDULES

Allowances], and dates reviewed submittals will be required from Architect/Engineer. Indicate decision dates for selection of finishes.

- O. Indicate delivery dates for Owner furnished products [and] Products identified under Allowances.
- P. Coordinate content with schedule of values specified in Section 01019 General Conditions CM@Risk.
- Q. The schedule shall show the following minimum time periods for the start-up and shakedown operation of the following systems:
 - 1. HVAC
 - 2. Life Safety Systems (**list**)
 - 3. Elevators
 - 4. **(Other special systems as applicable)**
[list times]

1.7 UPDATING OF SCHEDULES

- A. The CPM Schedule shall be updated monthly, or more often if required, to indicate the actual progress of the Project. Show accumulated percentage of completion of each item, and total percentage of Work completed, as of the first [] day of each month.
- B. The computer-produced report shall categorize areas of work behind schedule by use of thirty, sixty, and ninety day "look ahead" projections. Along with this data, the Contractor shall submit a narrative report as a part of this monthly review and update, in a form agreed upon by the Contractor and the Owner. The narrative report shall include the current status, a description of problem areas, current and anticipated delaying factors and their estimated impact on performance of other activities and completion dates, and an explanation of corrective action taken or proposed.
- C. The submittal of monthly schedule updates by the Contractor shall be a condition precedent to the making of monthly progress payments by the Owner.
- D. When the monthly update of the schedule shows negative float on any activity, the Contractor shall take some or all of the following actions at no additional cost to the Owner, unless the negative float is the result of an excusable delay:
 - 1. Increase construction manpower in quantities needed to eliminate the backlog of work and put the Project back on schedule.

Section 01310

CONSTRUCTION PROGRESS SCHEDULES

2. Increase the number of working hours per shift, shifts per working day, working days per week, or the amount of construction equipment or any combination of the foregoing which will eliminate backlog of work and put the Project back on schedule.
 3. Reschedule activities to achieve maximum practical concurrency of accomplishment of activities and put the Project back on schedule.
- E. If the monthly update of the schedule shows completion of the Project prior to the current contractual completion date, the time between such an early completion date and the current contractual completion date shall be identified and used as project float in accordance with Subsection 1.4.K this Section 01310.

1.8 REVISIONS TO SCHEDULES

- A. Indicate progress of each activity to date of submittal, and projected completion date of each activity.
- B. Identify activities modified since previous submittal, major changes in scope, and other identifiable changes.
- C. Provide narrative report to define problem areas, anticipated delays, and impact on Schedule. Report corrective action taken, or proposed, and its effect **[including the effect of changes on schedules of separate Contractors]**.
- D. **Changes to the Work:** With each change proposal containing a request for a time extension, Contractor shall furnish a detailed subnet and other backup information as required to support and enable ready quantitative evaluation of the request. This backup shall indicate, by event number, the activities affected, activities added, or activities deleted. The time effect shall be indicated for each activity. In the event the Contractor does not furnish the required information or an agreement cannot be reached, the Owner may direct the Contractor as to the specific logic changes and/or time adjustment which shall be entered into the schedule. All changes in the work shall be reflected in the computer produced schedule and listed in a specific fashion so as to be summarized by trade sort and incorporated into the schedule of values by change order number. Major changes shall be reflected in the Network Analysis Diagram. Minor changes may be omitted from the Network Analysis Diagram provided there is no change in time and that the Owner and Contractor are in agreement with the procedure.
 1. All changes to the Contract must be approved by the Owner prior to inclusion into the Network Analysis System. Requests for time extension as related to changes in the scope of work will be reviewed in conjunction with the revised NAS, but will not be granted or rejected on that basis alone.
 2. All costs related to the production and/or revision of the Network Analysis System including but not limited to changes in the work schedule (for whatever reason), updating requirements, reproduction, and distribution shall be borne by the Contractor. These costs shall be considered to be indirect costs only,

Section 01310

CONSTRUCTION PROGRESS SCHEDULES

recoverable as being included in the Contractor's mark-up referenced in Conditions of the Contract.

1.9 SUBMITTALS

- A. Immediately upon receipt of Notice of Intent to Award, submit a statement to the Owner **[Construction Manager]** describing Contractor's computerized scheduling capability for review and approval. This statement shall include the following as a minimum:
1. Identification, qualifications, and experience of the members of the Contractor's scheduling staff or any consultant's staff.
 2. References of not less than two previous projects on which the Contractor or Consultant has utilized computerized CPM scheduling, which were of not less than one-half of the value of the present Contract. Owner references shall be included. Actual working examples from previous projects may be requested by Owner.
 3. The name and description of the project management software and computer hardware to be utilized on this Contract.
- B. At the preconstruction conference, Contractor shall submit the preliminary schedule.
- C. Submit Interim and Final Network Diagrams in accordance with this Subsection 1.4 of this Section 01310.
- D. The Contractor shall also submit the following logic diagram supporting data:
1. The proposed number of working days per week.
 2. The holidays to be observed during the life of the Contract (by day, month, and year).
 3. The planned number of shifts per day.
 4. The number of hours per shift.
 5. The major construction equipment to be used on the site.
- E. Submit updated Progress Schedules with each Application for Payment.
- F. Submit one reproducible transparency.

1.10 DISTRIBUTION

- A. Following initial submittal and response by Owner, print and distribute Construction Schedule to Owner () copies. **[Construction Manager] () copies**, Architect () **copies**, subcontractors, suppliers, fabricators, and others with schedule-compliance

Section 01310

CONSTRUCTION PROGRESS SCHEDULES

requirements. Post copies in Project meeting rooms and field office. When revisions are made distribute updated issues to same entities. Those who are no longer involved in performance of scheduled Work may be deleted from distribution list. Revised Schedule shall be reissued with report of Progress Meeting.

- B. Instruct recipients to promptly report, in writing, problems anticipated by projections indicated in schedules.

2 PRODUCTS

Not Used.

3 EXECUTION

Not Used.

END OF SECTION

Section 01311

COST-LOADED CONSTRUCTION PROGRESS SCHEDULES

1 PART 1 GENERAL

1.1 SECTION INCLUDES

- A. General Requirements.
- B. Format.
- C. Content.
- D. Updating of Schedule.
- E. Revisions to Schedules.
- F. Submittals.
- G. Distribution.

1.2 RELATED SECTIONS

- A. Section **[01010 – Summary of Work: [Work sequence.] [Owner occupancy,] [_____.]**
- B. Section 01019 – Contract Considerations.
- C. Section **[01019 – Contract Considerations:] [01027 – Applications for Payment:]**
- D. Section **[01019 – Contract Considerations:] [01028 – Modifications Requirements:]**
- E. Section 01300 – Submittals.
- F. Section 01039 – Coordination and Meetings.

1.3 REFERENCES

- A. AGC (Associated General Contractors of America) publication "Construction Planning and Scheduling", June 1997.

1.4 GENERAL REQUIREMENTS

- A. General: Prepare and maintain a progress schedule consisting of a computer generated network analysis system generally known as the Critical Path Method (CPM) Schedule. Proceed with the preparation immediately following first notification of Contract Award. Submit schedule and pursue the necessary steps of development and analysis as specified below. Establish regular procedures for monitoring, updating and reporting, coordinated with progress meeting dates and payment request dates.

Section 01311

COST-LOADED CONSTRUCTION PROGRESS SCHEDULES

- The Construction Progress Schedule shall establish a baseline from which actual project progress will be measured, utilizing more than one level of schedule detail. All levels of the schedule shall roll-up into one or more summaries.
- B. The principles and definitions of the terms used herein shall be as set forth in the Associated General Contractors of America (AGC) publication, "Construction Planning and Scheduling", copyright 1997, but the provisions of this section shall govern.
- C. Program: Utilize Computer hardware/software systems as approved by Owner. System shall be intended for building construction progress schedule management. The scheduling program must be capable of calculating and presenting negative float.
- D. Preliminary Schedule: At the preconstruction conference the Contractor shall submit for the Owner's review a preliminary bar chart progress schedule covering the first 30 calendar days of the Project. This schedule shall include both procurement and construction activities. The Notice to Proceed will not be issued by the Owner until this preliminary schedule has been submitted and agreed to in principle.
- E. Interim Diagram: Within [] [] calendar days after receipt of Notice to Proceed, the Contractor shall submit for the Owner's review an Interim Diagram covering the first 90 calendar days of the Project in detail. The Interim Diagram shall include construction and shop drawing submission and approval activities occurring during the 90 calendar day period. Format shall be as identified in this section, except manpower shall not be required for the interim schedule. The interim schedule will be used for progress payments until final CPM system is completed.
- F. Final Network Diagram: Within **[60]** [] calendar days after receipt of Notice to Proceed, the Contractor shall submit for the Owner's review the complete CPM system. The submittal shall include computer-produced time-scaled network diagram(s) and tabular management reports showing the information required by this Section. The complete working diagram shall reflect the Contractor's approach to scheduling the complete project, taking into account the accuracy of the logic and the experience gained from the interim diagram. No payment requests from Contractor will be paid after **[60]** [] calendar days after Notice to Proceed unless the Final CPM Diagram has been submitted and agreed to in principle.
- G. Subcontractor Participation: The Contractor shall consult with its subcontractors and suppliers relating to the preparation and updating of its construction plan and construction schedule. Subcontractors shall receive copies of those portions of the Contractor's CPM which relate to their work. They, in turn, shall supply comments on activity definitions, scope, and durations, as needed, and provide the dollar value, man hours, and crew size to execute each activity. The Contractor shall continually advise subcontractors and suppliers of any updates or revisions to the Construction Schedule as the work progresses, and obtain their concurrence with the changes affecting their portions of the Work.

Section 01311

COST-LOADED CONSTRUCTION PROGRESS SCHEDULES

- H. The CPM schedule shall be utilized for scheduling, coordinating, and monitoring work under this Contract. The CPM Schedule shall be submitted for initial approval and then be updated and resubmitted monthly or more often as required in order to demonstrate contract compliance and facilitate evaluation of monthly payment requests and requests for time extension.
- I. The CPM Schedule shall consist of time scaled Network Analysis Diagram (logic diagram), a time scaled bar chart, a cost loaded schedule (computer data printout) and any other standard tabular reports as requested by Owner, all of which shall be submitted together in triplicate.
- J. Computer-Produced Schedule: The computer produced schedule shall meet all contractual requirements, such as contract duration, phasing, and phasing restraints, and cover all procurement activities, including submittals, submittals status, fabrication and delivery times, and reflect all key long lead or critical procurement activities.
- K. No on-site construction work will be permitted and no progress payments will be made by Owner until the **[preliminary 90-day] [preliminary] [project]** schedule has been submitted **[and approved]**.
- L. Ownership and Use of Float: Float is defined as the amount of time between the early and late completion dates of a scheduled activity. Float time on this Project is a project resource jointly owned by the Owner and Contractor. This resource expires as the Project progresses, and it is to be available to and consumed by the joint owners on a first-come first-served basis. If Contractor's schedule indicates a completion date for the project prior to the contractual completion date, then the time period between the two dates shall be considered as project float and shall be owned and used in accordance with this paragraph.

1.5 FORMAT

- A. Prepare computer generated network analysis system using the critical path method, as outlined in AGC – Construction Planning and Scheduling.
- B. Network Analysis Diagram: The logic diagram shall show the sequence and interdependence of activities required for complete performance of all items of work under this Contract in the time frame allowed. The diagram shall be drafted or plotted to show a continuous flow of work, from start to finish for the entire project, reading from left to right with all activities and subnets interfaced and matchlined to allow assembly as one total project schedule.
- C. Exercise sufficient care to produce a clear, legible, and accurate diagram. Activities related to specific physical areas of the project shall be grouped on the diagram for ease of understanding and simplification. Critical path activities must be clearly identified in red. The critical path shall be plotted generally along the center of the sheet with channels with increasing floats placed towards the top or bottom.

Section 01311

COST-LOADED CONSTRUCTION PROGRESS SCHEDULES

- D. Uniquely number each activity with event numbers ranging up to 9999 only. The diagram should be generally numbered in sequence; left to right, top to bottom. Activity number to be prefixed or suffixed with corresponding AIA division. Number activities in the general progressive order that they will be completed in. Allow for inserting of additional activities should further breakdown of the work be required.
- E. The Network Analysis Diagram must clearly show the Critical Path for the Project at all times.
- F. Sequence of Listings: **[The Table of Contents of this Project Manual.] [The chronological order of the start of each item of Work.] [_____].**
- G. Scale and Spacing: To provide space for notations and revisions.
- H. Sheet Size: **[Minimum [22 x 17][24 x 36] [36 x 42] [____ x ____] inches [[560 x 432] [____ x ____] mm.] [Multiples of 8 1/2 x 11 inches (216 x 280 mm).] [_____].**

1.6 CONTENT

- A. Activities: Before attempting to produce the CPM schedule, prepare a listing of activities involved. Include every activity having a possible bearing on the time required to complete the project. Submit this listing of activities and levels of detail to Owner for approval.

Show the following on each work activity in alphanumeric form:

1. Work activity number (unique number identifying the work activity).
 2. Concise description of the work activity. Activity descriptions shall be unique to an activity and understandable at the working level.
 3. Performance responsibility or trade code.
 4. Duration (in work days).
 5. Work location, descriptive of the area involved.
 6. Total float.
 7. Early start, early finish, late start, late finish.
- B. In addition to the performance of work in place, show special activities such as:
1. Interruption of utilities, delivery of Owner furnishings and equipment, special inspections, or other project phasing requirements.
 2. Testing and balancing of mechanical equipment, special testing, equipment start-up, Owner training, etc.

Section 01311

COST-LOADED CONSTRUCTION PROGRESS SCHEDULES

3. Final cleaning, punch list inspections, final inspections, demobilization.
 4. Punchlist: Show two separate activities totaling a minimum of [_____] work days for completion of punch list items and final cleanup.
 5. Weather Delays: Total weather delays for this project are [**per the General Conditions, Construction Manager at Risk**]. A [_____] work day "Planned Weather Delay" activity shall be inserted between the Contract Directed Completion Date and Scheduled Completion Date. The planned weather delays duration will be reduced by the number of actual critical path weather delays experienced at each monthly update until the activity duration reaches 0 days. Thereafter weather delays will be an excusable delay (see General Conditions, **[Article 8] [Article 9]**).
- C. Show not only the activities for actual construction work for each trade. Category of the project, but also include trade restrictions to indicate the movement of trades from one area, floor, etc. to another area, floor, etc., for trades who are performing major portions of the work under this contract.
- D. Break up the work into activities of a duration no longer than **[20]** [_____] work days each, except as to nonconstruction activities (such as procurement of materials, delivery of equipment and concrete curing) and any other activities for which the Owner may approve the showing of longer duration. The duration for Architect's approval of any required submittal, shop drawing, etc., shall not be more than **20** work days. The construction time as determined by the Construction Progress Schedule from early start to late finish for any sub-phase, phase, or the entire project shall not exceed the Contract times indicated in Contract Documents.
- E. Describe work activities such that the work is readily identifiable for assessment of completion. Activities labeled "start", "continue", or "completion" will not be allowed. All constraints will be start-finish relationships. Lead and lag tie activities will be acceptable only if the description accurately identifies such a restraint and that such restraints are realistic with respect to the schedule of the project. Partial dependencies of activities will not be permitted without approval of the Owner.
- F. The schedule shall include separate activities for both submittal and review of all required submittals. The minimum time allocated for review and return of submittals and all resubmittals shall be **[____ days] [as stated in Section] [01300]** for each submittal or resubmittal.
- G. The schedule shall incorporate all schedule constraints (phasing or sequence of construction, delivery windows for Owner furnished items, interim milestone dates, etc.) specified in the Contract Documents.
- H. The schedule shall show separate procurement activities for all specially fabricated or custom produced items of material or equipment including order, design, submittals, fabrication and delivery.
- I. Show complete sequence of construction by activity, with dates for beginning and completion of each element of construction.

Section 01311

COST-LOADED CONSTRUCTION PROGRESS SCHEDULES

- J. Identify work of **[separate stages]** **[separate floors]** and other logically grouped activities.
- K. Provide sub-schedules for each stage of Work identified in Section **[01010.] [01011.]**
- L. Provide sub-schedules to define critical portions of the entire schedule.
- M. Include conferences and meetings in schedule.
- N. Provide separate schedule of submittal dates for shop drawings, product data, and samples, including **[Owner furnished products]** **[and]** **[Products identified under Allowances]**, and dates reviewed submittals will be required from Architect/Engineer. Indicate decision dates for selection of finishes.
- O. Indicate delivery dates for **[Owner furnished products]** **[and]** **[Products identified under Allowances.]**
- P. The schedule shall allow the following minimum time periods for the startup and shakedown operation of the following systems:
- a. HVAC.
 - b. Life Safety systems **(list)**.
 - c. Elevators.
 - d. **(Other special systems as applicable)**.
- [List times]**
- Q. Cost load all work activities to a singular resource and take special care to separate the costs for labor and materials where the placement of major equipment is involved. In special cases actual invoices or back-up may be required to verify costs.
- R. The cumulative amount of all cost loaded work activities shall equal the total Contract price. Overhead and profit shall be pro-rated on all activities for the entire project length. Generate from this information cash flow curves indicating graphically the total percentage of activity dollar value scheduled to be in place for early finish, late finish, and 50% float dates. These cash flow curves will be used by the Owner to assist in determining approval or disapproval of the cost loading. In the event of disapproval, resubmit, within 10 calendar days, a corrected or adjusted cost load report in accordance with any agreements reached during the previous notification.
- S. The computer program shall summarize the value of work completed each month by way of a responsibility (trade) sort. This sort shall summarize all work by type or trade rather than by time or sequential fashion, which sort is also required. A summary of all trade work and other work by the General Contractor will, in terms of information, constitute the schedule of values to be utilized on the monthly pay request form.
- T. Mathematical Analysis: Tabulate each activity of detailed network diagrams, using calendar dates, and identify for each activity:

Section 01311

COST-LOADED CONSTRUCTION PROGRESS SCHEDULES

1. Preceding and following event numbers.
 2. Activity description.
 3. Estimated duration of activity, in maximum **[15]** [_____] day intervals.
 4. Earliest start date.
 5. Earliest finish date.
 6. Actual start date.
 7. Actual finish date.
 8. Latest start date.
 9. Latest finish date.
 10. Total and free float; float time shall accrue to the Owner and to the Owner's benefit.
 11. Monetary value of activity, keyed to Schedule of Values.
 12. Percentage of activity completed.
 13. Responsibility.
- U. Required Sorts: List activities in sorts or groups:
1. By preceding work item or event number from lowest to highest.
 2. By amount of float, then in order of early start.
 3. By responsibility in order of earliest possible start date.
 4. In order of latest allowable start dates.
 5. In order of latest allowable finish dates.
 6. Contractor's periodic payment request sorted by **[Schedule of Values listings]** **[specifications sections]**.
 7. Listing of basic input data which generates the report.
 8. Listing of activities on the critical path.
- V. Coordinate content with schedule of values specified in Section **[01019.]** [_____].

Section 01311

COST-LOADED CONSTRUCTION PROGRESS SCHEDULES

1.7 UPDATING OF SCHEDULES

- A. The CPM Schedule shall be updated monthly, or more often if required, to indicate the actual progress of the Project. Show accumulated percentage of completion of each item, and total percentage of Work completed, as of the **[first]** [_____] day of each month.
- B. The computer-produced report shall categorize areas of work behind schedule by use of thirty, sixty, and ninety day “look ahead” projections. Along with this data, the Contractor shall submit a narrative report as a part of this monthly review and update, in a form agreed upon by the Contractor and the Owner. The narrative report shall include the current status, a description of problem areas, current and anticipated delaying factors and their estimated impact on performance of other activities and completion dates, and an explanation of corrective action taken or proposed.
- C. The submittal of monthly schedule updates by the Contractor shall be a condition precedent to the making of monthly progress payments by the Owner.
- D. When the monthly update of the schedule shows negative float on any activity, the Contractor shall take some or all of the following actions at no additional cost to the Owner, unless the negative float is the result of an excusable delay:
 - a. Increase construction manpower in quantities needed to eliminate the backlog of work and put the Project back on schedule.
 - b. Increase the number of working hours per shift, shifts per working day, working days per week, or the amount of construction equipment or any combination of the foregoing which will eliminate backlog of work and put the Project back on schedule.
 - c. Reschedule activities to achieve maximum practical concurrency of accomplishment of activities and put the Project back on schedule.
- E. If the monthly update of the schedule shows completion of the Project prior to the current contractual completion date, the time between such an early completion date and the current contractual completion date shall be identified and used as project float in accordance with Subsection 1.4L of this Section 10311.

1.8 REVISIONS TO SCHEDULES

- A. Indicate progress of each activity to date of submittal, and projected completion date of each activity.
- B. Identify activities modified since previous submittal, major changes in scope, and other identifiable changes.

Section 01311

COST-LOADED CONSTRUCTION PROGRESS SCHEDULES

- C. Provide narrative report to define problem areas, anticipated delays, and impact on Schedule. Report corrective action taken, or proposed, and its effect **[including the effect of changes on schedules of separate Contractors]**.
- D. Change to the Work: With each change proposal containing a request for a time extension, Contractor shall furnish a detailed subnet and other backup information as required to support and enable ready quantitative evaluation of the request. This backup shall indicate, by event number the activities affected, activities added, or activities deleted. Both the time and money effect shall be indicated for each activity. In the event the Contractor does not furnish the required information or an agreement cannot be reached, the Owner may direct the Contractor as to the specific logic changes and/or time adjustment which shall be entered into the schedule. All changes in the work shall be reflected in the computer produced schedule and listed in a specific fashion so as to be summarized by trade sort and incorporated into the schedule of values by change order number. Major changes shall be reflected in the Network Analysis Diagram. Minor changes may be omitted from the Network Analysis Diagram provided that there is no change in time and that the Owner and Contractor are in agreement with the procedure.
1. All changes to the Contract must be approved by the Owner prior to inclusion into the Network Analysis System. Requests for time extension as related to changes to the scope of work will be reviewed in conjunction with the revised NAS, but will not be granted or rejected on that basis alone.
 2. All costs related to the production and/or revision of the Network Analysis System including but not limited to changes in the work schedule (for whatever reason), updating requirements, reproduction, and distribution shall be borne by the Contractor. These costs shall be considered to be indirect costs only, recoverable as being included in the Contractor's mark-up referenced in Conditions of the Contract.

1.9 SUBMITTALS

- A. Immediately upon receipt of Notice of Intent to Award, submit a statement to the Owner **[Construction Manager]** describing Contractor's computerized scheduling capability for review and approval. This statement shall include the following as a minimum:
1. Identification, qualifications, and experience of the members of the Contractor's scheduling staff or any consultant's staff.
 2. References of not less than two previous projects on which the Contractor or Consultant has utilized computerized CMP scheduling, which were of not less than one-half of the value of the present Contract. Owner references shall be included. Actual working examples from previous projects may be requested by Owner. Contractor's project management and supervisory personnel shall have **[] years** **[] projects** minimum experience in using and monitoring cost-loaded CPM schedules on comparable projects.

Section 01311

COST-LOADED CONSTRUCTION PROGRESS SCHEDULES

3. The name and description of the project management software and computer hardware to be utilized on this Contract.
 - B. At the preconstruction conference, Contractor shall submit the preliminary progress schedule.
 - C. Submit Interim and Final Network Diagrams in accordance with Subsection 1.4 of this Section 01311.
 - D. Participate in review of Interim and Final network diagrams jointly with Architect **Construction Manager** and Owner.
 - E. Within **[20]** **[_____]** days after joint review of Interim network diagram, submit draft of proposed Final network diagram for review. Include written certification that **[major]** **mechanical and electrical** Subcontractors have reviewed and accepted proposed schedule.
 - F. Within **[10]** **[_____]** days after joint review of proposed Final network submit complete analysis consisting of network diagrams and mathematical analysis.
 - G. The Contractor shall also submit the following logic diagram supporting data:
 1. The proposed number of working days per week.
 2. The holidays to be observed during the life of the Contract (by day, month, and year).
 3. The planned number of shifts per day.
 4. The number of hours per shift.
 5. The major construction equipment to be used on the site.
 - H. Submit updated Progress Schedules with **each** **every second** **[_____]** Application for Payment.
 - I. Submit the number of opaque reproductions which Contractor requires, plus **[two]** **[_____]** copies which will be retained by **Architect/Engineer.** **Construction Manager** **Owner** **[_____].**
- *****[OR]*****
- I. Submit **[one]** **[_____]** opaque reproduction and one reproducible transparency.
 - J. Owner may request expediting of material and equipment deliveries without assuming the responsibility for said deliveries. Upon request, furnish to the Owner copies of the equipment and material purchase orders complete with scheduled shipping and receiving dates.

Section 01311

COST-LOADED CONSTRUCTION PROGRESS SCHEDULES

1.10 DISTRIBUTION

- A. Following initial submittal to and response by Owner, print and distribute Construction Schedule to **[Construction Manager (_____ copies)]**, Owner, (_____ copies), Architect (_____ copies), subcontractors, suppliers, fabricators, and others with schedule-compliance requirements. Post copies in Project meeting rooms and field office. When revisions are made, distribute updated issues to same entities. Those who are no longer involved in performance of scheduled Work may be deleted from distribution list. Revised Schedule shall be reissued with report of Progress Meeting.

- B. Instruct recipients to promptly report, in writing, problems anticipated by projections indicated in schedules.

2 PART 2 PRODUCTS

Not Used.

3 PART 3 EXECUTION

Not Used.

END OF SECTION

Section 01400**QUALITY CONTROL**

- 1 PART 1 GENERAL
- 1.1 SECTION INCLUDES
 - A. Quality assurance – control of installation
 - B. Tolerances
 - C. Testing Services
 - D. Inspection Services
 - E. Manufacturers' field services
 - F. Workmanship
- 1.2 RELATED SECTIONS
 - A. Section 01090 – Reference Standards.
 - B. Section 01300 – Submittals.
 - C. Section 01600 – Material and Equipment.
 - D. Section 01650 – Starting of Systems.
- 1.3 QUALITY ASSURANCE – CONTROL OF INSTALLATION
 - A. Monitor quality control over suppliers, manufacturers, Products, services, site conditions, and workmanship, to produce Work of specified quality.
 - B. Comply with manufacturers' instructions, including each step in sequence.
 - C. Should manufacturers' instructions conflict with Contract Documents, request clarification from Architect/Engineer before proceeding.
 - D. Comply with specified standards as minimum quality for the Work except where more stringent tolerances, codes, or specified requirements indicate higher standards or more precise workmanship.
 - E. Perform Work by persons qualified to produce required and specified quality.
 - F. Verify that field measurements are as indicated on shop drawings or as instructed by the manufacturer.
 - G. Secure Products in place with positive anchorage devices designed and sized to withstand stresses, vibration, physical distortion, or disfigurement.

Section 01400**QUALITY CONTROL****1.4 TOLERANCES**

- A. Monitor fabrication and installation tolerance control of Products to produce acceptable Work. Do not permit tolerances to accumulate.
- B. Comply with manufacturers' tolerances. Should manufacturers' tolerances conflict with Contract Documents, request clarification from Architect/Engineer before proceeding.
- C. Adjust Products to appropriate dimensions; position before securing Products in place.

1.5 TESTING SERVICES

- A. Owner will appoint, employ, and pay for specified services of an independent firm to perform testing. Employment of testing agency or laboratory in no way relieves Contractor of obligation to perform Work in accordance with requirements of Contract Documents.
- B. The independent firm will perform tests and other services specified in individual specification sections and as required by the Architect/Engineer or Authority Having Jurisdiction.
- C. Testing and source quality control may occur on or off the project site. Perform off-site testing as required by the Architect/Engineer or the Owner.
- D. Reports will be submitted by the independent firm to the Architect/Engineer, Owner and Contractor, in duplicate indicating observations and results of tests and indicating compliance or non-compliance with Contract Documents.
- E. Cooperate with independent firm; furnish samples of materials, design mix, equipment, tools, storage, safe access, and assistance by incidental labor as requested.
 - 1. Notify Architect/Engineer and independent firm 24 hours prior to expected time for operations requiring services.
 - 2. Make arrangements with independent firm and pay for additional samples and tests required for Contractor's use.
- F. Re-testing required because of non-conformance to specified requirements shall be performed by the same independent firm on instructions by the Architect/Engineer. Payment for re-testing will be charged to the Contractor by deducting testing charges from the Contractor's Payment Application.
- G. Limits of testing authority are as follows:
 - 1. Independent firm may not release, revoke, alter, or enlarge on requirements of Contract Documents.

Section 01400

QUALITY CONTROL

- 2. Independent firm may not approve or accept any portion of the Work.
 - 3. Independent firm may not assume any duties of Contractor.
 - 4. Independent firm has no authority to stop the Work.
- H. Testing requirements are specified in the individual specification section for the Work requiring tests.

1.6 INSPECTION SERVICES

- A. Owner will perform its inspection services utilizing either its own employees or independent firms, or both.
- B. The independent firm(s) will perform inspections and other services as specified in individual specification sections or required by the Owner.
- C. Inspection may occur on or off the project site. Off-site inspection will be performed as required by the Architect/Engineer or the Owner.
- D. Reports will be submitted to the Architect/Engineer, Owner, and Contractor, in duplicate, indicating inspection observations and indicating compliance or non-compliance with Contract Documents.
- E. Cooperate with inspectors; furnish safe access and assistance by incidental labor as request. Notify Architect/Engineer and independent firm 24 hours prior to expected time for operations requiring services.
- F. Inspection of Work in no way relieves Contractor of obligation to perform Work in accordance with requirements of Contract Documents.
- G. Re-inspection required because of non-conformance to specified requirements shall be performed by the same inspector(s). Payment for re-inspection will be charged to the Contractor by deducting re-inspection charges from the Contractor's Payment Application.
- H. Limits of inspection authority are as follows:
 - 1. Inspections may not release, revoke, alter, or enlarge on requirements of Contract Documents.
 - 2. Inspectors may not approve or accept any portion of the Work.
 - 3. Inspectors may not assume any duties of Contractor.
 - 4. Inspectors have no authority to stop the Work.
- I. Inspection requirements are specified in the individual specification section for the Work requiring inspection.

Section 01400

QUALITY CONTROL

1.7 MANUFACTURERS' FIELD SERVICES

- A. When specified in individual specification sections, require material or product suppliers or manufacturers to provide qualified staff personnel to observe site conditions, conditions of surfaces and installation, quality of workmanship, start-up of equipment, test, adjust and balance of equipment, as applicable, and to initiate instruction when necessary.
- B. Submit qualifications of observer to Architect/Engineer 30 days in advance of required observations.
- C. Report observations and site decisions or instructions given to applicators or installers that are supplemental or contrary to manufacturers' written instructions.
- D. Refer to Section 01300 – SUBMITTALS, MANUFACTURERS' FIELD REPORTS article.

1.8 WORKMANSHIP

- A. Owner will observe Contractors performance relating to workmanship and shall have authority to direct Contractor to instigate and maintain procedures to ensure that persons performing work at site are skilled and knowledgeable in methods and craftsmanship needed to produce required quality in completed work. Contractor shall remove and replace persons and work which does not comply with workmanship standards specified and as recognized in the construction industry for applications indicated and shall remove and replace other work damaged or deteriorated by faulty workmanship or its replacement.

2 PRODUCTS

Not Used.

3 EXECUTION

3.1 EXAMINATION

- A. Verify that existing site conditions and substrate surfaces are acceptable for subsequent Work. Beginning new Work means acceptance of existing conditions.
- B. Verify that existing substrate is capable of structural support or attachment of new Work being applied or attached.
- C. Examine and verify specific conditions described in individual specification sections.
- D. Verify that utility services are available, of the correct characteristics, and in correct locations.

3.2 PREPARATION

Section 01400

QUALITY CONTROL

- A. Clean substrate surfaces prior to applying next material or substance.
- B. Seal cracks or openings of substrate prior to applying next material or substance.
- C. Apply manufacturer required or recommended substrate primer, sealer, or conditioner prior to applying any new material or substance in contact or bond.

END OF SECTION

Section 01500

CONSTRUCTION FACILITIES AND TEMPORARY CONTROLS

1 PART 1 GENERAL

1.1 SECTION INCLUDES

- A. Temporary Utilities: **[Electricity,] [lighting,] [heat,] [cooling,] [ventilation,] [communication services,] [water,] [and] [sanitary facilities].**
- B. Temporary Controls: **[Barriers,] [enclosures and fencing,] [protection of the Work,] [surface water control,] [dust control,] [erosion and sediment control,] [and] [noise control].**
- C. Construction Facilities: **[Access roads,] [parking,] [progress cleaning,] [and] [temporary buildings].**

1.2 RELATED SECTIONS

- A. Section 01540 – Security.
- B. Section 01561 – Construction Cleaning.
- C. Section 01580 – Project Identification and Signs.
- D. Section 01590 – Field Offices and Sheds.
- E. Section 01700 – Contract Closeout: Final cleaning.

1.3 TEMPORARY ELECTRICITY

- A. Cost: By Contractor; provide and pay for power service required from **Tucson Electric Power Company**. Source shall be **[location of pole.]**

*****[OR]*****

- B. Cost: By Owner; connection to Owner's existing power service. Do not disrupt Owner's need for continuous service. **[Owner will pay cost of energy used. Exercise measures to conserve energy.]**

*****[OR]*****

- C. Cost: By Contractor; connect to Owner's existing power service. Do not disrupt Owner's need for continuous service.

- 1. Provide temporary electric feeder from **[existing building]** electrical service at **[location as directed]**. Provide an electric utility meter at this location. Owner will read the meter on a monthly basis and directly invoice the contractor for reimbursement. Do not disrupt Owner's need for continuous service.

Section 01500

CONSTRUCTION FACILITIES AND TEMPORARY CONTROLS

- D. **[Power] [Feeder]** Service Characteristics: [_____] volt, [_____] ampere, **[three]** [_____] phase, **[four]** [_____] wire.Com.

*****[OR]*****

- D. Complement existing power service capacity and characteristics as required.
- E. Provide power outlets for construction operations, with branch wiring and distribution boxes located **[at each floor.] [as required.]** [_____] Provide flexible power cords as required.
- F. Provide **[main service disconnect and over-current protection at convenient location.] [feeder switch at source distribution equipment.]**
- G. Permanent convenience receptacles may **[not]** be utilized during construction.
- H. Remove the temporary installation and connections of systems when no longer required. Restore the services sources and supply to proper operating condition.
- I. Provide protection for each power supply source complete with disconnect switches and other required electrical devices.

1.4 TEMPORARY LIGHTING FOR CONSTRUCTION PURPOSES

- A. Provide and maintain lighting for construction operations to achieve a minimum lighting level of **[2] [_____] watt/sq. ft.**
- B. Provide and maintain **[1] [_____] watt/sq. ft** lighting to exterior staging and storage areas after dark for security purposes.
- C. Provide and maintain **[0.25] [_____] watt/sq. ft** H.I.D. lighting to interior work areas after dark for security purposes.
- D. Provide branch wiring from power source to distribution boxes with lighting conductors, pigtails, and lamps as required.

*****[OR]*****

- D. Maintain lighting and provide routine repairs.
- E. Permanent building lighting may **[not]** be utilized during construction.

1.5 TEMPORARY HEATING

- A. Provide heating devices and heat as needed to maintain specified conditions for construction operations.
- B. Prior to operation of permanent equipment for temporary heating purposes, verify that installation is approved for operation, equipment is lubricated and filters are in

Section 01500

CONSTRUCTION FACILITIES AND TEMPORARY CONTROLS

- place. Provide and pay for operation, maintenance, and regular replacement of filters and worn or consumed parts.
- C. Maintain minimum ambient temperature of 50 degrees F in areas where construction is in progress, unless indicated otherwise in product sections.
- 1.6 TEMPORARY COOLING
- A. Provide cooling devices and cooling as needed to maintain specified conditions for construction operations.
- B. Prior to operation of permanent equipment for temporary cooling purposes, verify that installation is approved for operation, equipment is lubricated and filters are in place. Provide and pay for operation, maintenance, and regular replacement of filters and worn or consumed parts.
- C. Maintain maximum ambient temperature of 80 degrees F in areas where construction is in progress, unless indicated otherwise in specifications.
- 1.7 TEMPORARY VENTILATION
- A. Ventilation enclosed areas to achieve curing of materials, to dissipate humidity, and to prevent accumulation of dust, fumes, vapors, or gases. Comply with IAQ Guidelines for Occupied Buildings Under Construction.
- B. Utilize existing ventilation equipment. Extend and supplement equipment with temporary fan units as required to maintain clean air for construction operations.
- 1.8 COMMUNICATION SERVICES
- A. Arrange for all of the following services through Owner's Communications (CCIT) Department.
- B. TELEPHONE SERVICE
1. Provide, maintain, and pay for telephone service to field office **[and Architect/Engineer's field office]** at time of project mobilization.
 2. Architect/Engineer will pay for own service.
- C. FACSIMILE SERVICE
1. Provide, maintain and pay for facsimile service **[and a dedicated telephone]** to field office **[and Architect/Engineer's field office]** at time of project mobilization.
 2. Architect/Engineer will pay for own service.
- D. DATA (COMPUTER) SERVICE

Section 01500

CONSTRUCTION FACILITIES AND TEMPORARY CONTROLS

1. Provide, maintain and pay for data service **[and a dedicated telephone]** to field office **[and Architect/Engineer's field office]** at time of project mobilization.
2. Architect/Engineer will pay for own service.
3. Provide scanning capability up to 11" x 17" size minimum.

1.9 TEMPORARY WATER SERVICE

- A. **[Provide, maintain and pay for suitable quality water service required]**
[Connect to existing water source] for construction operations at time of project mobilization.
- B. **[Owner will pay cost of water used. Exercise measures to conserve water.]**
- C. Extend branch piping with outlets located so water is available by hoses with threaded connections. **[Provide temporary pipe insulation to prevent freezing.]**

1.10 TEMPORARY SANITARY FACILITIES

- A. Provide and maintain required facilities and enclosures. **[Existing facility use is not permitted.]** Provide at time of project mobilization.

*****[OR]*****

- B. **[Existing]** **[Permanent]** **[Designated]** facilities **[located at [_____]]** may be used during construction operations. Maintain daily in clean and sanitary condition equivalent to Owner's maintenance.
- C. At end of construction, return facilities to same or better condition as originally found.

1.11 BARRIERS

- A. Provide barriers to prevent unauthorized entry to construction areas and to protect existing facilities and adjacent properties from damage from construction operations.
- B. Provide barricades and covered walkways required by governing authorities for public right-of-ways **[and for public access to existing building]**.
- C. Provide protection for plants designated to remain. Replace damaged plants.
- D. Protect non-owned vehicular traffic, stored materials, site, and structures from damage.

1.12 FENCING

Section 01500

CONSTRUCTION FACILITIES AND TEMPORARY CONTROLS

- A. Exterior work and storage areas exposed to adjacent pedestrian traffic or which present an attractive nuisance shall at all times be satisfactorily fenced and secured with chain link fence panels.
- B. Construction: **[Commercial grade chain link fence.]** Associated support posts are to be driven or anchored into the ground, concrete or asphalt. T-posts are to be avoided.
- C. Provide 6 foot high fence around construction site; equip with vehicular **[and pedestrian]** gates with locks.
- D. When the hazard/nuisance to pedestrian traffic is minimal and subject to the approval of the Architect and Owner, temporary, short term fencing needs may be accomplished with plastic roll fencing and flagging.

1.13 SURFACE WATER CONTROL

- A. Grade site to drain. Maintain excavations free of water. Provide, operate, and maintain pumping equipment.
- B. Protect site from puddling or running water. **[Provide water barriers as required to protect site from [soil erosion] [_____].]**
- C. Provide temporary measures such as berms, dikes and drainage ways to prevent water flow from damaging the Work or adjacent property.

1.14 EXTERIOR ENCLOSURES

- A. Provide temporary **[insulated]** weather tight closure of exterior opening to accommodate acceptable working conditions and protection for Products, to allow for temporary heating and maintenance of required ambient temperatures identified in individual specification sections, and to prevent entry of unauthorized persons. Provide access doors with self-closing hardware and locks.
- B. If exterior work on or above new roof level is not complete by the time of dry-in for start of interior work, provide temporary roofing as specified in Section [_____].

1.15 INTERIOR ENCLOSURES

- A. Provide temporary partitions **[and ceilings]** as indicated to separate work areas from Owner occupied areas, to prevent penetration of dust and moisture into Owner occupied areas, and to prevent damage to existing materials and equipment.
- B. Construction: Framing and **[reinforced polyethylene] [plywood] [gypsum board]** sheet materials with closed joints and sealed edges at intersections with existing surfaces.
 - 1. Insulated to R [_____] (RS) [_____].

Section 01500

CONSTRUCTION FACILITIES AND TEMPORARY CONTROLS

2. STC rating of [**35**] [_____] in accordance with ASTM E90.
 3. Maximum flame spread rating of [**75**] [**25**] in accordance with ASTM E84.
- C. Paint surfaces exposed to view from Owner occupied areas.
- 1.16 PROTECTION OF INSTALLED WORK
- A. Protect installed Work and provide special protection where specified in individual specification sections.
 - B. Provide temporary and removable protection for installed Products. Control activity in immediate work area to prevent damage.
 - C. Provide protective coverings at walls, projections, jambs, sills, and soffits of openings.
 - D. Protect finished floors, stairs, and other surfaces from traffic, dirt, wear, damage, or movement of heavy objects, by protecting with durable sheet materials.
 - E. Prohibit traffic or storage upon waterproofed or roofed surfaces. If traffic or activity is necessary, obtain recommendations for protection from waterproofing or roofing material manufacturer.
 - F. Prohibit traffic from landscaped areas.
- 1.17 DUST CONTROL
- A. Execute Work by methods to minimize raising dust from construction operations.
 - B. Provide positive means to prevent air-borne dust from dispersing into atmosphere.
 - C. When dust-generated work is performed in the vicinity of active fire alarm devices, temporary fire alarm bypasses will be required.
- 1.18 EROSION AND SEDIMENT CONTROL
- A. Plan and execute construction by methods to control surface drainage from cuts and fills, from borrow and waste disposal areas. Prevent erosion and sedimentation. Provide soil and erosion control plan as required by Pima County Department of Environmental Quality.
 - B. Minimize amount of bare soil exposed at one time.
 - C. Provide temporary measures such as berms, dikes, and drains, to prevent water flow.

Section 01500

CONSTRUCTION FACILITIES AND TEMPORARY CONTROLS

- D. Construct fill and waste areas by selective placement to avoid erosive surface silts or clays.
- E. Periodically inspect earthwork to detect evidence of erosion and sedimentation; promptly apply corrective measures.

1.19 NOISE CONTROL

- A. Provide methods, means, and facilities to minimize noise from [_____] and noise produced by construction operations.
- B. The Contractor shall comply with all local sound control and noise level rules, regulations and ordinances, which apply to any work performed pursuant to the contract including excavation, hauling and dumping.
- C. Haul trucks and equipment shall be maintained and operated in such a manner so as to minimize the generation of noise. The Owner reserves the right to review the operation of this equipment throughout the haul route to insure that no unnecessary noise is generated. The Contractor will be required to remedy any unsatisfactory conditions. In no case will the use of engine compression brakes be permitted.

1.20 ACCESS ROADS

- A. Construct and maintain temporary roads accessing public thoroughfares to serve construction area.
- B. Extend and relocate as Work progress requires. Provide detours necessary for unimpeded traffic flow.
- C. Provide and maintain access to fire hydrants, free of obstructions.
- D. Provide means of removing mud from vehicle wheels before entering streets.
- E. **[Designated]** existing on-site roads **[may] [shall not]** be used for construction traffic.

1.21 PARKING

- A. Parking of Contractor's vehicles and vehicles of the Contractor's employees, shall be only at locations designated by the Owner. The available space for Contractor parking will be verified at the Pre-Construction Conference. The location will be as close to the construction site as possible.
- B. Vehicle spaces will be limited in number, and the vehicles must have permits properly displayed. The Contractor may apply to the parking Service Field Coordinator at 621-3756 for permits to park on campus.
- C. If granted, the costs for these permits will be borne by the Contractor. The permits are transferable and are valid for one year with the unused portion being refundable. Verify costs and all conditions with the Owner.

Section 01500

CONSTRUCTION FACILITIES AND TEMPORARY CONTROLS

- D. If a vehicle is permitted and parked in unauthorized space, a citation will be issued. If vehicle does not display permit, a citation will be issued.

1.22 PROGRESS CLEANING AND WASTE REMOVAL

- A. Maintain areas free of waste materials, debris, and rubbish. Maintain site in a clean and orderly condition.
- B. Remove debris and rubbish from pipe chases, plenums, attics, crawl spaces, and other closed or remote spaces, prior to enclosing the space.
- C. Broom and vacuum clean interior areas prior to start of surface finishing, and continue cleaning to eliminate dust.
- D. Collect and remove waste materials, debris, and rubbish from site **[weekly]** **[_____]** and dispose off-site.
- E. Open free-fall chutes are not permitted. Terminate closed chutes into appropriate containers with lids.

1.23 FIELD OFFICES AND SHEDS

- A. Office: Weather tight, with lighting, electrical outlets, heating, cooling, **[and]** **[ventilating]** equipment, and equipped with sturdy furniture, drawing rack, and drawing display table.
- B. Provide space for Project meetings, with table and chairs to accommodate 12 persons.
- C. Provide separate private office, similarly equipped and furnished, for use of **[Architect/Engineer]** **[Owner]**.
- D. Locate offices and sheds as directed.

1.24 REMOVAL OF UTILITIES, FACILITIES, AND CONTROLS

- A. Remove temporary utilities, equipment, facilities, materials, prior to Final Acceptance inspection.
- B. Remove underground installations. **[Grade site as indicated.]**
- C. Clean and repair damage caused by installation or use of temporary work.
- D. Restore existing **[and permanent]** facilities used during construction to original condition. **[Restore permanent facilities used during construction to specified condition.]**

DIVISION 1

UA No.

Section 01500

CONSTRUCTION FACILITIES AND TEMPORARY CONTROLS

2 PART 2 PRODUCTS

Not Used.

3 PART 3 EXECUTION

Not Used.

END OF SECTION

Section 01510

TEMPORARY UTILITIES

1 PART 1 GENERAL

1.1 SECTION INCLUDES

- A. Temporary Utilities: **[Electricity.] [Lighting.] [Heat.] [Ventilation.],
Telephone service.] [Water.] [and] [Sanitary facilities]**

1.2 RELATED SECTIONS

- A. Section 01555 – Construction Facilities
- B. Section 01560 – Temporary Controls
- C. Section 01570 – Traffic Regulation
- D. Section 01580 – Project Identification and Signs
- E. Section 01590 – Field Offices and Sheds.
- F. Section 01700 – Contract Closeout: Final cleaning

1.3 TEMPORARY ELECTRICITY

- A. Cost: By Contractor; provide and pay for power service required from **Tucson Electric Power Company**. Source shall be **[location of pole.]**

*****[OR]*****

- B. Cost: By Owner; connection to Owner's existing power service. Do not disrupt Owner's need for continuous service. **[Owner will pay cost of energy used. Exercise measures to conserve energy.]**

*****[OR]*****

- C. Cost: By Contractor; connect to Owner's existing power service. Do not disrupt Owner's need for continuous service.
1. Provide temporary electric feeder from **[existing building]** electrical service at **[location as direct]**. Provide an electric utility meter at this location. Owner will read the meter on a monthly basis and directly invoice the contractor for reimbursement. Do not disrupt Owner's need for continuous service.
- D. **[Power] [Feeder]** Service Characteristics: **[_____]** volt, **[_____]** ampere, **[three]** **[_____]** phase, **[four]** **[_____]** wire.Com

*****[OR]*****

- G. Complement existing power service capacity and characteristics as required.

Section 01510

TEMPORARY UTILITIES

- H. Provide power outlets for construction operations, with branch wiring and distribution boxes located **[at each floor.] [as required.] [_____.]**
Provide flexible power cords as required.
- I. Provide **[main service disconnect and over-current protection at convenient location.] [feeder switch at source distribution equipment.]**
- J. Permanent convenience receptacles may **[not]** be utilized during construction.
- K. Remove the temporary installation and connections of systems when no longer required. Restore the services sources and supply to proper operating condition.
- L. Provide protection for each power supply source complete with disconnect switches and other required electrical devices.
- M. Submit sealed electrical diagram and one-line drawing of temporary service for Owner approval.

1.4 TEMPORARY LIGHTING FOR CONSTRUCTION PURPOSES

- A. Provide and maintain **[incandescent]** lighting for construction operations **[to achieve a minimum lighting level of [2] [____] watt/sq ft].**
- B. Provide and maintain **[1]** watt/sq ft lighting to exterior staging and storage areas after dark for security purposes.
- C. Provide and maintain **[0.25]** watt/sq ft H.I.D. lighting to interior work areas after dark for security purposes.
- D. Provide branch wiring from power source to distribution boxes with lighting conductors, pigtails, and lamps as required.
- E. Maintain lighting and provide routine repairs.
- F. Permanent building lighting may **[not]** be utilized during construction.
- G. Exterior fixtures over 50 watts shall be fully shielded per City of Tucson Lighting Ordinance.
- H. Exterior lamp sources over 50 watts shall not be metal halide.
- I. All HID fixtures shall be totally enclosed with safety chains and tempered glass lenses.

1.5 TEMPORARY HEATING

- A. Existing facilities shall not be used.

*****[OR]*****

- B. Provide **and pay for** heating devices and heat as needed to maintain specified conditions for construction operations.

*****[OR]*****

- C. Utilize Owner's **existing** **new** heat plant, extend and supplement with temporary heat devices as needed to maintain specified conditions for construction operations.
- D. **Owner will pay cost of energy used. Exercise measures to conserve energy.** **Provide separate metering and reimburse Owner for cost of energy used.**
- E. **Enclose building prior to activating temporary heat in accordance with the Exterior Enclosures article in this section.**
- F. Prior to operation of permanent equipment for temporary heating purposes, verify that installation is approved for operation, equipment is lubricated and filters are in place. Provide and pay for operation, maintenance, and regular replacement of filters and worn or consumed parts.
- G. Maintain maximum ambient temperature of **50** degrees F(**10** degrees C) in areas where construction is in progress, unless indicated otherwise in specifications.
- H. When it has been determined by mutual agreement between the Contractor and the Architect, in writing, that the temporary heating is no longer required, remove all temporary piping, temporary heating units and other equipment.

1.6 TEMPORARY COOLING

- A. Existing facilities shall not be used.

*****[OR]*****

- B. Provide **and pay for** cooling devices and cooling as needed to maintain specified conditions for construction operations.

*****[OR]*****

- C. Utilize Owner's **existing** **new** cooling plant, extend and supplement with temporary cooling devices as needed to maintain specified conditions for construction operations.
- D. **Owner will pay cost of energy used. Exercise measures to conserve energy.** **Provide separate metering and reimburse Owner for cost of**

Section 01510

TEMPORARY UTILITIES

energy used.] [Enclose building prior to activating temporary cooling in accordance with the Exterior Enclosures article in this section.]

- E. Prior to operation of permanent equipment for temporary cooling purposes, verify that installation is approved for operation, equipment is lubricated and filters are in place. Provide and pay for operation, maintenance, and regular replacement of filters and worn or consumed parts.
- F. Maintain maximum ambient temperature of **[80] []** degrees F (**[26] []** **degrees C**) in areas where construction is in progress, unless indicated otherwise in specifications.

1.7 TEMPORARY VENTILATION

- A. Ventilate enclosed areas to assist cure of materials, to dissipate humidity, and to prevent accumulation of dust, fumes, vapors, or gases.
- B. Utilize existing ventilation equipment. Extend and supplement equipment with temporary fan units as required to maintain clean air for construction operations.

1.8 TELEPHONE AND DATA SERVICE

- A. Provide, maintain, and pay for telephone service to field office **[and Architect/Engineer's field office]** at any time of project mobilization.
- B. **[Architect/Engineer will pay for own service]**

1.9 FACSIMILE SERVICE

- A. Provide, maintain and pay for facsimile service **[and a dedicated telephone line]** to field office **[and Architect/Engineer's field office]** at time of project mobilization
- A. Provide, maintain, and pay for dedicated connection to University's data service from Field Office at time of project. Coordinate installation requirements with University CCIT Department.
- B. **[Provide for telephone/and data outlet at Owner and Architect/Engineer plan table. Refer to Section 01590.]**

1.10 TEMPORARY WATER SERVICE

- A. **[Provide, maintain and pay for suitable quality water service required]** **[Connect to existing water source]** for construction operations at time of project mobilization

Section 01510

TEMPORARY UTILITIES

- B. Owner will pay cost of water used. Exercise measures to conserve water. Provide separate metering and reimburse Owner for cost of water used.
- C. Extend branch piping with outlets located so water is available by hoses with threaded connections. Provide temporary pipe insulation to prevent freezing.

1.11 TEMPORARY SANITARY FACILITIES

- A. Provide and maintain required facilities and enclosures. Existing facility use is not permitted. Provide at time of project mobilization.

*****[OR]*****

- A. Existing Permanent designated facilities located at [_____] may be used during construction operations. Maintain daily in clean and sanitary condition.
- B. At end of construction, return facilities to same or better condition as originally found.

2 PART 2 PRODUCTS
Not Used

3 PART 3 EXECUTION
Not Used

END OF SECTION

1 PART 1 GENERAL

1.1 SECTION INCLUDES

- A. Security program
- B. Entry control.
- C. Building Access.

1.2 RELATED SECTIONS

- A. Section **[01010 – Summary of Work:] [Contractor use of premises.] [Owner occupancy].**
- B. Section 01500 – Construction Facilities and Temporary Controls.

1.3 SECURITY PROGRAM

- A. Protect Work **[existing premises] [and] [Owner's operations]** from theft, vandalism, and unauthorized entry.
- B. Initiate program **[in coordination with Owner's existing security system]** at project mobilization.
- C. Maintain program throughout construction period until **[Owner occupancy.] [Owner acceptance precludes the need for Contractor security.] [directed by Architect/Engineer.]**

1.4 ENTRY CONTROL

- A. Restrict entrance of persons and vehicles into Project site **[and existing facilities].**
- B. Allow entrance only to authorized persons with proper identification.
- C. Maintain log of workers and visitors, make available to Owner on request
- D. **[Owner will] [Contractor shall]** control entrance of persons and vehicles related to Owner's operations.

*****[OR]*****

- E. Coordinate access of Owner's personnel to site in coordination with Owner's security forces.

DIVISION 1

UA No.

Section 01540

SECURITY

1.5 BUILDING ACCESS

- A. If in order to execute the work it becomes necessary to issue keys to the Contractor, a deposit of \$50.00 will be required for each key so issued. Deposits will be returned to the Contractor upon the return of the keys to the University.
- B. In the event that a key is lost and is not returned to the University, thereby breaching the security of the building(s), the deposit shall be forfeited, and in addition, the Contractor shall be held liable for the cost of re-keying of the building(s) by the Owner.
- C. Where keyless access systems are in place, Contractor and subcontractors will be authorized to purchase Owner's "Cat cards" at a cost of \$15 each for building access in lieu of keys.

2 PRODUCTS

Not Used.

3 EXECUTION

Not Used.

END OF SECTION

Issued October 2003

1 PART 1 GENERAL

1.1 SECTION INCLUDES

- A. Access roads.
- B. Maintenance.
- C. Removal, repair.
- D. Mud from site vehicles.
- E. Haul Routes
- F. Hauling Restrictions/Load Requirements

1.2 RELATED SECTIONS

- A. Section 01010 – Summary of Work.
- B. Section 01039 – Coordination and Meetings.
- C. Section 01555 – Construction Facilities
- D. Section 01560 - Temporary Controls.
- E. Section 01570 – Traffic Regulation.
- F. Section 02200– Earthwork.

2 PART 2 PRODUCTS

2.1 MATERIALS

- A. Temporary Construction: Contractor's option.
- B. Earthwork, Paving Base, and Topping which will all become part of permanent construction as specified in product specification sections.

3 PART 3 EXECUTION

3.1 PREPARATION

- A. Clear areas, provide surface and storm drainage of road, parking, area premises, and adjacent areas.

Section 01550

ACCESS ROADS

3.2 ACCESS ROADS

- A. Construct and maintain temporary access roads from public thoroughfares to serve construction area, of a width and load bearing capacity to provide unimpeded traffic for construction purposes.
- B. Extend and relocate as Work progress requires, provide detours as necessary for unimpeded traffic flow.
- C. Provide unimpeded access for emergency vehicles. Maintain 20 foot width driveways with turning space between and around combustible materials.
- D. Provide and maintain access to fire hydrants and control valves free of obstructions.

3.3 MAINTENANCE

- A. Maintain traffic and parking areas in a sound condition free of excavated material, construction equipment, Products, mud, snow, and ice.
- B. Maintain existing and permanent paved areas used for construction; promptly repair breaks, potholes, low areas, standing water, and other deficiencies, to maintain paving and drainage in original, or specified, condition.

3.4 REMOVAL, REPAIR

- A. Remove temporary materials and construction before Substantial Completion.
- B. Remove underground work and compacted materials to a depth of 2 feet, fill and grade site as specified.
- C. Repair permanent facilities damaged by use, to specified condition.

3.5 MUD FROM SITE VEHICLES

- A. Provide means of removing mud from vehicle wheels before entering streets.

3.6 HAUL ROUTES

- A. The Contractor is to coordinate with the Owner and secure approval from the City of Tucson; Traffic Engineering regarding haul routes and schedules on public roads.
- B. **[Supplemental traffic control by an off-duty Traffic Control Officer will be required during night work. The Traffic Control Officer will control the signal at [] and [] during times when that access is used.]**
- C. Traffic control plans and schedules shall be submitted to the Owner and reviewed and approved by the City of Tucson; Traffic Engineering.

Section 01550**ACCESS ROADS**

- D. Residential streets are not to be used. Any public street damages by the Contractor's vehicles or operation shall be repaired by the Contractor at no expense to the Owner.

3.7 HAULING RESTRICTIONS/LOAD REQUIREMENTS

- A. The Contractor shall comply with all legal load restrictions in the hauling of materials on public roads. A pamphlet, Sizes and Weights of Vehicles and Loads upon Highways, which has been extracted from Title 28, Chapter 6, Arizona Revised Statutes, is available from the Motor Vehicle Division, Arizona Department of Transportation. A special permit shall not relieve the Contractor of liability for damage, which may result from hauling of material or moving of equipment.
- B. The operation of equipment of such weight or so loaded as to cause damage to structures or the roadway or to any other type of construction shall not be permitted. The Contractor shall be responsible for all damage done by the Contractor's hauling equipment. In no case shall legal load limits be exceeded unless permitted, in writing, by the City of Tucson Traffic Engineer.
- C. Hauling of materials over the subgrade or the base course or surface course under construction shall be limited as directed by the Architect. No loads shall be permitted on a portland cement concrete pavement, base or structure before the expiration of the curing period.
- D. City of Tucson Requirements:
 - 1. The applicant must furnish to the City of Tucson Traffic Engineering proof that the University was notified prior to any approval of haul route.
 - 2. The applicant and its subcontractors are responsible for traffic control. It is their responsibility to periodically examine barricades, traffic control devices, and warning signs to insure they meet all federal and city requirements.
 - 3. The applicant is responsible for continually cleaning the entrance, egress, and roadway of the haul route of excess dirt and debris.
 - 4. The University is responsible for notifying businesses and residences affected by the egress and entrance of haul routes.
 - 5. The normal days and hours of haul route operations are Monday through Friday, 7:00 p.m. to 6:00 a.m. Weekend operation requires a variance from Traffic Engineering. Traffic Engineering may grant a variance if the applicant makes a request 24 hours in advance with written proof that the University was previously notified.
 - 6. Off-duty police officers or Traffic Control Officers shall be employed and utilized during all hauling operations.

DIVISION 1

UA No.

Section 01550

ACCESS ROADS

7. All work site personnel in or along the roadway are required to wear a clean reflective vest that meets federal and city standards.
8. The applicant shall meet all special conditions that may be set by Traffic Engineering during the course of haul route operation.
9. In addition, the applicant shall meet all necessary federal, state, county, and city requirements that apply to haul route operation.
10. The City of Tucson Traffic Engineering reserves the right to alter any requirement or specify additional requirement(s) during the course of the haul route operation.

END OF SECTION

Section 01555

CONSTRUCTION FACILITIES

1 PART 1 GENERAL

1.1 SECTION INCLUDES

- A. Construction Facilities: progress cleaning and removal of utilities, facilities, and controls

1.2 RELATED SECTIONS

- A. Section 01510 – Temporary Utilities.
- B. Section 01550 – Access Roads
- C. Section 01560 – Temporary Controls.
- D. Section 01570 – Traffic Regulation.
- E. Section 01590 – Field Offices and Sheds.
- F. Section 01700 – Contract Closeout: Final cleaning.

1.3 PROGRESS CLEANING AND WASTE REMOVAL

- A. Maintain areas free of waste materials, debris, and rubbish. Maintain site in a clean and orderly condition.
- B. Remove debris and rubbish from pipe chases, plenums, attics, crawl spaces, and other closed or remote spaces, prior to enclosing the space.
- C. Broom and vacuum clean interior areas prior to start of surface finishing, and continue cleaning to eliminate dust.
- D. Collect and remove waste materials, debris, and rubbish from site periodically and dispose off-site.
- E. Open free-fall chutes are not permitted. Terminate closed chutes into appropriate containers with lids.

1.4 REMOVAL OF UTILITIES, FACILITIES, AND CONTROLS

- A. Remove temporary utilities, equipment, facilities, and materials prior to Substantial Completion inspection.
- B. Remove underground installations to minimum depth of 2 feet (600 mm). Grade site as indicated.
- C. Clean and repair damage caused by installation or use of temporary work.

Section 01555

CONSTRUCTION FACILITIES

D. Restore existing facilities used during construction to original condition. Restore permanent facilities used during construction to specified condition.

2 PART 2 PRODUCTS

Not Used.

3 PART 3 EXECUTION

Not Used

END OF SECTION

Section 01560

TEMPORARY CONTROLS

- 1 PART 1 GENERAL
- 1.1 SECTION INCLUDES
 - A. Barriers
 - B. Fencing
 - C. Surface water control
 - D. Interior Enclosures
 - E. Protection of Installed Work
 - F. Security
 - G. Erosion and Sediment Control,
 - H. Noise Control
- 1.2 RELATED SECTIONS
 - A. Section 01010 – Summary of Work
 - B. Section 01039 – Coordination and Meetings
 - C. Section 01555 – Construction Facilities
 - D. Section -01561 – Construction Cleaning: Pollution and Dust Control
 - E. Section 02900 – Plant Protection
- 1.3 BARRIERS
 - A. Provide barriers to prevent unauthorized entry to construction areas but to allow for Owner's use of site and to protect existing facilities and adjacent properties from damage from construction operations and demolition.
 - B. Provide barricades and covered walkways required by governing authorities for public rights-of-way and for public access to existing buildings.
 - C. Protect non-owned vehicular traffic, stored materials, site, and structures from damage.
- 1.4 FENCING
 - A. Exterior work and storage areas exposed to adjacent pedestrian traffic or which present an attractive nuisance shall at all times be satisfactorily fenced and secured.
 - B. Construction: Commercial grade chain link fence

Section 01560

TEMPORARY CONTROLS

- C. Provide 6 foot high fence around construction site; equip with vehicular gates with locks.
- D. When the hazard/nuisance to pedestrian traffic is minimal and subject to the approval of the Architect and the Owner, temporary short term fencing needs may be accomplished with plastic roll fencing and flagging.

1.5 SURFACE WATER CONTROL

- A. Grade site to drain. Maintain excavations free of water. Provide, operate, and maintain pumping equipment.
- B. Protect site from puddling or running water. Provide water barriers as required to protect site from soil erosion and flooding.

1.6 INTERIOR ENCLOSURES

- A. Provide temporary partitions and ceilings as indicated to separate work areas from Owner occupied areas, to prevent penetration of dust and moisture into Owner occupied areas, and to prevent damage to existing materials and equipment.
- B. Construction: Framing and gypsum board sheet materials with closed joints and sealed edges at intersections with existing surfaces:

STC rating of 35 in accordance with ASTM E90.
Maximum flame spread rating of 75 in accordance with ASTM E84.
- C. Paint surfaces exposed to view from Owner occupied areas.

1.7 PROTECTION OF INSTALLED WORK

- A. Protect installed Work and provide special protection where specified in individual specification sections.
- B. Provide temporary and removable protection for installed Products. Control activity in immediate work area to prevent damage.
- C. Provide protective coverings at walls, projections, jambs, sills and soffits of openings.
- D. Protect finished floors, stairs, and other surfaces from traffic, dirt, wear, damage, or movement of heavy objects, by protecting with durable sheet materials.
- E. Prohibit traffic or storage upon waterproofed or roofed surfaces. If traffic or activity is necessary, obtain recommendations for protection from waterproofing or roofing material manufacturer.
- F. Prohibit traffic from landscaped areas.

Section 01560

TEMPORARY CONTROLS

1.8 SECURITY

- A. Provide security and facilities to protect Work, and existing facilities, and Owner's operations from unauthorized entry, vandalism, or theft.
- B. Coordinate with Owner's security program.
- C. Building Access:
 - 1. If, in order to execute the work, it becomes necessary to issue keys to the Contractor, a deposit of \$200.00 will be required for each key so issued. Deposits will be returned to the Contractor upon the return of the keys to the University.
 - 2. In the event that a key is lost and is not returned to the University, thereby breaching the security of the building(s), the deposit shall be forfeited, and in addition, the Contractor shall be held liable for the cost of re-keying of the building(s) by the Owner.
 - 3. Where keyless access systems are in place, Contractor and subcontractors will be authorized to purchase Owner's "Cat cards" at a cost of \$15 each for building access in lieu of keys.

1.9 EROSION AND SEDIMENT CONTROL

- A. Plan and execute construction by methods to control surface drainage from cuts and fills, from borrow and waste disposal areas. Prevent erosion and sedimentation to comply with the University of Arizona Storm Water Management Plan dated March 10, 2003.
- B. Minimize amount of bare soil exposed at one time.
- C. Provide temporary measures such as berms, dikes, and drains, to prevent water flow.
- D. Construct fill and waste areas by selective placement to avoid erosive surface silts or clays.
- E. Periodically inspect earthwork to detect evidence of erosion and sedimentation; promptly apply corrective measures.

1.10 NOISE CONTROL

- A. Provide methods, means and facilities to minimize noise produced by construction operations.
- B. The Contractor shall comply with all local sound control and noise level rules, regulations and ordinances, which apply to any work performed pursuant to the contract including excavation, hauling and dumping.
- C. Haul trucks and equipment shall be maintained and operated in such a manner so as to minimize the generation of noise. The Owner reserves the right to review the

DIVISION 1

UA No.

Section 01560

TEMPORARY CONTROLS

operation of this equipment throughout the haul route to insure that no unnecessary noise is generated. The Contractor will be required to remedy any unsatisfactory conditions. In no case will the use of engine compression brakes be permitted.

D. Haul trucks shall not be hired on a piecework basis.

2 PART 2 PRODUCTS

Not Used

3 PART 3 EXECUTION

Not Used.

END OF SECTION

Section 01561

CONSTRUCTION CLEANING

1 PART 1 GENERAL

1.1 SECTION INCLUDES:

- A. General Requirements
- B. Cleaning Materials
- C. Waste Disposal
- D. Clean up

1.2 RELATED SECTIONS

- A. Section 01700 – Contract Closeout

1.3 GENERAL REQUIREMENTS

- A. General: Contractor and each Subcontractor and Installer is responsible for specific cleaning operations of his work.
- B. Safety and insurance standards: State Industrial Commission (of Arizona) OSHA.
- C. Fire Protection: Store volatile waste in covered metal containers, and remove from the premises daily.
- D. Pollution Control: Conduct clean-up and disposal operations to comply with applicable anti-pollution laws and local ordinances. Burning or burying of waste materials on the site is not permitted. Disposal of volatile fluids and wastes in storm or sanitary sewers, or into streams or waterways is not permitted.
- E. Dust Control: Provide a plan acceptable to the Owner for preventing generation of dust due to construction operations on site, along haul routes, in equipment parking areas, and in waste areas. This plan may consist of water sprinkling or an equivalent service in compliance with State and Pima County Control Rules and Regulations.
- F. Dust Control: The work under this section shall consist of applying all water required for the control of dust as considered necessary for the safety and convenience of the public, for the reduction of the dust nuisance to adjacent buildings and property, and for the allaying of dust on roads used to haul materials, all in accordance with the requirements of the Pima County Air Pollution Control District Ordinance. This project is located at the [] of the University campus adjacent to **[research], [teaching] and [residential facilities]** and dust control is a serious concern.
 - 1. Water utilized for dust control purposes shall be that quantity required to assure conformance with the Pima County Air Pollution Control Ordinance as administered by the Pima County Health Department.

Section 01561

CONSTRUCTION CLEANING

2. The Contractor shall also comply with the applicable requirements of Title 49 – Public Health and Safety, Chapter 3 Air Quality, of the Arizona Revised Statutes, and with the Arizona Administrative Code, Title 18 – Environmental Quality, Chapter 2 Air Pollution Control, Arizona Department of Environmental Quality pursuant to the authority granted by the Statutes.
 3. All loads are to be satisfactorily covered and secured prior to hauling off site.
- G. When dust-generating work is performed in the vicinity of active fire alarm devices, temporary fire alarm bypasses will be required.
- 2 PART 2 PRODUCTS
- 2.1 CLEANING MATERIALS
- A. Use only cleaning materials recommended by manufacturer of surface to be cleaned. Use cleaning materials only on surfaces recommended by cleaning material manufacturer.
- 3 PART 3 EXECUTION
- 3.1 WASTE DISPOSAL
- A. Collection and Disposal of Wastes:
1. Establish and enforce a daily system for collection and disposing of waste materials from construction areas and elsewhere at the project site. Provide suitable trash containers at a central collection point on the site. Provide chutes or other suitable means for removing trash safely and cleanly from elevated portions of the work.
 2. Comply with NFPA 241 for removal of combustible waste material and debris.
 3. Maintain project in accordance with State Industrial Commission (of Arizona) OSHA.
 4. Contractor and each Subcontractor and Installer is responsible for cleaning and removal of his trash and debris to this collection point.
 5. Do not hold collected materials at the site for periods of more than seven days. Handle hazardous, dangerous, or unsanitary wastes separately from other waste materials, by containerizing properly. Dispose of each category of waste material in a lawful manner. Do not bury or burn waste materials on the Owner's property.
 6. Enforce strict prohibition against the washing of waste materials down sewers or into waterways.

Section 01561

CONSTRUCTION CLEANING

7. Waste concrete and masonry shall be removed from the site and legally disposed of by masonry and concrete installers.

3.2 CLEAN UP

A. Cleaning and Protection of Work:

1. At the time each unit of work or element of the construction is completed.
2. Where subsequent construction activities could result in damage to other work in place, provide appropriate protective covering or other provisions.
3. Repeat cleaning and protection operations during remainder of construction period, wherever work might otherwise be damaged by sustained soiling or exposure.

B. During Construction:

1. Oversee cleaning and ensure that building, grounds, and public properties are maintained free from accumulation of waste materials and rubbish.
2. Take measures to prevent spread of trash, debris, cartons, packaging, or other waste materials on or off the Project Site by wind.
3. Sprinkle dusty debris with water.
4. At reasonable intervals during progress of work or as directed by the Owner, clean up site and access and dispose of waste materials, rubbish, and debris.
5. Remove snow and ice from public sidewalks adjacent to site and from access ways to the building and construction.
6. Clean adjacent and nearby streets of dirt occasioned by construction operations; frequency and methods as required by governing authority.
7. Vacuum clean interior building areas when ready to receive finish painting.

C. Contaminated Earth:

1. Remove earth contaminated by construction operations and dispose of off site. Replace with clean soils, as approved, in accordance with Section [02200] using materials appropriate to the location on the site and methods specified for fills and backfills.
2. Contaminated earth includes, but is not limited to, waste concrete and mortar; debris and waste materials, areas used for cleaning tools, washing mixers, and concrete trucks; and areas containing oils, solvents, paints, and similar liquids or other residues.

DIVISION 1

UA No.

Section 01561

CONSTRUCTION CLEANING

END OF SECTION

1 PART 1 GENERAL

1.1 SECTION INCLUDES

- A. Construction parking controls.
- B. Flag persons.
- C. Flares and lights.
- D. Haul routes.
- E. Traffic signs and signals.
- F. Removal.

1.2 RELATED SECTIONS

- A. Section 01010 – Summary of Work.
- B. Section 01039 – Coordination and Meetings.
- C. Section 01555 – Construction Facilities
- D. Section 01560 - Temporary Controls.

2 PART 2 PRODUCTS

2.1 SIGNS, SIGNALS, AND DEVICES

- A. Post Mounted and Wall Mounted Traffic Control and Informational Signs: Specified in Section 01580.
- B. Traffic cones and Drums, Flares and Lights: As approved by local jurisdictions.
- C. Flag-person Equipment: As required by local jurisdictions.

3 PART 3 EXECUTION

3.1 CONSTRUCTION PARKING CONTROL.

- A. Control vehicular parking to prevent interference with public traffic and parking, access by emergency vehicles, and Owner's operations.

Section 01570

TRAFFIC REGULATION

- B. Parking of Contractor's vehicles and vehicles of the Contractor's employees shall be only at locations designated by the Owner. The exact quantity and location for Contractor parking will be verified at the Pre-Construction Conference. The location will be as close to the construction site as possible. Vehicle spaces will be limited in number, and the vehicles must have permits properly displayed. The Contractor may apply to the parking Services Field Coordinator at 621-3756 for permits to park on campus. If granted, the costs for these permits will be borne by the Contractor. The permits are transferable and are valid for one year with the unused portion being refundable. Verify costs and all conditions with the Owner. Apply for permits sufficiently in advance.
- C. If a vehicle is permitted and parked in an unauthorized space, a citation will be issued. If vehicle does not display permit, a citation will be issued.
- D. Contractor can request additional permits at his expense if Owner's Parking and Transportation Department approves the request.

3.2 FLAG PERSONS

- A. Provide trained and equipped flag persons to regulate traffic when construction operations or traffic encroach on public traffic lanes.

3.3 FLARES AND LIGHTS

- A. Use flares and lights during hours of low visibility to delineate traffic lanes and to guide traffic.

3.4 HAUL ROUTES

- A. Consult with authority having jurisdiction, establish public thoroughfares to be used for haul routes and site access.

*****[OR]*****

- B. Drawings indicate haul routes designated by authorities for use of construction traffic.
- C. Confine construction traffic to designated haul routes.
- D. Provide traffic control at critical areas of haul routes to regulate traffic, to minimize interference with public traffic.

3.5 TRAFFIC SIGNS AND SIGNALS

- A. At approaches to site and on site, install at crossroads, detours, parking areas, and elsewhere as needed to direct construction and affected public traffic.
- B. Relocate as Work progresses, to maintain effective traffic control.

DIVISION 1

UA No.

Section 01570

TRAFFIC REGULATION

3.6 REMOVAL

- A. Removal equipment and devices when no longer required.
- B. Repair damage caused by installation.
- C. Remove post settings in their entirety.

END OF SECTION

Section 01580

PROJECT IDENTIFICATION AND SIGNS

1 PART 1 GENERAL

1.1 SECTION INCLUDES

- A. Project identification sign.
- B. Project informational signs.
- C. Maintenance.
- D. Removal.

1.2 RELATED SECTIONS

- A. Section 01010 – Summary of Work.
- B. Section 01555 – Construction Facilities
- C. Section 01560 - Temporary Controls.
- D. Section 01570 – Traffic Regulation.

1.3 QUALITY ASSURANCE

- A. Design sign and structure to withstand 60 miles/hr wind velocity.
- B. Sign Painter: Experienced as a professional sign painter for minimum three years.
- C. Finishes, Painting: Adequate to withstand weathering, fading, and chipping for duration of construction.

1.4 SUBMITTALS

- A. Section 01300 – Submittals: Shop drawings.
- B. Show content, layout, lettering, color, and sizes.

2 PART 2 PRODUCTS

2.1 SIGN MATERIALS

- A. Structure and Framing: New wood, structurally adequate, 4x4 minimum post size.
- B. Sign Surfaces: Exterior grade plywood with medium density overlay, minimum 3/4 inch thick, standard large sizes to minimize joints.
- C. Rough Hardware: Galvanized.

April 25, 2007

Section 01580

PROJECT IDENTIFICATION AND SIGNS

- D. Paint and Primers: Exterior quality, two coats; sign background of color as selected.
- E. Lettering: Exterior quality paint, as selected.

2.2 PROJECT IDENTIFICATION SIGN

- A. One painted sign of construction, design, and content shown on sample Project Sign Details at end of section.
- B. Actual Names for this Project Are:

Project Name:

Architect:

Construction Manger @ Risk:

Project Management:

- C. Content: As Indicated on Project Sign Details.
- D. Graphic Design, Colors, Style of Lettering: As Indicated on Project Sign Details.
- E. The University may elect to place a decal of a rendering or perspective view of the project in the upper left hand corner of the sign.
- F. Obtain information on required University of Arizona word marks from Owner. Only use the electronic file of the indicated wordmark provided by the Owner for incorporation into the project sign. The wordmark idicated in the Project Sign Detail is "UA Horizontal 200-281-no tag" and is the only wordmark approved for use on the Project Identification Sign.

2.3 PROJECT INFORMATIONAL SIGNS

- A. Painted informational signs of same colors and lettering as Project Identification sign, or standard products; size lettering to provide legibility at 100 foot distance.
- B. Provide directional signs at each field office, storage shed(s) and site entries as required to direct traffic into and within site. Relocate as Work progress requires.

2.4 OTHER SIGNS

- A. No other promotional signage for consultants, contractors, subcontractors, etc. will be allowed on the construction fence or as free standing signs anywhere on the site.

Section 01580

PROJECT IDENTIFICATION AND SIGNS

3 PART 3 EXECUTION

3.1 INSTALLATION

- A. Install free standing project identification sign within 15 days after start date specified in Notice to Proceed.
- B. Erect at designated location.
- C. Erect supports and framing on secure foundation, rigidly braced and framed to resist wind loadings.
- D. Install sign surface plumb and level, with butt joints. Anchor securely. Bottom edge of sign shall be a minimum of 4'-0" above adjacent grade.
- E. Paint exposed surfaces of sign, supports, and framing.

3.2 MAINTENANCE

- A. Maintain signs and supports clean, repair deterioration and damage.

3.3 REMOVAL

- A. Remove signs, framing, supports, and foundations at completion of Project and restore the area.

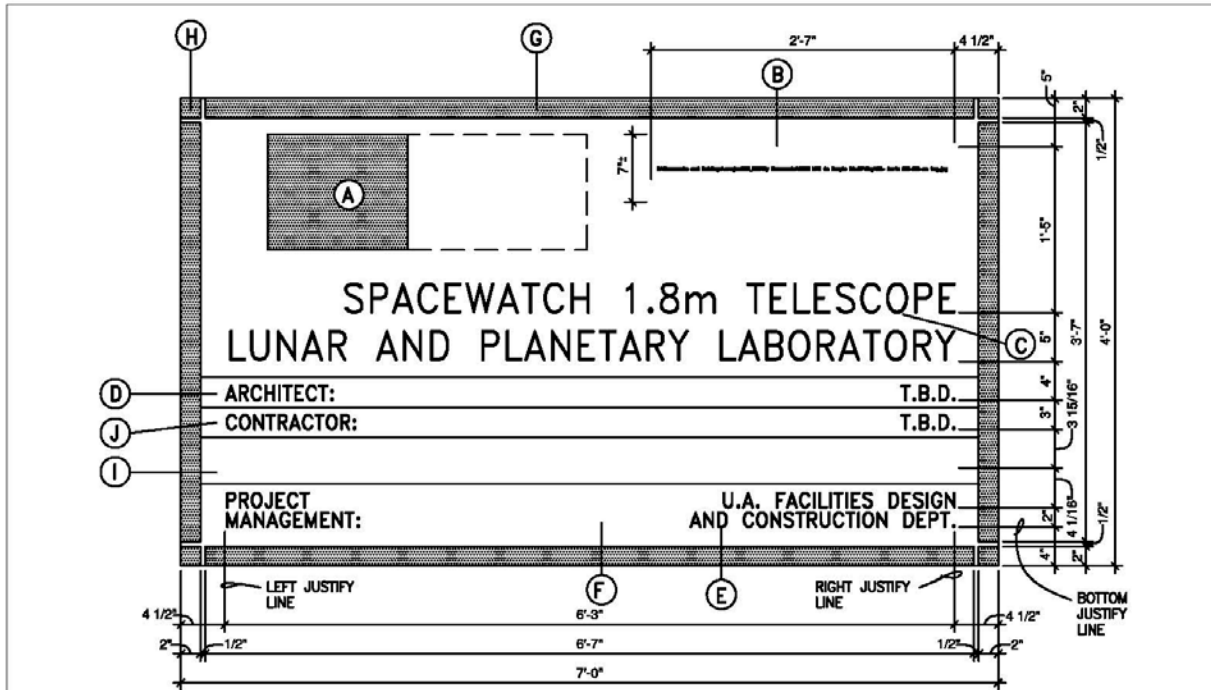

JOB SIGN ELEVATION

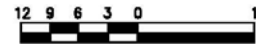

PAINTING AND LETTERING SCHEDULE				
MARK	LETTERING STYLE	SIZE	PAINTING COLOR	REMARKS
A	PROJECT GRAPHIC IMAGE	AS SHOWN	_____	PROJECT GRAPHIC-ELECTRONIC FILE PROVIDED BY FDC
B	UA WORDMARK HORZ. RED & BLUE	AS SHOWN	BRIGHT RED-PMS 200 BRILLIANT BLUE-PMS 281	PER UA TRADEMARK. .EPS FILE WILL BE PROVIDED
C	HELVETICA-MEDIUM	3"	BLACK	HOLD TO ONE LINE CAN BE TWO IF NECESSARY
D	HELVETICA-MEDIUM	1 1/2"	BLACK	FIRM IDENTIFICATION
E	HELVETICA-REGULAR	1 1/2"	BLACK	FIRM NAME
F	_____	_____	POLAR WHITE	BACKGROUND
G	_____	_____	BRILLIANT BLUE (CHROMATIC L156)	INTERMEDIATE BORDER
H	_____	_____	BRIGHT RED (CHROMATIC L104)	BORDER CORNER
I	_____	_____	_____	BLANK FOR DISCRETIONARY USE
J	_____	_____	_____	CONSTRUCTION MANAGER ● RISK FOR CM●R PROJECT DELIVERIES

NOTE:
CONSTRUCTED OF 3/4" EXT GRADE PLYWOOD, BOTTOM EDGE OF SIGN SHALL BE 4'-0" ABOVE ADJACENT GRADE MINIMUM, BRACING AND SUPPORT TO BE RESPONSIBILITY OF CONTRACTOR.

DIVISION 1

UA No.

Section 01580

PROJECT IDENTIFICATION AND SIGNS

END OF SECTION

Section 01590

FIELD OFFICES AND SHEDS

1 PART 1 GENERAL

1.1 SECTION INCLUDES

- A. Use of Existing Facilities
- B. Use of Permanent Facilities
- C. Materials, Equipment, Furnishings
- D. Construction
- E. Environmental Control
- F. Contractor Office and Facilities
- G. Storage Areas and Sheds
- H. Preparation
- I. Installation
- J. Maintenance and Cleaning
- K. Removal

1.2 RELATED SECTIONS

- A. Section 01010 – Summary of Work.
- B. Section 01555 – Construction Facilities
- C. Section 01560 - Temporary Controls.
- D. Section 01550 – Access Roads.
- E. Section 01580 – Project Identification and Signs.
- F. Section 01600 – Material and Equipment.

1.3 USE OF EXISTING FACILITIES

- A. Existing facilities shall not be used for field offices or for storage.

1.4 USE OF PERMANENT FACILITIES

- A. When permanent facilities are enclosed with operable utilities, relocate offices and storage into building, with written agreement of Owner, and remove temporary buildings.

Section 01590

FIELD OFFICES AND SHEDS

2 PART 2 PRODUCTS

2.1 MATERIALS, EQUIPMENT, FURNISHINGS

A. Materials, Equipment, Furnishings: Serviceable, new or used, adequate for required purpose.

2.2 CONSTRUCTION

A. Portable or mobile buildings, or buildings constructed with floors raised above ground, securely fixed to foundations, with steps and landings at entrance doors.

B. Construction: Structurally sound, secure, weather tight enclosures for office and storage spaces. Maintain during progress of Work; remove when no longer needed.

C. Temperature Transmission Resistance of Floors, Walls, and Ceilings; Compatible with occupancy and storage requirements.

D. Exterior Materials: Weather resistant, finished color acceptable to Owner.

E. Interior Materials in Offices: Sheet type materials for walls and ceilings, pre-finished or painted; resilient floors and bases.

G. Lighting for Offices: 50 ft-C at desk top height, exterior lighting at entrance doors.

H. Fire Extinguishers: Appropriate type fire extinguisher at each office and each storage area.

I. Interior Materials in Storage Sheds: As required to provide specified conditions for storage of products.

2.3 ENVIRONMENTAL CONTROL

A. Heating, Cooling, and Ventilating for Offices: Automatic equipment to maintain comfortable conditions.

B. Storage Spaces: Heating and ventilation as needed to maintain Products in accordance with Contract Documents; adequate lighting for maintenance and inspection of Products.

2.4 CONTRACTOR OFFICE AND FACILITIES

A. Size: For Contractor's needs and to provide space for project meetings.

B. Telephone/Data: As specified in Section 01510.

C. Fax: As specified in Section 01510.

Section 01590

FIELD OFFICES AND SHEDS

- D. Furnishings in Meeting Area: Conference table and chairs to seat at least eight persons; racks and files for Contract Documents, submittals, and project record documents.
- E. Furnishings for Owner and Architect/Engineer: Separate plan table and chair for sole use of Owner and Architect/Engineer.
- F. Other Furnishings: Contractor's option.
- G. Equipment: Six adjustable band protective helmets for visitors, one 10 inch outdoor weather thermometer.

2.5 STORAGE AREAS AND SHEDS

- A. Size to storage requirements for products of individual Sections, allowing for access and orderly provision for maintenance and for inspection of products to requirements of Section 01600.

3 PART 3 EXECUTION

3.1 PREPARATION

- A. Fill and grade sites for temporary structures to provide drainage away from buildings.

3.2 INSTALLATION

- A. Install office spaces ready for occupancy 15 days after date fixed in the Notice to Proceed.
- B. Employee Residential Occupancy: Not allowed on Owner's property.

3.3 MAINTENANCE AND CLEANING

- A. Weekly janitorial services for offices; periodic cleaning and maintenance for office and storage areas.
- B. Maintain approach walks free of debris, mud, water, and snow.

3.4 REMOVAL

- A. At completion of Work remove buildings, foundations, utility services, and debris. Restore areas.

END OF SECTION

Section 01600

MATERIAL AND EQUIPMENT

1 PART 1 GENERAL

1.1 SECTION INCLUDES

- A. Products.
- B. Transportation and handling.
- C. Storage and protection.
- D. "Or Equal" Products.
- E. Substitutions.

1.2 RELATED SECTIONS

- A. Document 00100 – Instructions to **[CM @ Risk]** **[Bidders]**: Product options and substitution procedures.
- B. Section 01027 – Applications for Payment.
- C. Section 01400 – Quality Control.

1.3 PRODUCTS

- A. Do not use materials and equipment removed from existing premises, except as specifically permitted by the Contract Documents.
- B. Provide interchangeable components of the same manufacture for components being replaced.
- C. Only unmanufactured materials produced in the United States of America and only products manufactured in the United States of America, chiefly from materials produced in the United States of America, shall be used under this Contract in construction of the project, unless prior approval is obtained from the Owner.**TRANSPORTATION AND HANDLING**

- A. Transport and handle Products in accordance with manufacturer's instructions.
- B. Deliver all manufactured materials in the original packages, containers, or bundles with seals unbroken bearing the name or identification mark of the manufacturer.
- C. Deliver fabrications in as large assemblies as practicable and where specified to be shop-primed or shop finished, they shall be packaged or crated as required to preserve such priming or finish intact and free from abrasion.
- D. Promptly inspect shipments to ensure that Products comply with requirements, quantities are correct, and Products are undamaged.

Section 01600

MATERIAL AND EQUIPMENT

- E. Provide equipment and personnel to handle Products by methods to prevent soiling, disfigurement, or damage.

1.5 STORAGE AND PROTECTION

- A. Store and protect Products in accordance with manufacturers' instructions.
- B. Store with seals and labels intact and legible.
- C. Store sensitive Products in weather tight, climate controlled, enclosures in an environment favorable to Product.
- D. Store all materials in such manner as necessary to properly protect same from damage. Materials or equipment damaged by handling, weather, dirt, or from any other cause will not be acceptable.
- E. Store material so as to cause no obstructions, stored off sidewalks, roadways, and underground services. The Contractor shall be responsible for protecting all material and equipment furnished under the Contract.
- F. When any room in the project is used as a shop or store room, the Contractor shall be responsible for any repairs, patching or cleaning necessary due to such use. Location of such storage space shall be subject to approval of the Architect **[Construction Manager] [Owner]**.
- G. For exterior storage of fabricated Products, place on sloped supports above ground.
- H. Provide suitable off-site storage and protection when site does not permit on-site storage or protection.
- I. Cover Products subject to deterioration with impervious sheet covering. Provide ventilation to prevent condensation and degradation of Products.
- J. Store loose granular materials on solid flat surfaces in a well-drained area. Prevent mixing with foreign matter.
- K. Provide equipment and personnel to store Products by methods to prevent soiling, disfigurement, or damage.
- L. Arrange storage of Products to permit access for inspection. Periodically inspect to verify Products are undamaged and are maintained in acceptable condition.

1.6 "OR EQUAL" PRODUCTS

- A. During the **[Guaranteed Maximum Price (GMP)] [Bid]** period, requests for approval of "or equal" products shall follow the process specified in the **[Instructions to CM@R.] [Instruction to Bidders.]**

Section 01600

MATERIAL AND EQUIPMENT

1.7 SUBSTITUTION

- A. Instructions to **[CM@R] [Bidders]** specify procedures for submitting requests for prior approval of equal products during the **[GMP] [Bid]** period.
- B. Award of the contract in accordance with Contract Documents requires that the specified manufacturers, trade names or materials and equipment shall be furnished and installed.
- C. Substitutions will not be allowed unless specifically submitted and approved in accordance with the following provisions.
- D. Owner will not approve a substitution of materials or equipment on the basis of lower price after **[GMP is accepted] [bids are opened]**. The conditions under which a request for substitution will be considered are:
 - 1. The request for substitution is a result of changes in scope, materials or equipment made by Owner during post-bid cost reduction negotiations as allowed by Subsection 3-803.B.7 of the University Procurement Code.
 - 2. Owner actions, such as selection of Optional Price(s) or optional work, makes a suppliers bid non-responsive or significantly non-competitive.
 - 3. Written admission by the manufacturer of its inability to furnish the product required by the Contract Documents in a timely manner.
 - 4. A written refusal by the supplier to furnish the product for the price included in its bid on bid day.
 - 5. The manufacturer becomes insolvent or bankrupt, ceases its business operations, or otherwise becomes unable to furnish the specified product.
 - 6. Persistent or repeated failure or refusal by the manufacturer to furnish its product as reasonably expected by the General Contractor to enable the General Contractor to meet its contractual commitment to the University.
- E. A request constitutes a representation that the Contractor:
 - 1. Has investigated proposed Product and determined that it meets or exceeds the quality level of the specified Product.
 - 2. Will provide the same warranty for the Substitution as for the specified Product.
 - 3. Will coordinate installation and make changes to other Work which may be required for the Work to be complete with no additional cost to Owner.
 - 4. Waives claims for additional costs or time extensions which may subsequently become apparent.

Section 01600

MATERIAL AND EQUIPMENT

5. Will reimburse Owner and/or Architect/Engineer for review or redesign services associated with re-approval by authorities.
- F. Substitution shall not be offered unless a thorough check is made of all related items and interferences, all approved or pending changes in the Work, and any changes in the order of performance of the Work or the construction progress schedule that are or may be necessary to accommodate the proposed substitution. Prepare drawings of revised equipment and piping arrangements caused by substitutions.

Such drawings shall be at least equal in quality and detail to Contract Drawings. The cost of supplying drawings shall be included by the Contractor in his estimate of proposed substituted materials.
- G. By offering a substitution Contractor shall accept responsibility for its effect on the work of all trades, including any possible delays in completion time of Project. All costs of changes in the work of other trades and As-Built Drawings, etc., affected by inclusion of Contractor requested substitutions shall be paid by the Contractor.
- H. Substitutions will not be considered when they are indicated or implied on shop drawing or product data submittals, with separate written request, or when acceptance will require revision to the Contract Documents.
- I. Substitution Submittal Procedure:
 1. Requests for approval of substitute manufacturer, trade name or materials shall be submitted on the Substitution Request Form, Section 01601. Submit three [] copies of request for Substitution for consideration. Limit each request to one proposed Substitution.
 2. Submit shop drawings, product data, and certified test results attesting to the proposed Product equivalence. Burden of proof is on proposer. Submittals shall contain sufficient information, samples or other data as necessary to provide direction comparison to the specified products. Each submittal shall be well marked and identified as to the type and kind of items being submitted for approval. Lack of proper information will be sufficient cause for rejection. References to catalogs that the Architect may or may not have will not be accepted.
 3. The Architect/Engineer will notify Contractor in writing of decision to accept or reject request.
- J. Unless specifically submitted and approved in accordance with the above, substitutions will not be allowed.

2 PART 2 PRODUCTS

DIVISION 1

UA No.

Section 01600

MATERIAL AND EQUIPMENT

3 PART 3 EXECUTION

Not Used.

END OF SECTION

DIVISION 1

UA NO.

SECTION 01601

SUBSTITUTION REQUEST FORM

SUBSTITUTION REQUEST FORM

UA Project Name:

UA Project No.:

We hereby submit for your consideration the following material/product in lieu of the specified item for the above referenced product.

Section No.:

Page:

Paragraph / Line:

Item:

Proposed Substitution:

Attach complete product descriptions, drawings, specifications, and any other information or data to fully describe the proposed item.

A. The proposed item meets or exceeds specification requirements?

Yes:

No:

B. Will any changes be required to building design in order to properly install the proposed item?

Yes:

No:

If yes, please explain:

C. Supplier is responsible for all changes to the building design, including engineering and drawings costs, caused by requested approval/substitution?

Yes:

No:

Issued January 26, 2004

DIVISION 1

UA NO.

SECTION 01601

SUBSTITUTION REQUEST FORM

UA Project Name:

UA Project No.:

D. List all differences between proposed substitution and specified item.

SPECIFIED ITEM

PROPOSED ITEM

E. Does substitution affect drawing dimensions?

Yes: No:

If yes, please explain:

F. What affect does the substitution have on other trades?

G. Proposed product is subject to all requirements of specifications, including warranties?

Yes: No:

H. Will proposed substitution affect progress schedule?

Yes: No:

If yes, please explain:

I. Will maintenance and service parts be locally available for proposed substitution?

Yes: No:

J. Will proposed substitution require more license fees or royalties than specified product?

Yes: No:

K. Will proposed product meet all requirements of reviewing agencies (health, life, safety, fire, etc.)?

Yes: No:

If no, please explain:

Issued January 26, 2004

DIVISION 1

UA NO.

SECTION 01601

SUBSTITUTION REQUEST FORM

UA Project Name:

UA Project No.:

Please quantify or explain benefits to Owner:

Submitted By:

Representative:

Company:

Address:

Phone:

Representative's Signature:

Date:

For Architect's Use Only:

Accepted:

Accepted As Noted:

Rejected:

Received Too Late:

By:

Date:

Remarks:

END OF SECTION

Issued January 26, 2004

01601-3

Section 01650

STARTING OF SYSTEMS

1 PART 1 GENERAL

1.1 SECTION INCLUDES

- A. Starting systems.
- B. Demonstration and instructions.
- C. Testing, adjusting, and balancing.
- D. Commissioning.

1.2 RELATED SECTIONS

- A. Section 01400 – Quality Control.
- B. Section 01700 – Contract Closeout.

1.3 STARTING SYSTEMS

- A. Coordinate schedule for start-up of various equipment and systems.
- B. Notify Architect/Engineer and Owner seven days to prior to start-up of each item.
- C. Verify that each piece of equipment or system has been checked for proper lubrication, drive rotation, belt tension, control sequence, and for conditions which may cause damage.
- D. Verify tests, meter readings, and specified electrical characteristics agree with those required by the equipment or system manufacturer.
- E. Verify that wiring and support components for equipment are complete and tested.
- F. Execute start-up under supervision of applicable manufacturer's representative or Contractors' personnel in accordance with manufacturers' instructions.
- G. When specified in individual specification Sections, require manufacturer to provide authorized representative to be present at site to inspect, check, and approve equipment or system installation prior to start-up, and to supervise placing equipment or system in operation.
- H. Submit a written report in accordance with Section 01300 that equipment or system has been properly installed and is functioning correctly.

1.4 DEMONSTRATION AND INSTRUCTIONS

- A. Demonstrate operation and maintenance of Products to Owner's personnel two weeks prior to date of final inspection.

Section 01650

STARTING OF SYSTEMS

- B. Demonstrate Project equipment instructed by a qualified manufacturers' representative who is knowledgeable about the Project.
- C. For equipment or systems requiring seasonal operation, perform demonstration for other season within six months.
- D. Utilize operation and maintenance manuals as basis for instruction. Review contents of manual with Owners' personnel in detail to explain all aspects of operation and maintenance.
- E. Demonstrate start-up, operation, control, adjustment, trouble-shooting, servicing, maintenance, and shutdown of each of equipment at scheduled time at designated location.
- F. Prepare and insert additional data in operations and maintenance manuals when need for additional data becomes apparent during instruction.
- G. The amount of time required for instruction on each item of equipment and system is that specified in individual sections.

1.5 TESTING, ADJUSTING, AND BALANCING

- A. Owner will appoint, employ, and pay for services of an independent firm to perform testing, adjusting, and balancing.
- B. The independent firm shall perform services specified in Section 15990.
- C. Reports shall be submitted by the independent firm to the Architect/Engineer indicating observations and results of tests and indicating compliance or non-compliance with the requirements of the Contract Documents.

1.6 COMMISSIONING

- A. Commissioning is primarily the responsibility of the Owner's Independent Commissioning Agent, with support for start-up, testing, and commissioning the responsibility of the Contractor. The commissioning process does not relieve the Contractor from participation in the process or diminish the role and obligations to complete all portions of work in a satisfactory and fully operational manner.
- B. Refer to appropriate sections in Divisions 15 and 16 for scope of work.

2 PART 2 PRODUCTS

Not Used.

3 PART 3 EXECUTION

Not Used.

DIVISION 1

UA No.

Section 01650

STARTING OF SYSTEMS

END OF SECTION

1 PART 1 GENERAL

1.1 SECTION INCLUDES

- A. Substantial Completion.
- B. Final Acceptance.
- C. Final Cleaning.
- D. Adjusting.
- E. Project Record Documents.
- F. Operation and Maintenance Data.
- G. Spare Parts and Maintenance Products.
- H. Warranties
- I. Maintenance Service.

1.2 RELATED SECTIONS

- A. Section 01500 – Construction Facilities and Temporary Controls.
- B. Section 01555 – Construction Facilities.
- C. Section 01560 – Temporary Controls.
- D. Section 01650 – Starting of Systems.
- E. Section [_____ - **Project Commissioning.**]
- F. Section 01730 – Operation and Maintenance Data.
- G. Section 01740 – Warranties.

1.3 SUBSTANTIAL COMPLETION (See General Conditions)

- A. GENERAL: The following conditions must exist for the Work **for any designated portion thereof** to be considered as substantially complete in accordance with Section 31 of the General Conditions:

- 1. All Life Safety systems are operating and are approved by the authorities having jurisdiction.

Section 01700

CONTRACT CLOSEOUT

2. All building systems (mechanical, plumbing, electrical and other special systems) are operating as specified except for minor adjustments such as final balancing of flows, final programming of controls, etc.
 3. All of the Contractor's remaining work may be performed without major interruption or disruption of the Owner's operations, should Owner occupy the facility.
 4. All test and balance work on the building systems has been found by the Architect to be substantially complete, based upon review of submitted reports.
 5. All preliminary operating and maintenance information required by Section **[01700] [01730]** of the Specifications has been submitted and approved.
 6. See the General Conditions for the definition of the term "Substantial Completion".
- B. Preliminary Procedures:
1. Contractor shall give notice to Owner **[and Construction Manager]** of the claim of Substantial Completion of the Project or portion thereof in accordance with the General Conditions.
 2. In the Application for Payment that coincides with, or first allows, the date Substantial Completion is claimed, show 100% completion for the portion of the Work claimed as substantially complete. Include supporting documentation for completion as indicated in the Contract Documents. If 100% completion cannot be shown, include list of incomplete items, the value of incomplete construction, and reasons for the Work being incomplete. This list of remaining incomplete work termed an "Initial Punch List" should be prepared in close cooperation and agreement with the **[Architect] [Construction Manager]**.
 3. Advise Owner, Architect, **[and Construction Manager]** of pending insurance changeover requirements.
 4. Submit specific warranties, final certifications, and similar documents.
 5. Obtain and submit releases enabling Owner unrestricted use of the Work and access to services and utilities, including occupancy permits, operating certificates, and similar releases.
 6. Submit test and balance reports, preliminary operating and maintenance information.
 7. Deliver tools, spare parts, extra stocks of materials, and similar physical items to Owner.
 8. Make final change-over of permanent locks, transmit keys to Owner, and advise Owner's personnel of change-over in security provisions.

Section 01700

CONTRACT CLOSEOUT

9. Complete start-up and testing of systems and instructions for Owner's operating/maintenance personnel. Discontinue or change over and remove from project site temporary facilities and services, along with construction tools and facilities, mock-ups, and similar elements.
10. Complete final cleaning requirements.
11. Touch-up and otherwise repair and restore marred exposed finishes.

C. Inspection and Certification Procedure:

1. In order to verify Substantial Completion, the **[Construction Manager]** Architect and his Engineers, as appropriate, within **[10] []** days of written receipt of request for inspection, will inspect the Project, provided specified prerequisites listed above are met. If they find it substantially complete, Owner will prepare the Certificate of Substantial Completion, AIA Document G704, and advise the Contractor by means of a "Punch List" inspection report prepared by the Architect of items required for completion and acceptance.

If Work is not substantially complete, Contractor will be advised of general reasons for this judgment or specific areas of non-compliance with the Contract Documents requiring correction or completion for the Work to be considered substantially complete.

- a. The "Substantial Completion" inspection will not be made until test and balance reports, and preliminary operating and maintenance information have been delivered to the Architect and found by him to be substantially complete.
 - b. The combined total number of "Punch List" items identified by the Contractor, **[Construction Manager]** Architect, and Owner shall not be excessive in number and scope. If the volume or nature of the deficiencies identified are deemed to be excessive, the inspection will be canceled and the Contractor shall assume responsibility for payment of the costs for additional inspections. The costs for such additional inspections will be deducted from any funds due the Contractor.
2. Proceed immediately to complete all items and transmit to the **[Construction Manager and]** Architect a weekly report of the progress on or completion of each item on the "Punch List" **[and the Contractor's list.]** Any non-conforming or incomplete work brought to the Architect's attention during this period will be added to the list.
 3. Should the Architect **[and Construction Manager]** determine that the work is not substantially complete, they will notify the Contractor, in writing, stating reasons. After the Contractor completes work, he shall resubmit certification and request for final inspection.

1.4 FINAL ACCEPTANCE

Section 01700**CONTRACT CLOSEOUT****A. Preliminary Procedures:**

1. Before requesting final inspection for certification of final acceptance and final payment, complete the following. List known exceptions in the request.
2. Submit any special warranties.
3. Submit Project Record Documents.
4. Submit final payment request with final releases and supporting documentation not previously submitted and accepted.
5. Submit certified copy of Architect's final Punch List of itemized work to be completed or corrected, stating that each item has been completed or otherwise resolved for acceptance, endorsed and dated by Architect.
6. Submit Contractor's Subcontracting Report to Owner's Small Business Program Coordinator.
7. Submit consent of surety to final payment, AIA G707, and Contractor's Affidavit of Payment of Debts and Claims, AIA G706.
8. Submit evidence of final, continuing insurance coverage complying with insurance requirements.
9. Remove all temporary facilities, services, surplus materials, rubbish, and similar materials.
10. When applicable, submit final meter readings for utilities and similar data as of the date of Substantial Completion or when Owner took possession of and responsibility for corresponding elements of the work.
11. Submit certification letter and backup testing information certifying that facility is mold free at the time of final acceptance.

B. Final Inspection:

1. Contractor shall submit written certification that:
 - a. Contract Documents have been reviewed.
 - b. Project has been inspected for compliance with Contract Documents.
 - c. Work has been completed in accordance with Contract Documents.
 - d. Equipment and systems have been tested in the presence of Owner's Representative and are operational.
2. The Architect will re-inspect the Work upon receipt of notice that the Work, including inspection list times from earlier inspections, has been completed,

Section 01700

CONTRACT CLOSEOUT

except items whose completion has been delayed because of circumstances acceptable to the **[Construction Manager and]** Architect. If additional inspections are required, the costs of such additional inspections will be deducted from any funds due the Contractor.

3. Upon completion of this inspection, the Architect will prepare a Certificate of Final Acceptance, or advise the Contractor of Work that is incomplete or of obligations that have not been fulfilled but are required for final acceptance.'
4. If necessary, inspection will be repeated. The Contractor shall assume responsibility for payment of the costs for additional inspections. These costs will be deducted from any funds due the Contractor.

1.5 FINAL CLEANING

- A. Execute final cleaning prior to final project assessment.
- B. Clean interior and exterior glass, surface exposed to view; remove temporary labels, stains and foreign substances, polish transparent and glossy surfaces, **[vacuum carpeted and soft surfaces.]**
- C. Clean equipment and fixtures to a sanitary condition with cleaning materials appropriate to the surface and materials being cleaned.
- D. **[Clean] [Replace]** filters of operating equipment.
- E. Clean debris from roofs, gutters, downspouts, and drainage systems.
- F. Clean site; sweep paved areas, rake clean landscaped surfaces.
- G. Remove waste and surplus materials, rubbish, and construction facilities from the site.

1.6 ADJUSTING

- A. Adjust operating Products and equipment to ensure smooth and unhindered operation.

1.7 PROJECT RECORD DOCUMENTS

- A. Maintain on site one set of the following record documents; record actual revisions to the Work:
 1. As-Built Drawings.
 2. Specifications.
 3. Addenda.

Section 01700

CONTRACT CLOSEOUT

4. Change Orders and other modifications to the Contract.
 5. Reviewed Shop Drawings, Product Data, and Samples.
 6. Manufacturer's instruction for assembly, installation, and adjusting.
- B. Ensure entries are complete and accurate, enabling future reference by Owner.
- C. Store record documents separate from documents used for construction.
- D. Record information concurrent with construction progress.
- E. Specifications: Legibly mark and record at each Product section description of actual Products installed, including the following:
1. Manufacturer's name and product model and number.
 2. Product substitutions or alternates utilized.
 3. Changes made by Addenda and modifications.
- F. As-Built Drawings **[and Shop Drawings]**: Legibly mark each item to record actual construction including:
1. Measured depths of foundations in relation to finish first floor datum.
 2. Measured horizontal and vertical locations of underground utilities and appurtenances, referenced to permanent surface improvements.
 3. Measured locations of internal utilities and appurtenances concealed in construction, referenced to visible and accessible features of the Work.
 4. Field changes of dimension and detail.
 5. Details not on original Contract drawings.
- G. Submit documents to Architect/Engineer **[Construction Manager] [Owner] [with claim for final Application for Payment.] [_____].]**

1.8 OPERATION AND MAINTENANCE DATA

- A. Submit data bound in 8-1/2 x 11 inch (A4) text pages, binders with durable covers.
- B. Prepare binder cover with printed title "OPERATION AND MAINTENANCE INSTRUCTIONS", title of project, and subject matter of binder when multiple binders are required.

Section 01700

CONTRACT CLOSEOUT

- C. Internally subdivide the binder contents with permanent page dividers, logically organized as described below; with tab titling clearly printed under reinforced laminated plastic tabs.
- D. Contents: Prepare a Table of Contents for each volume, with each Product or system description identified, typed on white bond paper, in three parts as follows:
1. Part 1: Directory, listing names, addresses, and telephone numbers of Architect/Engineer, **[Construction Manager]**, Contractor, Subcontractors, and major equipment suppliers.
 2. Part 2: Operation and maintenance instructions arranged by system and subdivided by specification section. For each category, identify names, addresses, and telephone numbers of Subcontractors and suppliers. Identify the following:
 - a. Significant design criteria.
 - b. List of equipment.
 - c. Parts list for each component.
 - d. Operating instructions.
 - e. Maintenance instructions for equipment and systems.
 - f. Maintenance instructions for **[special]** finishes, including recommended cleaning methods and materials, and special precautions identifying detrimental agents.
 3. Part 3: Project documents and certificates, including the following:
 - a. Shop drawings and product data.
 - b. Air and water balance reports.
 - c. Certificates.
 - d. Originals of warranties and bonds.
- E. Submit 1 draft copy of completed volumes **[15] []** days prior to final inspection. This copy will be reviewed and returned after final inspection, with Architect/Engineer **[and Construction Manager]** comments. Revise content of all documents sets as required prior to final submission.
- F. Submit three sets of revised final volumes, within 10 days after receipt of final comments.

Section 01700

CONTRACT CLOSEOUT

1.9 SPARE PARTS AND MAINTENANCE PRODUCTS

- A. Provide spare parts, maintenance, and extra Products in quantities specified in individual specification sections.
- B. Deliver to location designated by Owner; obtain receipt prior to final payment.

1.10 WARRANTIES

- A. The Contractor shall provide the Owner all product Warranties.
- B. The Contractor shall deliver to the Architect upon completion of all work under the Contract, his written warranty made out to the Owner on the Contractor's Letterhead, in the form included as specification Section 01741. This warranty shall be made to cover the minimum period specified in **[Section 24] [Article 2.7]** of the General Conditions of the Construction Agreement.
- C. Warranties from Contractor shall be supported by individual warranties from each trade or subcontractor and manufacturer or supplier covering work. Where specific sections of the specifications call for longer warranties, those specification sections shall be referenced in the second paragraph of the warranty.
- D. Provide notarized copies.
- E. Execute and assemble transferable warranty documents from Subcontractors, suppliers, and manufacturers.
- F. Provide Table of Contents and assemble in binder with durable cover.
- G. Submit prior to final Application for Payment.
- H. For items of Work delayed beyond date of Substantial Completion, provide updated submittal within **[10] [____]** days after acceptance, listing date of acceptance as start of warranty period.

1.11 MAINTENANCE SERVICE

- A. Furnish service and maintenance of components where indicated in specification sections for **[____] year from date of Substantial Completion.] [during the warranty period.] [_____].]**
- B. Examine system components at a frequency consistent with reliable operation. Clean, adjust, and lubricate as required.
- C. Include systematic examination, adjustment, and lubrication of components. Repair or replace parts whenever required. Use parts produced by the manufacturer of the original component.

DIVISION 1

UA No.

Section 01700

CONTRACT CLOSEOUT

D. Maintenance service shall not be assigned or transferred to any agent or Subcontractor without prior written consent of the Owner.

2 PART 2 PRODUCTS

Not Used.

3 PART 3 EXECUTION

Not Used.

END OF SECTION

Section 01730

OPERATION AND MAINTENANCE DATA

1 PART 1 GENERAL

1.1 SECTION INCLUDES

- A. Format and content of manuals.
- B. Instruction of Owner's personnel.
- C. Submittals.

1.2 RELATED SECTIONS

- A. Section 01300 – Submittals.
- B. Section 01400 – Quality Control: Manufacturer's instructions.
- C. Section 01600 – Material and Equipment.
- D. Section 01700 – Contract Closeout.
- E. Section 01740 – Warranties.
- F. Individual Specifications Sections: Specific requirements for operation and maintenance data.

1.3 QUALITY ASSURANCE

- A. Prepare instructions and data by personnel experienced in maintenance and operation of described products.

1.4 FORMAT

- A. Prepare data in the form of an instructional manual.
- B. Binders: Commercial quality, 8 ½ x 11 ring binders with durable covers. When multiple binders are used, correlate data into related consistent groupings.
- C. Cover: Identify each binder with typed or printed title OPERATION AND MAINTENANCE INSTRUCTIONS; identify title of Project; identify subject matter of contents.
- D. Provide tabbed dividers for each separate product and system, with typed description of product and major component parts of equipment.
- E. Text: Manufacturer' printed data, or typewritten data on bond paper.

Section 01730

OPERATION AND MAINTENANCE DATA

- F. Drawings: Provide with reinforced punched binder tab. Bind in with text; fold larger drawings to size of text pages.
- G. Contents: Prepare a Table of Contents for each volume, with each Product or system description identified, in three parts as follows:
1. Part 1: Directory, listing names, addresses, and telephone numbers of Architect/Engineer, **[Construction Manager]**, Contractor, Subcontractors, and major equipment suppliers.
 2. Part 2: Operation and maintenance instructions, arranged by system and subdivided by **[specification section]** [_____]. For each category, identify names, addresses, and telephone numbers of Subcontractors and suppliers. Identify the following”
 - a. Significant design criteria.
 - b. List of equipment.
 - c. Parts list for each component.
 - d. Operating instructions.
 - e. Maintenance instructions for equipment and systems.
 - f. Maintenance instructions for **[special]** finishes, including recommended cleaning methods and materials, and special precautions identifying detrimental agents.
 3. Part 3: Project documents and certificates, including the following:
 - a. Shop drawings and product data.
 - b. Air and water balance reports.
 - c. Certificates.
 - d. Photocopies of original warranties.

1.5 CONTENTS, EACH VOLUME

- A. Table of Contents: Provide title of Project; names, address, and telephone numbers of Architect/Engineer, **[Construction Manager]** Subconsultants, and Contractor with name of responsible parties; schedule of products and systems, indexed to content of the volume.
- B. For Each Product or System: List names, addresses and telephone numbers of Subcontractors and suppliers, including local source of supplies and replacement parts.
- C. Product Data: Mark each sheet to clearly identify specific products and component parts, and data applicable to installation. Delete inapplicable information.
- D. Drawings: Supplement product data to illustrate relations of component parts of equipment and systems, to show control and flow diagrams. **[Do not use Project Record Documents as maintenance documents.]**

Section 01730

OPERATION AND MAINTENANCE DATA

- E. Typed Text: As required to supplement product data. Provide logical sequence of instructions for each procedure, incorporating manufacturer's instructions as specified.
- F. Warranties: Originals as specified in Section 01740.

1.6 MANUAL FOR MATERIALS AND FINISHES

- A. Building Products, Applied Materials, and Finishes: Include product data, with catalog number, size, composition, and color and texture designations. Provide information for re-ordering custom manufactured Products.
- B. Instructions for Care and Maintenance: Include manufacturer's recommendations for cleaning agents and methods, precautions against detrimental agents and methods, and recommended schedule for cleaning and maintenance.
- C. Moisture Protection and Weather Exposed Products: Include product data listing applicable reference standards, chemical composition, and details of installation. Provide recommendations for inspections, maintenance, and repair.
- D. Additional Requirements: As specified in individual Product specification sections.
- E. Provide a listing of Table of Contents for design data, with tabbed fly sheet and space for insertion of data.

1.7 MANUAL FOR EQUIPMENT AND SYSTEMS

- A. Each Item of Equipment and Each System: Include description of unit or system, and component parts. Identify function, normal operating characteristics, and limiting conditions. Include performance curves, with engineering data and tests, and complete nomenclature and model number of replaceable parts.
- B. Panelboard Circuit Directories: Provide electrical service characteristics, controls, and communications.
- C. Include color coded wiring diagrams as installed.
- D. Operating Procedures: Include start-up, break-in, and routine normal operating instructions and sequences. Include regulation, control, stopping, shut-down, and emergency instructions. Include summer, winter, and any special operating instructions.
- E. Maintenance Requirements: Include routine procedures and guide for preventative maintenance and trouble shooting; disassembly, repair, and re-assembly. Instructions; and alignment, adjusting, balancing, and checking instructions.
- F. Provide servicing and lubrication schedule, and list of lubricants required.
- G. Include manufacturer's printed operation and maintenance instructions.

Section 01730

OPERATION AND MAINTENANCE DATA

- H. Include sequence of operation by controls manufacturer.
- I. Provide original manufacturer's parts list, illustrations, assembly drawings, and diagrams required for maintenance.
- J. Provide control diagrams by controls manufacturer as installed.
- K. Provide Contractor's coordination drawings, with color coded piping diagrams as installed.
- L. Provide charts of valve tag numbers, with location and function of each valve, keyed to flow and control diagrams.
- M. Provide list of original manufacturer's spare parts, current prices, and recommended quantities to be maintained in storage.
- N. Include test and balancing reports.
- O. Additional Requirements: As specified in individual Product specification sections.
- P. Provide a listing in Table of Contents for design data, with tabbed dividers and space for insertion of data.

1.8 INSTRUCTIONS OF OWNER PERSONNEL

- A. Before final inspection, instruct Owner's designated personnel in operation, adjustment, and maintenance of products, equipment, and systems, at agreed upon times.
- B. For equipment requiring seasonal operation, perform instructions for other seasons within **[six]** [_____] months.
- C. Use operation and maintenance manuals as basis for instruction. Review contents of manual with personnel in detail to explain all aspects of operation and maintenance.
- D. Prepare and insert additional data in Operation and Maintenance Manual when need for such data becomes apparent during instruction.

1.9 SUBMITTALS

- A. Submit two copies of preliminary draft or proposed formats and outlines of contents before start of Work. Architect/Engineer will review draft and return one copy with comments.
- B. For equipment, or component parts of equipment put into service during construction and operated by Owner, submit documents within ten days after acceptance.

Section 01730

OPERATION AND MAINTENANCE DATA

- C. Submit 1 copy of completed volumes **15** days prior to final inspection. This copy will be reviewed and returned **[after final inspection]**, with Architect/Engineer **[Construction Manager]** comments. Revise content of all document sets as required prior to final submission.
- D. Submit these sets of revised final volumes in final form within **10** days after final review comments are received.

2 PRODUCTS

Not Used.

3 EXECUTION

Not Used.

END OF SECTION

Section 01740

WARRANTIES

1 PART 1 GENERAL

1.1 SECTION INCLUDES

- A. Form of Submittals.
- B. Preparation and Submittal of Warranties.
- C. Time of Submittals.

1.2 RELATED SECTIONS

- A. **[Documents 00700 – General Conditions -- [00700CM – General Conditions -]
[Construction Manager @ Risk form (CM@Risk) – General Conditions]**
- B. Section 01700 – Contract Closeout.
- C. Section 01730 – Operation and Maintenance Data.
- D. Individual Specifications Sections: Warranties required for specific Products or Work.

1.3 FORM OF SUBMITTALS

- A. The Contractor shall provide the Owner all product Warranties and Guarantees.
- B. The Contactor shall deliver to the Architect upon completion of all work under the Contract, his written guarantee made out to the Owner on the Contractor's Letterhead, in the form included at the end of this section. This guarantee shall be made to cover the minimum period specified in **[Section 24] [Article 2]** of the General Conditions of the Construction Agreement.
- C. Guarantees from Contractor shall be supported by individual guarantees from each trade or subcontractor and manufacturer or supplier covering work. Where specific sections of the specifications call for longer guarantees, those specification sections shall be referenced in the second paragraph of the guarantee.
- D. Bind in commercial quality 8 ½ x 11 inch 3-ring binders with durable covers.
- E. Cover: Identify each binder with typed or printed title WARRANTIES AND GUARANTEES with title of Project; name, address and telephone number of Contractor and equipment supplier and name of responsible company principal.
- F. Table of Contents: Neatly typed, in the sequence of the Table of Contents of the Project Manual, with each item identified with the number and title of the specification section in which specified, and the name of Product or work item.

- G. Separate each warranty or guarantee with index tab sheets keyed to the Table of Contents listing. Provide full information, using separate typed sheets as necessary. List Subcontractors, supplier, and manufacturer, with name, address, and telephone number of responsible principal.

1.4 PREPARATION OF SUBMITTALS

- A. Obtain warranties and guarantees executed in triplicate by responsible Subcontractors, suppliers, and manufacturers, within time frame specified in Section 01700. Except for items put into use with Owner's permission, leave date of beginning of time of warranty until the Date of Substantial Completion is determined.
- B. Verify that documents are in proper form, contain full information, and are notarized.
- C. Co-execute submittal when required.
- D. Retain warranties and guarantees until time specified for submittal.

1.5 TIME OF SUBMITTALS

- A. For equipment or component parts of equipment put into service during construction with Owner's permission, submit documents within ten days after final acceptance.
- B. Make other submittals within time frame specified in Section 01700.
- C. For items of Work for which acceptance is delayed beyond Date of Substantial Completion, submit within days after acceptance, listing the date of acceptance as the beginning of the warranty period.

2 PART 2 PRODUCTS

Not Used.

3 PART 3 EXECUTION

Not Used.

END OF SECTION

DIVISION 1

UA No.

Section 01741

Warranty

WRITTEN WARRANTY FOR _____
(Entire Work, in the case of the Contractor, or Specific Specification SECTION (S) in the case of a Subcontractor or Supplier)

Name and address of Owner
Re: (Title of Project)

Date: _____

Gentlemen:

The undersigned firm(s), hereby warrant(s) that the (description of work covered) _____ which it/they have provided for the (Owner's project title and number) _____ has been completed in accordance with the requirements of the Contract Documents.

The undersigned firm(s) hereby warrantee the Owner that it/they will be responsible for defective materials, equipment, and workmanship, and further agree to repair or replace any or all of the referenced Work, as may be required to make it conform to the Contract Documents, together with any other adjacent work displaced or damaged by so doing, which may prove to be defective in its workmanship or materials in accordance with the provisions of **[Section(s) _____ and _____ of the Specifications and] [Section 24] [Article 2.7]** of the General Conditions of the Construction Agreement, ordinary wear and tear and unusual abuse or neglect excepted.

The undersigned firm(s) also agree(s) to repair any and all damages resulting from such defective work.

In the event of failure by the undersigned firm(s) to comply with the above-mentioned conditions within a reasonable time, not to exceed 14 calendar days, after being notified in writing by the Owner, the firm(s) collectively and separately, do hereby authorize the Owner to have said defective Work and damages repaired or replaced and made good at its/their expense, and will honor and pay the costs and charges therefore upon demand.

SIGNED _____

(Contractor's name, address, license number, and date of signing)

Attest: _____

or

SIGNED _____

(Subcontractor's name, address, license number, and date of signing)

Attest: _____

NOTE: All Signatures must be Notarized

Section 01810

GENERAL COMMISSIONING REQUIREMENTS

GENERAL

1.1 REFERENCE

- A. The Work under this Section is subject to requirements of the Contract Documents including the General Conditions, Supplementary Conditions, and sections under Division 1 General Requirements.

1.2 DESCRIPTION

- A. This Section will delineate the requirements of the Contractor and Installation Contractors in the execution of the commissioning process.
- B. Commissioning (Cx) is the process of ensuring that all building systems are installed and perform interactively according to the design intent, meet the Owner's operational needs, the installation is adequately documented and the building system Operations and Maintenance staff are adequately trained. It establishes testing and communication protocols to advance the building systems from installation to full dynamic operation and optimization.
- C. The Contractor verifies installation, provides scheduling and coordination of commissioning activities with sub-contractors, performs training, starts up equipment, conducts functional performance testing, corrects deficiencies, performs retests, and provides documentation of the effort. Contractor is expected to verify the functional readiness of systems to be tested prior to scheduling and demonstrating the functional operational performance in the presence of the Commissioning Agent (CA).
- D. The CA works with the Contractors and the A/E to direct and oversee the Cx process and witness functional performance testing.
- E. A Commissioning Plan will be developed by the CA outlining the Commissioning Process as detailed in the project specifications. The plan also identifies the roles and responsibilities of the other project team members. The plan will be updated regularly and redistributed to the commissioning team for review and comment. The intent of this plan is to evoke questions, expose issues, and resolve them with input from the entire commissioning team early in construction.

1.3 RELATED SECTIONS

- A. Division 7 – Thermal and Moisture Protection
- B. Division 15 – Mechanical Systems
- C. Division 16 – Electrical Systems

Section 01810**GENERAL COMMISSIONING REQUIREMENTS**

1.4 SYSTEMS IN COMMISSIONING PROGRAM

- A. Building Envelope including roof system
- B. HVAC Mechanical Equipment including air handling units, fan coil units, and zone temperature control
- C. Chilled Water System
- D. Steam and Condensate System
- E. General and Laboratory Exhaust Systems
- F. Building Automation System
- G. Potable Water and Waste Systems
- H. High Purity Water System
- I. Laboratory Process Systems including vacuum, compressed air, industrial water and process cooling water
- J. Electrical Distribution Primary Switchgear and Unit Substations
- K. Emergency Power and Lighting Systems including emergency generator
- L. Automatic Fire Suppression System including fire pump

1.5 COORDINATION

- A. Commissioning Team:
 - 1. Members of the Commissioning Team (CT) will consist of:
 - a. Commissioning Agent (CA)
 - b. Owner's Representative(s) (OR)
 - c. Contractor
 - d. Design Professional (A/E)
 - e. Mechanical Contractor (MC)
 - f. Electrical Contractor (EC)
 - g. Test and Balance Contractor (TAB)
 - h. Controls Contractor (CC)
 - i. Equipment Suppliers and Vendors
- B. A majority of the Contractor's effort supporting the Commissioning Program are activities that are typically required for a project that does not include formal commissioning. There are several specific tasks included in the Commissioning Program that do require an increased level of effort:

Section 01810

GENERAL COMMISSIONING REQUIREMENTS

1. Installation verification and start-up documentation. The Contractor is responsible for installation in accordance with applicable code, plans, specifications and industry standards and practices. The documentation of installation and start-up is part of the Project Quality Assurance Program
 2. Functional Performance Testing. Provided the installation verification and start-up documentation was properly completed, the involvement of installation contractors during the functional performance testing is minimal except as noted herein. The primary contractors involved in the functional performance testing is the Controls Contractor and the Test, Adjust and Balance Contractor. The anticipated level of involvement for these two contractors are defined in Division 15. The involvement of the Plumbing Contractor for systems included in the Commissioning Program will also be defined in Division 15. The involvement of the Electrical Contractor for systems included in the Commissioning Program will be defined in Division 16.
 3. Training. As specified in the technical sections of this specification, Contractors are responsible for providing training to the building operators. The CA will work with the Owner's Facility Management Department to define the areas of focus for the training and then it will be the Contractors responsibility to develop the training lesson plans and execute the training.
 4. Participate in regularly scheduled commissioning meetings. In order to coordinate the commissioning activities, the CA will conduct regular commissioning meetings. These would typically follow a project progress meeting.
- C. The CA will witness start-up and functional testing activities as specified in this Section. The OR may elect to also witness activities on a case-by-case basis.
- D. Contractor will provide written timely notice to OR of any changes in date, time, location or anticipated duration of start-up and test activities. For the purpose of this paragraph written notice shall be received by Owner's Representative a minimum of 72 hours in advance to be considered timely.
- E. Contractor shall reimburse Owner for actual costs incurred by the Owner as the result of failure to provide timely notice, per preceding paragraph, of changes in date, time, location, or anticipated duration of start-up and test activities.
- F. Management:
1. The Owner will provide the services of the CA. The CA directs and coordinates commissioning activities and reports to OR. All members of the Commissioning Team work together to fulfill contracted responsibilities and objectives of the Contract Documents.
- G. Commissioning Meetings:
1. Within 90 days following the start of construction and concurrent with pre-installation meetings with the contractors, the CA will plan, schedule, and conduct a commissioning kickoff meeting. Responsibilities of the commissioning team will be clarified at this meeting. The CA will distribute meeting minutes to all parties.

Section 01810

GENERAL COMMISSIONING REQUIREMENTS

2. Commissioning meetings will be held on a monthly basis as a minimum. The frequency of these meetings will increase as construction and acceptance activities require. Contractors are to designate a primary commissioning representative who will be responsible for attending the meetings, as required. Commissioning meetings will typically be scheduled following the weekly project meetings. Prior to the meeting, the CA will notify which commissioning representatives are required to participate in the meeting.

H. Scheduling:

1. In cooperation with the CA, the Contractor will integrate commissioning activities into the master construction schedule. This integration of commissioning activities, in general terms, will be developed early in the project and then refined as the project progresses.
2. Scheduling issues will be resolved at monthly commissioning meetings.
3. The CA will provide an initial schedule of primary commissioning events at the commissioning kick-off meeting. As construction progresses, more specific activities and milestones will be incorporated into the master construction schedule.

1.6 DEFINITIONS

- A. Acceptance Phase: Phase of construction after startup and initial checkout when Functional Performance Testing, O&M documentation review, and facility and user training occurs.
- B. Basis of Design: Documentation of design criteria and decisions made to meet design intent. Describes systems, components, conditions, and methods chosen to define the intent of the Owner.
- C. Commissioning Agent (CA): The consultant who directs and coordinates day-to-day commissioning activities. The CA reports directly to the Owner.
- D. Commissioning Plan: Overall plan that provides structure means of scheduling and coordination for the commissioning process
- E. Commissioning Team: Owner, Commissioning Agent, Contractor and Division Contractors.
- F. Construction Manager (CM): Owner's representative for management and coordination of construction activities.
- G. Deferred Functional Test: Functional test performed after substantial completion due to conditions that preclude test from being performed in normal sequential order of project delivery.
- H. Deficiency: Condition of a component, piece of equipment, or system that is not in compliance with Contract Documents (That is, does not perform properly or does not comply with design intent.)
- I. Design Professional (A/E) : The design team, generally the Architect, HVAC Mechanical Engineer and Electrical Engineer.
- J. Factory Testing: Testing of equipment at factory by the Manufacturer.

Section 01810

GENERAL COMMISSIONING REQUIREMENTS

- K. Functional Performance Test (FPT): Test of dynamic function and operation of equipment and systems. Systems are tested under various modes, such as during low cooling or heating loads, high loads, component failures, unoccupied, varying outside air temperatures, fire alarm, power failure, etc. Systems are run through all specified sequences of operation. Components are verified to be responding in accordance with contract documents. CA develops Functional Performance Test procedures in sequential written form, coordinates, oversees and documents actual testing, which is usually performed by installing contractor or vendor. Functional Performance Tests are executed after installation checklists and startups are complete. FPT's are conducted only after the completed IV documentation has been submitted to the CA.
- L. Functional Performance Test Procedures: Protocols and instructions described in the Commissioning Plan and specifications that describe process required to document the demonstration of functional operational performance.
- M. Indirect Indicator: Indicator of a response or condition by a secondary intangible method, such as a reading from a control system graphical interface reporting some device to be in some state.
- N. Installation Contractor: Contractor responsible for coordinating the installation and start-up of equipment, components and systems. May include sub-contractors from other trades to complete the installation.
- O. Installation Verification and Start-Up Checklist (IV): List of items to inspect and elementary component tests that verify proper installation of equipment. The checklists are primarily static inspections and procedures to prepare equipment or system for initial operation (e.g., belt tension, oil levels, labels affixed, gages in place, sensors calibrated, etc.) The IV document that will eventually be submitted to the Owner, the A/E and the CA will be a coordinated document representing the efforts of all subcontractors and the Contractor. Since this documentation is part of the Project Quality Assurance Program, the Contractor shall be responsible for compiling this information.
- P. Monitoring: Recording of parameters (flow, current, status, pressure, etc.) of equipment operation using data loggers or trending capabilities of control systems.
- Q. Non-Compliance: See Deficiency.
- R. Non-Conformance: See Deficiency.
- S. Over-written Value: "Writing" over a sensor value in control system to verify proper response of a system (e.g., changing outside air temperature value from 50°F to 75°F to verify economizer operation). See also "Simulated Signal".
- T. Over-ridden Value: "Writing over" of a set point or constant operating parameter during functional testing to instigate a mode or reaction in a system to prove operation.
- U. Phased Commissioning: Commissioning completed in phases due to size of structure, construction phasing, availability of systems, etc.

Section 01810**GENERAL COMMISSIONING REQUIREMENTS**

- V. Seasonal Performance Test: Functional Performance Test executed at the time of year such that system(s) experience conditions closer to design conditions.
- W. Simulated Condition: Condition created for testing component or system (e.g., applying heat to space temperature sensor to monitor response of VAV box).
- X. Simulated Signal: Disconnecting sensor and using signal generator to send amperage, resistance, or pressure to transducer and/or DDC system to simulate sensor value.
- Y. Specifications: Construction specifications of Contract Documents.
- Z. Startup: Initial start or activation of dynamic equipment, including executing Installation Verification and Start-up Checklists.
- AA. Sub-contractor: Contractors under contract to installation contractors who provide and/or install building components and systems.
- BB. Trending: Monitoring controls points of systems as a function of time using building control system.
- CC. Vendor: Supplier of equipment.

1.7 SUBMITTALS

- A. General: Submit the following in accordance with Conditions of the Contract and Division 01 Specification Sections.
- B. Start-Up Plan: For each piece of equipment or system submit a start-up plan to the OR for review by the A/E and the CA. Obtain approval of the plan prior to beginning activities. The plan should include, but not be limited to, the following:
 - 1. Start-up schedule
 - 2. Names of firms/individuals required to participate
- C. Start-up procedures: As part of the project quality assurance plan, the Contractor shall utilize installation verification and start-up checklists and data forms, developed by the CA, to document the installation and start-up of the various system components and equipment. Contractors shall review these documents and submit manufacturer, start-up documentation, as appropriate, for inclusion in the forms required for installation verification and start-up.
- D. Preliminary Systems Operations and Maintenance (O&M) Data: Once the contractor's equipment and system component submittals are reviewed and approved by the A/E, but no later than six months prior to substantial completion, the contractor shall submit preliminary Systems O&M data to the CM, in the format specified in Section 01815. The installation contractors shall be required to provide the O&M documentation to the Contractor in sufficient time for the Contractor to compile and submit the manuals to the CA for review and comment. The documentation provided to the CA shall be used to develop the training requirements for the equipment.

Section 01810**GENERAL COMMISSIONING REQUIREMENTS**

- E. The CA will review submittals for criteria as related to commissioning. Review is primarily intended to aid in development of functional testing procedures and secondarily to verify compliance with equipment specifications. The CA notifies Contractor, OR, and A/E of missing items or where issues may exist.

1.8 SEQUENCING AND SCHEDULING

- A. In order to expedite the close out of the facility, various systems can be in various stages of the commissioning process. CA and Contractor shall cooperate to schedule the Cx tasks to minimize the duration of the Cx activities.
- B. Cx Scheduling: Contractor shall incorporate the commissioning process into the project schedule. Start-Up, TAB, and Functional Performance Testing shall be itemized as applicable for each system/area. CA will dictate duration for the tasks.
- C. The satisfactory completion of the functional performance testing of the building systems in the Commissioning Program is a requirement for Substantial Completion of the work. For planning purposes, it is anticipated that the functional performance testing period will occur during the last six weeks prior to Substantial Completion. All building systems included in the commissioning program shall be ready for functional performance testing including the completion of all prerequisite requirements for testing as stated in the specifications.
- D. Approximately six months prior to the start-up activities, a working session will be held to review construction and commissioning milestones with the contractors to ensure that all critical path items are identified and monitored.

PART 2 - PRODUCTS**2.1 TEST EQUIPMENT**

- A. Division contractors will provide all specialized tools, test equipment, and instruments required to execute startup, checkout, and functional performance testing of equipment under their contract.
- B. Test equipment will be of sufficient quality and accuracy to test and/or measure system performance according to specified tolerances. Test equipment is to have calibrated within the previous 12 months. Calibration will be NIST traceable. Equipment will be re-calibrated according to manufacturer's recommended intervals and when dropped or damaged. Calibration tags will be affixed or certificates be readily available. The accuracy of the test equipment used to verify calibration shall be equal or greater than the specified sensor/device accuracy.

PART 3 - EXECUTION**3.1 COMMISSIONING PROCEDURE**

- A. Sequence of testing: Commissioning shall proceed from lower to higher levels of complexity. For each discrete subsystem or system, testing at the lower level shall be completed prior to starting the next higher level of tests. In general, the order of testing, from lowest to highest is as follows:

Section 01810

GENERAL COMMISSIONING REQUIREMENTS

1. Static tests (e.g. duct leakage tests, meggar tests). Typically, the Owner's Representative, CA and Contractor will witness the initial static tests to establish the standard for testing and the acceptance criteria. The sub-contractors shall then be responsible for conducting future tests in accordance with this standard. Periodically, the Owner's Representative and/or the CA may observe future tests.
 2. Component installation verification (i.e. motors, actuators and sensors) and start-up
 3. System Balancing
 4. System functional performance tests
 5. Intersystem functional performance tests
- B. Retesting: Repeat, at no additional cost to the Owner, the complete functional test procedure for each test in which acceptable results are not achieved and the failed test is due to the contractor's action or non-conformance to contract requirements. Repeat tests until acceptable results are achieved. Compensate the Owner for direct costs incurred as the result of tests repeated to achieve acceptable results, if the requirement for retesting is a direct result of the contractor's action or non-conformance to contract requirements.
- C. Correction of deficiencies
1. Correct functional performance test deficiencies promptly and schedule retest.
 2. Corrections during functional performance tests are generally prohibited to avoid consuming the time of personnel waiting for the test, but not involved in making the correction. Exceptions will be allowed if the cause of the failure is obvious and corrective action can be completed in a timeframe acceptable to the CA. If corrections are made under this exception, the failure shall be noted on the functional performance test data form. A new functional performance test data form, marked "retest," shall be initiated after the correction has been made. The entire functional performance test procedure shall be repeated.

3.2 PARTICIPATION IN COMMISSIONING

- A. Provide skilled technicians, and manufacturer representatives as appropriate, to start up systems.
1. These same sub-contractor technicians shall be made available to assist the CA in completing the commissioning program as it relates to each system and their technical specialty.
 2. Work schedules, time required for testing, etc., will be coordinated by the Contractor to ensure that all work is completed and ready for functional performance testing six weeks prior to substantial completion.
 3. Contractor will ensure that qualified technician(s) are available and present during the agreed-upon schedules and for sufficient duration to complete the necessary tests, adjustment, and problem resolutions.
 4. System problems and discrepancies may require additional technician time which shall be made available for the subsequent commissioning periods until required system performance is obtained.

Section 01810**GENERAL COMMISSIONING REQUIREMENTS**

- 3.3 The CA reserves the right to judge the appropriateness and qualifications of the technicians relative to each item of equipment or system. Such qualifications include expert knowledge relative to the specific equipment involved, adequate documentation and tools to service/commission the equipment, and an attitude/willingness to work with the CA to get the job done.
- 3.4 **INSTALLATION VERIFICATION**
- A. Before system start-up begins, conduct a final installation verification audit. The Contractor shall be responsible for completion of all work, including change orders and punch list items, to the satisfaction of the Owner's Representative.
 - B. If any work is found to be incomplete, inaccessible, incorrect, or non-functional, make note of deficiencies, and correct deficiencies before system start-up work proceeds.
- 3.5 **SYSTEM START-UP**
- A. Develop a start-up plan. The start-up plan shall be developed by the Contractor in coordination with the sub-contractors, taking into consideration the construction and commissioning milestones that have to be met in order to reach substantial completion. Commence with system start-up after approval has been given to the start-up plan and the pre-start-up inspection has been completed. The Contractor shall document the start-up activities on the approved start-up forms and list all system and equipment deficiencies noted during start-up. The Contractor shall take corrective action on all system deficiencies noted and demonstrate to the CA, if requested, suitable system operation. Notify CA and A/E of start-up activities' schedule at least 72 hours in advance. CA may physically witness selected start-up procedures. Should the CA witness a start-up procedure, the Contractor shall obtain signature of the CA indicating successful start-up.
- 3.6 **START-UP DEFICIENCY LISTS**
- A. Prepare Start-up Deficiency List forms to report deficiencies discovered in conjunction with system start-up. Start-up deficiency forms shall indicate the system being started-up, the location and identification of the deficient equipment/material, date of observation; initials of the observer; observed deficiency; date of correction; initials of person making the correction; and corrective action taken. The Contractor will be responsible for incorporating the start-up deficiencies identified by the responsible sub-contractor into a Master Start-up Deficiency Log that will be tracked utilizing the ProLog system.
 - B. Issue weekly Start-up Deficiency Report updates to the Contractor indicating corrective action and follow-up activities. The Contractor shall advise the CA when all start-up deficiency list items have been corrected on a specific piece of equipment or system component.
- 3.7 **FUNCTIONAL PERFORMANCE TESTING**
- A. Participation: CA will coordinate and witness functional performance tests after successful start up, documentation of systems and equipment installation, and testing and balancing is complete. The CA will coordinate with the Contractor to ensure that commissioning milestones do not impact construction milestones and to ensure that the commissioning activities are completed prior to Substantial Completion. The Contractor will generally execute test by manipulation of systems or

Section 01810

GENERAL COMMISSIONING REQUIREMENTS

- equipment, provision of supporting equipment or materials (lifts, ladders, specialty test equipment, etc.), and on spot remediation of minor identified deficiencies.
- B. Detailed Test Forms: CA will prepare detailed functional performance test (FPT) protocols for functionally testing systems. These will be developed during the construction phase and completed during the acceptance phase. The protocols will be reviewed with the involved parties (e.g. installation contractor, controls contractor, test and balance contractor, etc.) at least four weeks prior to the scheduled testing to ensure the involved parties clearly understand the procedures, level of involvement and scope of testing prior to the actual system operational demonstration.
- C. Completeness: All systems must be completed and ready for FPT.
- D. Test Documentation: CA will witness functional testing of systems. CA will record test results on the forms developed for the testing. CA will Pass or Fail the testing and record the date and time of the test. Deficiencies shall clearly be indicated when the test is failed. When all related testing is completed successfully, CA shall recommend acceptance of the system or component.
- E. Deficiencies and Re-testing: When deficiencies are identified during testing, depending on their extent or magnitude, they can be corrected during the test and the testing can continue to successful completion without significant delay. More significant deficiencies will require failure of the test and re-testing. Deficiencies of this magnitude will result in an action item on the Action List. The Contractor will then subsequently track the resolution of the deficiency via the Action List. All tests shall be repeated until successful completion.
- F. Sampling: Some types of identical equipment (such as terminal devices) will be tested using a sampling strategy.
- G. Failure Limit on Sample Tests: An acceptable failure limit will be established for each type of equipment where sampling is used. This limit indicates the maximum percentage of tested devices that may have any test that fails before an entirely new sample must be tested. This is based on the concept that if many failures occur, it is a result of inadequate start-up. When the maximum number of failures is reached, testing on that sample will be terminated and re-testing will be scheduled.
1. Where sample tests involve multiple systems, the maximum failure limit will apply per system.
 2. All work necessitated by sample failures shall be at no cost to the Owner
 3. For laboratory spaces, if a sampling strategy is conducted, the acceptance criteria shall be a zero failure rate. For support spaces, offices and educational classrooms (other than laboratories), if a sampling strategy is conducted, the acceptance criteria shall be a maximum of ten percent failure rate for total parameters that are sampled.
- H. Opposite Season Testing: Testing procedures shall be repeated and/or conducted as necessary during appropriate seasons. "Opposite season" testing is primarily for environmental systems and will be required where scheduling prohibits thorough testing in all modes of operation. Air Handler and Central heating system testing for heating related modes of operation and control loops shall

Section 01810

GENERAL COMMISSIONING REQUIREMENTS

be tested during outside air temperatures below 40°F. The CA will schedule the opposite season testing during the warranty period to coincide with a design day condition when possible.

- I. Acceptance Criteria: Acceptance criteria for construction installation tests (e.g. duct leakage tests, pipe pressure tests, pipe cleaning, electrical acceptance testing, etc.) is very important. The acceptance criteria where applicable will be specified in the individual sections. Documentation of the testing is to be provided to the CA prior to FPT.
- J. Additional information regarding functional performance testing is found in Division 7, 15 and 16.

3.8 TRAINING

- A. Prepare and submit for approval a training plan. Training plan shall include for each training session the following:
 - 1. Dates, start and finish times, and locations
 - 2. Outline of the information to be presented
 - 3. Names and qualifications of the presenters
 - 4. List of texts and other materials required to support training
- B. Contractors, Subcontractor, Vendors, etc. shall prepare and conduct training sessions on the installed systems and equipment they are responsible for. Generally the CA and A/E shall conduct systems overview, design intent, and design criteria training. The Contractors and Vendors shall perform all other training as previously described. The training agenda, content and number of training sessions will be incorporated into a training plan prepared by the Contractor.
- C. Contractor shall compile training plans of contractors, subs, and vendors and present a comprehensive training plan.
- D. Training sessions should typically start and end in a classroom setting. Field demonstrations will also typically be conducted to demonstrate the hands-on aspects of the required tasks.
- E. Appropriate contractor or vendor shall instruct the Owner's designated representative(s) on the safe and proper operation, maintenance, diagnosis, and repair of each piece of specific equipment. Submitted operation and maintenance information shall be used during training. Sessions shall include as a minimum:
 - 1. Conceptual overview of how the equipment works.
 - 2. Names, addresses, numbers etc. of sources for information, tools, spare parts, etc. for the equipment.
 - 3. Details of the warranty or guarantee.
 - 4. Intended sequences of operation in all modes of operation.
 - 5. Sources of utility support.
 - 6. Routine operator tasks involving monitoring and operation covering all modes of operation and mode switching as applicable.
 - 7. Relevant health and safety practices/concerns.

Section 01810

GENERAL COMMISSIONING REQUIREMENTS

8. Common problems and their diagnosis and repair.
9. Proper maintenance schedules, tasks and procedures with demonstrations.
10. Emergency response, documentation and recovery procedures.

F. Minimum Training

1. A three tiered training approach will be employed as follows:
 - a. Tier 1 System Overview (by A/E) – To describe overall system concepts and design intent.
 - b. Tier 2 Component Training (by installing contractor) – To describe detailed component.
 - c. Tier 3 Specific Equipment Training (by installing contractor and manufacturer) – To describe detailed specifics of individual pieces of equipment (such as VFD's).
 - d. Specific training requirements are found in the appropriate Division 15 and 16 sections.

G. Training is to be expense of the contractor and/or the manufacturer.

H. In addition to the verbal instructions outlined above, the Contractor and the manufacturer's representatives and subcontractors shall furnish written basic instructions indicating the proper operation of each system and associated equipment. Each manufacturer shall also submit maintenance guidelines, in a format defined by the Owner and the Commissioning Agent, on the equipment including instructions on operation, lubrication, recommended spare parts and instruction on preventive, routine and corrective maintenance and equipment troubleshooting.

I. The written instructions and manufacturer's equipment maintenance guidelines that will be used as handouts for the training session shall be bound and ten (10) copies of the training documentation provided for the training. In addition, three(3) copies of the Systems Operations and Maintenance Manuals will be available during the training session.

J. Training shall include both classroom and on-site hands-on system instruction. Training in the classroom setting will utilize the operations and maintenance manuals and appropriate schematics, handouts, and audio/visual training aids.

K. The Owner has the right to videotape training sessions for use in staff orientation training in the future.

3.9 TEMPORARY CONDITIONS AND PHASED CONSTRUCTION

A. As the construction progresses it may be necessary to utilize building systems for temporary environmental control within the building. Should systems be used for temporary environmental control, this activity shall be sequenced into the system delivery process and involve temporary start-up and functional operations testing. Temporary conditions will not be fully functionally tested to the extent that a duplication of effort must occur for final delivery to the Owner, once the system is fully operational and balanced. Temporary conditions must, at a minimum, meet the intent of the documentation regarding functionality, fluid flow rates and space pressurization. The sub-contractor shall utilize the installation verification and start-up forms for documenting the readiness of the system to be temporarily operated. The contractor will be responsible to verify that all temporary conditions meet the requirements of the design documents.

Section 01810

GENERAL COMMISSIONING REQUIREMENTS

- B. Should the temporary operation of the system include a Sequence of Operations that does not conform fully to the contract requirements, this temporary Sequence of Operations shall be submitted for review and approval prior to energizing and operating the system in the temporary mode.
- C. A formal verification process for temporary systems will be at the discretion of the Owner and the A/E in the event the need becomes apparent. A formal process is defined as the responsible contractor demonstrating comprehensive functionality to a representative of the Owner, CA or A/E. The Owner will not bear additional cost for this demonstration and the demonstration will occur at the request of the Owner or A/E.
- D. The above applies to systems that serve areas of phased construction. Testing will occur piecewise as determined prudent by the project team for conditions of a system considered to be permanent. The intent is to not repeat the formal functional testing process on a system except as deemed prudent for effective delivery by the Owner and A/E.
- E. These stipulations do not apply to the TAB process. The systems and spaces will meet the intent and requirements of the design documents for each subsequent phase or temporary condition as defined in the design documents.

3.10 RESPONSIBILITIES

- A. Responsibilities of contractors are provided as follows (see the project Commissioning Plan for a comprehensive list of responsibilities of all project parties):
 - 1. Contractor:
 - a. Include requirements for commissioning in each purchase order or subcontract written.
 - b. Attend commissioning kick-off meeting and other commissioning team meetings.
 - c. Perform required review of Contractor submittals.
 - d. Submit copy of approved submittals with startup, operating and maintenance criteria to CA.
 - e. Facilitate coordination of commissioning activities as directed by CA.
 - f. Incorporate commissioning activities including functional performance testing into master construction schedule. Contractor shall be responsible for maintaining schedule document such that it is an accurate representation of construction progress through the completion of functional performance testing and resolution of all punch list issues.
 - g. Incorporate milestone durations into construction schedule to review system installation progress with appropriate contractor. (Progress is documented to PC and reflected in project schedule.)
 - h. Incorporate durations into construction schedule per each system completion to administer Functional Performance Testing.
 - i. Review Commissioning Plan and Functional Performance Test procedures developed by CA.
 - j. Incorporate durations into construction schedule per each system to administer system training.

Section 01810

GENERAL COMMISSIONING REQUIREMENTS

- k. Take active role in coordinating completion and documentation of Installation Verification and Start-Up Checklist.
 - l. Coordinate this activity with knowledgeable staff of contractors and submit single comprehensive document to CA.
 - m. Submit detailed training plan to CA for approval.
 - n. Provide CA with required documentation from commissioning activities and submittal request.
 - o. Manage the submission and review of Installation Verification and Start-Up Checklists as outlined in this specification.
 - p. Forward completed Installation Verification and Start-Up Checklist to CA at least 5 workdays prior to scheduled FPT.
 - q. Schedule, coordinate and assist CA in seasonal or deferred testing and deficiency corrections required by specifications.
 - r. Maintain and keep current all information sharing (e.g. deficiency lists, field observation punchlists, etc.) and project scheduling and documentation in the ProLog Construction Manager software.
2. Installation Contractors and Sub-Contractors:
- a. Attend commissioning kick-off meeting and other commissioning team meetings scheduled by CA. Assign a primary commissioning representative who will be responsible for participating in commissioning meetings and other commissioning related activities as appropriate.
 - b. Assist Contractor and CA with developing a comprehensive commissioning schedule during regularly scheduled commissioning meetings.
 - c. Complete commissioning activities as scheduled in master construction schedule.
 - d. Provide certified and calibrated instrumentation required to take measurements of system and equipment performance during Functional Performance Testing.
 - e. Ensure installation work is complete, is in compliance with Contract Documents, and ready for Functional Performance Testing.
 - f. Execute inspections, tests, and Functional Performance Tests as described in contract documents and Commissioning Plan. Operate systems and equipment to demonstrate proper sequences of operation.
 - g. Complete Installation Verification and Start-Up Checklist in cooperation with Contractor and submit with supporting documentation.
 - h. Review Commissioning Plan and Functional Performance Test procedures.
 - i. Provide required training for Owner personnel as detailed in Part 3.7 of this Section and as specified in other technical specification sections.
 - j. Provide documentation according to contract documents.
 - k. Execute seasonal or deferred Functional Performance Testing.

Section 01810

GENERAL COMMISSIONING REQUIREMENTS

3. Controls Contractor:
 - a. Completely install and thoroughly inspect, startup, test, adjust, calibrate, and document systems and equipment under Building Automation/Controls Contract
 - b. Assist CA during Functional Performance Testing. Assistance will generally include the following:
 - 1) Attend Cx progress and coordination meetings
 - 2) Prepare and submit required draft forms and systems information.
 - 3) Provide trend logs of system operation at discretion of CA.
 - 4) Demonstrate system operation to the CA.
 - 5) Provide instrumentation necessary for verification and Functional Performance Testing.
 - 6) Manipulate control systems to facilitate verification and Functional Performance Testing.
 - 7) Train Owner's Representatives in system operation and control equipment use, operation, maintenance, and repair as detailed in Part 3.7 of this Section and as specified in other technical specification sections.
 - c. Provide onsite programmer to correct deficiencies in control sequences during the commissioning period.
4. Test Adjust Balance (TAB) Contractor:
 - a. Attend Commissioning meetings.
 - b. Submit Balancing Plan and forms describing the methodology for execution of the project.
 - c. Coordinate TAB work with EMCS contractor.
 - d. Rebalance deficient areas identified during commissioning.

3.11 COMMISSIONING TEAM MEETINGS

- A. Commissioning Team Meetings will be held periodically as determined by CA with frequency increasing as construction advances and systems become operational. Attendance of commissioning representative, as appropriate and as requested by the CA, is mandatory. CA will record minutes and attendance. CA will chair Commissioning Team Meetings.
- B. Discussions held in Commissioning Team Meetings will include but not be limited to system / equipment start-up, progress, scheduling, testing, documentation, training, deficiencies, and problem resolution.

3.12 INSTALLATION VERIFICATION (IV) AND START-UP CHECKLISTS

- A. Completion of IV checklists and startup procedures are directed by the Contractor in accordance with the Project Quality Assurance Program and executed by Sub-contractor. When checking off IV checklists, signatures are required by individuals of subcontractors or manufacturer's representatives with specific knowledge of completion of work.

Section 01810**GENERAL COMMISSIONING REQUIREMENTS**

- B. The IV checklists will be amended by the contractor to include start-up and static test documentation required by the manufacturer for a piece of equipment.
- C. The division contractor will maintain a “living” copy of an IV checklist for each piece of equipment. The master copy of the IV checklist will be attached to the specific piece of equipment to allow all trades to “sign off” on tasks for which they are responsible. The division contractor shall notify the other trades when the equipment/component is ready for sign off. These forms will be reviewed by the Owner’s Representative, A/E and CA, as appropriate, during scheduled site visits.
- D. At appropriate milestones, the Contractor will review the IV of each division contractor and record progress to the project IV checklist that will eventually be submitted to the Owner and CA.
- E. The IV review will be completed by field survey of each piece of equipment by the Contractor representative and the installing contractor. Contractor will document proper installation of equipment to IV checklist in the field with installing division contractor.
- F. The installing contractor will provide the individual with specific knowledge of the installation of respective equipment for this review.
- G. The Owner, A/E and Cx Team receive completed IV Checklist. CA performs random verification of checklist items and makes recommendation to Owner to proceed with FPT.
- H. CA reserves the right to witness any startup and preliminary equipment testing.
- I. Sub-contractor will execute startup and provide CA with signed and dated copy of completed start-up and IV checklists. Only individuals having direct knowledge a task was actually performed will initial or check respective item.
- J. Sub-contractor will clearly list outstanding items of initial start-up and installation items not completed successfully on IV Checklists.
- K. CA reviews report to determine if outstanding items prevent scheduling of Functional Performance Testing.
- L. Sub-Contractor will re-submit an updated IV Checklist with date of completion noted for completed items.

3.13 FUNCTIONAL PERFORMANCE TESTING**A. Objectives and Scope:**

1. The objective of Functional Performance Testing is to demonstrate each system is operating according to documented Basis of Design intent and Contract Documents. Functional Performance Testing facilitates bringing systems from a state of substantial completion to full dynamic operation. Additionally, during Functional Performance Testing, areas of deficient

Section 01810

GENERAL COMMISSIONING REQUIREMENTS

performance are identified and corrected the improving operation and functionality of systems.

2. Each system shall be operated through all modes of operation (seasonal, occupied, unoccupied, warm-up, cool-down, part- and full-load, etc.) where there is a specified system response. Verifying each sequence in the specified sequence of operation is required including responses to conditions such as power failure, freeze condition, low oil pressure, no flow, equipment failure, etc.
3. The contractor that is responsible for the dynamic operation of a system will demonstrate comprehensive functionality of that system. All contractors that have contributed to the installation of the same system will not be required to directly participate in the functional testing activity but will be required to be immediately available for reconciliation of issues that fall within their scope and responsibility during testing.

B. Development of Test Procedures:

1. The purpose of a test is to verify and document compliance with specified criteria and to meet the design intent of the project. The contents of a functional test will not be the limiting factor for acceptance of a system. The Cx team or source vendor will develop specific test procedures and forms to verify and document proper operation of each system. The contractor responsible for associated system or component will provide assistance to CA in finalizing test procedures (answering questions about equipment, operation, sequences, etc.).
2. Test forms for many systems are included in the bid documents and will be used as a basis for proving that systems meet the project requirements as defined in the design documents and the project intent documents. Other systems may require the vendor to provide test documentation at the time of product submittals for review by the A/E. See specifications for specific requirements for each system. The vendor is encouraged to utilize the test format provided at the project website for ease of review and subsequent approval by the A/E.
3. Test procedure forms will include, but not be limited to, the following information:
 - a. Project name
 - b. Date
 - c. System name
 - d. Equipment tags that make up systems
 - e. Participating parties
 - f. Required pre-test field measurements
 - g. Instructions for setting up test
 - h. Specific step-by-step procedures to execute test, in a clear, sequential, and repeatable format
 - i. Acceptance criteria of proper performance with a Yes / No check box to allow for clearly marking whether or not proper performance of each part of test was achieved
 - j. Section for comments
 - k. Signature and date block for participants
4. Coordination and Scheduling:

Section 01810

GENERAL COMMISSIONING REQUIREMENTS

- a. Functional and installation issues will be posted to the A/E's punch list and correction will follow protocol as described in the general conditions.
 5. When the contractor completes a system prior to the completion date as shown on the project schedule, the contractor may submit PC documentation and request review and initiation of FPT. Coordination and final scheduling confirmation of Functional Performance Testing will occur during regularly scheduled commissioning meetings. All commissioning activities will be fully integrated into the construction activity schedule. This includes milestone deadlines for completion of installation of major system components and the durations for functional testing of a system.
 6. CM will provide sufficient notice to CA regarding changes to the coordinated completion schedule for systems testing.
 7. CA will witness and document Functional Performance Testing of systems. Designated sub-contractor or vendor responsible for dynamic operation of a system or device will demonstrate system functionality to CA.
 8. Functional Performance Testing is conducted following completion of IV and Start-Up Checklists and associated start-up procedures as required by the manufacturer and design documents.
- C. Test Strategy
1. The responsible contractor will test all systems comprehensively.
 2. Systems that contain many repeated identical devices may be selected and demonstrated to the project team based on a sampling strategy.
 - a. The sample population for any group of identical devices that will undergo functional testing will be determined by the Owner and CA.

3.14 COMPLETION OF DOCUMENTATION

A. Documentation:

1. CA will witness and document results of FPT using procedural forms developed for that purpose. CA will include FPT documentation in final Commissioning report as an appendix to the final report.

B. Non-Conformance:

1. CA will document results of Functional Performance Test to FPT forms. Deficiency or non-conformance issues will be noted and reported to commissioning team as a punch list item with specific responsibility indicated. The Functional Performance Test Discrepancy Report will be provided to the Contractor by the CA. The Contractor will be responsible for incorporating these discrepancy report items into ProLog and tracking completion.
2. Corrections of minor deficiencies identified may be made during testing at discretion of CA. In such case, deficiency and resolution will be documented on procedure form and to punch list as a resolved issue.
3. Every effort will be made to expedite testing and minimize unnecessary delays, while not compromising integrity of procedures.

Section 01810

GENERAL COMMISSIONING REQUIREMENTS

4. Deficiencies are handled in the following manner:
 - a. When there is no dispute on deficiency and Sub-contractor accepts responsibility for remedial action:
 - 1) CA documents deficiency and Sub-contractor's response and intention. CA posts issue to action list. Sub-contractor corrects deficiency and resubmits to commissioning team. Contractor addresses all issues noted on action list by correcting deficiencies or by posting date for completion of resolution of deficiency.
 - 2) Contractor reschedules test with CA, Sub-contractor. New test time is posted to project schedule.
 - b. When there is a dispute about a deficiency, regarding whether it is a deficiency or who is responsible:
 - 1) CA documents deficiency and Contractors response and testing proceeds on subsequent test or sequence. CA post issue to punch list and distributes to team.
 - 2) Contractor facilitates resolution of deficiency. Other parties are brought into discussions as needed. Final interpretive authority is with A/E. Final acceptance authority is with the Owner.
 - 3) CA documents resolution process.
 - 4) Once interpretation and resolution has been decided, appropriate party corrects deficiency, and CA is given notice to proceed for retest. Contractor and CA reschedule test. New test time is posted to project schedule.
- C. Cost of Retesting:
1. If the cause for retesting is construction related, the cost for sub-contractor to recheck IV checklist or re execute FPT will be borne by the sub-contractor.
 2. If the cause of retesting is not construction related (e.g. Design Issue) cost recovery for the sub-contractor for re-visitation will be negotiated with Contractor.
 3. Time for CA and Contractor to direct any retesting required because a specific IV checklist or start-up test item reported to have been successfully completed, but determined during Functional Performance Testing to be faulty, may be backcharged to Sub-contractor.
 4. Contractors and subcontractors may be held responsible for expenses incurred by owner for retesting due to their state of reported readiness or lack thereof as represented on the IV checklists. Expenses could include, but not be limited to, retesting labor costs, travel expenses, and remobilization for owner and consulting teams.
 5. CA notes each satisfactorily demonstrated function on test form. CA, Contractor, and Owner provide formal approval of FPT after review.

3.15 COMMISSIONING RECORD AND COMMISSIONING BINDER

- A. CA is responsible to compile, organize, and index commissioning data by equipment and deliver it to the Owner in Commissioning Binders. Some of the documentation compiled by the CA requires information from the sub-contractor. The Contractor shall be responsible for collecting the sub-

Section 01810**GENERAL COMMISSIONING REQUIREMENTS**

contractor information and providing this information to the CA. Commissioning Data to include the following:

1. Commissioning Plan
2. Final Commissioning Report
3. Startup plan and report, approvals, corrections, blank IV and Start-up Checklists
4. Completed Functional Performance Test documentation
5. Completed training plan with attendee record
6. Deficiency Log
7. Construction photo archive

3.16 FINAL REPORT DETAILS

A. Final commissioning report will include an executive summary, list of participants and roles, brief building description, overview of commissioning process and general description of test and verification methods. Some of the documentation compiled by the CA requires information from the sub-contractor. The Contractor shall be responsible for collecting the sub-contractor information and providing this information to the CA. For each piece of commissioned equipment, the report will contain disposition of commissioning agent regarding adequacy of equipment, documentation and training meeting contract documents in the following areas:

1. Equipment meeting equipment specifications
2. Equipment installation
3. Functional performance and efficiency
4. Equipment documentation and design intent, and
5. Operator training.

B. All outstanding non-compliance items will be specifically listed. Recommendations for improvement to equipment or operations, future actions, commissioning process changes, etc. will also be listed. Each non-compliance issue will be referenced to specific functional test, inspection, trend log, etc. where deficiency is documented. Functional performance and efficiency section for each piece of equipment will include brief description of verification method used (manual testing, BAS trend logs, data loggers, etc.) and includes observations and conclusions from testing.

3.17 DEFERRED TESTING

A. Unforeseen Deferred Tests:

1. Any check or test not completed due to building structure, required occupancy condition, or other deficiency, may be delayed upon approval of Owner. These tests will be conducted as soon as possible. Contractor shall provide support, as appropriate and requested by the CA, to satisfactorily complete the testing.

B. Seasonal Testing:

1. During warranty period, seasonal testing (tests delayed until weather conditions are closer to system's design) on the environmental systems (e.g. air handling units, chilled water system,

Section 01810

GENERAL COMMISSIONING REQUIREMENTS

etc.) will involve the installation contractor's for these systems. This contract. CA will coordinate this activity. Tests will be executed, documented and deficiencies corrected by appropriate contractor(s), with facilities staff and CA witnessing. CA will incorporate final updates to O&M manuals as necessary.

END OF SECTION

INTRODUCTION

This Manual of Design and Specification Standards is the result of a charter initiated by the Deputy Vice President for Facilities, Robert W. Hatch, in November 1993. A task force was then created to establish a process to develop, implement and maintain the use of new University of Arizona Design and Specification Standards in the design, renovation and maintenance of all facility related projects. The task force completed this mission in June 1994 and established a Standing Oversight Committee to oversee the development and implementation of this new Manual.

The primary function of the Oversight Committee is to establish the authority under which the new Manual of Design and Specification Standards (DSS Manual) will operate. The Oversight Committee is to maintain a consistent decision making and operating philosophy that integrates the best interests of the UA Facilities Group and the current design and construction industries. The Oversight Committee performs this critical function by supervising the Technical Sub-Committees, approving all drafts of the DSS Manual and entertains all revision requests submitted.

The technical content of this manual represents the culmination of input from many Technical Sub-Committees who reviewed previous UA Standard Guidelines and integrated current needs and practices. Although it is felt that this effort produced a more up to date listing of UA Design and Specification Standards, it is realized that improvements are always possible and that many iterations may be required to achieve perfection. To pursue this goal a procedure has been formalized to continuously receive input an issue revisions to the Manual on a regular basis.

The most important aspect of this DSS Manual is the process to evaluate and implement revisions. Consequently your attention is directed to the Request for Revision Forms included in this manual. Without your continued and valued input the content of the Manual would stagnate.

Appreciation should be given to the following individuals for their participation as the Oversight Committee and their efforts in the development and compilation of this Manual.

Brian Dolan	Facilities Design and Construction
Carl Gajdorus	Facilities Design and Construction
Bob Herman	Facilities Management
Lionel Jacobs	Facilities Management
George McFerron	Facilities Design and Construction

Acknowledgments should also be given to all those who participated in the Technical Sub-Committees for without their efforts this Manual would not be possible.

Bob Smith, Director
Facilities Design and Construction

Al Tarcola, Director
Facilities Management

MANUAL OF DESIGN AND SPECIFICATION STANDARDS
REQUEST FOR REVISION

Instructions:

1. Complete form in type written text or legible hand printing in black ink.
2. Be sure to include your name, department or firm and telephone number.
3. Provide as much justification for request as possible. Attach additional sheets if necessary and reference them on this form.
4. Please limit requests to one item or subject per form.
5. Mail completed form to: DSS Oversight Committee
 Attn: Brian Dolan
 University of Arizona
 Department of Planning, Design & Construction
 P.O. Box 210300 Tucson, AZ 85721-0300

Date: _____

From: _____

Telephone: _____

Please consider the following revision to the Manual of Design and Specification Standards. The nature of this request is (circle one):

Addition

Revision

Deletion

Section Number Reference: _____

Revision Requested (attach additional sheets if necessary):

Reason or Justification for Revision (attach additional sheets if necessary):

Section 16122 PRIMARY POWER CABLES

PART 1 GENERAL:

- **WORK INCLUDED**

The Contractor shall furnish and install all shielded power cable suitable for use on this project.

- **RELATED WORK**

Section 16020: Tests

- **SUBMITTALS**

The Contractor shall submit test and product data in accordance with Section OI 300.

PART 2 PRODUCTS:

Acceptable Manufacturer: Okonite Prysmiam, Southwire, or Kerite meeting these specifications is acceptable.

- **TYPE AND RATING**

The cable shall be certified for normal operation at a conductor temperature of 105 degrees C; in wet and dry locations; in conduit above and below ground; in exposed cable tray runs. Conductors shall also be certified for operation at 1 30°C during emergency conditions and 250°C under short circuit conditions. The cable insulating and jacketing materials shall have a forty year average service life.

All cable shall have the voltage ratings as hereinafter specified with ethylene propylene rubber insulation and suitably sized copper conductors. The cable shall be supplied in the quantities and number of conductors specified and for the functions as listed.

- **SHIELDED POWER CABLE**

Cable Type and Size	Voltage Rating
Copper Conductors Copper Foil Shield	15 kV - 133% Insulation

- **QUALITY ASSURANCE**

Each power cable shall be given the manufacturer's standard production tests to assure that all cables adequately meet the requirements of these specifications. All cable shall conform to the applicable requirements of ICEA Publication S-68-516, UL 1072, Federal Standard 10 CFR 50, and UL Type MV 105 EPR and the latest specifications for extruded insulation. The copper conductors shall conform to ASTM-B8 for annealed copper, Class B stranded, compressed concentric round.

Test data shall be furnished to the Owner. Test data may apply to the cables being furnished under this purchase order, or may be certified results of tests previously made on identical cables.

Materials used in the manufacture of the cable covered by these specifications shall be of the kind, composition and physical properties best adapted to their various purposes and conform to the standards of AEIC, ANSI, ASTM, IEEE, ICEA, NEC, NEMA and UL in effect on the date of the bid-opening as to material, workmanship, design and testing. Tolerances and practices in manufacture of finished cable shall conform to the best modern shop practices.

- **SPECIFIC SUBMITTAL REQUIREMENTS**

Materials Test Reports: Where specific materials tests are herein specified or where such tests are required by specific standard governing the manufacture of such materials, six (6) copies of certified test results shall be furnished by the manufacturer to the Contractor who shall submit them to the Owner.

The Contractor shall submit certified copies of the results of all standard production tests and tests performed in accordance with NEMA, and ICEA S-66-524 Standards as required by paragraph above, "Quality Assurance".

Technical Data: Contractor shall submit within 30 calendar days after receipt of Notice of Award values for all technical data regarding the cable being furnished.

- **DESIGN AND CONSTRUCTION**

Conductors: All copper conductors shall be stranded, and fabricated from uncoated, annealed copper wire conforming to ASTM B8. Stranding shall be concentric lay Class B, Standard, #2 cable.

Insulation: Conductors shall be insulated with ethylene propylene flexible thermosetting dielectric compound. The ethylene content of the compound shall not exceed 72% by weight of ethylene nor shall the compound contain any polyethylene. The insulation shall be triple-tandem extruded with the conductor and insulation screens. The extruded screen shall be free stripping. The outer screen/insulated core shall be covered with an uncoated copper tape. It shall be applied helically with 12.5% nominal overlap. The overall jacket shall be polyvinyl chloride.

Semi-Conductor Screens: These shall be Ethylpropylene based.

Identification: All cable shall have a permanent and readily identifiable exterior surface marking at appropriate intervals along its entire length. The method of marking shall be subject to the approval of the Owner. The marking shall contain the following information:

- Manufacturer
- Year of manufacture
- Size and type of conductor
- Rated voltage
- Insulation thickness
- Shield
- Type of jacket

Reels: All cable shall be furnished on reels. Each reel shall have the diameter of the drum large enough to prevent damage to the cable from reeling. The maximum flange diameter of the reel is not to exceed 78 inches. The outer end of the cable shall be securely fastened to the reel head so as to prevent the cable from becoming loose in transit. The inner end of the cable shall project into a slit in the side of the reel or into a housing on the inner side of the drum in such a way as to

make it available, if required, for test. The inner end shall be fastened to prevent it from becoming loose during installation. Each reel shall be plainly marked to indicate the direction in which it should be rolled to prevent loosening of the cable on the reel. The reels shall be lagged. Each length of cable shall be effectively sealed to prevent the entrance of moisture. The seal shall be applied in such a way as to prevent damage to the conductors or cable.

- **DATE OF MANUFACTURE**

All cable utilized in a pull shall have been manufactured during the same production run from the factory. All cable shall be new and shall have been manufactured within 3 months of the date of receipt at the job site. Storage of cable prior to installation shall comply with the recommendations of the manufacturer.

- **GUARANTEE**

The manufacturer of the cable shall furnish medium voltage cable which shall comply with the following warranty:

"The manufacturer shall warrant the cable to free from defects in material and workmanship for the 40 year design life of the cable; provided the cable is employed under the conditions contemplated and covered by the design specifications, and provided further that the cable is installed, spliced, terminated, maintained, and operated in accordance with the manufacturer's recommended procedures, at the time of bid.

In the event that the cable is defective in manufacture, as determined by the manufacturer and the University of Arizona jointly, the manufacturer's only responsibility will be to supply another cable for the defective portion, the new cable to be delivered free of charge to the University of Arizona.

Manufacturer shall not be responsible for any defects or repairs to, or replacement of, adjacent or connected equipment to which the cable may supply electric power or from which it may take electrical power or from which it may take electrical power. Manufacturer will not be responsible for any termination, maintenance, or operation which is not in accordance with the manufacturer's recommended standards and procedures."

PART 3 EXECUTION:

- **INSTALLATION**

Reels shall be rolled only in the direction indicated by the manufacturer and no reel containing cable shall be dropped from a truck or from any other comparable height, under any circumstances. In turning reels, particularly after the lagging has been removed, bars shall be used in such a manner that they will not bear against the cable. Reels shall not be rolled over rocks or other projecting objects which are liable to damage the cable and, when it is necessary to roll unlagged reels over soft ground, plant tracks shall be provided to keep the reel from sinking with possible damage to the cable. Cable shall be carefully handled during installation and shall be unreeled or uncoiled slowly to prevent damage to the insulation or sheath from sudden bending. The ends of any cable used shall be kept sealed from moisture at all times, either for cables that have been pulled and are awaiting connection, or for cables on reels in storage. In no case shall cables be allowed to lie on the floor or any other location where they may be subject to damage. If necessary, temporary supports shall be provided and arranged so as not to interfere with any provisions for permanent supports, or require any cable splicing. When reeling the cable

off of the reels and pulling it into the conduit every effort must be made to protect the cable from damage. The cable shall not be pulled off onto bare ground, asphalt, or concrete. Wherever it is required to pull cable off of the reel for a subpull it shall be necessary for the contractor to provide a surface which will not subject the cable to abrasion during the subpull.

Sharp kinks shall be avoided in any unreeling, uncoiling, and pulling operation, and the cable shall be carefully guided and trained into conduits or other raceways in as direct a manner as possible with a minimum amount of bending. The Contractor shall be responsible for keeping any cable bends to as large a radius as feasible and, where practicable, the minimum radius shall be kept at a value no less than 12 times the outer diameter of the insulation or covering. Where conditions dictate the installation, necessary bends of a small radius will be permitted, subject to the approval of THE UNIVERSITY OF ARIZONA. Any cable pulled in a manner resulting in damage to the shielding shall be removed and replaced at the direction of THE UNIVERSITY OF ARIZONA and at the Contractor's expense. Following the installation of the cable and until such time as the splice or stress cone is made the cable shall be resealed to prevent absorption of moisture into the insulation of the cable.

Before any cable is pulled in any conduit, such conduit shall have been tested for and cleared of, any obstruction in accordance with the requirements of Section 16115. The conduit termination shall be provided with a bushing or other suitable protector to guard against damage to the insulation or outside covering. Cable may be pulled by woven basket wire grips or by attachment of the pulling device directly to the conductor. Pulling tension shall not exceed the manufacturer's recommended limits. Soapstone, or other non-hardening pulling lubricant, approved by THE UNIVERSITY OF ARIZONA electrical engineer for the type of insulation involved, shall be used to help facilitate pulling requirements. All cable installed shall be arranged, and tied where necessary, in the opinion of THE UNIVERSITY OF ARIZONA, in a neat and orderly manner. Cable shall enter and leave in neat packs and shall be arranged in such a way as not to block openings or future use. The cables shall be supported clear of sharp edges or any structural framework. Cables shall be kept clear of any obstruction while placing. Cable installation procedures shall be reviewed by the U of A electrical engineer and shall be subject to the approval of the Owner.

Splices will not be permitted except where indicated on the drawings or where specifically approved by the engineer prior to start of work for high voltage cable. The Contractor shall furnish all materials and perform all work required for the complete termination or splicing of any wire, or cable including any stress cones that may be required. Terminations, splices and stress cones for high voltage cables and conductors shall be completed in accordance with manufacturer's recommendations or as directed by THE UNIVERSITY OF ARIZONA.

All high voltage cable splicing and dressing work shall be performed by men and crews thoroughly experienced (minimum five years) in such work, and each such cable splicer shall be approved by THE UNIVERSITY OF ARIZONA before splicing has begun. High voltage cable shall be given a high potential test per the requirements of section 16950 before final termination. Where desirable, the final termination taping shall be extended over the terminal connector onto the bus or bushing of the equipment to which the conductor is attached. Final taping shall generally be applied from bottom to top to provide the best possible shield and, in wet or damp locations, terminal taping shall be painted with insulating varnish. The Contractor may use premolded slip on type splices, taps and stress-cones. These premolded devices shall be made of ethylene propylene terpolymers. All cable splices shall be approved for use by the cable manufacturer on the specific cables.

DIVISION 16 ELECTRICAL

PROJECT NO.

Where T connections are approved by the UA Electrical Engineer, utilize bus bars with dead break elbow terminals and bushings. Use deadfront devices when they are available.

PART 4 PHASING AND IDENTIFICATION:

The contractor shall verify the existing phasing on all equipment being reconnected to a new service prior to removing the equipment and shall reconnect the equipment back to match original phasing following the completion of the installation of the new service.

End of Appendix Section 16122

Section 16310 - PRIMARY SWITCH STATION

PART 1 GENERAL

1.01 Description of Work

- A. The pad-mounted gear shall be in accordance with the one-line diagram, and shall conform to the following specification. This gear shall be type PME-11 or PME-9 as determined by consultation with the University of Arizona Electrical Engineer. It shall be as manufactured by S&C Corporation or prior approved equal.
- B. The pad-mounted gear shall consist of a single self-supporting dead front enclosure, containing interrupter switches and power fuses with the necessary accessory components, all completely factory-assembled and operationally checked.

1.02 Ratings

- A. The ratings for the integrated pad-mounted gear shall be as designated below:

KV, Nominal 14.4	
KV, Maximum Design	17.0
KV, BIL	95
Main Bus Continuous, Amperes	600
Three Pole Interrupter Switches	
Continuous, Amperes (Source/Feeder)	600/600
Live Switching, Amperes (Source/Feeder)	600/600
Two-Time Duty-Cycle Fault-Closing Capability, Amperes Rms Asymmetrical	22,400
Fuses with Integral Load Interrupter	
Maximum, Amperes	200
Live Switching, Amperes	200
Two-Timing Duty-Cycle Fault-Closing Capability, Amperes Rms Asymmetrical	22,000
Short-Circuit Ratings	
Amperes, Rms Symmetrical at Mva Three-Phase Symmetrical at Rated Nominal Voltage	22,000
	310

- B. The momentary and two time duty cycle fault closing ratings of switches and bus, interrupting ratings of fuses, and one-time duty-cycle fault-closing capabilities of the fuses with integral load interrupters shall equal or exceed the short-circuit ratings of the pad-mounted gear.

1.03 Certification of Ratings

- A. The manufacturer shall be completely and solely responsible for the performance of the basic switch and fuse components as well as the complete integrated pad-mounted gear assembly as rated.
- B. The manufacturer shall furnish with the bid certification of ratings of the basic switch and fuse components and the integrated pad-mounted gear assembly consisting of the switch and fuse components in combination with the enclosure.

1.04 Compliance with Standard and Codes

- A. The pad-mounted gear shall conform to or exceed the applicable requirements of the following standards and codes:
 - 1. Applicable safety and health standards promulgated pursuant to Federal Occupational Safety and Health Act of 1970 which are in effect 30 days prior to the date of quotation or bid.
 - 2. Article 490-21(B)(2) Circuit Interrupting Devices (Load Interrupters) in the National Electrical Code, which specifies that the interrupter switches in combination with power fuses shall safely withstand the effects of closing, carrying, and interrupting all possible currents up to the assigned maximum short-circuit rating.
 - 3. All portions of ANSI, IEEE, and NEMA standards applicable to the basic switch and fuse components.

1.05 Enclosure Design

- A. To ensure a completely coordinated design, the pad-mounted gear assembly shall be constructed in accordance with the minimum construction specifications of the fuse and/or switch manufacturer to provide adequate electrical clearances and adequate space for fuse handling.
- B. In establishing the requirements for the enclosure design, consideration shall be given to all relevant factors such as controlled access and tamper resistance. Provide padlock and penta head fasteners, in addition to manufacturer's normal controls.

PART II PRODUCTS AND EXECUTION

2.01 Insulators

- A. The interrupter-switch and fuse-mounting insulators shall be of a cycloaliphatic epoxy resin system with characteristics and restrictions as follows:
 - 1. Operating experience of at least 10 years under similar conditions.
 - 2. Ablative action to ensure nontracking properties.
 - 3. Adequate leakage distance established by test per IEC.
 - 4. Adequate strength for short-circuit stress established by test.
 - 5. Conformance with applicable ANSI standards.
 - 6. Homogeneity of the cycloaliphatic epoxy resin throughout each insulator to provide maximum resistance to power arcs. Ablation due to high temperatures from power arcs shall continuously expose more material of the same composition and properties so that no change in mechanical or electrical characteristics takes place because of arc-induced ablation. Furthermore, any surface damage to insulators during installation or maintenance of the pad-mounted gear shall expose material of the same composition and properties so that insulators with minor surface damage need not be replaced.

2.02 High-Voltage Bus

- A. Bus and interconnections shall consist of copper bar.
- B. Bus and interconnections shall withstand the stresses associated with short circuits up through the maximum rating of the pad-mounted gear, including proper allowance for transient conditions.
- C. All current carrying parts shall be copper or bronze.

2.03 Ground-Connection Pads

- A. A ground-connection pad shall be provided in each compartment of the padmounted gear.

- B. The ground-connection pad shall be constructed of steel, 3/8" thick for use with 600 ampere main bus which shall be copper clad and welded to the enclosure, and shall have a short-circuit rating equal to that of the integrated assembly.
- C. Ground-connection pads shall be coated with a uniform coating of an oxide inhibitor and sealant prior to shipment.

2.04 Enclosure

- A. The pad-mounted gear enclosure shall be of unitized monocoque (not structural frame-and-bolted-sheet) construction to maximum strength, minimize weight, and inhibit internal corrosion.
- B. The basic material shall be 11-gauge hot-rolled, pickled, and oiled steel sheet.
- C. All structural joints and butt joints shall be welded, and the external seams shall be ground flush and smooth.
 - 1. The gas-shielded short-circuiting transfer welding process shall be employed to eliminate alkaline residues and to minimize distortion and spatter.
 - 2. Any welds made by other than this method shall be ground and sanded (wire brushed if internal) to remove all scale and alkaline residues formed during welding.
- D. To guard against unauthorized or inadvertent entry, enclosure construction shall not utilize any externally accessible hardware.
- E. The base shall consist of continuous 90-degree flanges, turned inward and welded at the corners, for bolting to the concrete pad. The flanges shall be formed from double-thickness folded edges for strength and rigidity, with the sheared edges folded back into the inside of the enclosure to minimize exposure to corrosive attack.
- F. The door openings shall have 90-degree flanges, facing outward, that shall provide strength and rigidity as well as deep overlapping between doors and door openings to guard against water entry.
- G. Roof edges shall be formed to create a mechanical maze with the top flanges of the enclosure which shall allow free-flow ventilation to help keep the enclosure interior dry while discouraging tampering or insertion of foreign objects.
- H. A heavy coat of insulating "no-drip" compound shall be applied to the inside surface of the roof to prevent condensation of moisture thereon.
- I. Insulating interphase and end barriers of fiberglass-reinforced polyester shall be provided for each interrupter switch and each set of power fuses where required to achieve BIL ratings. Additional insulating barriers of the same material shall separate the front compartments from the rear compartments and isolate the tie bus (where furnished).
- J. Models containing source switches rated 600 amperes continuous shall have full-length steel barriers separating adjoining compartments.
- K. Lifting tabs shall be removable. Sockets for the lifting tab bolts shall be blind-tapped. A resilient material shall be placed between the lifting tabs and the enclosure to prevent the tabs from scratching the enclosure finish. To help retard corrosion, this material shall be closed-cell neoprene to prevent moisture from being absorbed and held between the tabs and the enclosure.
- L. Interrupter switches shall be provided with dual-purpose front barriers. These barriers, in their normal hanging positions, shall guard against inadvertent contact with live parts. It shall also be possible to lift these barriers out and insert them into the open gap when the switch is open. A window panel shall be provided to allow viewing of the switch position without removing the

barriers. These barriers shall meet the requirements of the National Electrical Safety Code

- M. Each fuse shall be provided with a dual-purpose front barrier. These barriers, in their normal hanging positions, shall guard against inadvertent contact with live parts. It shall also be possible to lift these barriers out and insert them into the open gaps when the fuses are in the disconnect position. These barriers shall meet the requirements of the National Electrical Safety Code
- N. A (steel-compartmented) base spacer shall be provided to increase the elevation of live parts in the pad-mounted gear above the mounting pad by 24 inches.

2.05 Doors

- A. Doors shall be constructed of 11 gauge hot-rolled, pickled, and oiled steel sheet.
- B. Door-edge flanges shall overlap with door-opening flanges and shall be formed to create a mechanical maze that shall guard against water entry and discourage tampering or insertion of foreign objects, but shall allow free-flow ventilation to help keep the enclosure interior dry.
- C. Doors shall have a minimum of three stainless steel hinges and hinge pins. The hinge pins shall be welded in place to guard against tampering.
- D. In consideration of controlled access and tamper resistance, each door (or set of double doors) shall be equipped with a positive-action three-point latching system.
- E. Each door (or set of double doors) shall be provided with a recessed stainless steel door handle. The door handle shall be padlockable and shall incorporate a hood to protect the padlock shackle from tampering. The handle shall be provided with a recessed penta head bolt for additional security.
- F. Doors providing access to solid-material expulsion-type power fuses shall have provisions to store spare refill units.
- G. Each door shall be provided with a galvanized-steel door holder located above the door opening. These holders shall be hidden from view when the door is closed, and it shall not be possible for the holders to swing inside the enclosure.
- H. Doors shall automatically self lock open.

2.06 Ventilation System

- A. Ventilation system shall be provided along the bottom and top at each side of the enclosure.
- B. Each vent shall have an inside baffle to protect against insertion of foreign objects, or shall be so constructed as to prevent insertion of foreign objects.

2.07 Finish

- A. During fabrication, the areas of structural parts which may later become inaccessible, such as folded edges and overlapping members, shall be given a phosphatizing bath and an iron-oxide zinc-chromate anti-corrosion primer to ensure that all surfaces are protected.
- B. Any welds made by other than the gas-shielded short-circuiting transfer welding process shall be ground and sanded (wire brushed if internal) to remove all scale and alkaline residues formed during welding.
- C. Full coverage at joints and blind areas shall be achieved by processing enclosures independently of components such as doors and roofs before assembly into the utilized structures.

- D. All exterior seams shall be filled and sanded smooth for neat appearance.
- E. To remove oils and dirt, and to form a chemically and anodically neutral conversion coating to improve the finish-to-metal bond, and to retard underfilm propagation of corrosion, all surfaces shall undergo a thorough pretreatment process before any protective coatings are applied.
- F. After pretreatment, protective coatings shall be applied that shall help resist corrosion and protect the steel enclosure. To establish the ability of the finishing system to resist corrosion and protect the enclosure, representative test specimens shall satisfactorily pass the following tests:
 - 1. 1000 hours of exposure to salt-spray testing per ASTM B 11 7-73 with loss of adhesion from bare metal not to extend more than 1/8" and underfilm corrosion not to extend more than 1/32" from the scribe.
 - 2. 1000 hours of humidity testing per ASTM D 2247 with the formation of no more than #6 medium blisters as evaluated per ASTM D 714-56.
 - 3. 500 hours of accelerated weather testing per ASTM G 53-77 with no more than 25% reduction of paint gloss.
 - 4. Crosshatch adhesion testing per ASTM D 3359 Method B with no loss of paint.
 - 5. 160 inch-pound impact adhesion testing per ASTM D 2794-69 with no paint chipping or cracking.
 - 6. Certified test abstracts substantiating such capabilities shall be furnished with the bid.
- G. The finishing system shall be applied without sags or runs for a pleasing appearance.
- H. After the finishing system has been properly applied and cured, welds along the enclosure bottom flange and around the door hinges shall be coated with a wax-based anti-corrosion moisture barrier to give these areas added corrosion resistance. Weld studs within the enclosure that are not covered by nuts shall be coated with an oxide-inhibiting compound to help guard against corrosion starting on the exposed threads.
- I. After the enclosure is completely assembled and the components (switches, fuses, bus, etc.) are installed, the finish shall be inspected for scuffs and scratches. Blemishes shall be carefully touched up by hand to restore the protective integrity of the finish.
- J. The finish shall be sage green. Contractor shall sand finish with #220 grit dual action Sander Prime with duPont Vari Prime #815/8165 and apply 3 wet coats of duPont catalyzed acrylic enamel. Color is Federal Standard 595b, 14449.

2.08 Corrosion

- A. To guard against corrosion, all hardware (including door fittings, fasteners, etc.), all operating-mechanism parts, and other parts subject to abrasive action from mechanical motion shall be of either non-ferrous materials, or galvanized, or zinc-plated ferrous materials. Cadmium-plated ferrous parts shall not be used.

2.09 Tamper Resistance

- A. In consideration of tamper resistance, the enclosure shall withstand a prying leverage of 75 foot-pounds applied to all joints, crevices, hinges, seams and locking means. All such openings shall prevent insertion of number 10 AWG hard-drawn copper wire after the prying leverage has been applied.

2.10 Interrupter Switches

- A. Interrupter switches shall have a two-time duty-cycle fault-closing rating equal to or exceeding the short-circuit rating ability to close the interrupter switch twice against a three-phase fault with

asymmetrical current in at least one phase equal to the rated value, with the switch remaining operable and able to carry and interrupt rated current. Tests substantiating these ratings shall be furnished with the bid.

- B. Interrupter switches shall be operated by means of an externally accessible 3/4 inch hex switch-operating hub. The switch-operating hub shall be located within a recessed pocket mounted on the side of the pad-mounted gear enclosure and shall accommodate a 3/4 inch deep-socket wrench or a 3/4 inch shallow-socket wrench with extension. The switch-operating hub pocket shall include a pad lockable access cover that shall incorporate a hood to protect the padlock shackle from tampering. Stops shall be provided on the switch operating hub to prevent over travel and thereby guard against damage to the interrupter switch quick-make, quick-break mechanism.
- C. Interrupter switches shall utilize a quick-made, quick-break mechanism installed by the switch manufacturer. The quick-make, quick-break mechanism shall be integrally mounted on the switch frame, and shall swiftly and positively open and close the interrupter switch independent of the switch independent of the switch-operating hub speed. Switches shall be the air break type.
- D. Each interrupter switch shall be completely assembled and adjusted by the switch manufacturer on a single rigid mounting frame. The frame shall be of welded steel construction such that the frame intercepts the leakage path which parallels the open gap of the circuit when the interrupter switch is in the open position.
- E. Interrupter switch contacts shall be of silver-to-silver construction for optimum current transfer, and shall be backed up by stainless steel springs to provide constant high contact pressure.
- F. Interrupter switches shall be provided with a single blade per phase for circuit closing including fault closing, continuous current carrying, and circuit interrupting. Spring-loaded auxiliary blades shall not be permitted. Interrupter switch blade supports shall be permanently molded in place in a unified insulated shaft constructed of the same cycloaliphatic epoxy resin as the insulators.
- G. Circuit interruption shall be accomplished by use of an interrupter which is positively and inherently sequenced with the blade position. It shall not be possible for the blade and interrupter to get out of sequence. Circuit interruption shall take place completely within the interrupter, with no external arc or flame. Any exhaust shall be vented in a controlled manner through a deionizing vent.
- H. Interrupter switches shall have a readily visible open gap when in the open position to allow positive verification of correct switch position.
- I. Each interrupter switch shall be provided with a folding switch-operating handle. The switch-operating handle shall be secured to the inside of the switch-operating hub pocket by a brass chain. The folded handle shall be stored behind the closed switch-operating-hub access door.
- J. Key interlocks shall be provided between each fuse-compartment door and all switches to guard against opening fuse-compartment door(s) unless all switches are locked open.
- K. Grounding studs shall be provided at all switch terminals. Grounding studs shall also be provided on the ground pad in each interrupter switch compartment and on terminals and ground pads in any cable-termination compartment. The momentary rating of the grounding studs shall equal or exceed the short-circuit ratings of the pad-mounting gear.
- L. Mounting provisions shall be provided to accommodate one three-phase fault indicator with three single-phase sensors in each switch compartment on units with more than one switch position.

2.11 Fuses

- A. Fuses shall be disconnect style, solid-material power fuses, and shall utilize refill-unit-and-holder

construction. The refill unit or fuse unit shall be readily replaceable and low in cost.

1. Fusible elements shall be non-aging and non-damageable so that it is unnecessary to replace unblown companion fuses on suspicion of damage following a fuse operation.
 2. Fusible elements for refill units, rated 10 amperes or larger, shall be helically coiled to avoid mechanical damage due to stresses from surges.
 3. Fusible elements shall be supported in air to allow cooling after current surges to help prevent damage.
 4. Each refill unit shall have a single fusible element to eliminate the possibility of unequal current sharing in parallel current paths.
 5. Power fuses shall have melting time-current characteristics that are permanently accurate to within a total of 10% in terms of current. Time current characteristics shall be available which permit coordination with protective relays, automatic circuit reclosers, and other fuses.
 6. Power fuses shall be capable of detecting and interrupting all faults whether large, medium, or small (down to minimum melting current), under all realistic conditions of circuitry, with line-to-line or line-to-ground voltage across the power fuse, and shall be capable of handling the full range of transient recovery voltage severity associated with these faults.
 7. All arcing accompanying power fuse operation shall be contained within the fuse, and all arc products and gases evolved during fuse operation shall be vented through an exhaust control device that shall effectively control fuse exhaust.
 8. Power fuses shall be equipped with a blown-fuse indicator that shall provide visible evidence of fuse operation while installed in the fuse mounting.
 9. Fuses shall be S&C type SML-4Z units which accept type SM-4 refill units.
- B. Fuse-mounting jaw contacts shall incorporate an integral load interrupter that shall permit live switching of fuses with a hook stick.
1. The integral load interrupter housing shall be of the same cycloaliphatic epoxy resin as the insulators.
 2. The integral load interrupter shall be in the current path continuously. Auxiliary blades or linkages shall not be used.
 3. Live switching shall be accomplished by a firm, steady opening pull on the fuse pull ring with a hook stick. No separate load-interrupting tool shall be required.
 4. The integral load interrupter shall require a hard pull to unlatch the fuse to reduce the possibility of an incomplete opening operation.
 5. Internal moving contacts of the integral load interrupter shall be self-resetting after each opening operation to permit any subsequent closing operation to be performed immediately.
 6. Circuit interruption shall take place completely within the integral load interrupter with no external arc or flame.
 7. The integral load interrupter and the fuse shall be provided with separate fault-closing contacts and current-carrying contacts. The fuse hinge shall be self-guiding and, together with the fault-closing contacts, shall guide the fuse into the current-carrying contacts during closing operations. Circuit-closing inrush currents and fault currents shall be picked up by the fault-closing contacts, not by the current-carrying contacts or interrupting contacts.
8. Integral load interrupters for power fuses shall have a one-time duty-cycle fault-closing capability equal to the interrupting rating of the fuse, and a two-time duty-cycle fault-closing capability of 13,000 amperes RMS asymmetrical at 14.4 KV or 25 KV. The duty-cycle fault-closing capability defines the level of available fault current into which the fuse can be closed the specified number of times (once or twice), without a quick-make mechanism and when operated vigorously through its full travel without hesitation at any point, with the integral load interrupter remaining operable and able to carry and interrupt remaining operable and able to carry and interrupt currents up to the emergency peak-load capabilities of the fuse.
- C. Fuse terminal pads shall be provided with a two-position adapter. This adapter shall accommodate a variety of cable-terminating devices.

- D. Grounding studs shall be provided at all fuse terminals. One grounding stud shall also be provided on the ground pad in each fuse compartment. The momentary rating of the grounding study shall equal or exceed the short-circuit ratings of the pad-mounted gear.
- E. A full set of fuses, plus a full set of spare fuse refills, shall be provided for each fuse position as shown on the one line diagram.

2.12 Warning Signs

- A. All external doors shall be provided with permanent "Caution - High Voltage -Keep out" signs.
- B. The inside of each door shall be provided with "Danger - High Voltage -Qualified Persons Only" signs (Bilingual English, Spanish and Japanese).
- C. The inside each door providing access to interrupter switches shall be provided with warning signs indicating that "Switch Blades May Be Energized In Any Position".
- D. The inside of each door providing access to power fuses shall be provided with permanent warning signs indicating that "Fuses May Be Energized in Any Position".
- E. All warning signs shall be provided in both English and Spanish.

2.13 Rating Nameplates and Connection Diagrams

- A. The outside of each door (or set of double doors) shall be provided with nameplates indicating the manufacturer's name, catalog number, and model number.
- B. The inside of each door (or set of double doors) shall be provided with nameplates indicating the following: voltage ratings (kv, nominal; kv, maximum design; and kv, BIL); main bus continuous rating (amperes); short-circuit ratings (amperes, RMS symmetrical and Mva three-phase symmetrical at rated nominal voltage); the type of fuse and its ratings (amperes, one-time/two-time duty-cycle fault-closing capability); and interrupter switch ratings (amperes, continuous; amperes, live switching - load splitting and load dropping; amperes, fault-closing, duty-cycle, two-time RMS symmetrical, RMS asymmetrical, and one-second symmetrical).
- C. A three-line connection diagram showing interrupter switches, fuses with integral load interrupter, and bus along with the manufacturer's model number shall be provided on the inside of the front and rear doors (or set of double doors), and on the inside of each switch-operating-hub access cover.

2.14 Auxiliaries

- A. Holders, and refill units for original installation, as well as one spare fuse unit or refill unit for each fuse mounting shall be furnished.
- B. A fuse handling tool as recommended by the fuse manufacturer shall be furnished.
- C. One bolted connector per phase accommodating NO.2 solid through 500 MCM stranded copper or aluminum conductor shall be furnished for all switch and fuse positions.

2.15 Three-Phase Fault Indicator

- A. A three-phase fault indicator shall be provided and installed with three single phase sensors in each switch compartment on all units.
- B. Fault indicators shall be provided at switching points on distribution circuits and unfused taps. A

fault indicator shall be provided for each phase. Trip setting shall be as required for the given circuit. Reset shall be automatic and initiated by normal current. Fault indicators shall be type CR (10) manufactured by RTE Corporation, Waukesha, Wisconsin, or approved equal.

PART 3 INSTALLATION

3.00 Installation

- A. The switch assembly shall be mounted securely on a concrete pad minimum of six inches in thickness, designed adequately for the weight of the switch. The pad shall extend a minimum of 3' from the front of each set of doors. The switch shall be securely anchored to the pad per the manufacturer's recommendations. A ground loop shall circle the switch and provisions for grounding the switch and landing any grounds or shields shall be provided for within the enclosure. During installation all internal shields shall be left inside of the switch and shall not be left out of the cabinet or subject to exposure to the elements. Any shield which has been damaged due to neglect or exposure to the elements shall be replaced to the satisfaction of the University of Arizona Electrical Engineer.

End of Appendix Section 16310

Section 16311 Underground Distribution Switchgear 15 kV Class

Note: Maintenance personnel shall seek Engineering assistance in applying this specification to the procurement and installation of this equipment.

Note: Consultants shall review this specification and revise it in accordance with good engineering practice and scope of the application.

Part: 1 GENERAL

- 1.1 The switchgear shall be in accordance with the single-line diagram, and shall conform to the following specification.
- 1.2 The switchgear shall consist of a gas-tight tank containing SF6 gas, load-interrupter switches and resettable fault interrupters with visible open gaps and integral visible grounds, and a microprocessor-based overcurrent control. Load-interrupter switch terminals shall be equipped with bushings rated 600 amperes continuous, and fault-interrupter terminals shall be equipped with bushing wells rated 200 amperes continuous or bushings rated 600 amperes continuous (as specified) to provide for elbow connection. Manual operating mechanisms and viewing windows shall be located on the opposite side of the tank from the bushings and bushing wells, so that operating personnel shall not be required to perform any routine operations in close proximity to high-voltage elbows and cables.

1.3 Ratings

The ANSI ratings for the integrated switchgear shall be as designated below.

Frequency, Hz	60
Short-Circuit Current	
Amperes, RMS, Symmetrical	25 KA
Voltage Class, kV	15.5
Maximum Voltage, kV	15.5
BIL Voltage, kV	95
Main Bus Continuous Current, Amperes	600
Three-Pole Load-Interrupter Switches	
Continuous Current, Amperes	600
Load Dropping Current, Amperes	600
Fault Closing Current, Duty-Cycle	
Three-Time, Amperes, RMS, Symmetrical	25,000
Three-Time, Amperes, Peak	65,000
Ten-Time, Amperes, RMS, Symmetrical	16,000
Ten-Time, Amperes, Peak	41,600
Fault Interrupters	
Continuous Current, Amperes	600
Load Dropping Current, Amperes	600
Fault Interrupting Current, Duty-Cycle	
Three-Time, Amperes, RMS Symmetrical	25,000
Ten-Time, Amperes, RMS, Symmetrical	25,000
Fault Closing Current, Duty-Cycle	
Three-Time, Amperes, RMS, Symmetrical	25,000
Three-Time, Amperes, Peak	65,000
Ten-Time, Amperes, RMS, Symmetrical	16,000
Ten-Time, Amperes, Peak	41,600

Note: Ratings with respect to this gear is based on the fault current available to the system as of October 1, 2009. Fault current analysis shall be necessary to verify these rating and/or increase them.

1.4 Certification of Ratings

- The manufacturer of the switchgear shall be completely and solely responsible for the performance of the load-interrupter switch and fault interrupter as well as the complete integrated assembly as rated.
- The manufacturer shall furnish, upon request, certification of ratings of the load-interrupted, and the integrated switchgear assemble consisting of switches an default interrupters in combination with the gas-tight tank.

1.5 Compliance with Standards and Codes

The switch gear shall conform to or exceed the applicable requirements of the following standards and codes:

- The applicable portions of ANSI C57.12.28 covering enclosure integrity for pad-mounted equipment.
- The applicable portions of ANSI C37.71, ANSI C37.72, ANSI C37.73, IEC 56 and IEC 265-1 (Class A), which specify test procedures and sequences for the load-interrupters switches, fault interrupters, and the complete switchgear assembly.

2.0 CONSTRUCTION

2.1 SF6- Gas Insulation

- The SR6 gas shall conform to ASTM D2472.
- The switchgear shall be filled with SF6 gas to pressure of 7 psig at 68° F.
- The gas-tight tank shall be evacuated prior to filling with SF6 gas to minimize moisture in the tank.
- The switchgear shall withstand system voltage at a gas pressure of 0 psig at 68° F.
- A gas-fill valve shall be provided.
- A temperature-compensated pressure gauge shall be provided that is color coded to show the operating range. The gauge shall be mounted inside the gas-tight tank (visible through a large viewing window) to provide consistent pressure readings regardless of the temperature or altitude at the installation site.

2.2 Gas-Tight Tank

- The tank shall be submersible and able to withstand up to 10 feet of water over the base.
- The tank shall be of welded construction and shall be made of 7-gauge mild steel or Type 304L stainless, as specified in Section 4.0.
- A means of lifting the tank shall be provided.

2.3 Gas-tight Tank Finish (for mild steel only)

- To remove oils and dirt, to form a chemical and anodically neutral conversion coating to improve the finish-to-metal bond, and to retard underfilm propagation of corrosion, mild-steel surfaces shall undergo a thorough pretreatment process comprised of a fully automated system of cleaning, rinsing, phosphatizing, sealing drying, and cooling, before any protective coatings are applied. By utilizing an automated pretreatment process, the mild-steel surfaces

- of the gas-tight tank shall receive a highly consistent thorough treatment, eliminating fluctuations in reaction time, reaction temperature, and chemical concentrations.
- After pretreatment, protective coatings shall be applied that shall help resist corrosion and protect the mild-steel surfaces of the gas-tight tank. To establish the capability to resist corrosion and protect the mild steel, representative test specimens coated by the manufacturer's finishing system shall satisfactorily pass the following tests:
 - 1500 hours of exposure to salt-spray testing per ASTM B 117 with:
 - Underfilm corrosion not to extend more than 1/32 in. from the scribe, as evaluated per ASTM D 1645, Procedure A, Method 2 (scraping);and
 - Loss of adhesion from bare metal not to extend more than 1/8 in. from the scribe.
 - 1000 hours of humidity testing per ASTM D 4585 using the Cleveland Condensing Type Humidity Cabinet, with no blistering as evaluated per ASTM D 714.
 - Crosshatch-adhesion testing per ASTM D 3359 Method B, with no loss of finish. Certified test abstracts substantiating the above capabilities shall be furnished upon request.
 - The finish shall be inspected for scuffs and scratches. Blemishes shall be touched up by hand to restore the protective integrity of the finish.
 - The finish shall be indoor light gray, satisfying the requirements of ANSI Standard Z55.1 for No. 61.

2.4 Viewing Windows

- Each load-interrupter switch shall be provided with a large viewing window at least 6 inches to allow visual verification of the switch-blade position (closed, open, and grounded) while shining a flashlight on the blades.
- Each fault interrupter shall be provided with a large viewing window at least 6 inches by 12 inches to allow visual verification of the disconnect-blade position (closed, open and grounded) while shining a flashlight on the blades.
- Viewing windows shall be located on the opposite side of the gear from the bushings and bushing wells so that operating personnel shall not be required to perform any routine operations in close proximity to high-voltage elbows and cables.
- A cover shall be provided for each viewing window to prevent operating personnel from viewing the flash which may occur during switching operations.

2.5 High-Voltage Bus

- Bus and interconnections shall withstand the stresses associated with short-circuit currents up through the maximum rating of the switchgear.
- Before installation of aluminum bus, all electrical contact surfaces shall first be pre-pped by machine-abrading to remove any oxide film. Immediately after this operation, the electrical contact surfaces shall be coated with a uniform coating of an oxide inhibitor and sealant.

2.6 Provisions for Grounding

- One ground-connection pad shall be provided on the gas-tight tank of the switchgear.
- The ground-connection pad shall be constructed of stainless steel and welded to the gas-tight tank, and shall have a short-circuit rating equal to that of the switchgear.
- When an enclosure is provided, no less than one enclosure ground pad shall be provided. The following optional feature should be specified as required:
- One ground-connection pad per way shall be provided.

2.7 Connections

- For gear rated 12.5kA short circuit, load-interrupter switches shall be equipped with 600-ampere bushings, and fault interrupters shall be equipped with 200-ampere bushing wells.
- For gear rated 25kA short circuit, load-interrupter switches and fault interrupters shall be equipped with 600-or 900-ampere bushings.
- Bushings and bushing wells shall be located on one side of the gear to reduce the required operating clearance. The following optional feature should be specified as required:
- Fault interrupters shall be equipped with 600-ampere bushings.
- Load interrupter switches shall be equipped with 200-ampere bushing wells.

2.8 Bushings and Bushing Wells

- Bushings and bushing wells shall conform to ANSI/IEEE Standard 386
- Bushings and bushing wells shall include a semiconductive coating.
- Bushings and bushing wells shall be mounted in such a way that the semiconductive coating is solidly grounded to the gastight tank.

3.0 BASIC COMPONENTS

- Load-Interrupter Switches
 - The three-phase, group-operated load-interrupter switches shall have a three-time and ten-time duty-cycle fault-closing rating as specified under "Ratings." This rating defines the ability to close the switch the designated number of times against a three-phase fault with asymmetrical (peak) current in at least one phase equal to the rated value, with the switch remaining operable and able to carry and interrupt rated current. Certified test abstracts establishing such ratings shall be furnished up request.
 - The switch shall be provided with an integral ground position that is readily visible through the viewing window to eliminate the need for cable handling and exposure to high voltage to ground the equipment.
 - The ground position shall have a three-time and ten-time duty-cycle fault-closing rating.
 - The switch shall be provided with an open position that is readily visible through the viewing window to eliminate the need for cable handling and exposure to high voltage to establish a visible gap.
 - The open gaps of the switch shall be sized to allow cable testing through a feedthru bushing or the back of the elbow.
- Fault Interrupters
 - Fault interrupters shall have a three-time and ten-time duty-cycle fault-closing and fault interrupting rating as specified under "Ratings." This rating defines the fault interrupter's ability to close the designated number of times against a three-phase fault with asymmetrical (peak) current in at least one phase equal to the rated value and clear the resulting fault current, with the interrupter remaining operable and able to carry and interrupt rated current. Certified test abstracts establishing such ratings shall be furnished upon request.
 - The fault interrupter shall be provided with a disconnect with an integral ground position that is readily visible through the viewing window to eliminate the need for cable handling and exposure to high voltage to ground equipment.
 - The ground position shall have a three-time and ten-time duty-cycle fault-closing rating.
 - The disconnect shall be provided with an open position that is readily visible through the viewing window, eliminating the need for cable handling and exposure to high voltage to establish a visible gap.
 - The fault interrupter, including its three-position disconnect, shall be a single integrated design so that operation between the closed and open positions or the open and grounded positions is accomplished with a single, intuitive movement.

- The open gaps of the disconnect shall be sized to allow cable testing through a feedthru bushing or the back of the elbow.
- An internal indicator shall be provided for each fault interrupter to show when it is in the tripped condition. The indicator shall be clearly visible through the viewing window.
- Operating Mechanisms
 - Load-interrupter switches and fault interrupters shall be operated by means of a quick-make, quick-break mechanism.
 - The manual handle shall charge the operating mechanism for closing, opening, and grounding of the switches and fault interrupters.
 - A single, integrated operating mechanism shall fully operate each fault interrupter or load interrupter switch in a continuous movement, so that additional operations are not required to establish open or grounded positions.
 - Operating mechanisms shall be equipped with an operation selector to prevent inadvertent operation from the closed position directly to the grounded position, or from the grounded position directly to the closed position. The operation selector shall require directly to the grounded position, or from the grounded position directly to the closed position. The operation selector shall require physical movement to the proper position to permit the next operation.
 - Operating shafts shall be padlockable in any position to prevent operation.
 - The operation selector shall be padlockable to prevent operation to the grounded position.
 - The operating mechanism shall indicate switch position which shall be clearly visible from the normal operating position.
- Overcurrent Control
 - A microprocessor-based overcurrent control shall be provided to initiate fault interruption.
 - For dry-vault-mounted style and pad-mounted style switchgear, the control shall be mounted in a watertight enclosure, for UnderCover style and wet-vault-mounted style switchgear, the control shall be mounted in a submersible enclosure. The control shall be removable in the field without taking the gear out to service.
 - Control settings shall be field programmable using a personal computer connected via a data port to the control. The data port shall be accessible from the exterior of the enclosure. Neither external power nor energization of the gear shall be required to set or alter control settings.
 - Power and sensing for the control shall be supplied by integral current transformers.
 - The minimum total clearing time (from initiation of the fault to total clearing) for fault interruption shall be 40 milliseconds (2.4 cycles) at 60 hertz or 44 milliseconds (2.2 cycles) at 50 hertz.
 - The control shall feature time-current characteristic (TCC) curves including standard E speed, K-speed, coordinating-speed tap, coordinating-speed main, and relay curves per IEEE C37.112-1996. Coordinating-speed tap curves shall optimize coordination with load-side weak-link/backup current-limiting fuse combinations, and coordinating-speed main curves shall optimize coordination with tap-interrupter curves and upstream feeder breakers.
 - The standard E-speed curve shall have phase-overcurrent settings ranging from 25E through 400E. The standard K-speed curve shall have phase-overcurrent settings ranging from 25k through 200K. The coordinating-speed tap curve shall have phase-overcurrent and independent ground-overcurrent settings ranging from 50 amperes through 400 amperes. The coordinating-speed main curve shall have phase-overcurrent settings ranging from 100 amperes through 800 amperes and independent ground-overcurrent settings ranging from 100 amperes through 400 amperes.
 - Time-current characteristic curves shall conform to the following IEEE C37, 112-1996 IEEE Standard Inverse-Time Characteristic equations for Overcurrent Relays: U.S. Moderately Inverse Curve U1, U.S. Inverse Curve U2, U.S. Very Inverse Curve U3, U.S. Extremely

- Inverse Curve U4, U.S. Short-Time Inverse Curve U5, I.E.C. Class A Curve (Standard Inverse) C1, I.E.C. Class B Curve (Very Inverse) C2, I.E.C. Class C Curve (Extremely Inverse) C3, I.E.C. Long-time Inverse Curve C4, and I.E.C. Short-Time Inverse Curve C5.
- The control shall have field-adjustable instantaneous-trip setting (0.2 kA through 2 kA) and definite-time delay settings (32 ms through 96ms for coordinating-speed tap and 64ms through 128 ms for coordinating-speed main), to allow tailoring of the coordinating-speed tap and coordinating speed main curves to the application.
 - Event records shall be easily extractable from the control using a personal computer connected to the data port.
 - Optional Voltage Indication (Specify one of the following as required.)
 - Voltage Indication.
 - Voltage indication shall be provided for each load-interrupter switch and fault interrupter by means of capacitive taps on the bushings, eliminating the need for cable handling and exposure to high voltage to test the cables for voltage prior to grounding. This feature shall include a flashing liquid-crystal display to indicate the presence of voltage for each phase, and a solar panel to supply power for testing of the complete voltage-indication circuit.
 - The voltage-indication feature shall be mounted on the covers for the viewing windows, on the opposite side of the gear from the bushings and bushing wells, so that operating personnel shall not be required to perform any routine operations in close proximity to high-voltage elbows and cables.
 - Voltage indication with provisions for low-voltage phasing.
 - Voltage indication with provisions for low-voltage phasing shall be provided for each load-interrupter switch and fault interrupter by means of capacitive taps on the bushings, eliminating the need for cable handling and exposure to high voltage to test the cables for voltage and phasing. This feature shall include a flashing liquid-crystal display to indicate the presence of voltage for each phase, and a solar panel to supply power for testing of the complete voltage-indication circuit and phasing circuit.
 - The voltage-indication feature shall be mounted on the covers for the viewing windows, on the opposite side of the gear from the bushings and bushing wells, so that operating personnel shall not be required to perform any routine operations in close proximity to high-voltage elbows and cables.

4.0 Switchgear Style (Select UnderCover set-vault-mounted, dry-vault-mounted, or pad-mounted style)

- UnderCover Style
- The switchgear shall be suitable for subsurface installation.
- The switchgear shall be operable from grade level without exposure to high voltage.
- Operating personnel shall be able to verify the positions (closed, open, and grounded) of the load-interrupter switches and fault interrupters while standing.
- To guard against corrosion due to extremely harsh environmental conditions, the gas-tight tank shall be made of Type 304L stainless steel.
- The tank shall be designed for use in typical subsurface electrical manholes and vaults that are subject to occasional flooding to a maximum head of 10 ft. (3m) above the base of the tank. The water in these vaults may also contain typical levels of contaminants such as salt, fertilizer, motor oil, and cleaning solvents. Extreme environments such as tidal water, continuous submersion, abnormally high concentration of certain contaminants, or unusually high or low pH levels should be evaluated on a case-by-case basis.
- For gear rated 12.5 kA short circuit, the switchgear shall conform to or exceed the requirements of applicable portions of IEC 298, Appendix AA covering arc resistance, through 12.5 kA for 15 cycles.
- For gear rated 25 kA short circuit, the switchgear shall conform to or exceed the requirements of applicable portions of IEC 298, Appendix AA covering arc resistance, through 25 kA for 15 cycles.

4.2 Wet-Vault-Mounted Style

- The switchgear shall be suitable for installation in a vault.
- To guard against corrosion due to extremely harsh environmental conditions, the gas-tight tank shall be made of type 304L stainless steel.
- The tank shall be designed for use in typical subsurface electrical manholes and vaults that are subject to occasional flooding to a maximum head of 10 ft. (3m) above the base of the tank. The water in these vaults may also contain typical levels of contaminants such as salt, fertilizer, motor oil, and cleaning solvents. Extreme environments such as tidal waters, continuous submersion, abnormally high concentration of certain contaminants, or unusually high or low pH levels should be evaluated on a case-by-case basis.
- The following optional features should be specified as required:
- For gear rated 25kA short circuit, the switchgear shall conform to or exceed the requirements of applicable portions of IEC 298, Appendix AA covering arc resistance, through 25kA for 15 cycles.

4.3 Dry-Vault-Mounted-Style

- The switchgear shall be suitable for installation in a vault.
- The gas-tight tank shall be made of 7-gauge mild steel.
- The following optional features should be specified as required:
- To guard against corrosion due to extremely harsh environmental conditions, the gas-tight tank shall be made of type 304L stainless steel.
- For gear rated 12.5kA short circuit, the switchgear shall conform to or exceed the requirements of applicable portions of IEC 298, Appendix AA covering arc resistance, through 12.5 kA for 15 cycles.
- For gear rated 25 kA short circuit, the switchgear shall conform to or exceed the requirements of applicable portions of IEC 298, Appendix AA covering arc resistance, through 25 kA for 15 cycles.

4.4 Pad-Mounted Style

- The gas-tight tank shall be made of 7-gauge mild steel.
- The following optional feature should be specified as required:
- To guard against corrosion due to extremely harsh environmental conditions, the gas-tight tank shall be made of type 304L stainless steel.
- For gear rated 12.5kA short circuit, the switchgear shall conform to or exceed the requirements of applicable portions of IEC 298, Appendix AA covering arc resistance, through 12.5 kA for 15 cycles.
- For gear rated 25 kA short circuit, the switchgear shall conform to or exceed the requirements of applicable portions of IEC 298, Appendix AA covering arc resistance, through 25 kA for 15 cycles.
- Enclosure
- The switchgear shall be provided with a pad-mounted enclosure suitable for installation of the gear on a concrete pad.
- The pad-mounted enclosure shall be separable from the switchgear to allow clear access to the bushings and bushing wells for cable termination.
- The basic material shall be 14-gauge hot-rolled, pickled and oiled steel sheet.
- The enclosure shall be provided with removable front and back panels, and hinged lift-up roof sections for access to the operating and termination compartments. Each roof section shall have a retainer to hold it in the open position.
- Lift-up roof sections shall overlap the panels and shall have provisions for pad-locking that incorporate a means to protect the padlock shackle from tampering.

- The base shall consist of continuous 90-degree flanges, turned inward and welded at the corners, for bolting to the concrete pad.
- Panel openings shall have 90-degree flanges, facing outward, that shall provide strength and rigidity as well as deep overlapping between panels and pane openings to guard against water entry.
- For bushings rated 600 amperes continuous, the termination compartment shall be of an adequate depth to accommodate encapsulated surge arresters mounted on 600-ampere elbows having 200-ampere interfaces.
- For bushing wells rated 200-amperes continuous, the termination compartment shall be of an adequate depth to accommodate 200-ampere elbows mounted on feedthru inserts.
- An instruction manual holder shall be provided.
- Non-removable lifting tabs shall be provided.
- The following optional feature should be specified as required:
 - To guard against corrosion due to extremely harsh environmental conditions, the entire exterior of the enclosure shall be fabricated from Type 304 stainless steel.
- Enclosure finish.
- All exterior welded seams shall be filled and sanded smooth for neat appearance.
- To remove oils and dirt, to form a chemically and anodically neutral conversion coating to improve the finish-to-metal bond, and to retard underfilm propagation of corrosion, all surfaces shall undergo a thorough pretreatment process comprised of a fully automated system of cleaning, rinsing, phosphatizing, sealing, drying, and cooling, before any protective coatings are applied. By utilizing an automated pretreatment process, the enclosure shall receive a highly consistent thorough treatment, eliminating fluctuations in reaction time, reaction temperature, and chemical concentrations.
- After pretreatment, protective coatings shall be applied that shall help resist corrosion and protect the steel enclosure. To establish the capability to resist corrosion and protect the enclosure, representative test specimens coated by the manufacturer's finishing system shall satisfactorily pass the following tests:
 - 4,000 hours of exposure to salt-spray testing per ASTM B 117 with:
 - Underfilm corrosion not to extend more than 1/32 in. from the scribe, as evaluated per ASTM D 1645, Procedure A, Method 2 (scraping); and
 - Loss of adhesion from bare metal not to extend more than 1/8 in. from the scribe.
 - 1,000 hours of humidity testing per ASTM D 4585 using the Cleveland Condensing Type Humidity Cabinet, with no blistering as evaluated per ASTM D 714.
 - 500 hours of accelerated wreathing testing per ASTM G 53 using lamp UVB-313, with no chalking as evaluated per ASTM D 659, and no more than 10% reduction of gloss as evaluated per ASTM D 523.
 - Crosshatch-adhesion testing per ASTM D 3359 Method B, with no loss of finish.
 - 160-inch-pound impact, followed by adhesion testing per ASTM D 2794, with no chipping or cracking.
 - 3,000 cycles of abrasion testing per ASTM 4060, with no penetration to the substrate. Certified test abstracts substantiating the above capabilities shall be furnished upon request.
- The finish shall be inspected for scuffs and scratches. Blemishes shall be touched up by hand to restore the protective integrity of the finish.
- The finish shall be olive green, Munsell 7GY3.29/1.5.
- The following optional feature should be specified as required:
 - The finish shall be outdoor light gray, satisfying the requirements of ANSI Standard Z55.1 for No. 70.

5.0 LABELING

5.01 Hazard-Alerting Signs

- The exterior of the pad-mounted enclosure (if furnished) shall be provided with “Warning-Keep Out- Hazardous Voltage Inside- Can Shock, Burn, or Cause Death” signs
- Each unit of switchgear shall be provided with a “Danger-Hazardous Voltage- Failure to Follow These Instructions Will Likely Cause Shock, Burns, or Death” sign. The text shall further indicate that operating personnel must know and obey the employer’s work rules, know the hazards involved, and use proper protective equipment and tools to work on this equipment.
- Each unit of switchgear shall be provided with a “Danger-Keep Away- Hazardous Voltage-Will Shock, Burn, or Cause Death” sign.

5.02 Nameplates, Ratings Labels, and Connection Diagrams

- Nameplates, Ratings Labels, and Connection Diagrams
 - Each unit of switchgear shall be provided with a name plate indicating the manufacturer’s name, catalog number, model number, date of manufacture, and serial number.
 - Each unit of switch gear shall be provided with a ratings label indicating the following: voltage rating; main bus continuous current rating; short-circuit rating; fault-interrupter ratings including interrupting and duty-cycle fault-closing; and load-interrupter switch ratings including duty-cycle fault closing and short-time.

6.0 ACCESSORIES (Specify as required)

6.01 A USB cable kit shall be provided for connecting an overcurrent control to a user-furnished personal computer.

7.0 ANALYTICAL SERVICES

7.1 Short-Circuit Analysis

- The Design Engineer manufacturer shall provide a short-circuit analysis to determine the currents flowing in the electrical system under faulted conditions. Since expansion of an electrical system can result in increased available short-circuit current, the momentary and interrupting ratings of new and existing equipment on the system shall be checked to determine if the equipment can with stand the short-circuit energy. Fault contributions from utility sources, motors, and generators shall be taken into consideration. If applicable, results of the analysis shall be used to coordinate overcurrent protective devices and prepare an arc-flash hazard analysis of the system.
- Data used in the short-circuit analysis shall be presented in tabular format, and shall include the following information:
 - Equipment identifications
 - Equipment ratings
 - Protective devices
 - Operating voltages
 - Calculated short-circuit currents
 - X/R ratios
- A single-line diagram model of the system shall be prepared, and shall include the following information:
 - Identification of each bus
 - Voltage at each bus
 - Maximum available fault current, in kA symmetrical, on the utility source side of the incoming feeder or first upstream device.
 - Data for each transformer
 - Three-phase kVA rating

- Percent impedance
- Temperature rise, 65°C and 55/65°C
- Primary voltage
- Primary connection
- Secondary voltage
- Secondary connection
- X/R ratio
- Tap settings and available settings.
- The manufacturer shall use commercially available PC-based computer software such as Power System Analysis Frame work (PSAF-Fault) from CYME International, CYMDIST, and/or SKM Power Tools® for Windows with the PTW Dapper Module to calculate three-phase, phase-to-phase, and phase-to-ground fault currents at relevant locations in the electrical system, in accordance with ANSI Standards C37.010, C37.5, and C37.13. If applicable, an ANSI closing- and –latching duty analysis shall also be performed to calculate the maximum currents following fault inception.

7.02 Overcurrent Protective Device Coordination Analysis

- The manufacturer shall provide an overcurrent protective device coordination analysis to verify that electrical equipment is protected against damage from short-circuit currents. Analysis results shall be used to select appropriately rated protective devices and settings that minimize the impact of short-circuits in the electrical system, by isolating faults as quickly as possible while maintaining power to the rest of the system.
- As applicable, the analysis shall take into account pre-load and ambient-temperature adjustments to fuse minimum-melting curves, transformer magnetizing-inrush current, full-load current, hot-load pick-up, coordination time intervals for series-connected protective devices, and the type of reclosers and their reclosing sequences. Locked-rotor motor starting curves and thermal and mechanical damage curves shall be plotted with the protective-device time-current characteristic curves, as applicable.
- Differing per-unit fault currents on the primary and secondary sides of transformers (attributable to winding connections) shall be taken into consideration in determining the required ratings or settings of the protective devices.
- The time separation between series-connected protective devices, including the upstream (source-side) device and largest downstream (load-side) device, shall be graphically illustrated on log-log paper of standard size. The time-current characteristics of each protective device shall be plotted such that all upstream devices shall be clearly depicted on one sheet.
- The manufacturer shall furnish coordination curves indicating the required ratings or settings of protective devices to demonstrate, to the extent possible, selective coordination. The following information shall be presented on each coordination curve, as applicable:
 - Device identifications.
 - Voltage and current ratios.
 - Transformer through-fault withstand duration curves.
 - Minimum-melting, adjusted, and total-clearing fuse.
 - Cable damage curves.
 - Transformer inrush points.
 - Maximum available fault current, in kA symmetrical, on the utility source side of the incoming feeder or first upstream device.
 - Single-line diagram of the feeder branch under study.
 - A table summarizing the ratings or settings of the protective devices, including:
 - Device identification.

- Relay current-transformer ratios, and tap, time-dial, and instantaneous-pickup settings.
- Circuit-breaker sensor ratings; long-time, short-time, and instantaneous settings; and time bands.
- Fuse type and rating.
- Ground fault pickup and time delay.
- The manufacturer shall use commercially available PC-based computer software such as CYMTCC from CYME international and/or SKM Captor to create the time-current characteristic curves for all protective devices on each feeder.
- As applicable, a technical evaluation shall be prepared for areas of the electrical system with inadequate overcurrent protective device coordination, with recommendations for improving coordination.

7.03 Arc-Flash Hazard Analysis

- The manufacturer shall provide an arc-flash hazard analysis to verify that electrical equipment on the system is “electrically safe” for personnel to work on while energized. An arc flash is a flashover of electric current in air from one phase conductor to another phase conductor, or from one phase conductor to ground that can heat the air to 35,000°F. It can vaporize metal and cause severe burns to unprotected workers from direct heat exposure and ignition of improper clothing. And the arc blast resulting from release of the concentrated radiant energy can damage hearing and knock down personnel, causing trauma injuries.
- The arc-flash hazard analysis shall include the following:
 - Identification of equipment locations where an arc-flash hazard analysis is required.
 - Collection of pertinent data at each equipment location, including:
 - Transformer kVA ratings, including voltage, current, percent impedance, winding ratio, and S/R ratio, plus wiring connections.
 - Protective device ratings, including current, time-current characteristics, settings, and time delays.
 - Switchgear data, including conductor phase spacing, type of grounding, and appropriate working distances.
 - Preparation of a single-line diagram model of the system.
 - Preparation of a short-circuit study to determine the three-phase bolted fault current at each location.
 - Preparation of arc-flash calculations in accordance with NFPA 70E and IEEE 1584, including:
 - Calculation of arc current in accordance with applicable guidelines.
 - Determination of protective device total-clearing times based upon the time-current characteristics.
 - Calculation of arc-flash incident energy level based on the protective device total-clearing times and appropriate working distance.
 - Determination of appropriate personal protective equipment in accordance with risk levels defined in NFPA 70E.
 - Calculation of the arc-flash protection boundary distance.
 - Documentation of the results of the analysis, including:
 - Preparation of a written report.
 - Preparation of single-line diagrams.
 - Preparation of arc-flash hazard labels to be affixed to the equipment.
- The manufacturer shall use commercially available PC-based computer software such as the arc-flash module in SKM Power Tools® for Windows to calculate the incident

energy category levels, in accordance with IEEE 1584.

7.04 Analytical Service Site Visits

- The manufacturer shall perform a site walk-down to gather:
 - Transformer ratings, including voltage, current, power, percent impedance, winding ratio, and X/R ratio, plus wiring connections.
 - Protective device ratings, including current, time-current characteristics, settings, and time delays.
 - Switchgear data, including conductor phase spacing, type of grounding, and appropriate working distances.

End of Appendix Section 16311

Section 16320 - PAD MOUNT TRANSFORMER

PART 1 GENERAL:

1.01 Work Included Herein

- A. Pad mount transformer installations.

PART 2 PRODUCTS:

2.01 MANUFACTURER

- A. Acceptable Manufacturers:
 - General Electric
 - Square D
 - Cooper
 - Cutler Hammer

2.02 TESTING

- A. Testing shall be performed in accordance with ANSI C57.12, IEEE standards 48 and 93, NEMA TR1 and TR5, and ASTM D3487.

2.03 SUBMITTALS

- A. Provide complete submittals and shop drawings on the unit including the following:
 1. Shop Drawings and catalog cuts
 2. Sufficient information to determine compliance with specifications.
 3. Include all electrical ratings, nameplate data, impedance, dimensions, weight, mounting, footprint, material, decibel ratings, terminations, temperature rise, no load and full load losses, regulation, overcurrent protection, connection diagrams, fuse sizes, fuse curves with transformer damage points, and accessories.

2.04 POWER TRANSFORMERS

- A. The transformer shall be of the non burning or high flash point liquid filled type. The unit shall be designed for outdoor installation a temperature variations from 0 to 45 degrees Celsius at 5% to 95% relative humidity. Cooling oil shall be in accordance with ASTM D3487.

- B. Transformer shall have the following characteristics:

1.	Continuous rating, KVA	XXX KVA
2.	Number of phases	3
3.	Number of windings	3
4.	Frequency, hertz	60
5.	Impedance, at rated KVA	5.75%
6.	High voltage winding, volts	13,800
7.	Low voltage winding, volts	120/208
8.	Temperature Rise	65° C Resistive and 80° hot spot

- C. Connections:

1.	High-voltage winding	delta
2.	Low-voltage winding	wye
3.	Taps 2 @ +/-2.5%	yes
4.	Basic Insulation Level (BIL)	
5.	high-voltage winding, kV	95
- D. The windings shall have insulation of high dielectric and mechanical strength and shall be arranged to permit free circulation of cooling medium. Proper internal barriers shall be provided and additional insulation shall be provided on end coils to protect against line disturbances. The coils shall be adequately braced to prevent distortion due to any abnormal operating conditions. The windings shall withstand impulses, induced and dielectric test voltage in accordance with ANSI Standard C57.12.00.
- E. The transformers shall be furnished with a primary no-load tap changer. The transformer shall be provided with four (4) approximately 2-1/2% full capacity taps in the high voltage winding, two below and two above normal, brought out to an externally-operated, de-energized tap changer. The tap changer handle shall be capable of being locked in any tap position.
- F. The transformers shall be provided with an indicating dial thermometer, having a range from 0 degrees C. to 1 20 degrees C., indicating the transformer winding temperature.
- G. The transformers shall be furnished with two suitable ground pads on opposite sides near the bottom. The ground pads shall include a flat finished surface with NEMA drilling.
- H. The base of each transformer shall be provided with jacking pads.
- I. The transformers shall be provided with an approved nameplate conforming to the requirements of ANSI Standard C57.12.00.
- J. All windings shall be copper. Fillers or tie downs shall be provided for the coil windings.
- K. Cores shall be rigidly braced grain oriented, non aging silicon steel to minimize losses

2.05 PRIMARY EQUIPMENT

- A. The primary connections shall be dead front. NOTE: Units shall have all dead front features with the exception of bolted spade type primary bushings.
- B. The primary switch shall be a gang operated load break oil immersed disconnect switch.
- C. The primary fuses shall be non load rated dry well mounted current limiting primary fuses.
- D. The entire transformer shall be of a single unit.
- E. One set of spare primary fuses shall be provided for the transformer.
- F. Provide distribution class surge arresters in the primary terminal compartment to protect the transformer primary. The arresters shall be rated at 10kv.

2.06 SECONDARY EQUIPMENT

- A. The low voltage leads shall be brought out of the tank by epoxy, pressure tight bushings, using the standard arrangement per ANSI. The neutral terminal shall be isolated from the transformer tank. A removable bonding jumper shall be provided from the secondary neutral to ground. The bonding jumper shall be sized in accordance with the NEC.

2.07 ENCLOSURE AND DOORS

- A. The enclosure of the transformer shall be of tamper resistant construction with no exposed screws, bolts, or other fastening devices which are externally removable.
- B. The doors shall be designed and constructed to guard against unauthorized entry.
 - 1. The high voltage compartment door shall be latched with captive bolts accessible only after the low voltage door is released and opened.
 - 2. The low voltage door shall have three point latching with a pentahead type captive bolt in the door handle for additional security. Provisions for padlocking the handle shall be included whereby the padlock cannot be engaged until the captive bolt is seated.
 - 3. Access to the tank hand hole shall be only after the low and high voltage compartment doors are opened.
 - 4. A rigid steel partition shall separate the high and low voltage compartments.
 - 5. The doors shall have full return baffles on the edges and have concealed latching mechanisms and hinges to provide maximum resistance to prying or probing with sticks, rods, or wires.
- C. Exothermically weld pad ground conductor to transformer ground pad.
- D. Transformer shall be painted sage green, federal standard 595b, color 14449. (equal is RAL 6021 and Dupont G51531BA). Sand with 220 grit paper, prime with Dupont Vari-Prime, apply 3 coats of Dupont catalyzed urethane color.

2.08 TRANSFORMER TANK

- A. Transformer tank shall be of sealed construction of sufficient strength to withstand a pressure on 7 psi without permanent distortion.
- B. The following shall be provided on the wall on the tank inside of the locked low voltage compartment of the transformer:
 - 1. Drain valve and sampling device
 - 2. Pressure Relief valve
 - 3. Oil filling plug
 - 4. Oil level plug
 - 5. Non corrosive metal nameplate
 - 6. Ground pad
 - 7. Oil Level gage
 - 8. Dial type thermometer
 - 9. Pressure/vacuum gage
- C. The following shall be provided on the wall on the tank inside of the locked high voltage compartment of the transformer:
 - No load tap changer handle
 - Ground pad
 - Bayonet fusing
 - Lightning arresters
- D. On the door of the secondary compartment shall have provisions for mounting a 15 kv rated hot stick. Hot stick shall be provided with transformer.

PART 3 EXECUTION

3.1 INSTALLATION

- A. Install complete transformer pad as indicated on drawings. Pad shall have block outs for minimum of 2 additional primary and 4 additional secondary conduits.
- B. Transformer shall be securely bolted to the concrete foundation pad in accordance with the manufacturer's recommendations.
- C. Exothermically weld pad ground conductor to transformer ground pad.

3.2 TESTING

- A. The manufacturer shall perform the following tests on each transformer prior to shipment and furnish the test results to the UA Electrical Engineer.
 - 1. Resistance measurements, ratios, polarity, and phase relation tests
 - 2. No load core loss and exciting current at rated voltage
 - 3. Impedance and load loss
 - 4. Applied potential test
 - 5. Induced potential test
 - 6. Pressure leak test
 - 7. Audible sound levels
 - 8. Temperature rise
 - 9. Impedance
 - 10. Verification of compliance from prototype testing and conformance verification
- B. Notify the UA Engineer, in writing when the transformers are ready for field testing.
- C. The electrical contractor shall adjust, test, and place the equipment into operation to the complete satisfaction of the UA Electrical Engineer.

End of Section 16320

Section 16425- MOTOR CONTROLLERS AND CONTACTORS**Introduction****Part 1 – General**

- Related Work
 - Section 16195- Electrical Identification.
 - Section 16440- Enclosed Disconnect Switches and Circuit Breakers.
 - Section 16475- Overcurrent Protective Devices.
- Reference
 - The Work under this section is subject to requirements of the Contract Documents including the General Conditions, Supplementary Conditions, and sections under Division 1 General Requirements.
- Description of Work
 - All motors will be provided ready for connections.
 - This Contractor responsible for proper phase relationships, and correct motor rotation.
 - Provide power circuit wiring for each motor from source of supply to terminal box on motor including required intermediate connections at devices such as motor starter, disconnect switches, etc.
 - Provide power circuit disconnects devices unless shown or specified to be furnished by other divisions or the owner.
 - Provide connecting lugs for equipment specified in this Section as well as for equipment furnished by other divisions or the owner.
 - Provide motor starters as specified for motors unless shown or specified to be furnished by other divisions or the owner. VDF drives shall be provided under division 15.
 - Provide control devices shown on motor schedule or as otherwise indicated.
 - Provide control wiring (except temperature control wiring) for operation, control and supervision of motorized equipment including wiring between motor starters and control devices specified and as shown on drawings.
 - Motor control wiring shall be installed in accordance with control wiring diagrams.
 - Motors ½ HP and smaller shall be served with 120 volts, single phase.
 - Motors ¾ HP and larger shall be served with 480 volt, 3 phase.
 - Starters for NEMA rated 460- volt motors 60 HP and above shall be reduced voltage starting type.
 - Reduced voltage starters shall be auto transformer type, closed transition.
- Reference Standards
 - ASME/ANSI A17.1 Safety Code for Elevators and Escalators.
 - NEMA ICS 1 Industrial Control and Systems: General Requirements.
 - NEMA ICS 2 Industrial Control and System: Controllers, Contactors and Overload Relays, rated not more than 200 Volts AC or 750 Volts DC.
 - NEMA AB- 1 Molded Case Circuit Breakers and Molded Case Switches.
 - NEMA KS- 1 Enclosed and Miscellaneous Distribution Equipment Switches (600 Volt Max.)
 - NEMA 250 Enclosures for Electrical Equipment (1000 Volts Maximum)
 - UL 580 Electric Industrial Control Equipment.
 - UL 845 Electric Motor Control Centers.

- Submittals
 - The design shown in the contract documents is based on the first listed manufacturer. If any of the other listed manufacturers are provided the performance of the equipment shall be equal to or exceed the first listed manufacturer and result in clean coordination and an uncompromised distribution system.
 - Shop drawings for equipment provided under this Section.

Part 2 - Products

- Manufacturers
 - Cutler Hammer, Allen Bradley, General Electric, Siemens.
- Motor Control Equipment
 - Motor Starters:
 - Starters to be equipped with temperature compensated bi-metal overload relays with manual reset.
 - Manual starter to have melting alloy thermal overload relay.
 - Thermal units shall be selected on basis of nameplate horsepower, service factor and full load amps for particular motor.
 - Thermal units shall be selected on basis of measured actual full load amps of particular motor. Sizing shall be done with motor and driven device in its final and normal operating condition. Provide temporary heaters for each starter until motor is in proper operating condition, and replace with heaters sized to actual full load amps.
 - Each starter operating at other than 120 volts single phase shall have control transformer providing 120- volt control power to supply connected load plus 100% spare capacity.
 - Transformer shall have fused primary and secondary circuits.
 - Coils and pilot lights to be 120 volt. Provide surge suppressor across coil.
 - Manual starters shall be equipped with pilot light.
 - Starters shall be equipped with the following:
 - “Hand-Off-Auto” (H-O-A) selector switch.
 - 4 NO and 4 NC set of auxiliary contacts.
 - Red pilot light to indicate motor operation.
 - Green pilot light to indicate motor stopped.
 - Amber pilot light to indicate H-O-A switch in auto position.
 - Pilot lights shall be “Push-To-Test” type.
 - NEMA 3R enclosures shall also be gasketed.
 - Multi speed Starters:
 - Multi speed starters shall be equipped same as single-speed starters with addition of:
 - Speed selector switch.
 - “Auto-Off-Low-High” selector switch.
 - Compelling relay.
 - Accelerating relay/timer.
 - Decelerating relay/timer.
 - Reduced Voltage Motor Starters:
 - Autotransformer starter:
 - Closed transition.

- Magnetic Contactors:
 - Magnetic contactors shall be same as magnetic starters, except without overload protection.
- Motor Disconnect Devices:
 - Refer to Section 16440 –Disconnect Switches for disconnect switches not located in motor control centers.
 - Provide disconnect device with type FRN rejection full size fuses rated minimum of 600 volts Connected in line side of each starter.
 - Provide non-fused disconnect device at all motors.
 - Provide non-fused disconnect device at motors located on roof or located on floor different from overcurrent protective device.
 - Disconnect device shall be capable of being locked in open position.
 - Disconnect devices shall be:
 - Heavy-duty safety switch, quick-make, quick-break, horsepower rated.
 - Fused disconnect switches shall be equipped with Class RK-5 time delay fuses.
- Individual Starters and Disconnect Devices
 - Starter and disconnect device shall be installed in common enclosure, combination type, with accessories mounted in enclosure front except as scheduled.
 - Provide padlocking facility for one to three padlocks to lock disconnect in either ON or OFF position with door open or closed.
 - Provide mechanical interlock to prevent opening of door unless disconnect is in OFF position. Provide defeater to by-pass this interlock.
 - Remote disconnect switches for motors supplied from variable frequency drives (VFD) shall be equipped with pivot arm electrical interlock kit consisting of 4 NO and 4 NC contacts. Contacts to break control circuits before main switchblades open and close control circuits after main switchblades close.
 - Enclosures shall be: NEMA 1, NEMA 4X SS or NEMA 3R/12 by the spaces they are installed. NEMA 4X SS enclosures shall be required in, mechanical rooms, the main electrical equipment room, generator room, main emergency electrical room and for enclosures located exposed to the weather.
- Motor Control Centers
 - Motor Control Centers:
 - Install starters and disconnects in motor control centers, except where shown to be remote mounted at motor location.
 - Provide main breaker in the MCC, fully electronic type LSI/LSIG.
 - Motor Control Centers Shall Be:
 - 480Y/277 Volts, 3 phase 4 wire.
 - NEMA 1 enclosure indoors and NEMA 3R gasketed enclosure outdoors.
 - NEMA Class II.
 - NEMA Type B wiring.
 - Structure shall:
 - Consist of one or more vertical sections joined together to form a freestanding assembly.
 - Be minimum of 90" high, 20" wide and 15" deep for front mounted units or 20" deep for back-to-back units.
 - Have base channels with holes for bolting to floor.
 - Be designed to add matching sections on either end at future date.
 - Bus:
 - Bracing at 65,000 amps symmetrical.

- Shall be copper-tin plated.
- Horizontal Bus amp as shown on plans.
- Vertical bus size shall be same size a horizontal bus size.
- 50% Ground Bus size per NEMA standard.
- 400 AMP MCC's shall have each section rated 400 AMP.
- 300 AMP sections are not permitted.

- Wire ways:
 - Horizontal wire ways at top and bottom of structure.
 - Vertical wire way full height of each section.

- Lifting Eyes
 - Provide permanent mounted lifting eyes on all equipments shipped to the site for installation by the Contractor. Lifting eyes shall be heavy duty forged steel, located to facilitate equipment installation and removal and shall not be removed after construction is complete.

Part 3 – Execution

- Installation
 - Provide 120 volts to each temperature control panel.
 - Install disconnects and motor control equipment as indicated. Final location of devices shall be determined in field.
 - Provide NEMA 4 disconnect switches at exterior mounted equipment.
 - Each motor terminal box shall be connected to rigid conduit system with maximum 18" of flexible liquid-tight metal conduit.
 - Provide green wire ground through flexible conduit to interconnect motor frame and rigid conduit system.
 - Check for proper rotation of each motor.
 - Install fuses per manufacturer's instructions.

- Elevator Connections
 - Provide power wiring from source through circuit breaker disconnect to elevator controller to motor.
 - Coordinate entire installation with elevator equipment supplier prior to rough in.
 - Installation shall comply with ASME/ANSI A17.1: Safety Code for Elevators and Escalators.

End of Appendix Section 16425

Section 16435 - SWITCHBOARDS**Introduction****Part 1 - General**

- Reference
 - The work under this section is subject to requirements of the Contract Documents including the General Conditions, Supplementary Conditions, and sections under Division 1 General Requirements.
- Description
 - Contractor shall furnish and install free-standing, dead-front type low-voltage distribution switchboards, utilizing group mounted circuit protective devices.
- Reference Standards
 - ANSI C37.13 – IEEE Standard for Low-Voltage AC Power Circuit Breakers Used in Enclosures
 - ANSI C37.17 – Trip Devices for AC and General Purpose DC Low-Voltage Power Circuit Breakers
 - NEMA PB2 – Dead Front Distribution Switchboards
 - NEMA KS 1 – Enclosed and Miscellaneous Distribution Equipment Switches (600 Volts Maximum)
 - UL 489 – Molded-Case Circuit Breakers, Molded-Case Switches, and Circuit-Breaker Enclosures
 - UL-891 – Dead Front Switchboards
- Submittals
 - Shop Drawings
 - Submit shop drawings for equipment provided under this section
 - Shop drawings shall indicate:
 - Manufacture and model numbers of equipment and devices
 - General arrangement:
 - Plan view indicating overall dimensions, shipping splits and weights
 - Front elevation indicating location of devices and instruments
 - Section through switchgear showing space available for conduits
 - Seismic certification and equipment anchorage details
 - Electrical one-line drawings
 - Short circuit ratings of bus and interrupting rating of lowest rated device
 - Circuit schedules showing feeder circuit identification, device description, including trip unit or fuse clip rating
 - Schematic wiring diagram
 - Cable lug termination device
 - Time current characteristics curves
 - Main breakers
 - Feeder breakers
 - Ground fault relaying
 - Test data
 - Submit power distribution acceptance test reports to Engineer for review and acceptance, prior to energization of equipment.

- Instruction Manuals
 - In addition to Section 16000 – General Electrical Requirements, manual shall include the following:
 - Wiring diagrams for all systems.

Maintenance and Spare Parts

- Provide list of recommended spare parts
- Delivery, Storage, And Handling
 - Upon completion, assembly and testing by manufacturer of equipment specified, should it be found necessary for shipping and installation purposes to disassemble equipment, match-mark parts to facilitate erection in field.
 - Mark crates, boxes and cartons clearly to identify equipment. Show crate, box or carton identification number on shipping invoices.
 - Store switchboard units in clean, dry environment protected from elements. Maintain factory bracing, packaging and wrapping.
 - Handle units in accordance with manufacture's written handling instructions. Lift units only by manufacturers approved means.

Part 2 - Products

- Materials
 - Acceptable Manufactures: Cutler-Hammer, General Electric, Siemens
- Ratings
 - Assembly shall be rated to withstand fault current as shown on drawing
 - Nominal system voltage rating of switchboard shall be as shown on the drawings.
- Construction
 - Switchboard shall consist of vertical sections bolted together. Sides and rear shall be covered with removable bolt-on covers. Provide adequate ventilation within enclosure.
 - Switchboard sections shall be rear aligned. Protective devices shall be group mounted. Devices shall be front removable and load connections front accessible.
 - Assembly shall be provided with adequate lifting means.
 - Switchboard shall be suitable for use as service entrance equipment.
- Bus
 - General
 - Bus bars shall be silver-plated copper.
 - Main horizontal bus bars shall be mounted with all three phases arranged in same vertical plane.
 - Bus sizing shall be based on 65°C over 40°C ambient temperature outside the enclosure.
 - Provide a full capacity neutral bus.
 - Provide copper ground bus, sized per NEMA Standards, extending entire length of switchgear.
 - Bus Bar Connection
 - Bus bar connections shall be bolted.

- Bus joints shall be provided with conical spring-type washers.
- Clamp joints shall not be used.

- Wiring Terminations
 - Provide small wiring, necessary fuse blocks and terminal blocks within switchboard.
 - Control components mounted within assembly, such as fuse blocks, relays, pushbuttons, switches, etc., shall be suitably marked for identification corresponding to appropriate designations on manufacturer's wiring diagrams.
 - Mechanical-type terminals shall be provided for all line and load terminations suitable for copper cable rated for 75°C.
 - Lugs shall be provided in incoming line section for connection of main grounding conductor.
 - Control wire shall be type SIS.
 - Control wire shall be bundled and secured with nylon ties.
 - Insulated locking spade terminals shall be provided for all control connections, except where saddle type terminals are provided integral to a device.
 - Current transformer secondary leads shall be connected to short-circuit terminal blocks.
 - Groups of control wires leaving the switchboard shall be provided with terminals blocks with suitable numbering strips. Provide wire markers at each end of control wiring.

- Protective Devices
 - Main Breaker
 - Main breaker shall be fixed insulated case circuit breaker, fully electronic, LSIG/LSI.
 - Breaker shall be listed for 100% continuous ampere rating.
 - Main breaker shall be provided with solid-state trip units.
 - Frame ampere ratings shall be as shown on drawings.
 - Main breakers shall be manually operated (MO).

 - Feeder Breakers
 - Feeder breakers shall be fully electronic molded case circuit breakers or Power Circuit Breakers, LSI. Thermal magnetic breakers are not acceptable.
 - Circuit breakers shall have minimum of symmetrical interrupting capacity as indicated on drawings.
 - Circuit breakers 200-ampere through 2500-ampere shall have microprocessor-based RMS sensing trip units.

 - Solid State Trip Units
 - Provide breakers, with solid-state microprocessor based trip units.
 - Unit shall consist of current sensors, solid-state trip device, flux transfer shunt trip and solid-state adjustable time/current curve shaping elements.
 - Solid state elements shall provide:
 - Long time current pickup settings and long time delay bands.
 - Short time current pickup settings and short time delay bands.
 - Instantaneous trip settings with switchable 12t ramp.
 - Ground fault pickup settings (where indicated on drawings).
 - Adjustments shall be made using non-removable, discrete steps.
 - Sealable transparent cover shall be provided over adjustments.
 - Ground Fault (where indicated on drawings):
 - Trip shall be provided as an integral part of breaker.
 - Pick-up shall be adjustable with maximum setting of 1200 amps.
 - Time delay shall be adjustable.

- Trip unit shall contain means to conduct circuit breaker tests.
- Breaker shall be equipped with externally accessible test points to be used for field testing.
- Customer Metering
 - Provide customer metering compartment with hinged door.
 - Current transformers for each meter. Current transformers shall be wired to shorting-type terminal blocks.
 - Potential transformers including primary and secondary fuses with disconnecting means.
 - Meter shall be microprocessor-based as manufactured by Veris.
 - The unit shall display the following:
 - Phase amperes (A, B, C).
 - Phase voltage (A-B, B-C, C-A, A-N, B-N, C-N).
- Enclosures
 - NEMA 1 with sprinkler shield, indoors.
 - NEMA 3R Gasketed Enclosure, indoors and outdoors
 - Finish
 - Exterior and interior of switchboard shall be ANSI-61 light gray. Indoors and sage green outdoors.
- Accessories
 - Lockout Devices:
 - Provide circuit breakers with integral, lockout/tagout devices.
 - Shunt trip devices:
 - Provide shunt trip bell alarms and auxiliary switches.
- Nameplates
 - Nameplates shall be secured to switchboard enclosure with screws.
 - Switchgear assembly:
 - Switchgear shall be provided with nameplate indicating manufacturer's name and drawing number.
 - In addition to name and drawing number, provided:
 - Voltage ratings (kV nominal; kV maximum design; kV BIL)
 - Main bus continuous rating (amperes)
 - Short-circuit ratings (amperes, rms symmetrical and Mva three-phase symmetrical)
 - Momentary and fault-closing ratings (amperes, rms asymmetrical)
 - Control components mounted within assembly shall be marked for identification corresponding to appropriate designation on manufacture's drawings.

Part 3 - Execution

- Inspection
 - Visually inspect equipment and components at time of delivery. Submit report to Owner/Engineer with list of items to be corrected.
- Factory Testing
- Standard Factory Tests Shall Be Performed On Equipment Provided Under This Section.

- Switchboard shall be completely assembled, wired, adjusted, and tested at factory.
- Manufacturer shall provide 3-certified copies of factory test reports.
- Installation
 - Contractors shall install equipment per manufacturer's instructions and contract drawings.
 - Assembly shall be provided with adequate lifting means and shall be capable of being moved into installation position and bolted directly to floor without use of floor sills provided floor is level to 1/8 inch per 3-foot distance in any direction. Necessary hardware to secure assembly in place shall be provided by Contractor.
 - Provide 4-inch high housekeeping pad for switchboards as indicated on drawings. Pad footprint shall be size to adequately support switchboard. Bolt switchboard securely to pad.
 - Protect equipment during installation to prevent twisting or deformation, exposure to damaging environments, and work of other trades. Maintain protection until completion of construction.
 - Prior to energization, factory representative shall visually inspect switchgear installation to insure that switches and motor operators are operable and bus connections are complete.
- Field Quality Control
 - Contractor shall perform field adjustments of protective devices as required to place equipment in final operating condition. Settings shall be in accordance with approved short-circuit study, protective device evaluation study and protective device coordination study.
 - Necessary field settings of devices and adjustments and minor modifications to equipment to accomplish conformance with approved short circuit and protective device coordination study shall be carried out by Contractor at no additional cost to Owner.
 - Immediately prior to final inspection, thoroughly clean equipment. Refinish damaged enclosures to original quality.
- Acceptance Testing
 - Perform acceptance tests on switchboard in accordance with contract documents – Power Distribution Acceptance Tests. Adjust or replace equipment as needed to comply with manufacturer's specifications. Re-test device and submit new test reports.
 - Equipment shall have passed acceptance tests prior to energization.
 - Certified test report of standard production tests shall be available to Engineer upon request.
 - Switch operators shall be tested at least once after energization.
- Training
 - Contractor shall provide training session for up to [XXX] Owner's Representatives for one normal workday at a jobsite location determined by Owner.
 - Training session shall be conducted by Manufacturer's Qualified Representative. Training program shall consist of instruction on operation of assembly, circuit breakers, fused switches, and major components within assembly.

End of Appendix Section 16435

DIVISON 16 ELECTRICAL**Section 16620A Diesel Engine Generator Set**

Note:

- All items shown in red require review, and possible input, for information required that is specific to the generator system being specified.
- The items shown with **{brackets like this}** are included for the purpose of establishing the levels of performance, quality and reliability required for the specified product, and ensuring the reputability of the product supplier.
- The brackets should be removed in any final specification.

Part: 1 GENERAL**1.1. DESCRIPTION OF SYSTEM**

- 1.1.1. Provide a Standby power system to supply electrical power in event of failure of normal supply, consisting of a liquid cooled engine, an AC alternator and system controls with all necessary accessories for a complete operating system, including but not limited to the items as specified hereinafter.

1.2. REQUIREMENTS OF REGULATORY AGENCIES

- 1.2.1. An electric generating system, consisting of a prime mover, generator, governor, coupling and all controls, must have been tested, as a complete unit, on a representative engineering prototype model of the equipment to be sold.
- 1.2.2. Conform to N.E.C. and applicable inspection authorities. NFPA 110

1.3. MANUFACTURER QUALIFICATIONS

- 1.3.1. This system shall be manufactured by GENERAC, Cummins, Caterpillar or approved equal who has been regularly engaged in the production of engine-alternator sets, and associated controls for a minimum of twenty years, thereby identifying one source of supply and responsibility.
- 1.3.2. The manufacturer shall have printed literature and brochures describing the standard series specified, not a one of a kind fabrication.

1.4 DEALER QUALIFICATIONS

- 1.4.1. The supplier of the generator set shall be the authorized dealer for the manufacturer and the installation of the generator set shall be within the authorized dealers assigned territory.

Part: 2 ENGINE-GENERATOR SET**2.1. Engine**

- 2.1.1. The diesel engine shall be a liquid cooled, four (4) cycle design. It shall have turbo-charging and after-cooling as required by the manufacturer to produce the required horsepower in the ambient conditions specified herein. The design may be in line or V type with a minimum displacement adequate to generate the specified kW at manufacturer's published rating. The nominal rating shall be ____ kW, at .80 power factor and operating speed of 1800 RPM. Standard published data sheets must be provided that describe derations applicable to site specific ambient conditions to allow determination of

acceptability of the unit proposed, Interpretation will be determined by the University of Arizona Electrical Engineer. Engine shall be lubricated with a positive displacement oil pump.

- 2.1.2. The engine is to be cooled with a unit mounted radiator, fan, water pump, and closed coolant recovery system providing visual diagnostic means to determine if the system is operating within a normal engine coolant level. The radiator shall be designed for operation in 115° Fahrenheit, ambient temperature.
- 2.1.3. The intake air filter, with replaceable element, must be mounted on the unit. Full pressure lubrication shall be supplied by a positive displacement lube oil pump. The engine shall have a replaceable oil filter with internal bypass. Engine coolant and oil drain extensions must be provided to outside of the mounting base for cleaner and more convenient engine servicing. The fan and all rotating parts must have guards installed for personnel safety.
- 2.1.4. The engine shall have a battery charging DC alternator with a solid state voltage regulator. Remote 2-wire starting shall be by means of a solenoid shift, electric starter.
- 2.1.5. Engine speed shall be governed by electronic isochronous governor to maintain alternator frequency within $\pm .5\%$ from no load to full load alternator output. Steady state regulation is to be $\pm .25\%$.
- 2.1.6. The engine fuel system shall be designed for operation on No. 2 diesel fuel. A secondary fuel filter, water separator, manual fuel priming pump, fuel shutoff solenoid and all fuel lines must be installed at the point of manufacture.
- 2.1.7. Sensing elements to be located on the engine for low oil pressure shutdown, high coolant temperature shutdown, low coolant level shutdown, overspeed shutdown and overcrank shutdown. These sensors are to be connected to the control panel using a wiring harness with wire number labeling on each end of the wire run for easy identification. A molded rubber boot to cover the electrical connection on each sensor to prevent corrosion and all wiring to be run in flexible conduit for protection from the environment and external impact.
- 2.1.8. Provide the following items installed at the factory:
 - 2.1.8.1. A heavy duty, lead acid battery set shall be provided by the generator set manufacturer of adequate voltage and amperage capacity to start and operate the engine. Provide all inter-cell and connecting battery cables as required.
 - 2.1.8.2. Provide an automatic dual rate battery charger with an automatic equalizer system to monitor and limit the charge current to 10 amps. Provide an Ammeter and Voltmeter on the face of the charger, and a replaceable fuse accessible from the front of the automatic battery charger.
 - 2.1.8.3. Primary diesel fuel filter capable of removing contaminants of 10 microns or larger. Element shall be replaceable cartridge type.
 - 2.1.8.4. The manufacturer shall supply its recommended stainless steel, flexible connector to couple the engine exhaust to the exhaust system.
 - 2.1.8.5. The engine shall have a unit mounted, thermostatically controlled water jacket heater as an aid for quick starting. It will be of adequate wattage as recommended by the engine manufacturer. The contractor shall provide proper branch circuit from normal utility power source.
- 2.1.9. The fuel system shall include a double walled, UL approved, sub-base mounted fuel tank with electrical stub-up area. The fuel tank shall provide for a minimum of 24 hours run time at 100% of full load. It shall have the structural integrity to support the engine-generator set. Minimum features shall include all welded construction, fuel filler cap, fuel gauge, low fuel level alarm, tank rupture basin

alarm, supply line check valve, fuel supply connection, fuel return connection, main tank vent, rupture basin vent and tank drain fitting. Tank must be pressure tested to 5 PSI during manufacturing. Appropriately sized flexible fuel supply and return lines shall be provided and installed.

- 2.1.10. Appropriate vibration isolation (elastomeric or springs as required) is to be provided between the generator set and the fuel tank base. Additionally, cork/rubber type vibration isolation pads shall be provided for field installation between the fuel tank base mounting rails, and the concrete mounting pad.
- 2.1.11. LUBRICATION SYSTEM
- A. The lubrication oil pump shall be a positive displacement type that is integral with the engine and gear driven from the engine gear train. The system shall incorporate full flow filtration with bypass valve to continue lubrication in the event of filter clogging.
 - B. The bypass valve must be integral with the engine filter base of receptacle. Systems where bypass valves are located in the replaceable oil filter are not acceptable. Pistons shall be oil cooled by continuous jet spray to the underside or inside of the crown and piston pin.
 - C. System shall utilize synthetic lubricants with compatible filtration, and compatible engine seals, approved by the engine manufacturer.
- 2.1.12. GOVERNOR
- A. The engine governor shall control engine speed and transient load response within commercial and ISO 8528 tolerances. It will be selected, installed, and tested by the generator set manufacture.

2.8 GOVERNOR, ELECTRONIC-SPEED CONTROL

- A. The engine governor shall be a Woodward 2301 Electronic Speed Control with EG Electro-Hydraulic Actuator or Barber Coleman Equal. Speed drop shall be externally adjustable from 0 (isochronous) to 10% from no load to full rated load. Steady state frequency regulation shall be +/-0.25 percent

2.2. ALTERNATOR

- 2.2.1. The alternator shall be a 4-pole revolving field type, 12 lead, wired for ____/____ VAC, 3Ø, 60 Hz, brushless with PMG excitation. The stator shall be direct connected to the engine to insure permanent alignment. The generator shall meet temperature rise standards for Class "H" insulation, and operate within Class "F" standards for extended life. All leads must be extended into an AC connection panel. The alternator shall be protected by internal thermal overload protection and an automatic reset field circuit breaker. Maximum temperature rise at the required kW shall not exceed 130° C above 50° C ambient.
- 2.2.2. One step load acceptance shall be 100% of nameplate rating and meet the requirements of NFPA 110 paragraph 5-13.2.6. The generator set and regulator must sustain 300% short circuit current for a minimum of 10 seconds.
- 2.2.3. A solid state digital voltage regulator must be used to control output voltage by varying the exciter magnetic field to provide $\pm 1\%$ regulation during stable load conditions. True RMS sensing shall be utilized. Should an extremely heavy load drop the output frequency, the regulator shall have a Volts/Hertz capability to maximize motor starting ability. The frequency at which drop operation begins must be adjustable, allowing the generator set to be properly matched to the site specific load characteristics insuring optimum system performance. The voltage regulator shall meet MIL-STD-461C Part 9 for radiated and conducted emissions susceptibility when mounted within the alternator standard connection box. The voltage regulator shall be fully encapsulated for protection against moisture or abrasive contamination. It shall be tested to MIL-STD-705 Method 711.1C and salt fog tested to ASTM B117-73

2.29 VOLTAGE REGULATOR - SEALED

- A. The automatic voltage regulator shall be manufactured by the manufacturer of the engine - generator set. The volts/hertz regulator shall sense line-to-line three phases of generator output voltage and exhibit the following characteristics:
1. Generator output voltage maintained within +/- 1% of rated value for any load variation between no load variation and full load variation.
 2. Generator output voltage drift no more than +/- 1/2% of rated value at constant temperature.
 3. Generator output voltage drift no more than +/- 1% of rated value within a 40° change over ambient temperature range of -40° C to 70° C.
 4. Generator frequency change not over ¼ cycle no load to full load and back.
 5. Response time less than 20 milliseconds.
 6. Telephone Influence Factor (TIF) of less than 50.
 7. Electronic Interference/Radio Frequency Interference (EMI/RFI) suppressed to commercial standards.
 8. The regulator shall include the following features:
 - a. Voltage level rheostat to provide generator output voltage adjustment of 25% to +10% of nominal.
 - b. Gain adjustment to provide output voltage compensation for changes in load or frequency.
- 2.2.4. It is the responsibility of the generator set supplier to verify that the motor starting ability of the generator set being proposed is capable of handling the maximum starting load as shown on the plans. The maximum voltage dip during any sequence shall not exceed 30%. Mathematical confirmation in writing shall be included with the bid to assure that the generator set proposed is sized appropriately for the specific application. This confirmation shall be performed utilizing the computerized sizing program from the alternator manufacturer.
- 2.2.5. A NEMA 1 panel that is an integral part of the generator set must be provided to allow the installer a convenient location in which to make electrical output connections. An isolated neutral lug must be included by the generator set manufacturer to insure proper sizing.
- 2.2.6. The electric plant shall be mounted with vibration isolators on a welded steel base that shall permit suitable mounting to any level surface. Note: If fuel tank type base is included the spring isolators are to be installed between the generator set rails and the fuel tank. (see 2.1.11.)
- 2.2.7. A fully electronic main line circuit breaker 100% rated with long time, short time adjustments and as shown on the drawings, must be mounted in the AC connection panel. The line side connections are to be made at the factory. A system utilizing a manual reset field circuit breaker and current transformers is unacceptable. Circuit breakers of 1000 amps and above require ground fault. Breaker shall be adjustable for 110% load testing. Refer to Section 2.4.6.
- 2.2.8. Thermal Class 200 magnet wire as described by NEMA Magnet Wire Standard MW 1000, Section MW35-C, shall be used for rotor and stator windings. The windings shall consist of copper magnet wire. All winding insulation materials shall be Class H.

2.3. CONTROLS

- 2.3.1. All engine alternator controls and instrumentation shall be designed, built, wired, tested and shock mounted in a NEMA 1 enclosure to the engine-generator set by the manufacturer. It shall contain panel lighting, a fused DC circuit to protect the controls and a +/-5% voltage adjusting control. This panel must be able to be rotated 90 degrees in either direction for correct installation as the site may require.
- 2.3.2. The engine-generator set shall contain a complete 2 wire automatic engine start-stop control which starts the engine on closing contacts and stop the engine on opening contacts. A programmable cyclic cranking limiter shall be provided to open the starting circuit after five attempts if the engine has not started within that time. Engine control modules must be solid state plug-in type for high reliability and easy service.
- 2.3.3. The panel shall include; analog meters to monitor AC voltage, AC current and AC frequency with a phase selector switch, a mushroom style emergency stop switch, an audible alarm, battery charger fuse, and a programmable engine control and monitoring module.
- 2.3.4. The programmable module shall include: a manual, off, auto switch; four LEDs to indicate 1) Not In Auto, 2) Alarm Active, 3) Generator Running, 4) Generator Ready; a data entry keypad and a digital display panel.
- 2.3.5. The module will store and display all pertinent unit parameters including:
1. Generator Status
 - Current unit status in real time
 2. Instrumentation
 - Real time readouts of the engine and alternator analog values
 - * Oil pressure
 - * Coolant temperature
 - * Fuel level
 - * DC battery voltage
 - * Run time hours
 3. Generator Commands
 - Current engine start/stop status
 4. Alarm Status- Provide Audio Visual Alarm Panel.
 - Current alarm(s) condition
 - * High or low AC voltage
 - * High or low battery voltage
 - * High or low frequency
 - * Low or pre-low oil pressure
 - * Low water level
 - * Low water temperature
 - * High and pre-high engine temperature
 - * High, low and critical low fuel levels (where applicable)
 - * Overcrank
 - * Overspeed
 - * Unit not in "Automatic Mode"
 - * 8 user programmable digital channels
 - * 4 user programmable analog channels
 5. Alarm Log
 - Memory of last fifty alarm events
 6. Operating parameters
 - Access to and manipulation of the current operating parameters and alarm limits
 7. Software Information
 - Version information and module display test function
 8. Overvoltage and undervoltage protection.

2.3.6. The panel must be accessible by PC based software via either standard RS232, RS485 or modem. The software must display the module face, be updated in real time and allow for complete access to all module functions. Communication output and its software must be fully compatible and allow for incorporation into an existing control program.

2.3.7. The following equipment is to be installed at the engine-generator set manufacturer's facility:

2.3.7.1. The panel mounted voltage adjuster must have a shaft locking device to avoid unintentional adjustment.

2.3.8. The following equipment is to be provided by the engine-generator set manufacturer and shipped loose with the unit:

2.3.8.1. Provide an alarm annunciator panel for remote mounting with the following signals indicating status and possible malfunction. The annunciator must have the capability of programming the audible alarms as follows:

LAMP LEGEND	LIGHT	AUDIBLE
Pre-Alarm High Water Temperature	Yellow	Selectable
Pre-alarm Low Oil Pressure	Yellow	Selectable
High Coolant Temp/Low Coolant Level	Red	Yes
Low Oil Pressure	Red	Yes
Low Coolant Temperature	Yellow	Selectable
Low Fuel	Yellow	Selectable
High Battery Voltage	Yellow	No
Not In Auto	Red	Yes
RPM Sensor Loss	Red	Yes
Over Speed	Red	Yes
Low Battery Voltage	Yellow	Yes
Overcrank	Red	Yes
Generator Power	Yellow	No
Normal Utility Power	Green	No
System Ready	Green	No
Alarm Switch Off	Red	No
Generator Running	Yellow	No
Battery Charger Failure	Yellow	Selectable
Emergency Stop	Red	Yes
Communications OK	Green	Yes

The panel shall have an ALARM switch that when moved to the OFF position silences the audible alarm. A TEST/RESET switch must be included to verify the lights are functional and reset any condition after it has cleared inside enclosure.

2.3.9. Engine Start Stop Control- Mushroom Switch

2.3.10. Engine run monitor, simplex CZAM/ZAM, connected into fire alarm loop. Refer to single line diagrams for the project.

2.4. UNIT ACCESSORIES AND MISC.

2.4.1. Weather protective sound attenuating enclosure: The engine-generator set shall be factory enclosed in a 12 gauge steel enclosure constructed with corner posts, uprights and headers. The roof shall aid in the runoff of water and include a drip edge. The enclosure shall be coated with electrostatically applied paint, baked and finished to manufacturers' specifications. The enclosure shall be completely lined with 1" thick, UL 94 HF-1 listed, sound deadening material. This material must be of a self-extinguishing design. The enclosure is to have large, hinged, removable doors to allow access to the engine, alternator and control panel. Hinges and all exposed fasteners will be stainless steel. Each

door will have lockable hardware with identical keys. Padlocks do not meet this specification. The critical silencer shall be included to further reduce the unit sound level. The overall design must be such that sound level is 75dbA at 7 meters (23 feet) or less.

- 2.4.2. Exhaust silencer(s) shall be provided of the size as recommended by the manufacturer and shall be of critical grade to attenuate the sound to the level noted above. It shall be supplied with a flexible, seamless, stainless steel exhaust connection. A rain cap will be supplied to terminate the exhaust pipe. These components must be properly sized to assure operation without excessive back pressure when installed. Maximum back pressure is 6.7 kPa. Pitch piping to drain.
- 2.4.3 Jacket water heater(s) shall be provided to maintain coolant temperature of 32 C (90F) while the engine is idle. Heaters shall accept 208 volt AC single phase power and include adjustable thermostats.
- 2.4.4 ISOLATOR-SPRING TYPE
- A. Steel spring isolators shall be installed between the generator set base and the mounting surface. The isolators shall bolt to the base, and have a waffled or ribbed pad on their bottom surface. The pads shall be resistant to heat and age, and impervious to oil, water, antifreeze, diesel fuel, and cleaning compounds.
- 2.4.5 ENCLOSURE – STANDBY PACKAGE, FULL
- A. The enclosure shall offer protection as specified by OSHA from all moving and hot parts of the engine, generator and radiator. It shall be constructed to allow full access to the engine for maintenance without exposing personnel to any moving machinery. Radiator and radiator fan assembly shall be totally enclosed with lockable door over the radiator cap. The radiator shall be sized to accommodate any resulting air flow restriction. Provision shall be made for a duct flange or perforated metal grill to protect the radiator core. Doors shall be the lift off hingeless type with lockable stainless steel security latches
- B. Louvers shall allow sufficient air flow to allow full load operation of the generator set. The louvers shall be twisted to deflect water and direct noise downward. The enclosure shall satisfy IEC 1P22 requirements for drip proof construction acceptable for outside installation when doors are in place.
- C. The enclosure shall be fitted to the generator set base and isolated from engine vibration. Corners shall be formed and welded to assure strength and rigidity. Sheet metal with minimum thickness of 2.0 mm for enclosure and 1.2 mm for doors shall have no burrs or sharp edges. Inside and outside surfaces shall be finished with a baked high performance enamel. Exposed fasteners shall be minimized with all hardware stainless steel.
- D. Outdoor generator enclosures shall be sage green, Federal standard 595b, 14449.
- 2.4.6 CIRCUIT BREAKER-GENERATOR SET MOUNTED
- A. The circuit breaker shall be mounted and connected in a guarded drip-proof enclosure. Cable lugs shall be provided for customer connections.
- B. One molded case electronic circuit breaker, three pole, single-throw, stationary- mounted with manual operating handle, overload and short circuit trips, complete with cable lugs. Overcurrent trip shall be 100% rated and sized to provide enclosed and ambient temperature compensation. The breaker shall be qualified for 600 volt operation and tested in accordance with UL Standard 489, LSI / LSIg. Breaker shall be adjustable to allow for 110 % output test.
- C. One shunt trip, 24 volt DC, on circuit breaker wired to terminal board.
- D. Three current transformer, 5 ampere secondaries.
- E. One ground connection point.

2.4.7 REMOTE ANNUNCIATOR PANEL

- A. NFPA-99 requirements for remote annunciation shall be satisfied by a remote mounted electro-mechanical panel which includes red and yellow indicating lights and silenceable alarm horn for low oil pressure shutdown, low coolant temperature alarm, high coolant temperature, shutdown, overcrank, overspeed shutdown, battery charger malfunction (via charger switch), generator on load (via customer switch). Install where directed by the University.

2.4.8 WEATHERPROOF SOUND ATTENUATION ENCLOSURE

- A. Enclosure shall be sound attenuating enclosure: the engine-generator set shall be factory enclosed in not less than a 12 gauge steel enclosure constructed with corner posts, uprights and headers. The roof shall aid in the runoff of waste and include a drip edge. The enclosure shall be coated with electrostatically applied paint, baked and finished to manufacturers specifications. The enclosure shall be completely lined with not less than 1: thick, UL 94 HF-1 listed, sound deadening material. This material must be of a self extinguishing design. The critical silencer shall be included to further reduce the unit sound level. The overall design must be such that sound level is 75dbA at 7 meters (23 feet) or less.
- B. Exhaust silencer(s) shall be provided of the size as recommended by the manufacturer and shall be of critical grade to attenuate the sound to the level noted above. It shall be supplied with a flexible, seamless, stainless steel exhaust connection. A rain cap will be supplied to terminate the exhaust pipe. These components must be properly sized to assure operation without excessive back pressure when installed.

Part: 3 AUTOMATIC TRANSFER SWITCH- refer to specific specification for this apparatus.**Part 4 SUBMITTALS**

1.12 SUBMITTALS

- A. Submittals shall include but not be limited to:
1. Component List - A breakdown of all components and options including switch gear.
 2. Technical Data - Manufacturer produced generator set specification or data sheet identifying make and model of engine and generator, and including relevant component design and performance data.
 - a. Engine:
 - Type, aspiration, compression ratio, and combustion cycle.
 - Bore, stroke, displacement, and number of cylinders.
 - Engine lubricating oil capacity.
 - Engine coolant capacity without radiator.
 - Engine coolant capacity with radiator.
 - Coolant pump external resistance (maximum). Where remote radiator is specified
 3. Generator: Model
 - Model
 - Frame
 - Insulation class
 - Number of Leads
 - Weight, total
 - Weight, rotor
 - Air Flow

At rated voltage:
 Efficiency at 0.8 power factor for: 50% load, 75% load, 100% load
 Fault current, 3 phase symmetrical
 Decrement curve

4. Radiator: (High Ambient, Brass)
 Model
 Type
 Coolant capacity, radiator
 Coolant capacity, radiator and engine
 Weight: Dry, Wet

5. System:
 Dimensions: Length, Width, Height
 Weight: Dry, Wet

- Performance in 115°F air, 2400 MSL.

Continuous power rating at 0.8 power factor (KW) kVA rating
 Fuel consumption at standard conditions for:
 50%, 75% and 100% load heat rejection to:
 coolant, after-cooler, exhaust, atmosphere from engine, and atmosphere from
 generator
 Exhaust gas stack temperature
 Exhaust gas components; % NOX, % SO
 Tons particulate/yr/mo at 50%, 100% load
 Verification of 10% overload capability

- B. Transient response of frequency and voltage for the generator set:
- C. Auxiliary Equipment - Specification or data sheets, including switchgear, spring type vibration isolators.
- D. Drawings - General dimensions drawings showing overall generator set measurements, mounting location, and interconnect points for load leads, fuel, exhaust, cooling and drain lines.
- E. Wiring Diagrams - Wiring diagrams, schematics and control panel outline drawings published by the manufacturer in Joint Industrial Council (JIC) format for controls and switchgear showing interconnected points and logic diagrams for use by contractor and owner.
- F. Warranty Statements - Warranty verification published by the manufacturer.
- G. Service - Location and description of supplier's parts and service facility including parts inventory and number of qualified generator set service personnel.

PART 5 EXECUTION

5.1 EXECUTION

- A. The following articles and paragraphs are intended to define acceptable procedures and practices of inspecting, installing, and testing the generator set and associated equipment.

5.2 PREDELIVERY INSPECTION

- A. A pre-delivery inspection must be performed by the system manufacturers' local dealer at the dealer's facility to insure no damage occurred in transit and all genset components, controls, and

switchgear are included as specified herein.

5.3 PREDELIVERY TESTING

- A. Prior to delivery and acceptance, the generator set shall be tested to show it is free of any defects and will start automatically and carry full load with all parasitic and external loads. This testing shall be performed at the facility of the system manufacturer's authorized local dealer.
- B. The testing shall be done on dry type, resistive load banks.
- C. The load banks shall not be dependent on the generator control instruments to read current and voltage on each phase. Rather, the test instrumentation will serve as a check of the generator set meters.
- D. Load bank testing shall be done in the presence of the owner's engineer or his appointed representative. After manufacturers approved break-in procedure, sample oil, change oil and performance testing, forward oil test results to U of A Engineer. Testing shall be for a minimum of 1 hour at 80% load, 1 hr. at 100% load, 2 hrs. at 110% load, 1.0 pf. Demonstrate voltage dips and frequency dips with block loading. Bypass output circuit breaker for 110% testing. Use 125% rated conductors into load bank.
- E. All consumables necessary for testing shall be furnished by the bidder. Any defects which become evident during the test shall be corrected by the bidder at his own expense prior to shipment to the jobsite.

5.4 SHIPMENT TO JOBSITE

- A. Delivery shall be FOB to the jobsite by the system manufacturer's authorized dealer.

5.5 INSTALLATION

- A. The installation shall be performed in accordance with shop drawings, specifications, and the manufacturer's instructions.

5.6 FIELD QUALITY CONTROL

- A. The complete installation shall be checked for procedural and operational compliance by a representative of the system manufacturer's authorized local dealer. The engine lubricating oil and antifreeze, as recommended by the system manufacturer, shall be provided by the generator set dealer. If switchgear and generator sets are furnished by different manufacturers, technical representatives of both manufacturers' authorized dealers shall verify the installation meets requirements. Any deficiencies shall be noted and corrected by the Contractor.
- B. The system manufacturer's dealer representative shall be present to assist the Contractor during start-up, systems check, adjusting, and site testing required after the installation is complete. Re run the pre delivery test and then test the oil. (Do not change the oil.)

5.7 POST-INSTALLATION TESTING

- A. Following installation, the following tests shall be performed by the system manufacturer's local dealer representative(s) in the presence of the owner's engineer or designated appointee.

5.8 PRESTART CHECKS

- Oil level
- Water level
- Day tank fuel level

Battery connection and charge condition
Air start supply pressure (if so equipped)
Engine to control interconnects
Engine generator intake/exhaust obstructions
Removal of all packing materials

5.9 OPERATION

- A. Load - two hours operation at 80% of full load rating. One hour operation at 100% of full load rating and one hour at 110°C. After the first half-hour stabilization period at full load, the following shall be recorded at fifteen minute intervals (starting at time equals "zero"):
1. Voltage, amperage, frequency
 2. Fuel pressure, oil pressure and water temperature
 3. Exhaust gas temperature at engine exhaust outlet
 4. Ambient temperature
- B. If equipped with appropriate instrumentation:
1. Kilowatts
 2. Power Factor
 3. KVARs
 4. Generator Temperature
- C. Proper operation of controls, engine shutdown, and safety devices shall be demonstrated.

5.10 ORIENTATION

- A. The system manufacturer's authorized dealer shall provide a complete orientation for the owner's engineering and maintenance personnel. Orientation shall include both classroom and hands-on instruction. Topics covered shall include control operation, schematics, wiring and diagrams, meters, indicators, warning lights, shutdown system and routine maintenance.

5.11 SERVICE MANUALS AND PARTS BOOKS

- A. The system manufacturer's authorized local dealer shall furnish three copies each of the manuals and books listed below for each unit under this contract:
1. OPERATING INSTRUCTIONS - with description and illustration of all switchgear controls and indicators and engine and generator controls.
 2. PARTS BOOKS - that illustrate and list all assemblies, subassemblies and components, except standard fastening hardware (nuts, bolts, washers, etc.).
 3. PREVENTATIVE MAINTENANCE INSTRUCTIONS - on the complete system that cover daily, weekly, monthly, biannual, and annual maintenance requirements and include a complete lubrication chart.
 4. ROUTINE TEST PROCEDURES - for all electronic and electrical circuits and for the main AC generator.

5. TROUBLESHOOTING CHART - covering the complete generator set showing description of trouble, probable cause and suggested remedy.
 6. RECOMMENDED SPARE PARTS LIST - showing all consumables anticipated to be required during routine maintenance and test.
 7. WIRING DIAGRAMS AND SCHEMATICS - showing function of all electrical components.
- B. All manuals and books described above shall be contained in rigid plastic pouches.

5.12 WARRANTY NAMEPLATE

- A. A warranty nameplate of not less than 152 mm x 203 mm (6 in x 8 in) must be affixed to the generator set with the following data:

Warranty Period:
Start-up Date:
Termination Date:
Supplier Name:
Supplier Address:
24-Hour Emergency Number:
Preventive maintenance to be performed by:

5.13 OIL SAMPLING SERVICE

- A. The generator set supplier shall provide a scheduled oil sampling service to monitor engine condition on an ongoing basis. The sampling method shall be of the atomic absorption spectrophotometry method.

Immediate notification of critical results shall be provided to the owner's representative.

Part: 6 UNIT OPTIONS

61. FACTORY TESTING

- 6.1.1. Before shipment of the equipment, the engine-generator set shall be tested under rated load for performance and proper functioning of control and interfacing circuits. Tests shall include:

- 6.1.1.1. Verifying all safety shutdowns are functioning properly.
- 6.1.1.2. Single step load pick-up per NFPA 110-1996, Paragraph 5-13.2.6.
- 6.1.1.3. Transient and voltage dip responses and steady state voltage and speed (frequency) checks.

6.2. OWNER'S MANUALS

- 6.2.1 Three (3) sets of owner's manuals specific to the product supplied must accompany delivery of the equipment. General operating instruction, preventive maintenance, wiring diagrams, schematics and parts exploded views specific to this model must be included. Also include a copy of the manual on CD.

6.3. INSTALLATION

- 6.3.1 Contractor shall install the complete electrical generating system including all fuel connections in accordance with the manufacturer's recommendations as reviewed by the Engineer.

6.4. SERVICE

- 6.4.1. Supplier of the electric plant and associated items shall have permanent service facilities in this trade area. These facilities shall comprise a permanent force of factory trained service personnel on 24 hour call, experienced in servicing this type of equipment, providing warranty and routine maintenance service to afford the owner maximum protection. Delegation of this service responsibility for any of the equipment listed herein will not be considered fulfillment of these specifications.
- 6.4.2. The supplier of the generator set shall include a maintenance contract in a form that is ready for execution by the owner if the owner should choose. The maintenance contract may not be intended for execution by a third party in any form thus ensuring and maintaining sole source and responsibility for all items supplied.

6.5. WARRANTY

- 6.5.1. The standby electric generating system components, complete engine-generator and instrumentation panel shall be warranted by the manufacturer against defective materials and factory workmanship for a period of 5 years. Such defective parts shall be repaired or replaced at the manufacturer's option, free of charge for travel and labor. The warranty period shall commence when the standby power system is first placed into service. Multiple warranties for individual components (engine, alternator, controls, etc.) will not be acceptable. Satisfactory warranty documents must be provided. Also, in the judgment of the specifying authority, the manufacturer supplying the warranty for the complete system must have the necessary financial strength and technical expertise with all components supplied to provide adequate warranty support.

The execution of all warranty shall be conducted by the generator set supplier thus assuring a single source of responsibility.

The manufacturer shall include the option for any extended warranties that may be available in the bid. Any added cost and conditions for this option shall be clearly stated.

6.6. STARTUP AND CHECKOUT

- 6.6.1. At the jobsite.
- 6.6.1.1. Ensuring the engine starts within the specified time.
 - 6.6.1.2. Verification of engine parameters within specification.
 - 6.6.1.3. Set no load frequency and voltage.
 - 6.6.1.4. Test all automatic shutdowns of the engine-generator.
 - 6.6.1.5. Perform a load test of the electric plant, ensuring full load frequency and voltage are within specification by using building load.
 - 6.6.1.6. After the above tests are completed satisfactorily a four hour full load test utilizing resistive load banks shall be conducted. Logging of pertinent data every fifteen minutes shall be included. The load test format shall be approved by the engineer before the test commenced. Initial fuel fill and fuel for testing shall be provided by the owner.

6.7. SUBMITTALS

- 6.7.1. Provide seven complete sets of Engineering Submittal for approval, prior to production release, showing all components, in addition to the engine and generator. Submittals shall include a statement of compliance with these specifications.

6.8. SUBSTITUTIONS

- 6.8.1. The Standby power system has been designed to the specified manufacturer's electrical and physical characteristics. The equipment sizing, spacing, amounts, electrical wiring, ventilation equipment, fuel and exhaust components have all been sized and designed around the basis of design Engine Generator. Should any substitutions be made, the contractor shall bear responsibility for the installation, coordination and operation of the system as well as any engineering and redesign costs which may result from such substitutions. Alternate equipment suppliers shall furnish equipment submittals 14 days prior to bid date for approval to bid. As part of the submittals, the substitute manufacturer shall supply as a minimum engine, alternator and control panel wiring diagrams and schematics.

End of Appendix Section 16620A

Section 16620B - NATURAL GAS ENGINE GENERATOR SET

PART I-GENERAL

1.1 GENERAL

PROJECT NO.

- A. The requirements specified in GENERAL - general requirements of this project shall apply to and govern the work under CSI Division I except where indicated in the following articles.

1.2 WORK INCLUDED

- A. Provide all labor, materials and equipment to furnish, install and place in operation a natural gas power generation system in accordance with the contract documents and manufacturer's drawings and installation instructions. These specifications also describe requirements for the design, fabrication and testing of the power system. The total installation shall conform to manufacturer's recommendations.
- B. The installation of the power generation system shall include the following:
 - Engine-driven generator set
 - Control system
 - Cooling system
 - Connection to natural gas system
 - Generator set accessories
 - Mounting system
 - System control and switchgear
 - Base slab and vibration isolation
 - Weatherproof housing, sound attenuated

1.3 RELATED WORK

Refer to the following specifications for related mechanical and electrical considerations:

- Section 16000 - Electrical Work
- Section 16260 - Automatic Transfer Switch

1.4 SYSTEM DESCRIPTION

- A. The electric power generating system shall have a site capability of xxx kw, xxx kva, under continuous standby operation.
- B. The system shall consist of a natural gas generator set which includes all controls, protection, output circuit breaker, wiring, and accessories for automatic start-stop operation.
- C. The overload capability shall be in excess of this rating, at extreme limits of parameters specified, for not less than 1 hour.

Where air temperature extremes are not the case, test results will be extrapolated. The results shall be as interpreted by the University of Arizona Electrical Engineer.

- D. The generator set shall include the capability of automatically controlling generator set operation. After starting, the unit will attain rated speed and voltage, and accept rated load. Generator set speed shall be controlled by the engine governor, while generating output voltage regulation shall be a function of the generator automatic voltage regulator. Manual adjustment of generator

speed and voltage shall be provided.

- E. The generator set start-stop sequence shall be initiated manually or automatically by closing or opening of a contact. The control system shall automatically engage the cranking motor, sense engine starting speed, disengage the motor and arm the engine protection circuit.
- F. The set shall immediately shut down in the event of overspeed, low oil pressure, high water temperature and overcrank. Cause of shutdown shall be indicated by a light annunciator. System logic shall prevent restart until fault is cleared.

There shall be a provision for manual shutdown in the event of an emergency.

1.5 SITE CONDITIONS

The operating environment of the power generating system shall be:

Altitude	2400 ft.
Engine room temperature, max	125 F
Outside temperature, min	20 F
Outside Temperature max	115 F
Fuel type	Natural Gas
Fuel pressure (gas)	Verify pressure for specific site by contacting PDC

1.6 SYSTEM PERFORMANCE, GENERAL

- A. The power generating system shall conform to the following performance criteria:
 - 1 Rating - Engine brake horsepower shall be sufficient to deliver full rated generator set KW/KVA at the installation site when operated at rated rpm and equipped with all engine-mounted parasitic and external loads such as radiator fans and power generators.
 - 2. The Gas engine shall be able to deliver rated power when operating on dry natural gas having a low heating value (LHV) of 905 Btu/cu ft (33.74 kJ/L).
 - 3. Gas Engine fuel rates shall be based on fuel having a low heating value (LHV) of 905 Btu/cu ft. (33.74 kJ/L).
 - 4. Start Time and Load Acceptance - Engines shall start, achieve rated voltage and frequency, and be capable of accepting load within 10 seconds when properly equipped and maintained.
 - 5. Block Load Acceptance - Transient response shall conform to ISO 8528 requirements.
- B. The power generating system shall satisfy the following performance criteria at site conditions:

Total Power Capability	xxx Kw
Frequency	60 Hz
Voltage	480/277/1/3 phase 4 wire
Voltage Dip starting Largest Motor sequence	20%
Power Factor	0.8
Overload for 1 Hour	10%
- C. The individual generator set shall exhibit the following performance capability: Caterpillar xxx model. Other manufacturer's are Waukesha, Cummings, Onan, Generc, prior approved. Contact Robert Cousy, P.E., (621-9252) for approval prior to bid due date.

1.7 QUALITY ASSURANCE

- A. The complete power generation system, including engine, generator, and switchgear shall be the

product of one manufacturer who has been regularly engaged in the production of complete generating systems for at least 10 years. All components shall have been designed to achieve optimum physical and performance compatibility and prototype tested to prove integrated design capability. The complete system shall have been factory fabricated, assembled, and production tested as performed by Caterpillar, or prior approved systems.

1.8 RESPONSIBILITY

- A. The responsibility for performance to this specification shall not be divided among individual component manufacturers, but must be assumed solely by the primary manufacturer. This includes generating system design, manufacture, test, and having a local supplier responsible for service, parts, and warranty for the total system.

1.9 SUBASSEMBLY AND PACKAGING

- A. Generator set mounted subassemblies such as cooling system, base, air intake system, exhaust outlet fittings, and generator set mounted controls and switchgear shall also be designed, built, and assembled as a complete unit by the engine - generator manufacturer.

1.10 PRODUCTION TESTS

- A. The system manufacturer shall perform post production tests on the generator set supplied. A certified report of these tests shall be available when requested at the time of the generator set order.

1.11 DRAWINGS/SCHEMATICS

- A. All installation drawings and wiring diagrams for the generator set, controls, and switchgear must conform to a common format of 8 ½" x 11", 11" x 17" and 24" x 36".

1.12 SUBMITTALS

- A. Submittals shall include but not be limited to:
 - 1. Component List - A breakdown of all components and options including switch gear.
 - 2. Technical Data - Manufacturer produced generator set specification or data sheet identifying make and model of engine and generator, and including relevant component design and performance data.
 - a. Engine:
 - Type, aspiration, compression ratio, and combustion cycle.
 - Bore, stroke, displacement, and number of cylinders.
 - Engine lubricating oil capacity.
 - Engine coolant capacity without radiator.
 - Engine coolant capacity with radiator.
 - Coolant pump external resistance (maximum). Where remote radiator is specified
 - 3. Generator: Model
 - Model
 - Frame
 - Insulation class
 - Number of Leads
 - Weight, total
 - Weight, rotor
 - Air Flow

At rated voltage:

Efficiency at 0.8 power factor for: 50% load, 75% load, 100% load
 Fault current, 3 phase symmetrical
 Decrement curve

- 4. Radiator: (High Ambient, Brass)
 Model
 Type
 Coolant capacity, radiator
 Coolant capacity, radiator and engine
 Weight: Dry, Wet

- 5. System:
 Dimensions: Length, Width, Height
 Weight: Dry, Wet

Performance in 115°F air, 2400 MSL.

Continuous power rating at 0.8 power factor (KW) kVA rating
 Fuel consumption at standard conditions for:
 50%, 75% and 100% load Heat rejection to:
 coolant, after-cooler, exhaust, atmosphere from engine, and atmosphere from
 generator
 Exhaust gas stack temperature
 Exhaust gas components; % NOX, % SO
 Tons particulate/yr/mo at 50%, 100% load
 Verification of 10% overload capability

- B. Transient response of frequency and voltage for the generator set:
- C. Auxiliary Equipment - Specification or data sheets, including switchgear, spring type vibration isolators.
- D. Drawings - General dimensions drawings showing overall generator set measurements, mounting location, and interconnect points for load leads, fuel, exhaust, cooling and drain lines.
- E. Wiring Diagrams - Wiring diagrams, schematics and control panel outline drawings published by the manufacturer in Joint Industrial Council (JIC) format for controls and switchgear showing interconnected points and logic diagrams for use by contractor and owner.
- F. Warranty Statements - Warranty verification published by the manufacturer.
- G. Service - Location and description of supplier's parts and service facility including parts inventory and number of qualified generator set service personnel.

1.13 SERVICE AND WARRANTY

- A. The manufacturer shall have a local authorized dealer who can provide factory trained servicemen, the required stock of replacement parts, technical assistance, and warranty administration.
- B. The manufacturer's authorized dealer shall have a parts and service facility within 130 miles of the jobsite.
- C. The generator set supplier shall have factory trained service representatives and tooling

necessary to install, test, maintain, and repair all provided equipment.

1.15 WARRANTY ADMINISTRATION

- A. The manufacturer's authorized dealer shall be capable of administering the manufacturer's and dealer's warranty for all components supplied by the selling dealer (who may or may not be the same as the servicing dealer).

1.16 WARRANTY TERMS

- A. The manufacturer's and dealer's standard warranty shall in no event be for a period of less than two (2) years from date of initial start-up of the system and shall include repair parts, labor, reasonable travel expense necessary for repairs at the jobsite, and expendables (lubricating oil, filters, antifreeze, and other service items made unusable by the defect) used during the course of repair. Running hours shall not be a limiting factor for the system warranty by either the manufacturer or servicing dealer. Submittals received without written warranties as specified will be rejected in their entirety.
- B. The manufacturer's and dealer's extended warranty shall in no event be for a period of less than five (5) years from date of initial start-up of the system or 2500 operating hours, whichever comes first. It shall include repair parts, labor, reasonable travel expense necessary for repairs at the jobsite, and expendables (lubricating oil, filters, antifreeze, and other service items made unusable by the defect) used during the course of repair. Applicable deductible costs shall be specified in the manufacturer's warranty. Submittals received without written warranties as specified will be rejected in their entirety.

1.21 WARRANTY NAMEPLATE

- A. A warranty nameplate of not less than 152 mm x 203 mm (6 in x 8 in) must be affixed to the generator set with the following data:

Warranty Period:
Start-up Date:
Termination Date:
Supplier Name:
Supplier Address:
24-Hour Emergency Number:
Preventive maintenance to be performed by:

1.22 MAINTENANCE CONTRACT

- A. The generator set supplier shall offer a maintenance and repair contract which guarantees all support costs of the specified system. It shall include routine and 24 hour emergency access to a factory account manager to expedite emergency repairs. This shall be priced during the bid process as an additive bid item.
- B. The contract shall protect the user from parts and labor price increases, and shall provide a refund of residual funds at any time of user dissatisfaction. Optional payment schedules shall include fixed rate throughout the life of the contract.

1.23 PARTS AVAILABILITY

- A. The generator set supplier shall have sufficient parts inventory to maintain over the counter availability of at least 90% of any normal wear and tear parts. (Belts, hoses, filters, turbines, pumps, safeties, regulators, injectors, gaskets)

- B. The generator set supplier shall guarantee overnight 100% parts from the time an order is entered with the dealer.

1.24 OIL SAMPLING SERVICE

- A. The generator set supplier shall provide a scheduled oil sampling service to monitor engine condition on an ongoing basis. The sampling method shall be of the atomic absorption spectrophotometry method.

Immediate notification of critical results shall be provided to the owner's representative.

PART 2- PRODUCTS

2.1 PRODUCTS

- A. The following articles and paragraphs are intended to define a power generation system of proven type and design, of current production, and with all components commercially available.
- B. Approved systems, subject to conforming to the Specifications are Caterpillar, Generac and Cummins/Onan.
- C. These products shall be from vendors with factory approval as stocking dealer – distributors with evidence of having supplied and serviced units of equal size and performance for at least 5 years.
- D. Generators shall be designed to provide not less than 110% output, based on specified capacity, for a period of 2 hours at temperature extremes.

2.2 ENGINE

- A. The engine shall be a stationary, liquid cooled, 1800 rpm, four-cycle design, vertical inline or V-type, with Dry exhaust manifolds. It shall have cylinders with minimum displacement of xx liters and be manufactured in the United States.

2.3 ENGINE EQUIPMENT

- A. The engine shall be equipped with air filters, fuel filters and pressure gauge, lubricating oil cooler, filters, and pressure gauge, water pump and temperature gauge, service hour meter, flywheel, and flywheel housing.

2.4 LUBRICATION SYSTEM

- A. The lubrication oil pump shall be a positive displacement type that is integral with the engine and gear driven from the engine gear train. The system shall incorporate full flow filtration with bypass valve to continue lubrication in the event of filter clogging.
- B. The bypass valve must be integral with the engine filter base or receptacle. Systems where bypass valves are located in the replaceable oil filter are not acceptable. Pistons shall be oil cooled by continuous jet spray to the underside or inside of the crown and piston pin.
- C. System shall utilize synthetic lubricants with compatible filtration, and compatible engine seals, approved by the engine manufacturer.

2.5 GASEOUS FUEL SYSTEM

- A. The gaseous fuel system shall consist of gas pressure regulators and carburetors. The carburetor shall be a diaphragm type which includes a load screw for air-fuel ratio adjustment, and throttle body to control the air-fuel mixture to the engine.

2.6 IGNITION SYSTEM

- A. The ignition system shall be the low tension type and consist of magneto, transformers, and spark plugs. The magneto shall be of solid state design and spark plugs will incorporate gold palladium electrodes for reliability and life.

2.7 GOVERNOR

- A. The engine governor shall control engine speed and transient load response within commercial and ISO 8528 tolerances. It will be selected, installed, and tested by the generator set manufacturer.

2.8 GOVERNOR, ELECTRONIC-SPEED CONTROL

- A. The engine governor shall be a Woodward 2301 Electronic Speed Control with EG Electro-Hydraulic Actuator or Barber Coleman Equal. Speed drop shall be externally adjustable from 0 (isochronous) to 10% from no load to full rated load. Steady state frequency regulation shall be ± 0.25 percent.

2.9 COOLING SYSTEM

- A. The engine jacket water cooling system shall be a closed circuit design with provision for filling, expansion, and de-aeration. The cooling pump shall be driven by the engine. Auxiliary coolant pumps required for heat exchangers or separate circuit after cooling shall also be engine driven. Coolant temperature shall be internally regulated to disconnect external cooling systems until operating temperature is achieved.

2.10 RADIATOR, ENGINE-MOUNTED

- A. Heat rejected to the engine jacket water shall be discharged to the atmosphere through a close coupled radiator. The radiator shall be sized to cool the engine continuously while operating at full rated load and at site conditions of 115°F ambient.

2.11 FAN AND BELT GUARDING

- A. The fan, fan drive, and fan belts shall be covered with punched steel mesh guarding for personnel protection. The guarding shall conform to UL 2200.

2.12 BLOWERFAN

- A. The radiator cooling fan shall be a blower type driven from the engine. Air shall be drawn from the engine side and exhausted through the radiator core with no more than 12.7 mm (0.5 in) of water external restriction in addition to core restrictions.

2.13 INLET AIR SYSTEM

- A. The engine air cleaner shall be engine mounted with dry element requiring replacement no more frequently than 250 operating hours or once each year.

2.14 TURBOCHARGING

- A. Only single stage turbo charging shall be allowed.

2.15 AFTERCOOLING

- A. After-cooler core air surfaces shall be coated with a corrosion inhibitor to minimize oxidation.

2.16 EXHAUST SYSTEM

- A. The engine exhaust system shall be installed to discharge combustion gases quickly and silently with minimum restriction. System including silencer shall be designed for minimum restriction, and in no case shall back pressure exceed 6.7 kPa.
- B. Heavy walled piping such as Schedule 40 is preferred, with radii of 90 bends at least 1-1/2 times the pipe diameter. Piping shall be installed with 229 mm (9 in) minimum clearance from combustible material or incorporate appropriate insulation and shielding.
- C. Piping shall be supported and braced to prevent weight or thermal growth being transferred to the engine and flexible expansion fittings provided to accommodate thermal growth. Support dampers and springs shall be included where necessary to isolate vibration. Install in accord with manufacturer's recommendations.
- D. Long runs of pipe shall be pitched away from the engine and water traps installed at the lowest point. Exhaust stacks shall be extended to avoid nuisance fumes and odors. And outlets cut at 45° to minimize noise. Aim outlet to northwest as directed.

2.17 SILENCER-CRITICAL

- A. Provide critical silencer in accordance with Paragraph 2.32 E.
- B. The silencer shall have an end inlet and end outlet.

2.18 PACKAGED SYSTEMS

- A. Submit for individual approval in lieu of Paragraph 2.16.

2.18 ELECTRIC STARTING SYSTEM

- A. The engine starting system shall include 24 volt DC starting motor(s), starter relay, and automatic reset circuit breaker to protect against butt engagement. Batteries shall be maintenance free, lead acid type mounted near the starting motor. A corrosion resistant or coated steel battery rack shall be provided for mounting. Required cables will be furnished and sized to satisfy circuit requirements. The system shall be capable of starting engine within 10 seconds. 12 v systems will be considered for 75 kw or less units by prior approval.

2.19 JACKET WATER HEATER

- A. Jacket water heater(s) shall be provided to maintain coolant temperature of 32 C (90 F) while the engine is idle. Heaters shall accept 208 volt AC single phase power and include adjustable thermostats.

2.20 BATTERIES

- A. Batteries for starting and control shall be selected and supplied by the generator set manufacturer. They shall be a heavy duty SLI lead acid type with through-partition connectors, and housed in a hard rubber or polypropylene case with provision for venting.
- B. Battery warranty shall be the responsibility of the generator set manufacturer.

2.21 ALTERNATOR

- A. An engine mounted belt driven battery charging alternator shall be installed with an automatic voltage regulator. It shall be suitable for heavy duty applications with a rating of 24 volts.

2.22 INSTRUMENTATION-ENGINE

- A. The engine mounted instrument panel shall consist of a shock-mounted formed and welded enclosure primed for coastal environment. Provide Metric/English marked gauges. Gauges shall include: engine oil pressure, oil filter differential, fuel pressure, jacket water temperature, electric service meter and running time meter.

2.23 GENERATOR

- A. The generator shall be equivalent to caterpillar model xxx and shall be rated for standby service at xxx kw, xxx KVA, 0.8 PF, xxx V, three phase, wire, 60 Hz, 1800 rpm.
- B. The generator shall be capable of withstanding a three phase load of 300% rated current for 10 seconds, and sustaining 150% of continuous load current for 2 minutes with field set for normal rated load excitation.
- C. It shall exhibit less than 5% waveform deviation at no load.
- D. Generator efficiencies shall be calculated according to IEC 34-2 Section 4, with all current squared times R losses corrected to 115 F.

2.24 STRUCTURE

- A. The generator shall be close coupled, drip proof and guarded, constructed to NEMA I and IP 22 standards, single bearing, salient pole, revolving field, synchronous type with amortisseur windings in the pole faces of the rotating field.

2.25 MECHANICAL DESIGN - SINGLE BEARING

- A. The generator housing shall be one piece and mount directly to the engine flywheel housing without bolted adaptors.

2.26 WINDINGS

- A. Thermal Class 200 magnet wire as described by NEMA Magnet Wire Standard MW 1000, Section MW 35-C, shall be used for rotor and stator windings. The windings shall consist of copper magnet wire. All winding insulation materials shall be Class H in accordance with BS and IEEE standards.

2.27 OPERATING ENVIRONMENT

- A. The generator shall be designed to operate in a sheltered drip-proof environment.

2.28 EXCITER-PERMANENT MAGNET

- A. The permanent magnet excitation system shall derive excitation current from a pilot exciter mounted on the rotor shaft. It shall enable the generator to sustain 300% of rated current for ten seconds during a fault condition.

2.29 VOLTAGE REGULATOR - SEALED

- A. The automatic voltage regulator shall be manufactured by the manufacturer of the engine -

generator set. The volts/hertz regulator shall sense line-to-line three phases of generator output voltage and exhibit the following characteristics:

1. Generator output voltage maintained within +/- 1% of rated value for any load variation between no load and full load.
2. Generator output voltage drift no more than +/- 1/2% of rated value at constant temperature.
3. Generator output voltage drift no more than **+1-** 1% of rated value within a 40° change over ambient temperature range of -40° C to 70° C.
4. Generator frequency change not over ¼ cycle no load to full load and back.
5. Response time less than 20 milliseconds.
6. Telephone Influence Factor (TIF) of less than 50.
7. Electronic Interference/Radio Frequency Interference (EMI/RFI) suppressed to commercial standards.
8. The regulator shall include the following features:
 - a. Voltage level rheostat to provide generator output voltage adjustment of -25% to +10% of nominal.
 - b. Gain adjustment to provide output voltage compensation for changes in load or frequency.

2.30 MOUNTING BASE-STANDBY PACKAGE

- A. The base shall be constructed of formed "C" section steel members with minimum 6 mm thickness. Corners shall be squared to provide rodent/bird proof joint when enclosure is added. Provision shall be made for four corner lifting. It shall incorporate flexible fuel lines, external oil and coolant drains and external crankcase fumes disposal hose. Support cross members shall add rigidity and allow installation of vibration isolators between base and generator set. Generous space for ground stub-ups between the members shall be provided. The base shall include bottom mounting holes.

2.31 ISOLATOR-SPRING TYPE

- A. Steel spring isolators shall be installed between the generator set base and the mounting surface. The isolators shall bolt to the base, and have a waffled or ribbed pad on their bottom surface. The pads shall be resistant to heat and age, and impervious to oil, water, antifreeze, diesel fuel, and cleaning compounds

2.32 ENCLOSURE - STANDBY PACKAGE, FULL

- A. The enclosure shall offer protection as specified by OSHA from all moving and hot parts of the engine, generator and radiator. It shall be constructed to allow full access to the engine for maintenance without exposing personnel to any moving machinery. Radiator and radiator fan assembly shall be totally enclosed with lockable door over the radiator cap. The radiator shall be sized to accommodate any resulting air flow restrictions. Provision shall be made for a duct flange or perforated metal grill to protect the radiator core. Doors shall be the lift off hingeless type with lockable stainless steel security latches.
- B. Louvers shall allow sufficient air flow to allow full load operation of the generator set. The louvers

shall be twisted to deflect water and direct noise downward. The enclosure shall satisfy IEC 1P22 requirements for drip proof construction acceptable for outside installation when doors are in place.

- C. The enclosure shall be fitted to the generator set base and isolated from engine vibration. Corners shall be formed and welded to assure strength and rigidity. Sheet metal with minimum thickness of 2.0 mm for enclosure and 1.2 mm for doors shall have no burrs or sharp edges. Inside and outside surfaces shall be finished with a baked high performance enamel. Exposed fasteners shall be minimized with all hardware stainless steel.
- D. Outdoor generator enclosures shall be sage green, Federal standard 595b, 14449.

2.32 CONTROLS, PROTECTION AND MONITORING

- A. The controls, protection and monitoring systems of the generator set and its operation shall be the responsibility of the generator set manufacturer. All subsystem components, interfaces, and logic shall be compatible with engine mounted devices.

2.33 AUTOMATIC START-STOP CONTROL

- A. The control panel shall be shock mounted on the generator and have the capability to face either side or the rear of the generator. The 24 volt DC system shall incorporate energize to run logic and include:
 - 1. Control:
 - a. Generator voltage level rheostat and ammeter/voltmeter phase selector switch shall be mounted on the panel door.
 - b. The engine start-stop switch shall be door mounted and include positions for off/reset, manual, automatic and stop.
 - 2. Shutdowns/Annunciation:

The generator set shall shut down and individual red lights shall signal operational faults of high water temperature, low oil pressure, overspeed and overcrank.
 - 3. Monitor:

Monitoring devices shall include AC voltmeter, AC ammeter, ammeter/voltmeter phase select switch, frequency meter, electric hourmeter, oil pressure gauge, and water temperature gauge.
 - 4. Safety Devices:

ISO red emergency stop pushbutton shall be provided, and all controls, annunciation, and monitors labeled with ISO symbols.
 - 5. Cycle Cranking

A cycle crank timer shall provide five 10 second cranking periods separated by 10 second rest periods.
 - 6. Engine Cool Down

A cool down timer shall provide an adjustable 0-30 minute engine running period before shutdown after removal of load set at 15 min.

7. Alarm Module

NFPA-99 requirements for the alarm panel shall be satisfied by a 24 volt DC alarm module mounted in the panel and including red indicating lights and silencable alarm horn to annunciate alarm conditions for high and low coolant temperature, low oil pressure, low DC voltage, and system not in automatic.

8. Battery Charger

The battery charger is to be a solid-state device with adjustable float voltage control. It is to be a constant voltage device with current limit, and it is to include an equalize switch which will allow the battery to be overcharged for maintenance purposes.

9. Overvoltage, Undervoltage and Underfrequency Protection

The controls will include devices to protect against overvoltage, undervoltage, underfrequency and overfrequency output from the generator. This protection must sense voltage and frequency directly and controls which attempt to measure these values by measuring excitation current will not be acceptable.

10. Emergency Stop Switch

The engine controls will be arranged to stop the engine if a remote maintained contact emergency stop switch is depressed. Once the switch has been operated, it should not be possible to start the engine until the stop switch is released. The "Switch Off Normal" indicating lamp on the front of the panel and the remote engine fail alarm must both be activated if the stop switch has been operated.

2.34 CIRCUIT BREAKER-GENERATOR SET MOUNTED

- A. The circuit breaker shall be mounted and connected in a guarded drip-proof enclosure. Cable lugs shall be provided for customer connections.
- B. One molded case electronic circuit breaker, three pole, single-throw, stationary-mounted with manual operating handle, overload and short circuit trips, complete with cable lugs. Overcurrent trip shall be 100% rated and sized to provide enclosed and ambient temperature compensation. The breaker shall be qualified for 600 volt operation and tested in accordance with UL Standard 489, LSI / LSIG. Breaker shall be adjustable to allow for 110% output test.
- C. One shunt trip, 24 volt DC, on circuit breaker wired to terminal board.
- D. Three current transformers, 5 ampere secondaries.
- E. One ground connection point.

2.35 REMOTE ANNUNCIATOR PANEL

- A. NFPA-99 requirements for remote annunciation shall be satisfied by a remote mounted electro-mechanical panel which includes red and yellow indicating lights and silenceable alarm horn for low oil pressure shutdown, low coolant temperature alarm, high coolant temperature, shutdown, overcrank, overspeed shutdown, battery charger malfunction (via charger switch), generator on load (via Customer switch). Install where directed by the University.

2.36 AUTOMATIC TRANSFER SWITCH

- A. The automatic transfer switch shall be as specified in the specification.

2.37 WEATHERPROOF SOUND ATTENUATING ENCLOSURE

- A. Enclosure shall be sound attenuating enclosure: the engine-generator set shall be factory enclosed in not less than a 12 gauge steel enclosure constructed with corner posts, uprights and headers. The roof shall aid in the runoff of water and include a drip edge. The enclosure shall be coated with electrostatically applied paint, baked and finished to manufacturers specifications. The enclosure shall be completely lined with not less than 1" thick, UL 94 HF-1 listed, sound deadening material. This material must be of a self extinguishing design. The critical silencer shall be included to further reduce the unit sound level. The overall design must be such that sound level is 75dbA at 7 meters (23 feet) or less.
- B. Exhaust silencer(s) shall be provided of the size as recommended by the manufacturer and shall be of critical grade to attenuate the sound to the level noted above. It shall be supplied with a flexible, seamless, stainless steel exhaust connection. A rain cap will be supplied to terminate the exhaust pipe. These components must be properly sized to assure operation without excessive back pressure when installed.

PART 3- EXECUTION

3.1 EXECUTION

- A. The following articles and paragraphs are intended to define acceptable procedures and practices of inspecting, installing, and testing the generator set and associated equipment.

3.2 PREDELIVERY INSPECTION

- A. A pre-delivery inspection must be performed by the system manufacturers' local dealer at the dealer's facility to insure no damage occurred in transit and all genset components, controls, and switchgear are included as specified herein.

3.3 PREDELIVERY TESTING

- A. Prior to delivery and acceptance, the generator set shall be tested to show it is free of any defects and will start automatically and carry full load. This testing shall be performed at the facility of the system manufacturer's authorized local dealer.
- B. The testing shall be done on dry type, resistive load banks.
- C. The load banks shall not be dependent on the generator control instruments to read amperage and voltage on each phase. Rather, the test instrumentation will serve as a check of the generator set meters.
- D. Load bank testing shall be done in the presence of the owner's engineer or his appointed representative. After manufacturers approved break-in procedure, sample oil, change oil and performance testing, forward oil test results to U of A Engineer. Testing shall be for a minimum of 1 hour at 80% load, 1 hr. at 100% load, 2 hrs. at 110% load, 1.0 pf. Demonstrate voltage dips and frequency dips with block loading. If breaker trips, record time run at 110°
- E. All consumables necessary for testing shall be furnished by the bidder. Any defects which become evident during the test shall be corrected by the bidder at his own expense prior to shipment to the jobsite.

3.4 SHIPMENT TO JOBSITE

- A. Delivery shall be FOB to the jobsite by the system manufacturer's authorized dealer.

3.5 INSTALLATION

- A. The installation shall be performed in accordance with shop drawings, specifications, and the manufacturer's instructions.

3.6 FIELD QUALITY CONTROL

- A. The complete installation shall be checked for procedural and operational compliance by a representative of the system manufacturer's authorized local dealer. The engine lubricating oil and antifreeze, as recommended by the system manufacturer, shall be provided by the generator set dealer. If switchgear and generator sets are furnished by different manufacturers, technical representatives of both manufacturers' authorized dealers shall verify the installation meets requirements. Any deficiencies shall be noted and corrected by the Contractor.
- B. The system manufacturer's dealer representative shall be present to assist the Contractor during start-up, systems check, adjusting, and site testing required after the installation is complete. Re run the pre delivery test and then test the oil. (Do not change the oil.)

3.7 POST-INSTALLATION TESTING

- A. Following installation, the following tests shall be performed by the system manufacturer's local dealer representative(s) in the presence of the owner's engineer or designated appointee.

3.8 PRESTART CHECKS

- Oil level
- Water level
- Day tank fuel level
- Battery connection and charge condition
- Air start supply pressure (if so equipped)
- Engine to control interconnects
- Engine generator intake/exhaust obstructions
- Removal of all packing materials

3.9 OPERATION

- A. Load - two hours operation at 80% of full load rating. One hour operation at 100% of full load rating and one hour at 110°C. After the first half-hour stabilization period at full load, the following shall be recorded at fifteen minute intervals (starting at time equals "zero"):
 - 1. Voltage, amperage, frequency
 - 2. Fuel pressure, oil pressure and water temperature
 - 3. Exhaust gas temperature at engine exhaust outlet
 - 4. Ambient temperature
- B. If equipped with appropriate instrumentation:
 - 1. Kilowatts
 - 2. Power Factor

3. KVARs
4. Generator Temperature

C. Proper operation of controls, engine shutdown, and safety devices shall be demonstrated.

3.10 ORIENTATION

A. The system manufacturer's authorized dealer shall provide a complete orientation for the owner's engineering and maintenance personnel. Orientation shall include both classroom and hands-on instruction. Topics covered shall include control operation, schematics, wiring and diagrams, meters, indicators, warning lights, shutdown system and routine maintenance.

3.11 SERVICE MANUALS AND PARTS BOOKS

A. The system manufacturer's authorized local dealer shall furnish one copy each of the manuals and books listed below for each unit under this contract:

1. OPERATING INSTRUCTIONS - with description and illustration of all switchgear controls and indicators and engine and generator controls.
2. PARTS BOOKS - that illustrate and list all assemblies, subassemblies and components, except standard fastening hardware (nuts, bolts, washers, etc.).
3. PREVENTATIVE MAINTENANCE INSTRUCTIONS - on the complete system that cover daily, weekly, monthly, biannual, and annual maintenance requirements and include a complete lubrication chart.
4. ROUTINE TEST PROCEDURES - for all electronic and electrical circuits and for the main AC generator.
5. TROUBLESHOOTING CHART - covering the complete generator set showing description of trouble, probable cause and suggested remedy.
6. RECOMMENDED SPARE PARTS LIST - showing all consumables anticipated to be required during routine maintenance and test.
7. WIRING DIAGRAMS AND SCHEMATICS - showing function of all electrical components.

B. All manuals and books described above shall be contained in rigid plastic pouches.

3.12 CONTRACT MAINTENANCE

A. The system manufacturer's authorized dealer shall furnish the owner's engineer with a copy of any contract maintenance agreement negotiated relative to the equipment specified in this section. The contract information shall detail agreed maintenance intervals, work to be performed at each interval, reimbursement schedule for maintenance work, and owner's responsibilities versus dealer's responsibilities.

End of Appendix Section 16620B

Section 16621A - AUTOMATIC TRANSFER SWITCH**Part 1 – General**

- 1.01 One 600 Amp, 3 Phase, 480 Volt Automatic Transfer Switch (ATS) shall be provided with gasketed enclosure. The ATS shall consist of an inherently double throw power transfer switch unit and a control module interconnected to provide complete automatic operation. The operating transfer time* in either direction shall not exceed one-sixth (1/6) of a second.
- 1.02 Refer to Specification 16622 for isolation bypass transfer switches.

Part 2 – Products

- 2.01 The transfer switch unit shall be electrically operated and mechanically held. The electrical operator shall be a single-solenoid mechanism, momentarily energized to minimize power consumption and heat generation. The switch shall be positively locked and unaffected by voltage variations or momentary outages so that contact pressure is maintained at a constant value and temperature rise at the contacts is minimized for maximum reliability and operating life. The switch shall be mechanically interlocked to ensure only one of two possible positions – normal or emergency.
- 2.02 All main contacts shall be silver composition.
- 2.03 Inspection of all contacts (movable and stationary) shall be possible from the front of the switch without disassembly of operating linkages and without disconnection of power conductors. A manual operation handle shall permit the operator to stop the contacts at any point throughout the entire travel to properly inspect and service the contacts when required.
- 2.04 A control module shall direct the operation of the transfer switch. The module's sensing and logic shall be controlled by a built-in microprocessor for maximum reliability, minimum maintenance and inherent digital communications capability. The control module shall be connected to the transfer switch by an interconnecting wiring harness. The harness shall include a keyed disconnect plug to enable the control module to be disconnected from the transfer switch for routine maintenance.
- 2.05 The control panel shall meet or exceed the voltage surge withstand capability in accordance with IEEE standard 472-1974 (ANSI C37, 90a-1974) and the impulse withstand voltage test in accordance with the proposed NEMA Standard ICS 1-109.

* Operating transfer time is the time measured from instant of monitored source deviation to closing of main contacts on an available alternate power source exclusive of any purposefully introduced time delay.

- 2.06 Operation:
- A. The voltage of each phase of the normal source shall be monitored, with pickup adjustable from 85 to 100% and dropout adjustable from 75 to 98% of pickup setting, both in increments of 1%, and shall be fully field-adjustable without the use of any tools, meters or power supplies. Repetitive accuracy of settings shall be +/- 2% or better over an operating temperature range of -20C to -70C. Factory set to pickup at 90% voltage and 95% frequency.

- B. The control module shall include four time delays that are fully adjustable over the entire range as follows:
1. Time delay to override momentary normal source outages to delay all transfer switch and engine starting signals. Adjustable from 0 to 6 seconds. Factory set at 1 second.
 2. Transfer to emergency time delay. Adjustable from 0 to 5 minutes. Factory set at 0 minutes unless indicated otherwise on the plans.
 3. Retransfer to normal time delay. Time delay is automatically bypassed if emergency source fails and normal source is acceptable. Adjustable from 0 to 30 minutes. Factory set at 10 minutes.
 4. Unload running item delay for emergency engine generator cool down. Adjustable from 0 to 60 minutes. Factory set at 15 minutes.
 5. Exercising and cool down clocks.
 6. All standard features commonly shown in manufacturer's literature.
- 2.07 A set of DPDT gold-flashed contacts rated 10 Amps, 48 VDC shall be provided for a low-voltage engine start signal when the normal source fails. The start signal shall prevent dry cranking of the generator by requiring the generator to reach proper output and to run for the duration of the cool down setting regardless of whether the normal source restores before the load is transferred. Also provide a "commit/no commit to transfer" selector switch to select whether the load should be transferred to the emergency generator if the normal source restores before the generator is ready to accept the load.
- 2.08 A momentary-type test switch shall be provided to simulate a normal source failure. Also, terminals for a remote contact which opens to signal the ATS to transfer to emergency and terminals for remote contacts which open to inhibit transfer to emergency and/or retransfer to normal shall be provided.
- 2.09 Output terminals to signal the actual availability of the normal and emergency sources, as determined by the voltage sensing pickup and dropout settings for each source, shall be provided.
- 2.10 One set of auxiliary contacts shall be provided rated 10 Amps, 480 VAC consisting of one contact closed when the ATS is connected to normal and one contact closed when the ATS is connected to emergency. Also, one set of signal lights to indicated when the ATS is connected to normal source and when the ATS is connected to emergency source shall be provided.
- 2.11 See attached sheet 6 figure #1 for maximum allowable dimensions of ATS without enclosure.
- 2.12
1. For each switch provide trouble shooting hints.
 2. For each switch provide O & M manual.
 3. For each switch provide complete ladder schematic.
 4. For each switch provide wiring diagram.
 5. For each switch provide parts list.

2.12 Switching Monitor: Manufacturer shall provide one of the following:

A. Inphase Monitor:

An inphase monitor shall be built-in to the ATS and shall control transfer so that motor load inrush currents do not exceed normal starting currents to avoid nuisance tripping of circuit breakers and possible mechanical damage to motor couplings. The inphase monitor shall operate without external control of electrical loads and without any external control of the power sources. The monitor shall compare the phase relationship and frequency difference between the normal and emergency sources and permit transfer can be accomplished within 60 electrical degrees as determined by monitoring the frequency difference. Inphase transfer shall be accomplished if the sources are within 2 Hz of nominal frequency and 70% or more of nominal voltage.

B. Programmed Monitor:

Monitor shall detect motor decay and provide delayed open transition switching where in phase monitors are provided as part of the software. Provide UofA with codes to activate and deactivate.

2.13 Code Compliance:

The ATS shall conform to the requirements of:

- A. 3 cycle rating in excess of UL 1008 – Standard for Automatic Transfer Switches. (Fully rated.)
- B. UL 1008 – Standard for Automatic Transfer Switches. Optional 3 cycle testing.
- C. NFPA 70 – National Electrical Code including use in emergency and standby systems in accordance with Articles 571, 700, 701 and 702.
- D. NFPA 99 – Essential Electrical Systems for Health Care Facilities.
- E. NFPA 110 – Standard for Emergency and Standby Power Systems.
- F. IEEE Standard 446 – IEEE Recommended Practice for Emergency and Standby Power Systems (Orange Book).
- G. IEEE Standard 241 – IEEE Recommended Practice for Electric Power Systems in commercial buildings (Gray Book).
- H. NEMA Standard ICS – 2-447 – AC Automatic Transfer Switches.
- I. IEC – Standard for Automatic Transfer Switches.
- J. The ATS shall be UL listed in accordance with UL 1008 as follows:
 - 1. Rated in amperes for total system transfer including control of motors, electric-discharge lamps, electric-heating and tungsten-filament lamp loads as referred to in Paragraph 38.13 of UL 1008.

2. Overload and endurance at 480 Volts AC per tables 25.1, 25.2, 27.1 and 27.2 of UL 1008 when enclosed according to Paragraph 1.6.
 3. Temperature rise tests after the overload and endurance tests to confirm the ability of the transfer switches to carry their rated current within the allowable temperature limits.
 4. No welding of contacts. Transfer switch must be electrically operable to alternate source after the withstand current tests.
 5. Dielectric tests at 1960 Volts, RMS, minimum after the withstand current tests.
 6. Additional optional testing for 3 cycle compliance.
- K. The ATS shall be "fully" rated to withstand the RMS symmetrical short circuit current available at the ATS terminals for 3 full cycles, verified by oscillograph testing by an independent test agency, in EXCESS of UL 1008, without series protection of fuses or circuit breakers.

Part 3 Execution

3.01 All production units shall be subjected to the following factory tests:

- A. The complete ATS shall be tested to ensure proper operation of the individual components and correct overall sequence of operation and to ensure that the operating transfer time, voltage, frequency and time delay settings are in compliance with the specification requirements.
- B. The switch shall be subjected to a dielectric strength test per NEMA Standard ICS 1-109.21.
- C. ATS must be monitored by Fire Alarm System and report to the UA fire Safety Shop.

3.02 The manufacturer shall provide a notarized letter certifying compliance with all of the requirements of this specification including compliance with the above codes and standards and withstand current ratings. The certification shall identify by serial number(s) the equipment involved. No exceptions to the specifications other than those stipulated at the time of submittal shall be included in the certification.

3.03 Manufacturer

- A. The ATS manufacturer shall maintain a local service center capable of emergency service or routine preventative maintenance contracts. The manufacturer shall maintain records of each switch by serial number for minimum of 20 years.
- B. The ATS manufacturer shall provide same day emergency parts available to customer.
- C. Whenever the words "AS MAY BE DIRECTED", "SUITABLE", "OR EQUIVALENT", "AS APPROVED", or other words of similar intent and meaning are used implying that judgment, discretion, or decision is to be exercised, it is understood that it is the

judgment, discretion, or decision of the Owner to which the reference is made. All materials and articles necessary for the work are subject to the approval of the Owner.

- D. The following manufacturers are approved, subject to approval, based on conformance to this specification:
- i. Russelectric
 - ii. Others: By prior approval submittal. 3 cycle testing in excess of UL 1008 is required prior to the prior approval submittal.

End of Appendix Section 16621A

Section 16621B- *AUTOMATIC TRANSFER SWITCH, ISOLATION BYPASS TYPE

Part 1 – General

- 1.01 Required capacity, (Refer to Contract Drawings), 3 Phase, 480 Volt Isolation Bypass Automatic Transfer Switch (ATS) shall be provided with enclosure. The ATS shall consist of an inherently double throw power transfer switch unit and a control module interconnected to provide complete automatic operation. The operating transfer time* in either direction shall not exceed one-sixth (1/6) of a second.

Part 2 – Products

- 2.01 The transfer switch unit shall be electrically operated and mechanically held. The electrical operator shall be a single-solenoid mechanism, momentarily energized to minimize power consumption and heat generation. The switch shall be positively locked and unaffected by voltage variations or momentary outages so that contact pressure is maintained at a constant value and temperature rise at the contacts is minimized for maximum reliability and operating life. The switch shall be mechanically interlocked to ensure only one of two possible positions – normal or emergency.
- 2.02 All main contacts shall be silver composition.
- 2.03 Inspection of all contacts (movable and stationary) shall be possible from the front of the switch without disassembly of operating linkages and without disconnection of power conductors. A manual operation handle shall permit the operator to stop the contacts at any point throughout the entire travel to properly inspect and service the contacts when required.
- 2.04 A control module shall direct the operation of the transfer switch. The module's sensing and logic shall be controlled by a built-in microprocessor for maximum reliability, minimum maintenance and inherent digital communications capability. The control module shall be connected to the transfer switch by an interconnecting wiring harness. The harness shall include a keyed disconnect plug to enable the control module to be disconnected from the transfer switch for routine maintenance.
- 2.05 The control panel shall meet or exceed the voltage surge withstand capability in accordance with IEEE standard 472-1974 (ANSI C37, 90a-1974) and the impulse withstand voltage test in accordance with the proposed NEMA Standard ICS 1-109.
- 2.06 Operation:
 - A. The voltage of each phase of the normal source shall be monitored, with pickup adjustable from 85 to 100% and dropout adjustable from 75 to 98% of pickup setting, both in increments of 1%, and shall be fully field-adjustable without the use of any tools, meters or power supplies. Repetitive accuracy of settings shall be +/- 2% or better over an operating temperature range of -20C to -70C. Factory set to pickup at 90% voltage and 95% frequency.

* Operating transfer time is the time measured from instant of monitored source deviation to closing of main contacts on an available alternate power source exclusive of any purposefully introduced time delay.

B. The control module shall include four time delays that are fully adjustable over the entire range as follows:

1. Time delay to override momentary normal source outages to delay all transfer switch and engine starting signals. Adjustable from 0 to 6 seconds. Factory set at 1 second.
2. Transfer to emergency time delay. Adjustable from 0 to 5 minutes. Factory set at 0 minutes unless indicated otherwise on the plans.
3. Retransfer to normal time delay. Time delay is automatically bypassed if emergency source fails and normal source is acceptable. Adjustable from 0 to 30 minutes. Factory set at 10 minutes.
4. Unload running item delay for emergency engine generator cool down. Adjustable from 0 to 60 minutes. Factory set at 15 minutes.

2.07 A set of DPDT gold-flashed contacts rated 10 Amps, 48 VDC shall be provided for a low-voltage engine start signal when the normal source fails. The start signal shall prevent dry cranking of the generator by requiring the generator to reach proper output and to run for the duration of the cool down setting regardless of whether the normal source restores before the load is transferred. Also provide a “commit/no commit to transfer” selector switch to select whether the load should be transferred to the emergency generator if the normal source restores before the generator is ready to accept the load.

2.08 A momentary-type test switch shall be provided to simulate a normal source failure. Also, terminals for a remote contact which opens to signal the ATS to transfer to emergency and terminals for remote contacts which open to inhibit transfer to emergency and/or retransfer to normal shall be provided.

2.09 Output terminals to signal the actual availability of the normal and emergency sources, as determined by the voltage sensing pickup and dropout settings for each source, shall be provided.

2.10 One set of auxiliary contacts shall be provided rated 10 Amps, 480 VAC consisting of one contact closed when the ATS is connected to normal and one contact closed when the ATS is connected to emergency. Also, one set of signal lights to indicated when the ATS is connected to normal source and when the ATS is connected to emergency source shall be provided.

2.11 See attached sheet 6 figure #1 for maximum allowable dimensions of ATS without enclosure.

- 2.12
1. For each switch provide trouble shooting hints.
 2. For each switch provide O & M manual.
 3. For each switch provide complete ladder schematic.
 4. For each switch provide wiring diagram.
 5. For each switch provide parts list.

2.12 Switching Monitor: Manufacturer shall provide one of the following:

A. Inphase Monitor:

An inphase monitor shall be built-in to the ATS and shall control transfer so that motor load inrush currents do not exceed normal starting currents to avoid nuisance tripping of circuit breakers and possible mechanical damage to motor couplings. The inphase monitor shall operate without external control of electrical loads and without any external control of the power sources. The monitor shall compare the phase relationship and frequency difference between the normal and emergency sources and permit transfer can be accomplished within 60 electrical degrees as

determined by monitoring the frequency difference. Inphase transfer shall be accomplished if the sources are within 2 Hz of nominal frequency and 70% or more of nominal voltage.

System shall have the ability to be manually switched to a mode that drops the load long enough to allow motor decay and reenergize on the alternate source. This is where the two sources are utilities, or sourced from the same utility.

B. Programmed Monitor:

Monitor shall detect motor decay and provide delayed open transition switching.

2.13 Code Compliance:

The ATS shall conform to the requirements of:

- C. 3 cycle rating in excess of UL 1008 – Standard for Automatic Transfer Switches. (Fully rated.)
- D. NFPA 70 – National Electrical Code including use in emergency and standby systems in accordance with Articles 571, 700, 701 and 702.
- E. NFPA 99 – Essential Electrical Systems for Health Care Facilities.
- F. NFPA 110 – Standard for Emergency and Standby Power Systems.
- G. IEEE Standard 446 – IEEE Recommended Practice for Emergency and Standby Power Systems (Orange Book).
- H. IEEE Standard 241 – IEEE Recommended Practice for Electric Power Systems in commercial buildings (Gray Book).
- I. NEMA Standard ICS – 2-447 – AC Automatic Transfer Switches.
- J. IEC – Standard for Automatic Transfer Switches.
- K. The ATS shall be UL listed in accordance with UL 1008 as follows:
 - 1. Rated in amperes for total system transfer including control of motors, electric-discharge lamps, electric-heating and tungsten-filament lamp loads as referred to in Paragraph 38.13 of UL 1008.
 - 2. Overload and endurance at 480 Volts AC per tables 25.1, 25.2, 27.1 and 27.2 of UL 1008 when enclosed according to Paragraph 1.6.
 - 3. Temperature rise tests after the overload and endurance tests to confirm the ability of the transfer switches to carry their rated current within the allowable temperature limits.
 - 4. No welding of contacts. Transfer switch must be electrically operable to alternate source after the withstand current tests.
 - 5. Dielectric tests at 1960 Volts, RMS, minimum after the withstand current tests.
 - 6. Additional optional testing for 3 cycle compliance.

- L. The ATS shall be rated to withstand the fault current noted on the contract drawings single line diagram, at the ATS terminals, for 3 full cycles, verified by oscillograph testing by an independent test agency, in EXCESS of UL 1008 without series protection of fuses or circuit breakers.

Part 3 Execution

3.01 All production units shall be subjected to the following factory tests:

- A. The complete ATS shall be tested to ensure proper operation of the individual components and correct overall sequence of operation and to ensure that the operating transfer time, voltage, frequency and time delay settings are in compliance with the specification requirements.
- B. The switch shall be subjected to a dielectric strength test per NEMA Standard ICS 1-109.21.

3.02 The manufacturer shall provide a notarized letter certifying compliance with all of the requirements of this specification including compliance with the above codes and standards and withstand current ratings. The certification shall identify by serial number(s) the equipment involved. No exceptions to the specifications other than those stipulated at the time of submittal shall be included in the certification.

3.03 Manufacturer

- A. The ATS manufacturer shall maintain a local service center capable of emergency service or routine preventative maintenance contracts. The manufacturer shall maintain records of each switch by serial number for minimum of 20 years.
- B. The ATS manufacturer shall provide same day emergency parts available to customer.
- C. Whenever the words “AS MAY BE DIRECTED”, “SUITABLE”, “OR EQUIVALENT”, “AS APPROVED”, or other words of similar intent and meaning are used implying that judgment, discretion, or decision is to be exercised, it is understood that it is the judgment, discretion, or
- D. Decision of the Owner to which the reference is made. All materials and articles necessary for the work are subject to the approval of the Owner.
- E. The following manufacturers are approved, subject to approval, based on conformance to this specification:
 - 1. Russelectric Bypass Isolation Switch.
 - 2. Zenith Bypass Isolation Switch
 - 3. Others: By prior approval submittal. 3 cycle testing in excess of UL 1008 is required prior to the submittal.

End of Appendix Section 16621B

Section 16700- TELECOMMUNICATIONS

Part 1 - General

- 1.1 The scope of this project includes providing all material and labor to install a complete telecommunication system. The systems shall include riser cables, station wiring, terminations, and termination devices and grounding.
- 1.2 In any case where the specifications or drawings are not perfectly clear to contractors submitting a proposal, it is the responsibility of the contractor to obtain clarification from UITS-Infrastructure Services Engineering. The drawings are diagrammatic and are not complete in every detail. The contractor shall be responsible for determining how to perform all indicated work included in the scope of the project and shall not make any additional charges for any work or material required for a complete installation. The drawings and specifications are complementary, and what is called for on one shall be binding as if called for by both.
- 1.3 Coordinate size and location of telecommunications rooms with the architect to be in compliance with this document and NEC Article 800.
- 1.4 For projects which require "Blue Light" emergency phones, refer to Section 16705, Blue Light Phones.
- 1.5 Refer to project plans and specifications for grounding and power requirements.

1.6 General Requirements

- 1.6.1 Codes & License Compliance: The completed installation shall be in compliance with all applicable electrical and fire codes and ordinances, the Williams-Steiger Occupational Safety and Health Act of 1970, and University Standards.
- 1.6.2 Telecommunications contractor must have a current State of Arizona L67 Low Voltage Communications Systems license (or other State of Arizona equivalent), have held the license for a minimum of 4 years, and be a Panduit Certified Installer. Only contractors approved by UITS-Infrastructure Services Engineering will be permitted to perform telecommunications installation work on campus.
- 1.6.3 New & Listed Materials: All materials shall be new and shall be listed as being suitable for the purpose by Underwriters Laboratories, Inc. or equivalent testing agency known to and approved by the University.
- 1.6.4 Workmanship: All work shall be executed according to these specifications in a workmanlike manner and shall present a neat mechanical appearance when complete.
- 1.6.5 Quality Assurance: At least one person directly employed by the prime contractor shall be on site daily to monitor the daily activities of workers to assure the quality of the work performed.
- 1.6.6 Acceptance Inspection: All work must pass functional and workmanship inspections prior to acceptance. The contractor shall make all required corrections, at no additional cost, before the system is put into service.
- 1.6.7 Clean up & Repair: Contractor shall be responsible for cleanup and repair of job site. Damaged false ceilings, pencil or chalk marks, hand prints, gouges and tool makers, plaster dust, etc. shall be repaired, cleaned, removed, or painted as required. Penetrated fire barriers shall be resealed in an approved manner.
- 1.6.8 Submittal: (5 copies required). Complete materials lists, manufacturer's literature, required drawings, and other required information shall be submitted for approval no less than 10 working days before such materials are required to be ordered for the work. UITS-Infrastructure Services Engineering must approve submittal prior to starting the installation. Submit through the Construction Project Manager.
- 1.6.9 Guarantee: Upon completion of the work and acceptance by the University, the contractor shall submit his warranty effective for one year guaranteeing to replace without additional cost to the University any work or material which is found to be defective within the warranty period.
- 1.6.10 Structured Cabling System Warranty: upon request of UITS, contractor shall provide a 15 year

Panduit Certification Plus System Warranty covering the performance of the connectivity hardware and cable used in the structured cabling system.

- 1.6.11 As-Built Drawings & Documents: The contractor shall maintain daily up to date specifications and drawings. The contractor shall submit to UITS-Infrastructure Services a complete set of As-Built drawings showing the location and identification number of all jacks installed as part of the project. As-Built drawings shall be submitted in both hard-copy and AutoCAD format.
- 1.6.12 Changes: No changes shall be made from the work as called for by these specifications and drawings, except by a written order approved by the Construction Project Manager and UITS-Engineering.
- 1.6.13 Splicing: All cable splicing must be done by a qualified cable splicer, with a minimum of 5 years experience splicing large pair count copper cables. The cable splicer's name and qualifications must be submitted to UITS- Engineering for verification and approval prior to any splicing work. Provide a minimum of 48 hours advance notice to UITS- Engineering prior to performing any splicing to existing campus cabling infrastructure.
- 1.6.14 Grounding for telecommunications systems and equipment shall be provided in accordance with the requirements of the most recent version of the National Electrical Code, and with The University of Arizona DSS Manual Specification Section16450.
- 1.6.15 Equipment shall be installed in such a manner that it does not impede the spray pattern of fire sprinkler heads.

1.7 Telecommunications Room Requirements

- 1.7.1 Install floor tile or seal the concrete floor to avoid dust.
- 1.7.2 The minimum recommended ceiling height is 8 feet, 6 inches. Telecom rooms shall not have lift-out type ceilings.
- 1.7.3 When ceiling distribution systems are used, design the telecom rooms with adequate conduit or openings through beams or other obstructions into the accessible ceiling space.
- 1.7.4 Design doorway opening with a minimum opening of 3 ft. wide and 6 ft. 8 inches high, and doors shall be hinged to open outwards.
- 1.7.5 Locate the telecom rooms in areas above the threat of flooding.
- 1.7.6 Provide a No. 6 AWG minimum ground wire in each closet. Terminate ground wire to a 6 inch copper buss bar which has provisions for additional ground connections.
- 1.7.7 Design lighting to provide a minimum equivalent of 50 foot candles measured at 1 meter AFF.
- 1.7.8 Telecom rooms shall be equipped with Cat Card swipe access and keyed to the restricted campus telecommunications key plan, accessible only to personnel authorized by UITS.
- 1.7.9 If possible locate riser closet in the center of the building or within 150 feet of each tenant space. Multiple riser telecom rooms may be required on each floor.
- 1.7.10 In a multi-floor building the telecom rooms shall be aligned vertically. Locate telecom rooms so building structure beams and other trades equipment does not interfere with placing riser sleeves/conduits within six inches from wall.
- 1.7.11 Minimum size for floor (IDF) telecom rooms shall be 9 ft. x 11 ft. Larger sizes may be required for high density applications (more than 300 jacks).
- 1.7.12 Minimum size for main (BET) Building Entrance room shall be 10 ft. x 12 ft. Larger sizes may be required if a large number of telecom rooms are served from the BET, if the BET is also used as an IDF with more than 300 jacks, or if the BET serves more than one building.
- 1.7.13 Line all walls with 3/4 inch, 4 ft. X 8 ft. A-C grade plywood. Plywood shall be treated on all sides with at least two coats of fire resistant paint (white), or shall be fire-rated. The fire-rating label on the plywood shall be left visible.
- 1.7.14 Provide a minimum of one 20A/120V duplex receptacle on each wall of each telecommunications room. Provide a minimum of two 20A/208V L6-20R and one 30A/208V L6-30R receptacles in each telecommunications room. In telecommunications rooms containing more than 192 station cable terminations, provide two additional 20A/208V L6-20R and one 30A/208V L6-30R receptacles. NOTE: In buildings with emergency generator systems, half of the 120V equipment outlets, half of the 20A/208V outlets, and all the 30A/208V outlets are to be connected to the building emergency power system.
- 1.7.15 Telecom rooms shall be provisioned with Uninterruptible Power Supplies (UPS). In buildings with emergency generator backup, battery run time for UPS units shall be a minimum of 20 minutes. In

- buildings without generator backup, battery run time shall be a minimum of 60 minutes. In telecom rooms where the design load for the network equipment exceeds 5000W, UPS units shall be hard-wired, permanent facilities type units installed by a licensed electrical contractor.
- 1.7.16 Entrance conduits to the BET from the outside point of connection to campus cable plant shall consist of a minimum of (4) 4 inch conduits. One of the four conduits shall be filled with (4) 1" innerducts.
 - 1.7.17 Locate riser sleeves/slots on the immediate left side of the closet. This will enhance the use of wall space from left to right. Riser sleeves/slots shall be aligned vertically from floor to floor. Riser sleeves/slots shall be: (4) 4 inch sleeves or 4 in. by 16 in. slots. Additional sleeves may be required in large buildings. All riser sleeves shall have bushings installed for cable protection. Sleeves shall extend 4 inches AFF.
 - 1.7.18 Telecom rooms shall be dedicated to telecommunications equipment and shall not be used as a passageway to other utility rooms. Energy management systems, fire alarm, sound systems, and HVAC control systems equipment shall not be located in the telecommunications closet.
 - 1.7.19 Telecom rooms are not to be used for HVAC piping (other than for equipment located in the room serving the room), plumbing piping, fire sprinkler piping, or electrical riser systems.
 - 1.7.20 Telecom rooms shall not be used for materials storage or for storage of janitorial equipment.
 - 1.7.21 User equipment requiring an attendant, monitoring, or frequent attendance shall not be placed in telecommunications rooms. Fire alarm control panels, energy management panels and other equipment requiring access by trades other than telecommunications shall not be located in telecom rooms. Electrical circuit breaker panels shall not be located in telecom rooms unless the panels are dedicated to the telecom equipment in that room. Servers and other local area network equipment not maintained and managed by UITS shall not be located in telecommunications rooms.
 - 1.7.22 All telecommunications rooms shall be served by the building HVAC system. Temperature in telecommunications rooms that will house active equipment shall be maintained within the range of 64 to 81 degrees F, at not more than 60% relative humidity. Telecommunications rooms shall have dedicated environmental controls, providing conditioning 24 hours a day, 7 days a week.
 - 1.7.23 Telecommunications rooms shall be sized and laid out in such a manner that there is a minimum of 3 ft. clearance in front of all telecommunications equipment, cross connect fields, patch panels, etc.

Part 2 - Description of Work

2.1 Telecom Room Build-Out:

- 2.1.1 Vertical cable runs are to be supported at a maximum of 5 ft. centers. Horizontal cable runs are to be supported at a maximum of 3 ft. centers.
- 2.1.2 Horizontal station cable terminations shall be marked with final University room numbers. Obtain entry cable and riser cable pair count information from UITS Engineering.
- 2.1.3 Metal closed loop D-rings (2, 4, and 6 inch as required) shall be installed in quantities sufficient to produce an orderly quality cable and wire installation for vertical runs within telecommunications rooms (note that D-rings are not an acceptable means of horizontal cable support). Distributing posts are not acceptable.
- 2.1.4 Cables shall be routed in such a way as to minimize interference with cross connect wiring and future equipment additions. Entrance cable shall be routed to and terminated to the bottom group of termination blocks. Horizontal distribution cables shall be routed to and terminated to the top group of termination blocks.
- 2.1.5 Cable management D-rings, brackets, and horizontal and vertical cable managers shall be installed to maintain an orderly appearance for cable or wires running between backboards or to common equipment.
- 2.1.6 Riser cable splice cases are not considered part of a TTB, and shall be located so as not to interfere with backboards or common equipment.
- 2.1.7 All wall mounted equipment shall be securely fastened to the TTB/DTB. Suspension by connection to other equipment is not acceptable.
- 2.1.8 Complete telecommunication room layout drawings shall be included as part of the project submittal. Layout shall be designed to allow all four walls of the telecommunications room to be used for mounting telecommunications equipment.

- 2.1.9 Equipment racks, cable runway and other conductive equipment shall be grounded with a minimum #6 AWG connection to the ground bus in each telecom room. Free standing equipment racks (two post and four post) shall be provided with an equipment rack grounding strip and ESD port. Grounding connections shall be made using two-hole compression lugs.
- 2.1.10 When ceiling distribution systems are used, design the telecom rooms with adequate conduit or openings through beams or other obstructions into the accessible ceiling space.
- 2.1.11 Provide fire stopping for all floor penetrations and all penetrations of fire rated walls/partitions occupied by telecommunications cabling. Fire stopping of existing sleeves/penetrations shall be made using caulk or putty type materials. All new fire-rated sleeves/penetrations shall be made using re-enterable type sleeves. Fire stopping materials shall be UL listed, and shall be installed in accordance with the manufacturer's installation requirements.

2.2 Entrance Cabling:

- 2.2.1 Copper entrance cabling shall be PE-39, Type ANMW, ASP, filled, direct burial, #24 AWG solid conductor, with REA color code.
- 2.2.2 Splice cases and/or closures shall be provided for copper entrance cabling as required, with prior-approval by submittal required. Provide transition splice to non-filled cable prior to building entrance termination.
- 2.2.3 Copper entrance cabling shall be provided with station protectors installed in accordance with NEC 800 requirements.
- 2.2.4 Ground entrance cable shield to an approved provable ground as close to the entrance as possible in accordance with NEC requirements.
- 2.2.5 Terminal blocks shall be permanently marked with pair count numbers for entry cable terminations.
- 2.2.6 Optical fiber entrance cables shall be singlemode 8.2/125 Micron, 900 Micron buffered, OS2 rated.
- 2.2.7 Entrance fiber shall be terminated on a rack mount enclosure. In buildings with legacy ST connectors, new connectors shall be ST. In new buildings, or buildings without legacy optical fiber, new connectors shall be LC.
- 2.2.8 Optical fiber cable construction: provide indoor/outdoor riser rated cable for building entrance cables that are run to a splice case within 300 ft. of the building entrance. For backbone cables traversing more than 300 ft. of outside duct and/or tunnel pathway, cable shall be single armor, double jacket. All outside plant optical fiber cables shall be gel-free, with loose tube construction.
- 2.2.9 Minimum strand count for optical fiber entrance cables shall be 24 strands per building.
- 2.2.10 Ground entrance cable shield to an approved provable ground as close to the entrance as possible in accordance with NEC requirements.
- 2.2.11 All optical fiber cable splicing shall be done using the fusion splice method.
- 2.2.12 All optical fiber connectors shall be hot melt in legacy environments; new installations shall utilize fusion spliced pigtails or fusion-splice connectors. Mechanical ("cam") type connectors are not acceptable.

2.3 Riser Cabling:

- 2.3.1 Fiber Optic Riser Cable shall be OFNR or OFNP, tight buffered.
- 2.3.2 Legacy installations: in buildings with existing 62.5 micron cabling, new multimode riser cabling shall be 62.5/125 micron, with minimum guaranteed gigabit Ethernet performance distance of 300m at 850nm and 550m at 1300nm, with ST hot melt connectors. Singlemode shall be 8.2/125 micron, 900 micron, OS2 rated, with Corning SMF28e glass, with ST hot melt connectors.
- 2.3.3 New installations: in buildings without existing legacy optical fiber cabling, new multimode riser cable shall be 50 micron, OM4 rated, LC connectors. New singlemode riser cable shall be OS2 rated, with LC connectors. Connectors shall be fusion splice-on type, or factory terminated fusion splice pigtails.
- 2.3.4 Provide a minimum strand count of 12MM/12SM to each telecom room on the riser.
- 2.3.5 Optical fiber riser cables shall be terminated on a rack mounted enclosure, unless specifically noted otherwise on project plans and specifications.
- 2.3.6 Multi-pair copper riser cable shall be shielded, type ARMM, 24AWG, solid conductor, Cat. 3 rated, terminated on 110 blocks.

- 2.3.7 Where specified, four pair copper riser cable shall be Cat. 6 rated, as specified for Cat. 6 station cabling, terminated on patch panels.

2.4 Station Wiring:

- 2.4.1 Provide a quad frame for each outlet, with blank inserts provided for unused openings. HORIZONTAL STATION WIRING MUST BE IN COMPLIANCE WITH EIA/TIA-568C HORIZONTAL WIRING DISTANCE SPECIFICATIONS. The maximum horizontal cable length shall be 90 meters (295 ft). This is the cable length from the mechanical termination of the media in the telecommunications closet to the telecommunications outlet in the work area. The distance maximum includes all wiring that is part of the horizontal wiring. Provide 12 in. of cable slack at each outlet, plus an additional 10 ft. of slack in the telecommunications room, neatly arranged in a loop.
- 2.4.2 Station wiring and termination equipment shall be rated Category 6 for all new construction or in existing facilities where the predominant cabling is Category 6. In existing facilities where the predominant cabling is Category 5e or older, Category 5e wiring and termination equipment shall be provided unless specifically noted otherwise in the project plans and/or specifications.
- 2.4.3 Station cable shall be 4 pair, solid conductor, REA color code, plenum rated, UL Listed type "CMP" w/FEP insulation. Cable must comply with EIA/TIA 568C.
- 2.4.4 Station cabling for outdoor installations where the cable is in conduit that is not concrete encased shall be a flooded type cable, and shall be provided with protector modules at both ends where required by code.
- 2.4.5 Outlet jack shall be an eight position modular jack meeting the specifications of FCC Regulations Part 68.500. All jacks shall be wired according to the T568B wiring schematic.
- 2.4.6 Station cable must not be spliced. Cable runs are to be direct home runs to the IDF and shall not pass through any other station outlet box. The cable bend radius for station cabling shall not be less than four times the outside diameter of the cable.
- 2.4.7 Install cables in conduit, and raceways as specified and supplied and installed by the electrical contractor. All conduits and sleeves shall have insulated bushings installed to protect wire and cables from damage. Installed cables shall not be bundled together.
- 2.4.8 Station cable and wiring shall comply with EIA/TIA 568C, standards. (UTP Category 6 or 5e)
- 2.4.9 Install and terminate fiber optic cable station cabling where specifically indicated in the project plans and/or specifications.

2.5 Wiring Practices:

- 2.5.1 Station cables shall terminate on a rack mounted patch panel, in a single unified field (no separate voice and data fields). Terminations performed in existing locations without patch panels may utilize 110 style terminations unless the project plans and/or specifications specifically require patch panel installation.
- 2.5.2 Station cables serving wireless access points shall be grouped together in a given IDF, occupying the last (bottom) positions in a patch panel or 110 block.
- 2.5.3 Wireless access points in hard ceiling areas shall be mounted to a 4" square outlet box, using the manufacturer's mounting plate best suited to minimize the gap between AP and ceiling.
- 2.5.4 Wireless access points in lift-out ceiling areas shall be mounted to the ceiling grid using the manufacturer's ceiling grid clips best suited for the type of grid (recessed or flush). The access points shall be mounted at grid intersection points. An independent means of support (e.g., seismic support wire) shall be run from the building structure above to each access point. Cables for wireless access points shall be terminated on the station end with a female modular jack (not a male RJ-45 plug) to allow standards-compliant permanent link testing.
- 2.5.5 Cable and wire above ceiling shall be run parallel or perpendicular to the walls. Diagonal runs will not be accepted. Riser cables shall be run parallel to riser system. Do not install cables in close proximity to fixtures or equipment that may cause RFI or EMI. To reduce the effects of EMI, the following minimum distances shall be adhered to:
- 5" from power lines of 2kVA or less.
 - 18" from high voltage lighting (including fluorescent).
 - 39" from transformers, motors, and power lines of 5kVA or greater

- 2.5.6 Cables and wire shall not be attached to conduit, pipes, ceiling grid/hanger wire, light fixture hangers, HVAC duct work, etc.
- 2.5.7 All horizontal UTP cable shall be pulled by hand. During pulling operation, an adequate number of workers shall be present to allow cable observation at all points of raceway entry and exit, as well as the point at which cable is "payed out" from the box or reel, and around corners.
- 2.5.8 Pull cables in accordance with manufacturer's recommendations and ANSI/IEEE C2 Standards. Manufacturer recommendations shall be part of cable submittal. Recommended pulling tensions and bend radius shall not be exceeded. Any cables bent or kinked to radius less than recommended dimensions are not allowed and shall be replaced at no expense to the owner.
- 2.5.9 Cables that show signs of being bent or kinked beyond recommendations then straightened are also not allowed and shall be replaced at no expense to the owner.
- 2.5.10 Cables that show damage to the jacket in any manner shall be replaced at no expense to the owner.
- 2.5.11 Cable and wire above ceiling shall be suspended from approved hangers as required and be routed as close to upper ceiling as practical. Supports shall be installed at a maximum of 3 ft. centers using metal "J" hooks or other supports meeting or exceeding Category 5e installation requirements. "D" rings shall not be installed as a means of horizontal cable support.
- 2.5.12 "J Hooks" and other similar cable support devices shall be attached using corrosion resistant screws, #8 minimum. Drywall screws shall not be used for fastening "J-Hooks".
- 2.5.13 Cables shall not be installed in a manner such that they rest upon ceiling tiles, mechanical equipment, and shall not be tie-wrapped to conduit or piping.

2.6 Raceway Requirements:

- 2.6.1 Conduit fill: In new installations, conduit fill shall not exceed 50%. In retrofit installations, conduit fill may exceed 50% provided that the necessary pulling tension does not exceed the cable rating, and that compression of the cable jacket does not occur.
- 2.6.2 All conduits and sleeves must have UL approved insulated end bushings installed prior to installation of cables or station wire.
- 2.6.3 All riser sleeves/conduits and penetrations of fire rated partitions shall be fire stopped using approved methods and materials.
- 2.6.4 All cables shall be installed in compliance with manufacturers pull tension and bend radius specifications.
- 2.6.5 Station cable (voice & data), shall have individual pair twists preserved to point of termination. Cable jacket and inter-pair twists shall be continuous to within 1/2" of termination. Cables should not be routed in tightly cinched bundles. Avoid over-tensioning or twisting cable during installation.
- 2.6.6 Wall boxes shall be flush mounted, standard metal 4 inch square, deep type, with a single gang plaster ring. Conduit from the wall box shall be concealed and stubbed out above accessible ceiling, to riser closet, or to the telecommunications cable tray. Conduit shall be 1" minimum. Conduit end shall be fitted with a UL approved insulated bushing.
- 2.6.7 Any additional service requirements that will not operate over the standard University building telephone/data wiring shall use a completely separate conduit and wall outlet.

2.7 Telecommunications Cable Tray

- 2.7.1 Telecommunications cable trays are for the containment and support of telecommunications cables only. Cable trays shall not be used for the support of electrical power cables and conduits. Cable tray shall be bonded to ground in accordance with electrical code requirements.
- 2.7.2 System shall be designed and installed to allow accessibility for adds, moves, and changes.
- 2.7.3 A standard prefabricated ladder type cable tray consisting of solid side panels and side rails connected by individual transverse members, or an approved wire mesh (basket) type tray shall be used. Ladder type trays shall use standard prefabricated elbows, reducers, crossovers, tees, and elevation change tray sections as required.
- 2.7.4 Trays may be supported by cantilever brackets, trapeze, or individual rod suspension. Supports shall be installed on five foot centers maximum. A support shall be placed within two feet on each side of any connection to a fitting. Center hung supports shall be used only with prior approval from UITS Engineering.

- 2.7.5 The inside of the cable tray shall be free of burrs, sharp edges, and projections that can damage cable insulation.
- 2.7.6 A minimum of 12 inch access headroom shall be provided and maintained above the complete cable tray system. Cable trays must have adequate side access for initial cable installation and for future cable adds, moves, and changes.
- 2.7.7 Cable tray “tees” and 90’s shall have wide radius junctions.
- 2.7.8 Care should be taken to ensure that other building components do not restrict access to the cable tray.
- 2.7.9 Cable tray shall be level and have supports if required to prevent horizontal movement.
- 2.7.10 System shall be designed and installed to allow compliance with EIA/TIA-568C horizontal wiring distance standards.

2.8 Labeling:

- 2.8.1 All labels shall be machine generated (printer or handheld label machine).
- 2.8.2 All cables shall be permanently identified at both ends.
- 2.8.3 The labeling for outlets shall consist of three components: (1) a unique sequential numeric designation for each jack/cable, (2) an alpha-numeric designation for the telecommunications room serving the outlet, and (3) the final University room number. At the station end, the faceplate of each outlet shall be labeled with the alpha-numeric telecommunications room identifier, plus the sequential numeric jack/cable identifier, as shown on the diagram below. At the telecommunications room end, the patch panel shall be labeled with the final University room number, plus the sequential jack/cable identifier. A label with the sequential jack/cable identifier shall be applied to each end of the station cable within 6 inches of the termination.

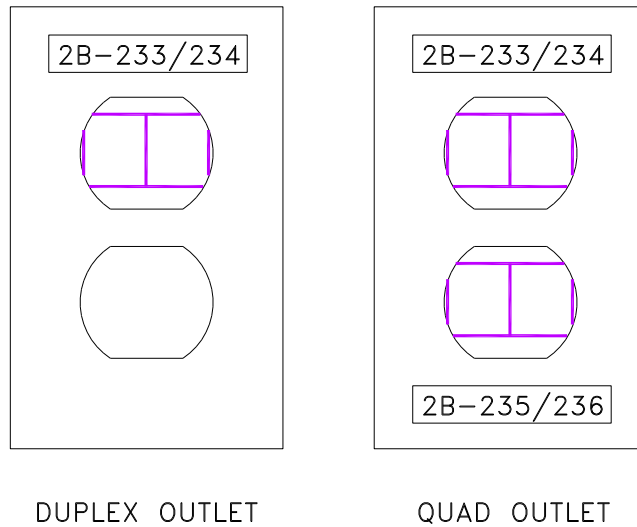

Faceplate Labeling Diagram

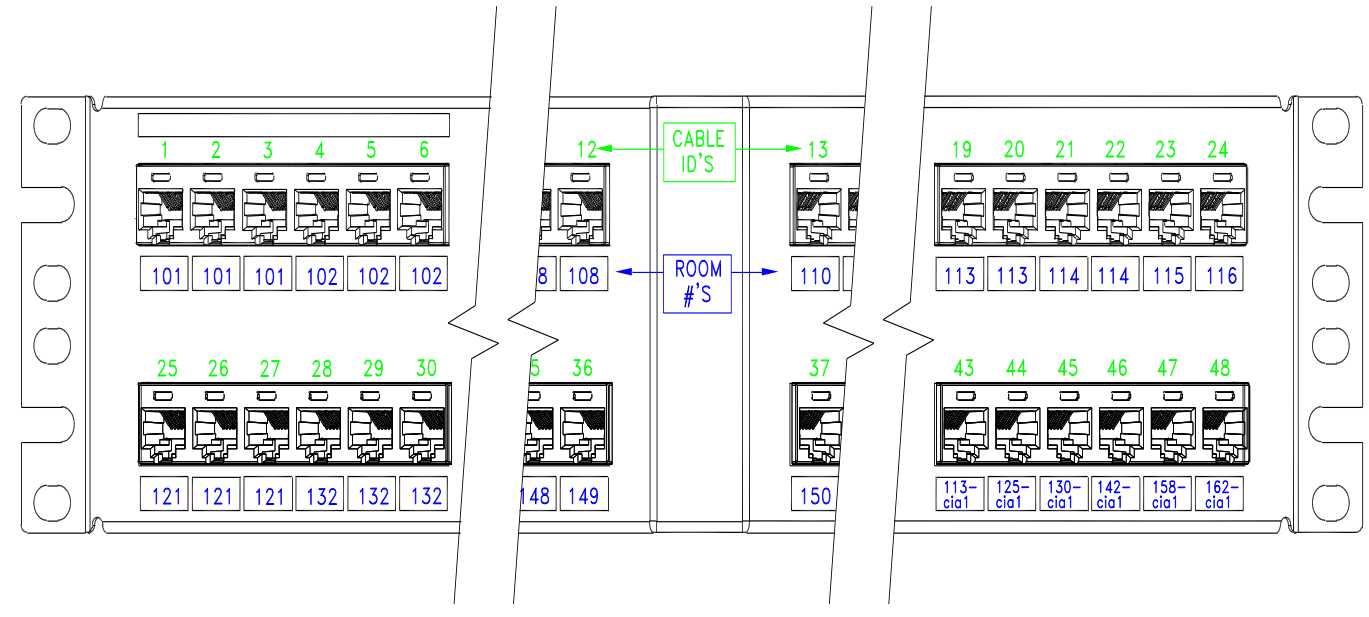

Patch Panel Labeling Diagram

- 2.8.4 Fiber optic riser cables shall be labeled utilizing a unique sequential numeric designation for each strand within a given building. Couplers and coupling panels shall be grouped by type of fiber, adjacent to each other either vertically or horizontally depending on LIU construction, with a designation indicating “SM” for single mode and “MM” for multimode. Each LIU in an IDF shall be labeled with the unique numeric strand designations, and labeled with the originating end Equipment/BET Room designation (alpha-numeric identifier). The LIU(s) in the Equipment/BET Rooms shall be labeled with the unique numeric strand designations, plus each group of fibers shall be labeled with the remote end IDF Room designation (alpha-numeric identifier).
- 2.8.5 The sequential numeric designation for optical fiber strands shall be in the range of 1-999 for singlemode, and 1001-1999 for multimode, starting with 1 and 1001 respectively,
- 2.8.6 Prior approval of final labeling scheme must be received from UITS Infrastructure Services Engineering. Labels shall be applied at the time of cable acceptance testing.

2.9 Outside Plant work

2.9.1 Underground Conduit:

- Underground conduit shall be 4” minimum, unless otherwise specified. Conduit shall be heavy-wall, Schedule 40, UL listed for direct burial and concrete encasement
- Conduit bends shall be sweeps, 12 times the conduit diameter. Bends shall be concrete encased PVC Schedule 40, or rigid galvanized steel double wrapped with 10 mil PVC tape.
- Conduit pole risers shall be rigid galvanized steel from below grade to a minimum of 10’ above grade, mounted to the pole with standoff brackets. Pole riser shall be located in a pole quadrant opposite the traffic side of the pole.
- Conduits shall be installed in continuous sections, with no continuous sections to exceed 500 feet without pull points.
- Conduits shall have no more than three 90 degree sweeps (or 270 degrees total bends) between pull points.
- All conduits shall be mandrel tested prior to acceptance by the University. Conduits that do not pass a mandrel test shall be repaired or replaced and re-tested at no cost to the

University. Notification of mandrel testing shall be provided to the UITs project manager 24 hours in advance of testing, and shall be witnessed by a UITs representative if requested.

- Empty conduits shall be provided with 2500 lb. mule tape with footage markers, secured with at least 4 ft. of slack at each pull point or termination point.
- Underground conduits shall be installed a minimum of 24 inches below grade, separated from other utilities with a minimum of 12" well packed earth, 4" of masonry, or 3" of concrete.
- Provide 6" orange, traceable underground warning tape labeled "Caution- Buried Fiber Optic (or Telephone) Cable Below" above all conduits or duct banks, installed 12" below finished surface.
- Innerducts for use in underground conduits shall be corrugated, PVC, 1" or 1-1/4" as specified.
- Conduits and innerducts shall be sealed at termination points using watertight, corrosion-proof, removable and re-usable duct plugs as manufactured by Jackmoon or equivalent.
- Building entry conduits shall slope downward away from the building.

2.9.2 Maintenance Vaults (Manholes)

- Maintenance vaults shall be dedicated for telecommunications systems use; joint-use with electric or other utilities are not permitted.
- Maintenance vaults shall be pre-cast concrete, with galvanized interior hardware to include entry ladder, pulling eyes, bonding inserts and struts for racking. Pre-cast neck and shaft extensions shall be provided as required to bring the cover to the finished elevation.
- All maintenance vaults shall be provisioned with Neenah Foundry #R-1751-C frame, with solid outer lid and gasketed inner lid with lockbar. Outer lid shall be permanently marked "Communications".
- Manholes for utilization with multiple conduit duct banks shall have a minimum interior size of 8'x10', Utility Vault Co #510-TA or equivalent. With prior approval from UITs, manholes for utilization with less than 4 conduits may be smaller, 4'x4' nominal exterior dimensions, Utility Vault Co. #444-LA or equivalent.
- Conduits shall enter vaults through single duct knockouts, with the space between the conduit and the knockout filled to form a watertight seal.

2.9.3 Handholes

- Handholes are intended for use as pull points only, and shall not be used as splice points without prior written permission from UITs Engineering.
- Handholes shall be polymer concrete, with H-20 traffic rated cover.
- Provide handholes with lockable, vandal resistant galvanized steel insert, as manufactured by McCain Inc. or equivalent.
- Joint use of handholes with electric or other utilities is not permitted.

Part 3 - Products

3.1 Materials List:

All items not specifically covered in these specifications must have the concurrence of the University UITs-Infrastructure Services Engineering Department before placement or implementation.

- 3.1.1 Approved Cat. 6 station cables are: Belden 3613, Berk-Tek LanMark1000, Superior Essex DataGain. Cable shall be plenum rated, with violet jacket.
- 3.1.2 Approved Cat. 5e cables (for use only in existing buildings with Cat. 5e or older legacy cabling): Belden 1213, BerkTek LANmark350, General Cable GenSpeed 5350. Cable shall be plenum rated, with orange jacket.
- 3.1.3 Approved outdoor station cables for below grade use are: Cat. 6 -Mohawk #M57622, Superior Essex BBD6; Cat. 5e -Mohawk #M58926, Superior Essex BBDe.

- 3.1.4 Multi-Pair Copper Riser Termination blocks: Cat. 5e, Panduit #P110B100R2 (rack mount), Panduit #P110BW series (wall mount for legacy applications only)
- 3.1.5 Connecting blocks: Cat.5e: Panduit P110CB4, P110CB5; Cat. 6: Panduit GPCB4
- 3.1.6 Patch panels for station cabling: angled modular patch panels, Panduit #CPPLA24WBLY (24 port), Panduit #CPPLA48WBLY (48 port) populated with CJ688TGVL jacks.
- 3.2.1 Telephone/Data outlets: Cat. 6: Panduit CF1064EI frame, with CMBEI blank modules and CJ688TGVL jacks. All Cat. 6 jacks shall be violet in color.
- 3.2.2 Telephone/Data outlets: Cat. 5e (for use only in existing buildings with Cat. 5e or older legacy jacks): Panduit CF1064EI frame with CMBEI blank modules and CJ5E88TGOR. All Cat. 5e jacks shall be orange in color.
- 3.2.3 Outlet cover plate: all cover plates shall be stainless steel, Pass & Seymour #SS8 (single gang), #SS82 (double gang).
- 3.2.4 Wall telephone outlet: Panduit, KWP6P stainless steel phone plate with Giga-TX style CAT 6 keystone jack module
- 3.2.5 Surface mount jack enclosure- use for "Blue Light" phone jacks, wireless access points: Panduit #CBX2.
- 3.2.6 Blank cover plate: Pass & Seymour #SS14 (single gang), #SS24 (double gang). NOTE: Blank telephone style cover plate shall not be used.

- 3.3.1 Fire Stop – high capacity sleeves shall be STI EZ-Path, 3M Quick Pass, Wiremold FlameStopper, or prior approved equivalent. Small cable penetration sleeves shall be STI EZ-Firestop or prior approved equivalent. Caulks and sealants shall be as manufactured by STI, 3M, Nelson, or approved equivalent, and listed for the intended application.
- 3.3.2 Cable shield connector: 3M Scotchlock #4460, 4460-S
- 3.3.3 Bonding & Ground cable/wire: Ground Wire - #6 AWG minimum, Bonding Cable - #6 AWG rated flexible braid with eyelets. Insulated ground wire shall have insulation that is green in color.
- 3.3.4 Splice case filling compound, re-enterable type: 3M 4442.
- 3.3.5 Heat Shrink Tubing: Highly Flame Resistant, semi rigid, polyvinylidene fluoride (Kynar).
- 3.3.6 Cable Ties: Plenum type where required by code – Panduit hook and loop type.
- 3.3.7 Cross connect wire: Cat. 5e, 2 pair, #24 AWG, solid, copper, REA color code, polyethylene or PVC insulation.

- 3.4.1 Fiber Optic enclosures: All associated hardware shall be provided, including ground clamp, labels, vertical troughs, horizontal troughs, connector panels, blank panels, etc.
- 3.4.2 Fiber Optic Connector: LC, fusible splice-on type, Corning FuseLite or AFL FuseConnect.
- 3.4.3 Rack mount optical fiber enclosures for riser cable applications shall Corning CCH series or Panduit FCE series, with loaded LC adapter panels. Adapter panels shall have 12 duplex adapters, with zirconia ceramic split sleeves, OM3/OM4 or OS2 rated for multimode and singlemode fiber respectively.
- 3.4.4 Optical fiber riser cable shall be Corning Cable Systems MIC series, Optical Cable Corp. DX series, or Commscope Premises Riser Distribution series.
- 3.4.5 Optical fiber outside plant cable installed in tunnels, duct banks, or aerial construction shall be gel free, Corning Cable Systems Altos Armor series.
- 3.4.6 Optical fiber building entrance cable shall be Corning Cable Systems FREEDM series, gel free with interlocking armor.

- 3.5.1 Surface raceway: Steel or aluminum only. Wiremold 2400 or approved equal is the minimum size acceptable; larger sizes may be required based on the size and number of cable and jacks to be accommodated.
- 3.5.2 "D" Rings: Lucent 13A (2 in.), 13B (4 in.), 13C (6 in.) Note: for use in telecom rooms for vertical cable management only.
- 3.5.3 Cable hangers: Erico/Caddy Cat Links "J" hangers.
- 3.5.4 Approved wire basket type cable trays are Cablofil EZTray and GS Metals Flextray.
- 3.5.5 Overhead cable tray for use in telecom rooms: Panduit Wyr-Grid, 12" minimum width, with 2" minimum height sidewalls provided at 12" intervals along the length of the tray. Provide intersection bend control radius fittings on all 90 degree and 'Tee' junctions.

- 3.6.1 Two post equipment racks: provide 7 ft. x 19" freestanding welded steel equipment rack, B-Line #SB-506-084-U-TG or approved equal.

- 3.6.2 Vertical cable managers: freestanding equipment racks shall be provided with 7' high, double-sided cable managers 6" or 10" as indicated on the drawings, Chatsworth MCS Series, or approved equal.
- 3.6.3 Horizontal cable managers shall be provided as shown on the drawings. High capacity cable managers shall be Panduit #NCMHAEF4. Standard size cable managers shall be Panduit #NCMHF1. Small cable managers shall be Panduit #NCMHF1.
- 3.6.4 Blank filler plates for equipment racks shall be Panduit #CPAF1BLY, provided one per freestanding equipment rack, aligned with MCS Series vertical cable manager hinges as indicated on the drawings.
- 3.6.5 Four post equipment racks shall be 7 ft. high, 19" EIA width, 29" depth, Chatsworth #50120-X03.
- 3.6.6 Equipment rack grounding strips shall be Panduit #RGS134-1Y. ESD ports shall be Panduit #RGESD2-1, with #RGE SDWS wrist strap.
- 3.6.7 Protectors for multi-pair entrance cable shall have 110-in and 110-out connectors, and unless otherwise noted on the construction documents, shall be rack mounted, Porta Systems 19050-110-110. Protector modules shall be 4B1EW type.
- 3.6.8 Modular protectors for station cables (blue light phones, exterior cameras, etc.) shall be ITWLinx MCO4100 for voice service, and ITWLinx Cat6LAN for data service.

Part 4 - Acceptance Testing

- 4.1 End-to-end testing of all cable pairs, optical fiber strands, and coax cables shall be performed after completion of installation and termination. UTP Category 6 station wiring shall be in compliance with the EIA/TIA 568C standard. Cat. 6 systems shall be tested to Level III accuracy. Labels shall be applied at or before the time acceptance testing is performed.
- 4.2 Cable testing shall be performed with the terminating hardware at both ends inserted into the final patch panel, enclosure, or outlet position. For example, testing of fiber strands from the back of the fiber enclosure prior to inserting the connector into the adapter panel mounted in its final resting place is not acceptable.
- 4.3 Cable testing shall be performed using Fluke DTX or Versiv series test equipment.
- 4.4 Copper station cable tests shall be "Permanent Link" tests, performed with the appropriate test adapters/cords. "Basic Link" and "Channel" tests are not acceptable.
- 4.5 End-to-end attenuation testing of each optical fiber strand shall be made using an optical power meter and optical light source. Multimode fibers shall be tested at 850 and 1300nm. Singlemode fibers shall be tested at 1310 and 1550nm. Attenuation tests shall be performed in both directions.
- 4.6 UITS-Infrastructure Services Engineering must approve test documentation. Documentation shall be submitted in Fluke LinkWare Database electronic format.
- 4.7 Test result documentation shall indicate the final cable/outlet number assigned to each item tested, as well as identify the project and the telecommunications room serving each item tested. The test result submittal shall be organized by telecommunications room, with the test results in sequential order based on jack id. Test results that are incomplete or that are not organized in sequential order will not be accepted.

Part 5 – Demolition

- 5.1 All abandoned telecommunications cables within a project's boundaries shall be completely removed back to the termination block, including multi-pair cabling, coaxial Ethernet cabling, and station cabling.
- 5.2 Tele/data outlets shown on demolition drawings to be removed shall be removed completely including outlet and wiring to the originating IDF termination point. Termination labels shall be revised to reflect all changes.

**TELECOMMUNICATIONS RISER
NEW CONSTRUCTION**

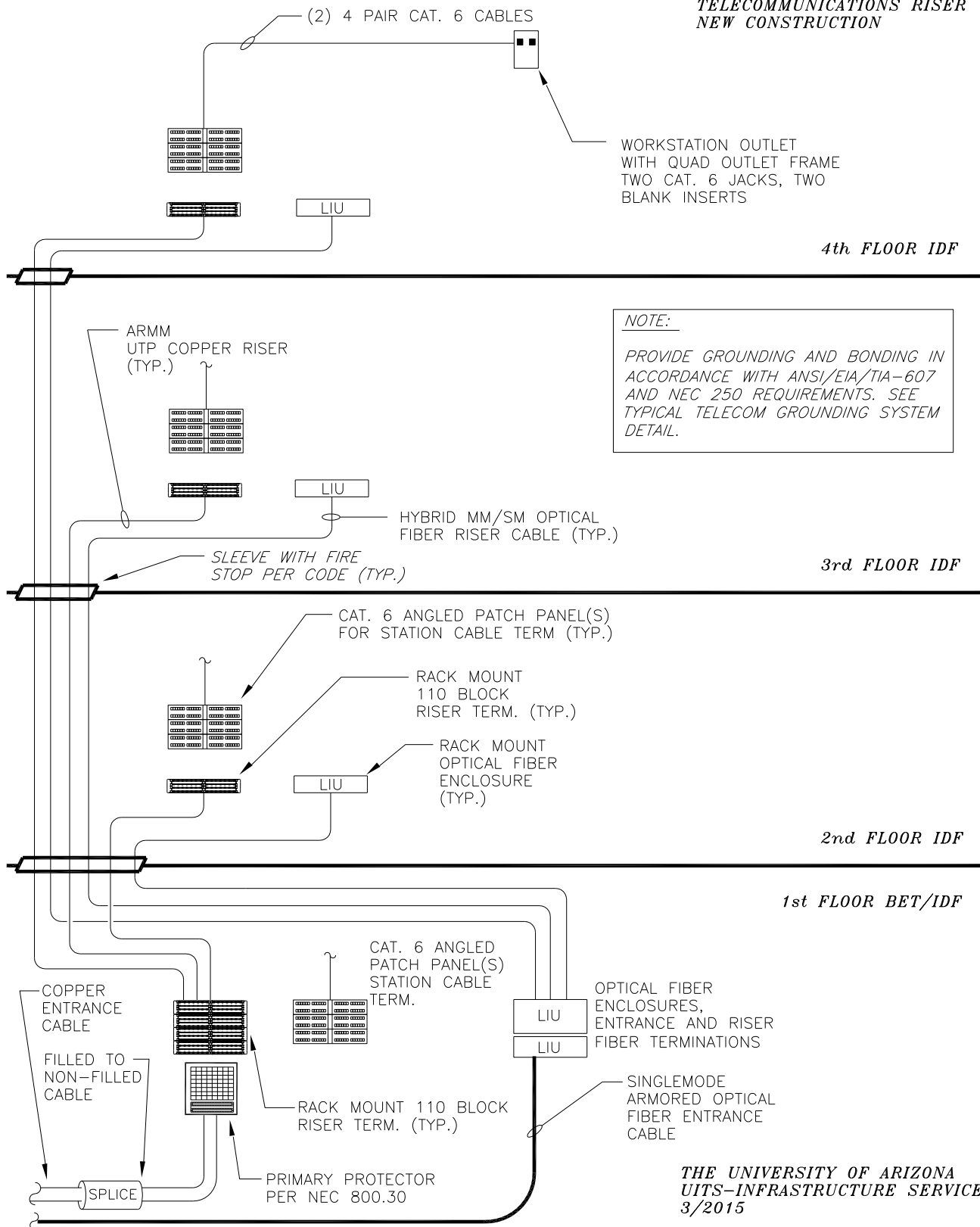

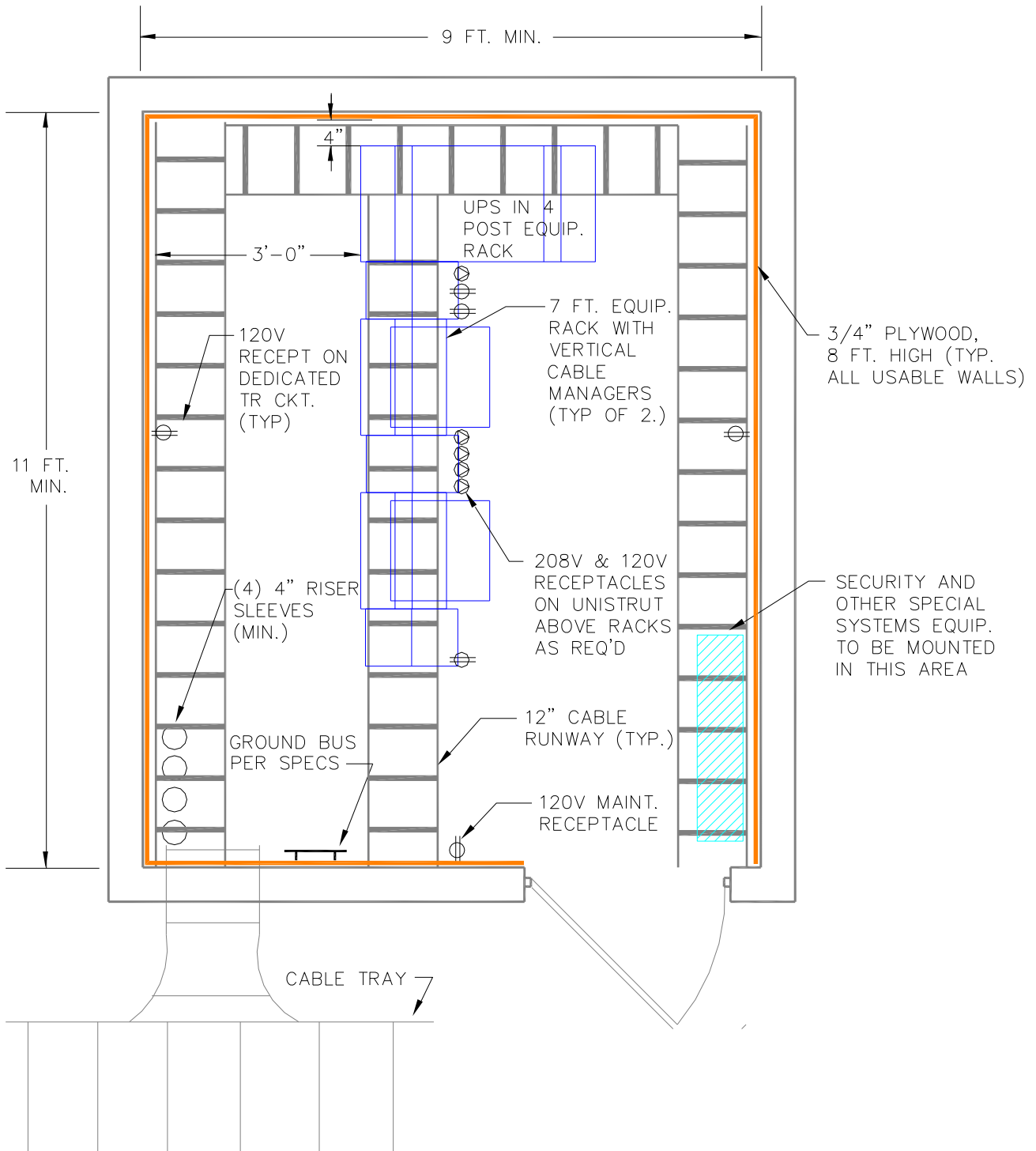

TYPICAL TELECOMMUNICATIONS ROOM

TELECOMMUNICATIONS GROUNDING SYSTEM

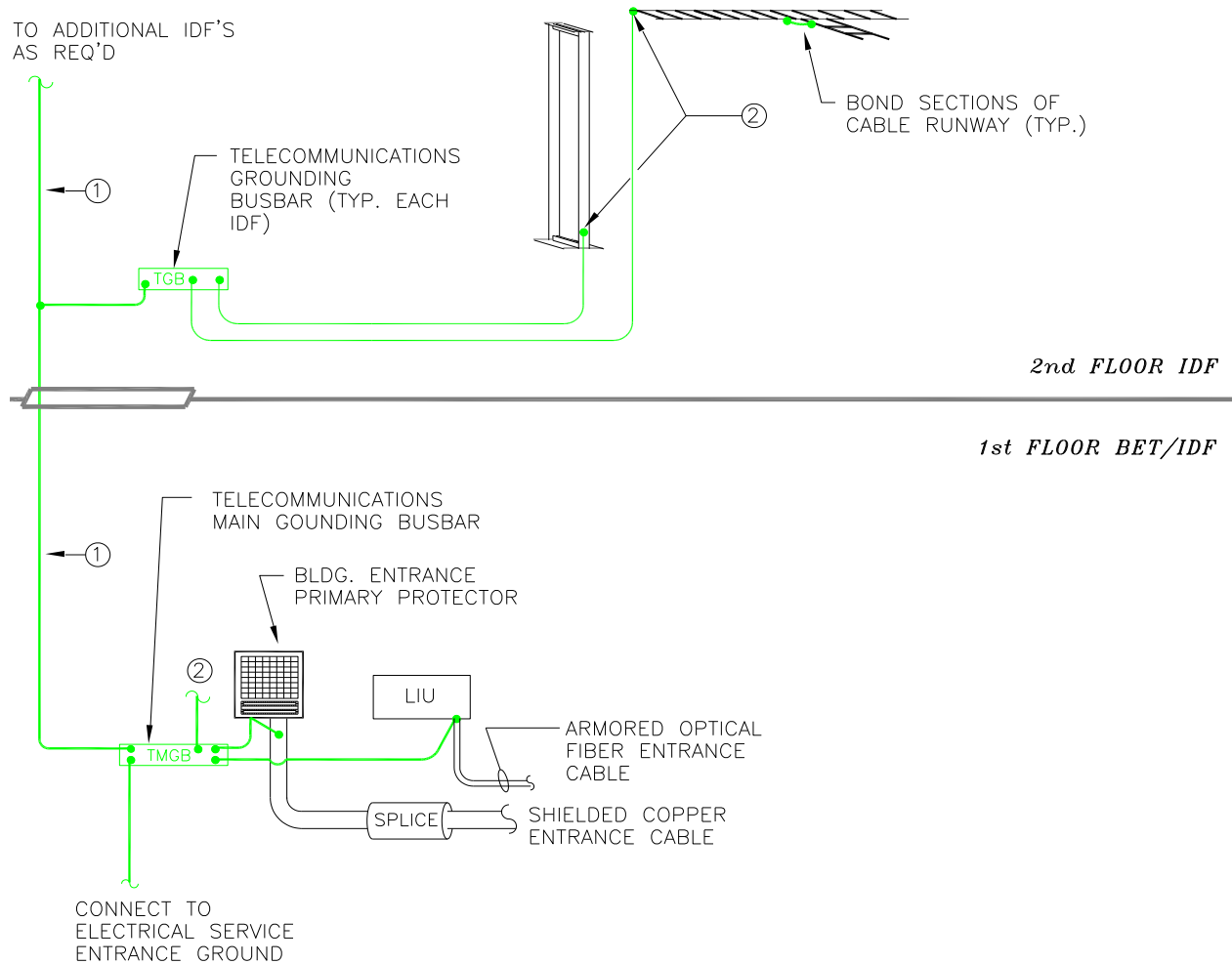

○ KEYNOTES

- ① TELECOMMUNICATIONS BONDING BACKBONE. SIZE PER ANSI J-STD-607A; #4 AWG MINIMUM.
- ② BOND TO EQUIPMENT RACKS, CABLE RUNWAY, CABLE TRAY, SHIELDED CABLE, ETC. #6 AWG MINIMUM, TYP. OF ALL IDF'S AND BET

NOTE:

GROUNDING AND BONDING SHALL BE IN ACCORDANCE WITH ANSI/EIA/TIA-607 AND NEC 250 REQUIREMENTS.

THE UNIVERSITY OF ARIZONA
UITS-INFRASTRUCTURE SERVICES
8/2009

SECTION 16720 – FIRE ALARM and MASS NOTIFICATION SYSTEMS

PART 1 - GENERAL

1.1 WORK INCLUDED

- A. The work covered by this section of the specifications includes the furnishing of all labor, equipment, materials, and performance of all operations in connection with the installation of the Fire Alarm Systems, Clean Agent Systems, Hood Suppression Systems and Mass Notification Systems as shown on the drawings and as herein specified.
- B. The work covered by this section of the specifications is to be coordinated with the related work as specified elsewhere under the project specifications.
- C. The intent of this project is to provide a complete networked fire alarm and mass notification system for this building.

1.2 RELATED WORK

- A. The drawings, general requirements, conditions of the contract, including General and Supplementary Conditions and Division 1 Specification Sections, apply to this section.
- B. The work described in this section has related work with:
 - Section _____ Electrical General Provisions
 - Section _____ Identification
 - Section _____ Electrical Demolition
 - Section _____ Conduit Systems
 - Section _____ Wire and Cable
 - Section _____ Grounding

1.3 FIRE ALARM SYSTEM DESCRIPTION

- A. Furnish a complete Audio Fire Alarm System as described herein and as shown on the plans; wire, connect, and leave in first class operating condition. Include a Fire Alarm Control Panel, manual pull stations, automatic fire detectors, speakers, clear and amber strobes, combination speaker/strobes, and remote control devices. Use closed loop initiating device circuits with individual zone supervision, individual indicating appliance circuit supervision, and incoming and standby power supervision. Provide Style D initiating circuits, Style Z signaling circuits, Style 6 communications circuits, all wiring, connections to devices, outlet boxes, junction boxes, and all other necessary material for a complete operating system.
- B. Allow for loading or editing special instructions and operating sequences in the Fire Alarm Control Panel as required. Provide a system capable of on site programming to accommodate and facilitate expansion, building parameter changes or changes as required by the owner, authorities having jurisdiction and code requirements. Provide storage for all fire alarm system software operations in a non-volatile, programmable memory within the Fire Alarm Control Panel. Loss of primary and secondary power will not erase the instructions stored in memory.
- C. Provide final as built in .dxf file format, sized and scaled for used on 4190 TSWs.
- D. Incorporate in the resident software programming of the system the full ability for selective input/output control functions based on ANDing, ORing, NOTing, timing and special coded operations.
- E. Provide a system that communicates with all initiating and control devices individually on a multiple addressable peripheral network (MAPNET). Annunciate all initiating and control devices individually at the Fire Alarm Control Panel. Include the following annunciation conditions for each point:
 - Alarm

- Trouble
 - Open
 - Short
 - Ground
 - Device Fail or Incorrect Device
- F. Provide a system capable of individually disabling or enabling all addressable devices. Field configure all devices to allow for the addition of devices on a circuit after the initial installation.
- G. Provide a system capable of multi-dropping up to 250 addressable devices from a single pair of wires using IDNET communications only.
- H. Provide a system capable of having software programming modified and initiating or control devices added or deleted in the field. Systems that require factory reprogramming to add or delete devices are unacceptable.
- I. Provide all necessary software on disk or cd along with any required software keys to allow the University to program changes, additions, removals or re-labels. This includes the programming software for the FACP's and the TSW's.
- J. Provide a system with a completely digital, poll/response protocol communications format. System to use parity data bit error checking routines for address codes and check sum routines for the data transmission protocol to achieve a high degree of communication reliability. Systems that do not utilize full digital transmission protocol (i.e. that may use time pulse width methods to transmit data etc.) are not acceptable.
- K. Provide a system where each addressable device is uniquely identified by an address code entered on the base of each device at time of installation. The use of jumpers to set address will not be acceptable due to the potential of vibration and poor contact.
- L. Provide a system capable of supporting up to 10,000 feet wire length for each class "A" initiation circuit loop.
- M. **MINIMUM DETECTION REQUIREMENTS**
1. Provide automatic smoke detection in all hallways, common areas, electric rooms, telecommunication rooms, and along all paths of egress. Beam smoke detectors and or fire detection cameras may be used in place of spot type smoke detectors.
 2. Provide heat detection in all mechanical and janitor rooms. Fire detection cameras may be used in place of spot type heat detectors.
 3. Provide supply side duct smoke detectors on all air handlers and fan coils over 1999cfm, also provide return side duct smoke detectors on all air handlers and fan coils over 14,999cfm.
 4. Provide manual double action pull stations protected by a sounder cover at all floor level exits and all ground level exits.
 5. Provide monitoring of all fire sprinkler flow switches, valve tamper switches, air bleeders, fire pump status points, and chemical injection systems.
- N. **ALARM SEQUENCE**
1. The system alarm operation subsequent to the alarm activation of any manual station, automatic detection device, or sprinkler flow switch is to be as follows:
 - a. Sound a ANSI 3.14 compliant fire alarm signal on all audible alarm indicating appliances until silenced by the alarm silence button at the Fire Alarm Control Pane.
 - b. Flash all strobes synchronized and continuously on all visual alarm indicating appliances until system is reset.
 - c. Release all doors normally held open by door control devices to include all electronically controlled access doors.
 - d. Activate/deactivate mechanical controls on the air handling systems per specifications of the owner and in accordance with the State of Arizona Fire Code and the University of Arizona Fire Code. Sequentially restart air handling units upon system reset to reduce electrical demand.
 - e. Display an alarm condition on the Fire Alarm Control Panel display per 2.3.A of these specifications. Flash the alarm LED on the Fire Alarm Control Panel until the alarm has been acknowledged at the Fire Alarm Control Panel. Latch the alarm LED on upon

- alarm acknowledgement. After the alarm has been acknowledged, flash the alarm LED on the Fire Alarm Control Panel again upon receipt of a subsequent alarm from another device/zone. Display the new alarm information on the Fire Alarm Control Panel display.
- f. Provide a pulsing alarm tone that will occur within the Fire Alarm Control Panel until acknowledged. Provide a pulsing alarm tone that is capable of being disabled or removed if so specified by the owner.
2. All elevator connections shall be per schematic diagram 16720-D3 and block diagram both located at end of this section, below is a sequence of operations for the elevator connections;
 - a. The alarm activation of any elevator lobby smoke detector will cause the elevator cabs to be recalled according to the following sequence:
 1. Recall the elevator cabs to the main egress floor (as indicated by the owner and authority having jurisdiction) upon the activation of an elevator lobby smoke detector on any floor other than the main level of egress.
 2. Recall the elevator cabs to the predetermined (as indicated by the owner and authority having jurisdiction) alternate level of egress upon the activation of the elevator lobby smoke detector on the main egress level.
 - b. The alarm activation of any elevator machine room or hoist way heat detector will cause the shunt trip control to be activated.
 - c. The loss of shunt trip control power will cause a supervisory condition to be displayed on the Fire Alarm Control Panel.
 - d. The alarm activation of any elevator machine room or hoist way smoke detector will cause the fireman's hat in the cab to flash.
 3. Provide a manual evacuation switch to operate the systems alarm indicating appliances only, leaving other control circuits in their normal state.
 4. Override the automatic alarm functions either selectively or throughout the system upon activation of auxiliary bypass keys or bypass groups.
 5. Immediately display alarm and trouble conditions on the Fire Alarm Control Panel front alphanumeric display. If more alarms or troubles are in the system the operator may scroll to display new alarms.
 6. Provide a system with a list key that will allow the operator to display all alarms, troubles, and supervisory service conditions with the time of occurrence. This shall allow for the determination of not only the most recent alarm but also may indicate the path that the fire is taking.
 7. All doors normally held open by door control devices shall release upon AC power failure.
 8. Generator Controls and Monitoring. (This applies to each generator installed).
 - a. Provide an IAM connected to the generator controls to monitor if the generator is running.
 - b. Provide an IAM connected to the generator controls to monitor if the generator system has a fault.
 - c. Provide an IAM connected to the Automatic Transfer Switch (ATS) to monitor if the ATS is connected to the emergency source.
- O. SUPERVISION
1. Provide a system with Class 'A' (Style 'D') independently supervised initiating circuits so that a fault in any one zone/device does not affect any other zone/device and so that an alarm activation of any initiation circuit does not prevent the subsequent alarm operation of any other initiation circuit.
 2. Provide sprinkler supervisory initiation device circuits for connection of all sprinkler valve tamper switches to perform the Supervisory Service Operation. Wiring methods which affect any fire alarm initiation circuits to perform this function will be deemed unacceptable; i.e.: sprinkler and standpipe tamper switches (N/C contacts) shall NOT be connected to circuits with fire alarm initiation devices (N/O contacts). Label this independent initiation circuit as Supervisory Service and provide differentiation between tamper switch activation and wiring faults.

3. Provide independently supervised and independently fused indicating appliance circuits for horns and strobes. Disarrangement conditions of any of these circuits will not affect the operation of other circuits.
4. Supervise all auxiliary manual controls so that all switches must be returned to the normal automatic position to clear system trouble.
5. Include a discrete Fire Alarm Control Panel readout for each independently supervised circuit to indicate disarrangement conditions per circuit.
6. Supervise the incoming power to the system so that any power failure must be audibly and visually indicated at the Fire Alarm Control Panel. A green "power on" LED shall be displayed continuously while incoming power is present.
7. Supervise the system batteries so that a low battery condition or disconnection of the battery shall be audibly and visually indicated at the Fire Alarm Control Panel.
8. Supervise any system expansion modules for module placement. Should a module become disconnected from the controls, the system trouble indicator must illuminate and audible trouble signal must sound.
9. Provide independent supervision for opens of the air handling on/off/auto switch control output wiring. Provide a discrete trouble panel readout per output circuit for indication. Provide indication of a common ground trouble on the Fire Alarm Control Panel in the presence of a ground condition of the air handling control output wiring.
10. Supervise all slave module LEDs for burnout or disarrangement. Should a problem occur, the Fire Alarm Control Panel shall display the module and the LED location numbers to facilitate location of that LED.

P. POWER REQUIREMENTS

1. Provide each Fire Alarm Control Panel, Fire Alarm Miniplex, and Fire Alarm NAC Extender with an individual 120VAC 20AMP power circuit via a dedicated disconnect means that includes over-current protection. Ensure that the panel location, panel identifier, and circuit number is clearly identified at each Fire Alarm Control Panel, Fire Alarm Miniplex, and Fire Alarm NAC Extender. Ensure that the electric panel schedules are labeled with "FIRE ALARM" on all circuits supplying fire alarm equipment. Ensure each circuit breaker supplying fire alarm equipment is locked in the "ON" position with a lock dog.
2. Provide the system with sufficient battery capacity to operate the entire system upon loss of normal 120 VAC power in a normal supervisory mode for a period of twenty-four (24) hours with 15 minutes of alarm operation at the end of this period. Automatically transfer the system to the standby batteries upon primary power failure. All battery charging and recharging operations shall be automatic.
3. Provide 24VDC from the Fire Alarm Control Panel to all circuits requiring system operating power. Individually fuse all these circuits at the Fire Alarm Control Panel.

1.4 CLEAN AGENT SYSTEM DESCRIPTION

A. SYSTEM REQUIREMENTS

1. Provide approved Ecaro or Intergen based suppression equipment that reports to the existing building fire alarm system.
2. Acceptable clean agent control panel manufactures and models are the SimplexGrinnell 4000 series and the Fike Cheetah
3. All equipment must directly control any related systems for the protected space such as Emergency Power Off, Air Handler Shutdown, Damper Controls, Door Releases, or similar.

1.5 HOOD SUPPRESSION SYSTEM DESCRIPTION

A. SYSTEM REQUIREMENTS

1. Provide approved hood suppression equipment that reports to the existing building fire alarm system.
2. All equipment must directly control any related systems for the protected space such as Emergency Power Off, Air Handler Shutdown, Damper Controls, Door Releases, or similar.

1.6 MASS NOTIFICATION SYSTEM DESCRIPTION

A. SYSTEM REQUIREMENTS

1. Provide equipment that is compatible with the existing camps ATI system.
2. All equipment must be interconnected to the ATI Master Command and Control Station (CS) for the entire Emergency Communication System (ECS) located in the UofA FM Fire Safety office.

1.7 QUALITY ASSURANCE

- A. Provide each and all items of the Fire Alarm System that are the products of a SINGLE fire alarm system manufacturer, unless otherwise required by this specification, under the appropriate category by Underwriters' Laboratories, Inc. (U.L.), and bearing the "UL" label. Provide control equipment that is all listed under UL category UOJZ as a single control unit. Partial listing is NOT be acceptable.
- B. Provide each and all components of the Fire Alarm System that are the products of a single manufacturer (independent dealers and/or distributors will NOT be considered) who has engaged in the production of this type of equipment (software driven) for at least 10 years, and has a fully equipped service organization within fifty (50) miles of this installation.
- C. Furnish fire alarm equipment installation supervision from a factory trained and certified manufacturer's representative (independent dealers and/or distributors will NOT be considered) who has been engaged in the installation of this type of equipment (software driven) for at least ten (10) years.
- D. Provide system controls that are UL listed for Power Limited Applications per NEC 760, in addition to the UL-UOJZ requirement mentioned above. Mark all circuits in accordance with 1996 NEC article 760-23 and these specifications.
- E. Provide transient protection devices on all control equipment to comply with UL864 requirements.
- F. Transient protection must be provided for each circuit, where fire alarm circuits leave the building. Provide devices that are UL listed under Standard 497B (Isolated Loop Circuit Protectors).

1.8 REFERENCES

- A. Install the complete system in conformance with the applicable sections of the Arizona State Fire Code and referenced codes and standards, University of Arizona Fire Code and referenced codes and standards and other standards listed in Section 16010.
- B. Install and configure the entire fire alarm system and integrated system operations in conformance with the State of Arizona Fire Code and the University of Arizona Fire Code.

1.9 SUBMITTALS

- A. Submit complete fire alarm layout drawings and equipment cut sheets prior to beginning any construction work on the Fire Alarm System. Depict on the layout drawings all equipment and field devices, routing of wiring, connection information, address identification number for each device, etc.
- B. Submit fire alarm shop drawings to the University of Arizona Fire Marshal and receive approval prior to beginning any construction work on the Fire Alarm System.

1.10 DELIVERY, STORAGE, AND HANDLING

- A. Store all fire alarm and mass notification equipment (Fire Alarm Control Panel, all peripheral devices, equipment enclosures, etc.) in an environmentally controlled location until required on project site. Store all fire alarm equipment at the project site in an environmentally controlled location until installed.

1.11 WARRANTY

- A. Provide a warranty for the completed fire alarm system wiring and equipment to be free from inherent mechanical, electrical, and software programming defects for a period of two (2) years from the date of the completed and certified test by the Authority Having Jurisdiction.

PART 2 - PRODUCTS

2.1 ACCEPTABLE MANUFACTURERS

- A. Provide fire alarm panels and fire alarm peripheral devices that are all the standard product of a single manufacturer, displaying the manufacturer's name on each component. Provide a fire alarm system that is manufactured by SimplexGrinnell, Inc. The catalog numbers specified under this section are those of SimplexGrinnell, Inc. and constitute the type, product quality, material, and desired operating features.
- B. Provide mass notification equipment that is all the standard product of a single manufacture, displaying the manufacturer's name on each component. Provide a mass notification system that is manufactured

by ATI Systems, Inc. The mass notification equipment catalog numbers specified under this section are those of ATI Systems, Inc. and constitute the type, product quality, material, and desired operating features.

2.2 MATERIALS

A. WIRING

1. The following wiring requirements apply in addition to other wiring requirements found elsewhere in these specifications.
2. Use only wiring type approved by the fire alarm equipment manufacturer.
3. Color Coding for fire alarm wiring is listed below. Use solid color compound or solid color coating on all conductors. Identify with colored tape wire sizes for which colored insulation is not available.

<u>Circuit Type</u>	<u>Color Code</u>	<u>To What</u>	<u>Wire Size</u>
Agent Signal Wiring A/Vs & V/Os	Red / Black	Signal Module	#14
Agent Low Tank Pressure Switch	Orange / Brown	IAM	#14
Agent Tank Discharge Switch	Orange / Brown	IAM	#14
Agent Pull Station	Yellow / Blue	IAM	#14
Agent Abort Switch	Yellow / Blue	IAM	#14
Agent Bell	Red / Black	Signal ZAM	#14
Pre-Action Low Air Pressure	Orange / Brown	IAM	#14
Pre-Action Discharge Switch	Orange / Brown	IAM	#14
Solenoid Wiring	Red / Black	Signal ZAM	#14
Solenoid Disconnect Switch	Red / Black	Coil Module	#14
Water Flow Bell	Red / Black	Signal ZAM	#14
Water Flow Switch	Orange / Brown	IAM	#14
Valve Tamper Switch	Orange / Brown	IAM	#14
Smoke Detector	Mapnet	FACP	#18 T/S/P
Beam Detector	Yel / Blu / Wht / Vio	IAM	#14
Heat Detector	Mapnet	FACP	#18 T/S/P
Flame Detector	Yel / Blu / Wht / Vio	IAM	#14
Hood Suppression Systems	Yellow / Blue	IAM	#14
Cable Smoke Detectors (VESDA)	Yel / Blu / Wht / Vio	IAM	#14
Pull Station	Mapnet	FACP	#18 T/S/P
Duct Detector	Mapnet / Wht / Vio	FACP	#18 T/S/P - #14
ZAM (All types)	Mapnet / Wht / Vio	FACP	#18 T/S/P - #14
IAM	Mapnet	FACP	#18 T/S/P
Relays	White / Violet	Control Point	#14
120VAC Door Holders	White / Phase Color	Control Point	#12
120VAC Dampers	White / Phase Color	Control Point	#12
AHU Contactor / MCC Shutdown	Phase Color / Sw Leg	Relay	#12
AHU VFD Shutdown	Red / Red	Relay	#14 or #12
Audio Visual	Red / Black	Sync Module	#14 T/P
Visual Only	Red / Black	Sync Module	#14 T/P
Sync Module	Red / Black	Signal Circuit	#14
Ground / Bond	Green	Grounds/Bonds	#14

Mapnet is defined as Power Limited or Non-Power Limited Twisted Shielded #18 Pair Cable.

Phase Color is defined as the primary phase color used to power the controlled device.

Sw Leg is defined as the switch leg color used to power the controlled device.

2.3 EQUIPMENT

A. FIRE ALARM CONTROL PANEL

Where shown on the plans, provide and install the Fire Alarm Control Panel called for in these specifications. Provide a Fire Alarm Control Panel compatible as a pier with a Simplex 4120 pier to pier reporting network, this includes total exchange of all analog, digital, pseudo, and control data.

1. Simplex 4100ES Network Control Panel:

- a. This system shall be used for all fire alarm speaker installations.
 - b. This system shall be used for all fire alarm fire phone installations.
 - c. This system shall be used for all addressable detection installations.
 - d. Panel shall include one, (1,) 4120 Network Communications card with two, (2,) RS-485 Hardwire Media Cards.
 - e. If fire alarm system is not directly connected to the campus reporting system, panel shall include two, (2,) Network TCP/IP bridge cards with four, (4,) RS-485 Hardwire Media Cards.
 - f. Panel shall include three, (3,) Ethernet jacks connected per section 16700. Only one, (1,) Ethernet jack is required if the fire alarm system is directly connected to the campus reporting system.
2. Additional Control Panel Equipment and Capacities:
- a. Fire alarm panels shall be provided with twenty-five, (25,) percent spare capacity installed on the following components:
 - i. Audio circuits.
 - ii. Visual circuits.
 - iii. Speaker circuits.
 - iv. Fire Phone circuits.
 - v. Addressable Detection points.
 - vi. Hard-wire Detection points.
 - vii. Auxiliary Control circuits.
 - viii. Graphic I/O points.
 - b. Power supplies:
 - i. Shall be sized as necessary to provide all the power required in section 16720-2.3, A, 2.) with an additional twenty-five, (25,) percent spare capacity.
 - ii. And shall provide two, (2,) amps of power for each and every installed Notification Appliance Circuit, Auxiliary Control Circuit, Auxiliary Relay Zone Addressable Module, and Signal Zone Addressable Module.
 - c. Batteries:
 - i. Shall be sized as to provide twenty-four, (24,) hours of standby operation for the load handled by the power supplies.
 - ii. Shall be sized as to provide fifteen (15) minutes of alarm as required in 16720 1.3, O, 2 for the load handled by the power supplies after twenty-four, (24,) hours of standby operation.
 - iii. The only acceptable batteries are listed here by manufacturer, amperage and voltage.
 - 1. Eagle Pitcher, Simplex, Interstate
 - a. 7A 12VDC.
 - b. 12A 12VDC.
 - c. 18A 12VDC.
 - d. 33A 12VDC Square case or Long case.
 - e. 55A 6VDC.
 - f. 58A 6VDC.
 - g. 58A 12VDC
 - 2. Sonnenschein, Simplex, Interstate
 - a. 115A 12VDC.
3. Auxiliary Bypass Keys
 Provide five (5) auxiliary bypass keys on the Fire Alarm Control Panel. Activation of these keys to be password protected. When activated, the normal alarm sequence operations of the programmed devices/control functions will not occur. Upon activation of these keys, a trouble condition will be present on the Fire Alarm Control Panel. Indicate on the Fire Alarm Control Panel one (1) trouble condition for each signal circuit/type of device/control function that is effected by the bypass.
 Program the keys to accommodate bypassing the following devices/control functions (in order, from top to bottom):

- Air Handler Unit Shut Down and Door Holder Release
 - Sprinkler System Water Flow Switches
 - Audible and Visual Signaling Devices
 - Duct Smoke Detectors
 - Elevator Recall
4. Device Bypass Groups
 Provide the Fire Alarm Control Panel with the capability of supporting separate lists of device groups whereby particular groups of devices may be bypassed and the rest of the system will remain active and operate as programmed per normal system operation. Program the groups to operate upon activation of a single point, negating the need to deactivate/reactive each individual device in the group. Provide the following groups of devices:
- Smoke detectors by floor, in groups as designated by the Owner.
- B. FIRE ALARM NON-ADDRESSABLE PERIPHERAL DEVICES
1. Speaker Visual – 75 candela units – Model #4903-9357
 Provide polarized fire alarm speaker/strobe that operates with 25VDC. Provide separate wire leads for in/out wiring for each leg of the associated signal (speaker) circuit.
 2. Sprinkler System Water flow switches - Equipment from Division 15 or existing
 Monitor automatic sprinkler system water flow switches with Individual Adaptor Modules (IAMs). Provide water flow switches consisting of a cast aluminum pipe saddle housing an electromechanical device to which is attached a corrosion-free, flexible, low-density polyethylene paddle. The paddle conforms to the inside diameter of the sprinkler pipe and senses all water movements. To prevent false alarms, incorporate an adjustable time delay mechanism in the flow switch between the paddle-operated stem and the alarm initiating contacts. Provide a tapped 1/2" conduit connection. Provide a flow switch with a UL listing for the intended purpose.
 3. Sprinkler System Valve Tamper Switches - Equipment from Division 15 or existing
 Monitor automatic sprinkler system valve tamper switches with Individual Adaptor Modules (IAMs). Provide valve tamper switches consisting of an acid treated, cast aluminum housing with nickel plated parts to resist corrosion. Supervise the removal of the switch housing cover. Provide the switch with either one or two sets of S.P/D.T. micro switches as required. Provide a switch with a UL listing for its intended purpose.
 4. Door Holders - 120VAC - Model #DH24120RPC (Flush), #DH24120SPC (Surface) or Model #DH24120FPC (Semi-flush)
 Control door holders with Zone Adaptor Modules (ZAMs). Provide magnetic door holders with an approximate holding force of 35 lbs. Provide the door portion with a stainless steel pivotal mounted armature with shock absorbing nylon bearing. Provide a door holder unit capable of being either surface, flush, semi-flush or floor mounted as required. Provide door holders with a UL listing for their intended purpose.
 5. Photoelectric Projected Beam Detectors - Transmitter/Receiver Set - Model #D296
 Provide photoelectric, projected beam detectors capable of being monitored by Individual Adaptor Modules (IAMs) or Zone Adaptor Modules (ZAMs). Provide photoelectric projected beam detectors with the UL #268 listing. Provide separate transmitters/receivers capable of long range coverage of up to 328 ft (100M), and have seven (7) sensitivity settings. Incorporate automatic compensation for lens contamination. Include a normal status indicator (Green Pulsing LED), an alarm indicator (Red LED) and a trouble indicator (Amber LED) on the detector. Provide dedicated, resettable, operating power for the detectors from the Fire Alarm Control Panel. Provide 24VDC operating voltage (Nominal).
 6. Fire Alarm Auxiliary Relay - Part #2088-9007
 Provide one or two single pole, double throw relay switches for loads up to 120VAC in its own enclosure. Provide a separate 24 VDC output relay with 10A, 120VAC rated contacts with a 7A in-line fuse for control of each type of equipment indicated to have relays. Provide power to this relay from the 24VDC power for the fire alarm device that controls the relay. Control this relay from duct detector auxiliary contacts or ZAM contacts.

Provide relays for interfacing the fire alarm system with the following equipment:

- air handling system motor control centers
- door holder circuits
- shunt trip circuits

Route circuits from controlled equipment and fire alarm device (duct detector or ZAM) into relay box. Orient relay so any 120VAC (or greater) circuit does not cross the 24VDC fire alarm circuit inside the relay box. Route ONLY 24VDC into the fire alarm device boxes.

C. FIRE ALARM ADDRESSABLE DEVICE TYPES

1. General - The system Fire Alarm Control Panel, over its two wire multi-drop channel, must be capable of communicating with the types of addressable devices specified below.
2. Addressable Sensor Bases - Model #4098-9792
Provide sensor bases containing an integral LED that will flash each time it is scanned by the Fire Alarm Control Panel (once every 4 seconds). Turn the sensor base LED "ON" when the Fire Alarm Control Panel determines that a sensor is in the alarm or a trouble condition. Sensor bases which do not provide a visible indication of an abnormal condition at the sensor location are not acceptable.
3. TrueAlarm Smoke Sensors - Model #4098-9714
Provide photoelectric type, addressable smoke sensors that communicate actual smoke chamber values to the system Fire Alarm Control Panel. Provide solid state, photoelectric type sensors containing no radioactive material. Use a pulsed infrared LED light source and be sealed against rear air flow entry for sensor operation.
Interrupt the supervisory current of the fire alarm detection loop upon removal of the detector head and cause a trouble signal at the Fire Alarm Control Panel. Provide a plug-in sensor unit which mounts to a twist-lock base.
Provide sensors with a UL #268 listing and documented as compatible with the control equipment to which they are connected. Provide sensors listed for both ceiling and wall mount applications. Provide sensors containing a magnetically actuated test switch to provide for easy alarm testing at the sensor location.
Scan each sensor by the Fire Alarm Control Panel for its type identification to prevent inadvertent substitution of another sensor type. Permit continued operation of the Fire Alarm Control Panel but initiate a "WRONG DEVICE" trouble condition until the proper type is installed or the programmed sensor type is changed.
Provide sensors with electronics immune to false alarms caused by EMI and RFI.
Provide sensors that fit into a base that is common with both the heat detector and photoelectric type detector and non-addressable bases capable of being monitored by an Zone Adaptor Module (ZAM) or Individual Addressable Module (IAM). Provide sensors compatible with other addressable detectors, addressable manual stations, and addressable Zone Adaptor Modules on the same circuit.
There will be no limit to the number of detectors, stations, or Zone Adaptor Modules, which may be activated or "in alarm" simultaneously.
4. Addressable Thermal Detector Head - Model #4098-9733
Provide UL listed, combination rate-of-rise and fixed temperature (135 F) type, automatically restorable thermal sensing heads.
Interrupt the supervisory current of the fire alarm detection loop upon removal of the heat sensor head and cause a trouble signal at the Fire Alarm Control Panel.
Provide a plug-in heat sensor unit which mounts to a twist-lock base. Provide sensors listed for both ceiling and wall mount applications.
Provide heat sensor units with a UL #268 listing and documented as compatible with the control equipment to which they are connected.
Scan each sensor by the Fire Alarm Control Panel for its type identification to prevent inadvertent substitution of another sensor type. Permit continued operation of the Fire Alarm Control Panel but initiate a "WRONG DEVICE" trouble condition until the proper type is installed or the programmed sensor type is changed.
Provide sensors with electronics immune to false alarms caused by EMI and RFI.
5. Addressable Pull Stations - Model #4099-9003

Provide double action, push-pull type, addressable pull stations containing electronics that communicate the station's status (alarm, normal) to the Fire Alarm Control Panel over two wires which also provide power to the pull station. Set the address for the device on the station itself. Provide pull stations manufactured from high impact red Lexan with raised lettering painted white with a UL listing for the devices intended purpose.

Provide pull stations with a "front" that is hinged to a back plate assembly that will mechanically latch upon operation and remain so until manually reset by opening with a key common to all pull stations. Provide pull stations with the Simplex Series "B" key locksets. Stations which use allen wrenches or special tools to reset are NOT acceptable. Provide an addressable pull station capable of field programming its "address" location on an addressable signaling line circuit.

There will be no limit to the number of stations which may be activated or "in alarm" simultaneously.

6. Addressable Photoelectric Duct Detector - Model #4098-9756 (uses TrueAlarm Smoke Sensor Model #4098-9714), Remote Test Switch Model #2098-9806 and Sample Tube Kit Model #4098-9857.
Provide solid state, non-polarized, 24VDC, photoelectric type duct detector compatible with the Fire Alarm Control Panel that obtains its operating power from the supervisory current in the fire alarm detection loop.
Provide duct detectors that operate on the light scattering, photodiode principle. Provide an insect screen to minimize nuisance alarms. Provide duct detectors designed to ignore invisible particles or smoke densities that are below the factory set point. Provide duct detectors with sensor heads that are directly interchangeable with an ionization detector type. The 24VDC detector may be reset by actuating the Fire Alarm Control Panel reset switch.
Provide duct detectors with a mounting base with a twist-lock detecting head that is lockable. The locking feature must be field removable when not required. Provide contacts between the base and head of the bifurcated type utilizing spring type, self-wiping contacts. Interrupt the supervisory current of the fire alarm detection loop upon removal of the detector head and cause a trouble signal at the Fire Alarm Control Panel. Provide compatibility of the detector design with other normally open fire alarm detection loop devices (heat detectors, pull stations, etc.).
Provide duct detector housings capable of being alarmed by using a test switch.
Provide duct detector housings that provide access through the front cover for cleaning the detector sampling tubes.
Employ voltage and RF suppression techniques to minimize false alarms.
Install, where indicated on the plans, remote LED alarm indicators and key operated test stations. Locate test stations along foot traffic routes within the space in which the duct detector is located and mount where accessible without the use of a ladder.
7. Individual Adaptor Module (IAM) - Model #4090-9001
Use Individual Adaptor Modules for monitoring water flow switches, valve tamper switches and (if called for) non-addressable detectors.
Use IAMs for conventional 2-wire detection devices and/or contact devices monitored with Style D monitoring. These IAMs will monitor and communicate the device/zone's status (normal, alarm, trouble) to the Fire Alarm Control Panel.
Uniquely identify IAMs at the Fire Alarm Control Panel. Transmit device identification to the Fire Alarm Control Panel for processing according to the program instructions. Should an IAM become non-operational, tampered with, or removed, a discrete trouble signal, unique to the device, shall be transmitted to, and annunciated at, the Fire Alarm Control Panel.
Provide the capability of programming IAMs for their "address" location on the addressable device signaling line circuit. IAMs are to be compatible with addressable manual stations and addressable detectors on the same addressable circuit.

- Supervise the IAM for all trouble conditions. Indicate the type of trouble condition (open, short, device missing/failed) at the Fire Alarm Control Panel. Should an IAM fail, it will not hinder the operation of other system devices.
8. Relay Zone Adaptor Module (ZAM) – Model #4090-9008
 Use ZAMs for control of door hold opens, elevator functions during alarm conditions, control of air handling unit systems. Provide an addressable interface module for interfacing normally open, direct contact devices to an addressable signaling line circuit. Provide ZAMs capable of mounting in an outlet box (4 11/16" square x 2 1/8" deep). Include cover plates for ZAMs to allow surface or flush mounting. Provide 24VDC power to a ZAM from a separate two wire pair running from an appropriate power supply. Provide ZAMs with two, easily replaceable, 2 amp fuses, one on each common leg of the relay. Provide each module with Style Z version wiring supervision, looping the wiring back and connecting to the module to allow continual operation of the controlled devices even if the wiring sustains a single break. These ZAMs will communicate the supervised wiring status (normal, trouble) to the Fire Alarm Control Panel and will receive a command to transfer the relay from the Fire Alarm Control Panel. Uniquely identify ZAMs at the Fire Alarm Control Panel. Transmit device identification to the Fire Alarm Control Panel for processing according to the program instructions. Should the ZAM become non-operational, tampered with, or removed, transmit a discrete trouble signal, unique to the device, to the Fire Alarm Control Panel. Provide the capability to program the ZAMs for their "address" location on the addressable device signaling line circuit. Provide ZAMs compatible with addressable manual stations and addressable detectors on the same addressable circuit. Supervise the ZAM for all trouble conditions. Indicate at the Fire Alarm Control Panel the type of trouble condition (open, short, device missing/failed). Should a ZAM fail, it will not hinder the operation of other system devices.
 9. Visual Only - Multi candela units – Model #4906-9208 Wall Mount or 4906-9204 with a 4906-9207 Ceiling Mount (Requires Model #4009-9401 and Model #4009-9812)

 Provide, UL Listed, entirely sold state, visual only indicating appliances comprised of a synchronized xenon flashtube, compatible with ADA requirements for the occupancy in which the devices are installed. Synchronize all visuals to flash simultaneously. Transmit device identification to the Fire Alarm Control Panel for processing according to the program instructions. Should the Visual Only become non-operational, tampered with, or removed, transmit a discrete trouble signal, unique to the device, to the Fire Alarm Control Panel.
 10. Speaker Visual – Multi candela units – Model #4906-9251 with a 4906-9205 Wall Mount or 4906-9254 with a 4906-9207 Ceiling Mount (Requires Model #4009-9401 and Model #4009-9812) The preferred design is to provide a wall mounted multi candela unit Model #4906-9208 with a ceiling mounted speaker Model #4902-9721
 Provide polarized fire alarm speaker visuals that operate with 24VDC. Provide separate wire leads for in/out wiring for each leg of the associated signal (speaker or visual) circuit. Provide integral, synchronized, xenon strobe compatible with ADA requirements for the type of occupancy in which the speaker visual devices are installed. Provide 8000 peak candela power for each speaker visual and make adjustable from 1 to 3 flashes per second. Synchronize all visuals to flash simultaneously. Transmit device identification to the Fire Alarm Control Panel for processing according to the program instructions. Should the Speaker Visual become non-operational, tampered with, or removed, transmit a discrete trouble signal, unique to the device, to the Fire Alarm Control Panel.

D. FIRE ALARM EQUIPMENT ENCLOSURES

- Provide cabinet(s) of sufficient size to accommodate the following equipment:
- Fire Alarm Control Panels
 - Fire Alarm Control Panel associated electronic components
 - Remote Annunciators

Provide doors, with locks and MEDECO cylinders, for all cabinets. Provide cabinet covers (inside cabinet doors) for all cabinets.

For the Fire Alarm Control Panel cabinet, provide openings in the cabinet cover necessary to manipulate/access all the Fire Alarm Control Panel controls and a transparent door panel to allow freedom from tampering and full view of the various lights and controls. For all other cabinets, provide covered openings in the cabinet cover (for potential future modifications) and solid doors. Provide cabinet(s) of sufficient size to accommodate the following equipment:

- Fire Alarm Control Panels
- Fire Alarm Control Panel associated electronic components
- Remote Annunciators

Provide doors, with locks and MEDECO cylinders, for all cabinets. Provide cabinet covers (inside cabinet doors) for all cabinets.

For the Fire Alarm Control Panel cabinet, provide openings in the cabinet cover necessary to manipulate/access all the Fire Alarm Control Panel controls and a transparent door panel to allow freedom from tampering and full view of the various lights and controls. For all other cabinets, provide covered openings in the cabinet cover (for potential future modifications) and solid doors.

F. MASS NOTIFICATION EQUIPMENT

1. High Powered Speaker Array – 1600 (HPSS16)

Provide where indicated on the plans a ATI Model HPSS16 provides maximum coverage area and excellent voice clarity for outdoor mass notification applications where intelligibility of pre-recorded voice messages and live Public Address (PA) is important. The HPSS32 shall include 1600 watts of continuous audio output and is battery powered for reliable outdoor alerting even when AC power is lost as is often the case during an emergency. The HPSA shall come with all brackets and hardware suitable for pole mounting. The HPSS32 shall have the following features:

- Meets UFC and FEMA requirements
- Eight speaker horns and steel speaker mounting bracket
- Stainless steel enclosure with ventilated battery compartment, door intrusion switch and enclosure mounting bracket
- Unique, compact and highly efficient Class D amplifiers with 1600 watts of continuous audio output power integrated on a high-performance controller board
- Conformal-coated printed circuit boards for operating in harsh environments
- Simple and compact hardware design with field-proven reliability and very high MTBF (Mean Time Between Failures)
- Conventional VHF and UHF radio for receiving and transmitting FSK, DTMF and Two Tone Sequential (TTS) data signals
- Message encryption and security coding to prevent unauthorized system activations
- Built-in tone generator providing eight standard, pre-configured tones
- Automatic gain control for consistent output volume
- Local and remote testing and reporting including “silent” testing
- Temperature-compensated battery charger and power On/Off circuit breakers
- Very low standby power requirements and 30 minutes of continuous activation
- Antenna surge protection
- The HPSA shall be available with the following optional features
 - Solid-state flash memory capable of storing more than 250 audio files and 10 hours of playback time allowing for customized alert tones, voice messages and music playback specific to the application

- Solar panel upgrade to keep the batteries charged in applications where AC is not available or practical to install
 - Flexible and redundant communication methods including IP, Ethernet, twisted pair/telephone cable, fiber optic, cellular and satellite
 - Trunked radio upgrade
 - Local control panel upgrade with microphone, LCD display and controls for local activation and PA
 - Strobe lights and LED signs for visual alerting in areas with high ambient noise levels and recipients with hearing impairments
 - Alternative speaker types and configurations to provide optimal acoustic coverage
2. High Powered Speaker Array – 3200 (HPSS32)
- Provide where indicated on the plans a ATI Model HPSS32 provides maximum coverage area and excellent voice clarity for outdoor mass notification applications where intelligibility of pre-recorded voice messages and live Public Address (PA) is important. The HPSS32 shall include 3200 watts of continuous audio output and is battery powered for reliable outdoor alerting even when AC power is lost as is often the case during an emergency. The HPSA shall come with all brackets and hardware suitable for pole mounting. The HPSS32 shall have the following features:
- Meets UFC and FEMA requirements
 - Eight speaker horns and steel speaker mounting bracket
 - Stainless steel enclosure with ventilated battery compartment, door intrusion switch and enclosure mounting bracket
 - Unique, compact and highly efficient Class D amplifiers with 1600 watts of continuous audio output power integrated on a high-performance controller board
 - Conformal-coated printed circuit boards for operating in harsh environments
 - Simple and compact hardware design with field-proven reliability and very high MTBF (Mean Time Between Failures)
 - Conventional VHF and UHF radio for receiving and transmitting FSK, DTMF and Two Tone Sequential (TTS) data signals
 - Message encryption and security coding to prevent unauthorized system activations
 - Built-in tone generator providing eight standard, pre-configured tones
 - Automatic gain control for consistent output volume
 - Local and remote testing and reporting including “silent” testing
 - Temperature-compensated battery charger and power On/Off circuit breakers
 - Very low standby power requirements and 30 minutes of continuous activation
 - Antenna surge protection
 - The HPSA shall be available with the following optional features
 - Solid-state flash memory capable of storing more than 250 audio files and 10 hours of playback time allowing for customized alert tones, voice messages and music playback specific to the application
 - Solar panel upgrade to keep the batteries charged in applications where AC is not available or practical to install
 - Flexible and redundant communication methods including IP, Ethernet, twisted pair/telephone cable, fiber optic, cellular and satellite

- Trunked radio upgrade
 - Local control panel upgrade with microphone, LCD display and controls for local activation and PA
 - Strobe lights and LED signs for visual alerting in areas with high ambient noise levels and recipients with hearing impairments
 - Alternative speaker types and configurations to provide optimal acoustic coverage
3. Remote Terminal Unit (RTU)
- Provide where indicated on the plans a Remote Terminal Unit ATI Model RTU adjacent to the Fire Alarm Control Panel. The RTU can interface a wide variety of inputs and outputs to the ATI control system. The fire alarm interface to the RTU shall report all alarms and troubles. The RTU shall use a NEMA-4/3R enclosure cabinet.
 - The RTU Controller Board equipped with eight 10 Amp/250VAC relay outputs, eight optically isolated inputs, four configurable analog data inputs, a tone generator and local push buttons for testing. The RTU shall communicate to the Central Control Unit (CCU) via Conventional VHF or UHF radio or via standard Ethernet (IP). The RTU shall contain a temperature compensated battery charger, door intrusion switch and Power on/power off circuit breakers.
 - The radio shall be standard VHF and UHF radio receives and transmits FSK data signals. The RTU shall have very low standby power requirements, message encryption and security coding to prevent unauthorized system activations. Circuit boards in the RTU shall be conformal coated for operation in harsh environments.
 - The RTU shall be capable of a Flexible, redundant communication options including IP Ethernet, twisted pair/phone line, cellular, satellite as well as UHF/VHF Radio. The RTU shall also have an optional local panel upgrade with microphone, LCD display, an optional solar power option and strobe lights or LED sign output option. RTU can also be upgraded to a stainless steel NEMA-4/3R enclosure
4. Text Messaging Appliance (Message Board)
- Provide where indicated on the plans a Text Messaging Appliance (Message Board) Simplex Model 4907-0001. Each unit shall be connected to the building fire alarm system and to the campus Ethernet. Message Board must be delivered to UofA FM Fire Safety for pre-programming and configuration prior to installation.

PART 3 - EXECUTION

3.1 INSTALLATION

- A. Provide and install the system in accordance with the plans and specifications, all applicable codes and the manufacturer's recommendations.
- B. Install all wiring in strict compliance with all the provisions of NEC - Article 760 A and C, Power-Limited Fire Protective Signaling Circuits or if required may be reclassified as non-power limited and wired in accordance with NEC-Article 760 A and B. Upon completion, the contractor shall so certify in writing to the Owner. Adhere to all other applicable NEC wiring methods.
- C. Install wiring that is approved by the fire alarm equipment manufacturer.
- D. Install Class A (Style 6 Signaling Line Circuit as defined by NFPA-72) communications.
- E. Install all Class A circuits such that the outgoing and return conductors, exiting from and returning to the control unit respectively, are routed separately. Do not run the outgoing and return circuit conductors in the same cable assembly (multiconductor cable), enclosure or raceway. Separate the field outgoing and return wiring by at least 6 feet or by 1-hour fire rated construction. Outgoing and return wiring does not have to be separated where:
 - 1. The circuit is installed underground

2. The circuit encased in 2 hour fire resistive construction
 3. The circuit makes a single drop to an individual device within 10 feet of the loop
Exceptions to the 6 foot/1-hour fire rated construction separation of outgoing and returning conductors will be considered by the Owner in unique device location circumstances. Request exceptions to this requirement in writing to the Owner.
- F. Individually configure circuits on site to provide either alarm/trouble operation, alarm only, trouble only, current limited alarm, no alarm, normally closed device monitoring, a non-latching circuit or a alarm verification circuit, to accommodate and facilitate job site changes.
- G. Provide separate circuits for the audible and visual portions of all alarm indicating appliances.
- H. Arrange wiring of the circuits for strobe devices such that adjacent strobe devices are on separate circuits. Limit the number of strobe devices on any one circuit to 12 devices.
- I. Provide a manufacturer's authorized representative on-site for supervision of the installation.
- J. Install all devices and fire alarm equipment in accordance with the current NEC, the manufacturer's recommendations, NFPA 72, the plans, these specifications and the requirements outlined below. Notify the Owner if the plans indicate (or field conditions necessitate) locating/positioning any devices contrary to the manufacturer's recommendations, NFPA 72, or the requirements outlined below.
1. Locate smoke detectors as follows:
No closer than 3 feet from any air supply diffuser.
No farther than 15 feet from a wall or end of a corridor.
No farther than 30 feet between detectors.
 2. Locate manual pull stations such that the operable portion of the pull station (the center of the handle) located at 48" above the finished floor level.
 3. Locate visual only devices such that the device is 80 inches above the finished floor level OR 6" below the finished ceiling level, whichever is lower. Measure height above/below the floor/ceiling to the center of the device.
 4. Locate audio/visual devices such that the device is 80 inches above the finished floor level or 6" below the finished ceiling level, whichever is lower. Measure height above floor/below ceiling to the center of the visual component of the device.
 5. Locate test switches for duct smoke detectors such that the device is adjacent to a traveled access aisle/path near the air handler served by the test switch and positioned not more than 48" above the finished floor level. Measure height above the floor to the center of the switch.
 6. Locate Fire Alarm equipment enclosures such that the center of the display portion of the panel is 60" above the finished floor.
 7. Locate Fire Alarm message boards in such a way that a building occupant in a common area, (hallway, classroom, large meeting room, or similar space,) shall be no more than 100' line of sight from a message board.
- K. Elevator Interface with Fire Alarm System – to facilitate elevator recall, install smoke detectors at each elevator lobby, in the elevator equipment room, and at the top of the elevator shaft as indicated on the plans. This interface shall be provided regardless of the existing elevator operation. Program the Fire Alarm Control Panel to use these devices to perform the elevator recall function as outlined in Section 1.3.K.2 of these specifications.
Connect the fire alarm system to the elevator controls for elevator recall with ZAMs. Pull three wires (a common, a normally open, and a normally closed) from each elevator recall ZAM into the elevator controls cabinet. If elevator equipment does not facilitate the actual recall function all preparations and installations shall be made to accommodate these functions.
Where there are sprinkler heads in the elevator shaft, elevator pit, or elevator equipment room, install heat detectors, as indicated on the plans, within 2 feet (measured horizontally) of each sprinkler head. For these specific locations, provide heat detectors with a lower temperature rating and higher sensitivity (response time index), as compared to the sprinkler heads.
Provide an auxiliary alarm relay to interlock with the elevator power shut-off/shunt trip unit.
Provide an IAM and a Fire Alarm Auxiliary Relay to monitor the presence of shunt trip power.

Provide a shunt trip circuit breaker on the elevator equipment power circuit in the elevator equipment room. Extend the interlock conductors from the Fire Alarm Control Panel to the new shunt trip circuit breaker.

Provide control ZAM or Relay IAM to activate car fire alarm light if an alarm has been detected in the machine room or hoistway.

- L. Air Handler Motor Control Interface with Fire Alarm System
1. Provide a single pole, double throw relay switch for loads up to 120VAC for each air handling unit's motor control center that is equipped with duct smoke detection. Provide a separate 24 VDC output relay with 10A, 120VAC rated contacts with a 7A in-line fuse for control of each type of equipment shown. Provide power to this relay from the 24VDC power to the relay ZAM. Control this relay from the type 2 control ZAM contacts. Locate relays in a separate electrical outlet box (4 11/16" square x 2 1/8" deep) adjacent to the air handling unit motor control center. Route circuits from motor controls and duct detector relay box. Route ONLY 24VDC into the control ZAM box.
- M. Door Holder Control
1. Provide ZAMs for the fire alarm system's control of door holders.
 2. Provide a double pole, double throw relay capable of switching for loads up to 120VAC for each door holder circuit.
 3. Locate relay in a separate electrical box (4" square standard) adjacent to the ZAM box. Route 120VAC circuits from door holders and 24VDC circuit from ZAM into relay box. Orient relay so 120VAC circuit does not cross the 24VDC circuit inside the relay box. Route ONLY 24VDC into the ZAM box.
 4. Provide power to relay from the 24VDC power to the ZAM. Provide the output relay with 10A, 120VAC rated contacts with a 7 Amp in-line fuse for control of each door holder circuit. Control this relay from the ZAM contacts.
 5. Provide door holder control ZAM with Style Z version wiring supervision, looping the wiring back and connecting to the module to allow continual operation of the controlled devices even if the wiring sustains a single break. Communicate the ZAM's supervised wiring status (normal, trouble) to the Fire Alarm Control Panel and receive commands to transfer the relay from the Fire Alarm Control Panel.
- N. After the completion of the installation, clean all dirt and debris from the inside and the outside of the fire alarm equipment.

3.3 ACCEPTANCE INSPECTION AND TESTING

- A. Perform testing during hours approved by the Owner.
- B. Fully test every function, every device, and the operation of the completed fire alarm system in the presence of the Owner and the equipment manufacturer's representative.
- C. During the testing outlined above, the Owner will direct the contractor and equipment manufacturer's representative as to the Custom Labels to be programmed into the fire alarm system for identification of each device. This process will involve the contractor inspecting and activating each device in the presence of the owner's representative, the manufacturer's representative noting the Custom Label designation as directed by the Owner and programming this information into the Fire Alarm Control Panel.
- D. Certify, in writing, to the Owner that the fire alarm system is fully functional at the completion of the test. In addition to this written certification, provide the owner with a print out and a computer disc of the Fire Alarm Control Panel's programming documentation.
- E. Fully test the system in the presence of, and as directed by, the Authority Having Jurisdiction representative and the Owner. Should the system fail this test, make all repairs and upon receipt by the Owner of notification in writing by the contractor of compliance with the required repairs.

3.4 LABELING/MARKING

- A. Paint red all fire alarm pull and junction boxes and associated covers that will be located in concealed spaces **prior** to their installation.
- B. Identify the fire alarm system wiring on the pull or junction box cover by printing "FA" with an indelible felt tip pen. Print the identification neatly and legibly.
- C. Maintain wiring color code as indicated in 2.2.A and Section 16127 of these specifications throughout the installation.

DIVISION 16 ELECTRICAL**PROJECT NO.**

- D. Maintain label tags on all wiring at junction points, per these specifications and 1996 NEC Article 760-10.
- E. Mark, with an indelible felt tip pen, the panel box and circuit number on the junction and pull boxes covers of all non-fire alarm wiring connected to the fire alarm system. Print the number of the panel box and circuit number neatly and legibly.
- F. Mark each fire alarm device with its IDNET circuit and device number as indicated below with an indelible felt tip pen. Print the IDNET circuit and device number neatly and legibly.
 - Pull stations - On the inside of the pull station face plate, visible when pull station opened with key.
 - ZAMs) - On cover of ZAM box. (Include ZAM function, i.e., shunt trip, air handler shut down, etc.
 - IAMs - On the IAM body.
 - Duct Detectors - On the duct detector housing
- G. Mark each fire alarm smoke detector and heat detector with its IDNET circuit and device number as indicated below with Kroy (or equal) self-adhesive tape with minimum 3/16" high black text. Cover identification text on smoke and heat detectors with Highsmith (or equal) pre-cut, 4 mil, non-glare, self-adhesive vinyl label protectors (item number L97-16140). Locate identification tape on detector base.

LEGEND

- ① PRIMARY FLOOR ZAM MOUNTED ON 4 11/16" BOX. SEE "CONTROL ZAM FOR PRI RECALL" DETAIL ON DRAWING E8.04.
- ② PRIMARY FLOOR ZAM MOUNTED ON 4 11/16" BOX. SEE "CONTROL ZAM FOR ALT RECALL" DETAIL ON DRAWING E8.05.
- ③ 4 11/16" BOX FOR SHUNT TRIP ZAM/ RELAY IAM AND MONITOR IAM.
- ④ FIRE ALARM SHUNT TRIP ZAM/ RELAY IAM TO ACTIVATE CONTROL RELAY.
- ⑤ FIRE ALARM IAM TO MONITOR POWER STATUS.
- ⑥ 4 11/16" BOX FOR CONTROL AND MONITOR RELAY.
- ⑦ CONTROL RELAY TO ACTIVATE SHUNT TRIP DEVICE IN ELEVATOR CIRCUIT BREAKER AND LOCAL STATUS LIGHT. SEE "CONTROL ZAM FOR ELEVATOR SHUNT" DETAIL ON DRAWING E8.05.
- ⑧ MONITOR RELAY TO REPORT TO FIRE ALARM SYSTEM. SEE "CONTROL ZAM FOR ELEVATOR SHUNT" DETAIL ON DRAWING E8.05.
- ⑨ SHUNT TRIP CIRCUIT BREAKER. SEE E5.02 FOR SIZE.
- ⑩ HAT FLASH ZAM/ RELAY IAM MOUNTED ON 4 11/16" SEE "CONTROL ZAM FOR ELEVATOR SHUNT" DETAIL ON E8.05.
- ⑪ GENERATOR RUN ZAM/ RELAY IAM ON 4 11/16" SEE "CONTROL ZAM FOR ELEVATOR SHUNT" DETAIL ON DRAWING E8.05.

